

# Reversible mounted ploughs

## Vari Flex CX CX Plus EX

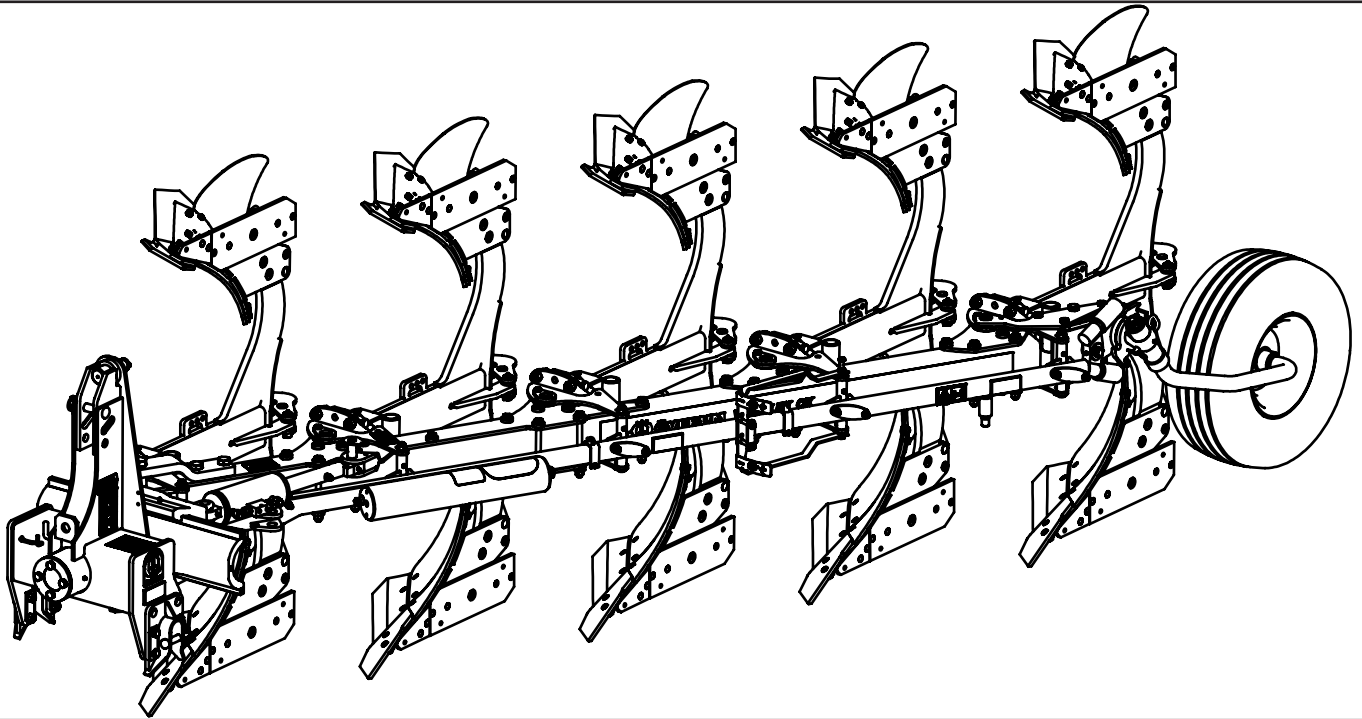

Instruction Manual  
"Original Instructions"

EN

Edition:  
170329

---

EF-overensstemmelseserklæring/ EG-Konformitätserklärung/ EC Declaration of Conformity/ Déclaration CE de conformité/ Dichiarazione CE di conformita/ EG Verklaring van Overeenstemming/ EG-försäkran om överensstämmelse/ EY-vaatimustenmukaisuusvakuutus/ Declaración de conformidad CE/ Deklaracija Zgodności WE./ Декларация за съответствие EO/ EK Megfelelőségi Nyilatkozat /ES Prohlášení o shodě/ EB Atitikties deklaracija/ ES prehlásenie o zhode/ Declarația de conformitate CE/ Vastavuse Deklaratsioon EÜ /ES Izjava o skladnosti/ Δήλωση πιστότητας EK/ Declaração de fidelidade CE/ Dikjarazzjoni ta' Konformità tal-KE/ EK Atbilstības deklarācija/

Fabrikant/ Hersteller/ Manufacturer/ Fabricant/ Produttore/ Fabrikant/ Fabrikant/ Valmistaja/ Fabricante/ Producent/ Производител/ Gyártó/ Výrobce/ Gamintojas/ Výrobca/ Producător/ Tootja/ Proizvajalec/ Κατασκευαστής/ Fabricante/ Fabbrikant/ Ražotājs

CNH INDUSTRIAL SWEDEN AB.  
Bruksgatan 4, 59096 Överum, SWEDEN

Repræsenteret af Antoon Vermeulen, Leon Claeystraat 3A, B8210 Zedelgem (Belgien), som også har tilladelse til at indsamle teknisk dokumentation / vertreten durch Antoon Vermeulen, Leon Claeystraat 3A, B8210 Zedelgem (Belgium), der auch autorisiert ist, die technische Akte zu erarbeiten / represented by Antoon Vermeulen, Leon Claeystraat 3A, B8210 Zedelgem (Belgium), who is also authorised to compile the Technical File / Réprésentés par Antoon Vermeulen, Leon Claeystraat 3A, B8210 Zedelgem (Belgique), également autorisé à constituer le dossier technique / rappresentati da Antoon Vermeulen, Leon Claeystraat 3A, B8210 Zedelgem (Belgio), autorizzato a compilare il File tecnico / vertegenwoordigd door Antoon Vermeulen, Leon Claeystraat 3A, B8210 Zedelgem (Belgium), die tevens is gemachtigd om het Technisch Bestand samen te stellen / representerade av Antoon Vermeulen, Leon Claeystraat 3A, B8210 Zedelgem (Belgien), som också har behörighet att sammanställa den tekniska dokumentationen / edustajamme Antoon Vermeulenin, osoite Leon Claeystraat 3A, B8210 Zedelgem (Belgium) välityksellä, jolla on myös oikeus laatia tekninen tiedosto / representados por Antoon Vermeulen, Leon Claeystraat 3A, B8210 Zedelgem (Bélgica), quien además está autorizado para recopilar el documento técnico / której przedstawicielem jest Antoon Vermeulen, Leon Claeystraat 3A, B8210 Zedelgem (Belgia), który jest również upoważniony do sporządzenia dokumentacji technicznej / представлявани от Антоон Вермюлен, Leon Claeystraat 3A, B8210 Zedelgem (Белгия), с упълномощение също да състави Техническото досие / akiket képvisel: Antoon Vermeulen, Leon Claeystraat 3A, B8210 Zedelgem (Belgium), aki szintén jogosult a műszaki dokumentumok összeállítására / v zastoupení Antoon Vermeulen, Leon Claeystraat 3A, B8210 Zedelgem (Belgium), s autorizací k tvorbě technického souboru / atstovaujami Antoon Vermeulen, Leon Claeystraat 3A, B8210 Zedelgem (Belgija), taip pat turintis teisę sudaryti technines bylas / v zastúpení Antoonom Vermeulenom, Leon Claeystraat 3A, B8210 Zedelgem (Belgicko), ktorý je oprávnený zostavovať technickú dokumentáciu / reprezentați de Antoon Vermeulen, Leon Claeystraat 3A, B8210 Zedelgem (Belgia), care este, de asemenea, autorizat să compileze dosarul tehnic / esindajatega Antoon Vermeulen, Leon Claeystraat 3A, B8210 Zedelgem (Belgia), kellel on samuti luba tehnilise faili koostamiseks / ki nas zastopa Antoon Vermeulen, Leon Claeystraat 3A, B8210 Zedelgem (Belgija), ki je pooblaščen tudi za sestavo tehnične dokumentacije / εκπροσωπούμενοι από τον Antoon Vermeulen, Leon Claeystraat 3A, B8210 Zedelgem (Βέλγιο), με εξουσιοδότηση και για τη σύνταξη του Τεχνικού φακέλου / representados por Antoon Vermeulen, Leon Claeystraat 3A, B8210 Zedelgem (Bélgica), que também tem autorização para compilar o Ficheiro Técnico / irraprezentata minn Antoon Vermeulen

Leon Claeyssstraat 3a, B8210 Zedelgem (Belgju), min huwa wkoll awtorizzat li tiġbor l-Fajl Tekniku / Antoon Vermeulen, Leon Claeyssstraat 3A, B8210, Zedelgem (Belgium), pārstāvēti, kas ir pilnvarots arī sastādīt tehnisko reģistru

Erklærer hermed, at/ Erklären hiermit, daß/ Hereby declare that/ Déclare par la présente que/ Dichiaro che/ Verklaren hierbij dat/ Försäkrar härmed, att/ Vakuuttaa täten, että tuote/ Por el presente declara que/ Niniejszym deklaruje, że/ Декларирам, че/ Az alábbiakban kijelentem, hogy/ Tímto prohlašuje, že/ Deklaruoja, kad/ Týmto prehlasujeme, že/ Prin prezenta declar că/ Alljärgnevaga deklareerib, et/ Izjavljamo, da je/ Με το παρόν δηλώνω ότι/ Abaixo declara que / Jiddikjaraw li / Apstiprinu, ka

Maskine:	La máquina:	Masin:
Maschine:	Maszyna:	Stroj:
Machine:	Μαшина:	Η μηχανή:
Machine:	Gép:	Máquina:
La macchina:	Stroj:	Il-magna:
Machine:	Mašina:	Mašina:
Maskin:	Stroj:	
Laite:	Mašina:	



Type: Vari Flex CX, CX Plus, EX  
Designation: Tillage  
VIN: 300000-320000

- er i overensstemmelse med Maskindirektivets bestemmelser (Direktiv 2006/42/EF) og hvis relevant også bestemmelserne i EMC-direktivet 2014/30/EU.
- In übereinstimmung mit den Bestimmungen der Maschinen-Richtlinie 2006/42/EG und wenn erforderlich auch mit der EMC-Richtlinie 2014/30/EU hergestellt wurde.
- is in conformity with the provisions of the Machinery Directive 2006/42/EC and if relevant also the provisions of the EMC Directive 2014/30/EU.
- est conforme aux dispositions de la Directive relatives aux machines 2006/42/CE et également aux dispositions de la Directive sur la Directive EMC 2014/30/UE.
- é in conformita' con la Direttiva Macchine 2006/42/CE e, se pertinente, anche alla Direttiva alla Direttiva EMC 2014/30/UE.
- in overeenstemming is met de bepalingen van de Machine richtlijn 2006/42/EG en wanneer relevant ook met de bepalingen van de EMC richtlijn 2014/30/EU.
- är i överensstämmelse med Maskindirektivets bestämmelser (Direktiv 2006/42/EG) och om relevant också bestämmelserna i EMC-direktivet 2014/30/EU.
- täyttää Konedirektiivin (Direktiivi 2006/42/EY) määräykset ja oleellisilta osin myös EMC-direktiivin 2014/30/EU.
- es conforme a la Directiva de Maquinaria 2006/42/CE y, si aplica, es conforme también a la Directiva EMC 2014/30/EU.
- pozostaje w zgodzie z warunkami Dyrektywy Maszynowej 2006/42/WE i jeżeli ma to zastosowanie również z warunkami Dyrektywy dot. kompatybilności elektro magnetycznej EMC 2014/30/UE.
- отговаря на изискванията на Директивата за Машините 2006/42/ЕО и ако има приложение на изискванията на Директивата за електромагнитна съвместимост 2014/30/ЕС.
- Megfelel a 2006/42/EK Gépi Eszközökre vonatkozó előírásoknak és amennyiben felhasználásra kerül, a 2014/30/EU Elektromágneses kompatibilitás Irányelv feltételeinek.
- odpovídá základním požadavkům Strojní směrnice 2006/42/ES a jestliže to její uplatnění vyžaduje i s podmínkami Směrnice 2014/30/EU týkající se elektromagnetické compatibility.
- atitinka Mašinų direktyvos Nr. 2006/42/EB ir, jeigu taikoma, Elektromagnetinio suderinamumo direktyvos Nr. 2014/30/ES reikalavimus.

- 
- je v súlade s podmienkami Smernice 2006/42/ES o strojných zariadeniach a pokiaľ si to jeho uplatnenie vyžaduje aj s podmienkami Smernice 2014/30/EÚ o elektromagnetickej kompatibilite.
  - îndeplineşte prevederilor Directivei de Maşini 2006/42/CE şi dac  este utilizat  de asemenea cu prevederile Directivei referitoare la compatibilitatea electro-magnetic  EMC 2014/30/UE.
  - on vastavuses Masinate Direktiivi tingimustega 2006/42/E  ning sammuti juhul, kui on tegemist sammuti on vastavuses Elektromagnetilise kokkusobivuse Direktiivitingimustega EMC 2014/30/EL.
  - z dolo ili Direktive o strojih 2006/42/ES ter,  e je to relevantno, tudi z dolo ili EMC Direktive 2014/30/EU.
  - παραµένει σύµφωνη µε τους  ρους της Οδηγίας περ  Μηχαν ν 2006/42/EK και σε περίπτωση που αυτ  εφαρµόζεται και µε τους  ρους της Οδηγίας περ  ηλεκτροµαγνητικής συµβατότητας (ΗΜΣ) 2014/30/EE.
  - Est  de acordo com exig ncias das Directivas das Maquinarias 2006/42/CE e no caso em que tiver igualmente aplica  o com as exig ncias das Directivas referentes a compatibilidade electromagn tica EMC 2014/30/UE.
  - tikkonforma mad-dispo izzjonijiet tad-Direttiva dwar il-Makkinarju 2006/42/KE u jekk rilevanti wkoll mad-dispo izzjonijiet tad d-Direttiva EMC 2014/30/EU.
  - atbilst ma inu direkt vai 2006/42/EK, k  ar  nepiecie am bas gad jum  elektromagn tisk s sader bas direkt vai EMC 2014/30/ES.

Zedelgem  
Antoon Vermeulen

---

# FOREWORD

## DEAR CUSTOMER!

Please read these instructions carefully. If you follow the instructions given, you can expect good results along with a good economic return from your choice of plough.

If carefully operated, adjusted and maintained, the plough will meet all reasonable demands made on it and will give you reliable service in years to come. Should you need further instructions, which are not included in this manual, or require the help of experienced service personnel, we advise you to contact one of our local representatives, which also will have spare parts in stock.

It has always been the ambition of Överum to constantly improve its products. Consequently, in the interest of product improvement, no specification is final or binding and we reserve the right to alter the design of new machine series and equipment without previous notice.



CNH Industrial Sweden AB  
Bruksgatan 4  
S-590 96 Överum  
Sweden

Tel.: +46 493 36100  
E-mail: [sales@overums-bruk.se](mailto:sales@overums-bruk.se)

---

# CONTENTS

FOREWORD .....	1
1. INTRODUCTION .....	3
Description of function .....	3
Identification of plough .....	4
Safety Regulations .....	5
2. TECHNICAL DESCRIPTION .....	9
Checking the tractor prior to ploughing .....	9
Preparation of the plough .....	11
Mounting the plough onto the tractor .....	11
Connection of hydraulics .....	12
Checking the plough .....	13
Turn-Over Mechanism .....	14
3. BASIC SETTINGS .....	15
Basic settings of the plough .....	15
Disc coulters .....	18
Adjustment / Setting of skimming devices .....	19
Troubleshooting - Ploughing .....	21
Adjustment of working width .....	22
Hydraulic diagram working width adjustment .....	23
Combi Wheel .....	24
4. STONE TRIP SYSTEM .....	27
Shear bolt protection .....	27
Hydraulic stone trip system .....	27
Adjustment of operating pressure .....	28
Checking the accumulator .....	29
5. DRIVING A REVERSIBLE PLOUGH .....	30
Useful operational points .....	31
6. MAINTENANCE .....	32
Replacement of wearing parts .....	32
Parallelism and G-measurement of the mouldboards .....	33
Tightening the bolts .....	34
Greasing of the beam hinge points .....	34
Tyre pressure .....	35
Winter storage .....	35
Lubrication chart .....	36
Changing the turn-over direction .....	38
7. USEFUL ADVICE .....	40
8. LIFTING POINTS .....	41
9. BASIC A-MEASUREMENTS .....	44
10. TECHNICAL DATA .....	45

# 1. INTRODUCTION

## DESCRIPTION OF FUNCTION

This plough is designed only for “Reversible Ploughing” by using right-hand and left-hand plough bodies alternately, and for transportation between the farm and different fields. H-ploughs that are equipped with a hydraulic stone trip system can be used in all types of soil. F-ploughs that are equipped with a shear bolt protection are to be used only in soils that are free of stones.

The turn-over mechanism is only to alter the right and left hand bodies between their working positions.

The plough is to be attached to the three-point linkage at the rear of the tractor, with the hydraulic systems connected to the appropriated hydraulic outlets.

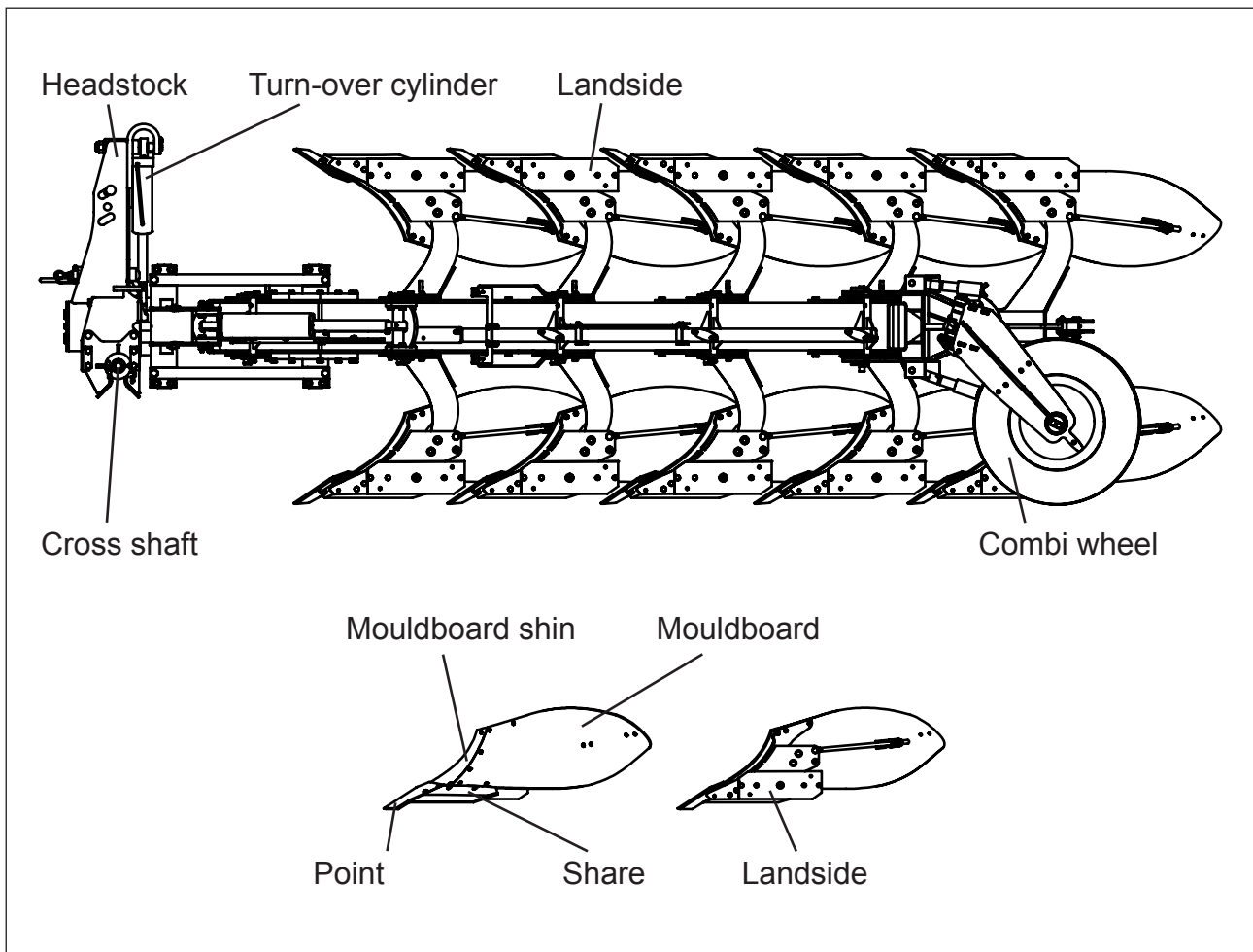

# IDENTIFICATION OF PLOUGH

## Type designation

VF CX        3975-5980 31075-41080  
 VF CX P     4975-5980 41075-51080  
 VF EX        5975-6975 41075-61080

Stone trip system    H = Hydraulic  
                               F = Fixt (shear bolt)

Beam height         75 or 80 cm

Plough body spacing    9=90 cm  
                                   10=100 cm

Number of plough body pairs

Machin type

Designation

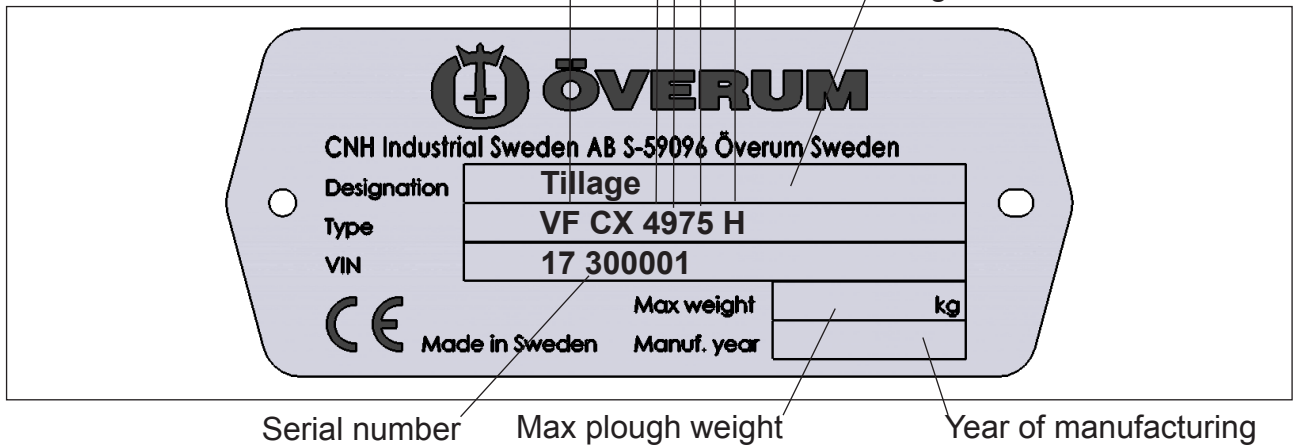

Complete the sign below with the Machine type and Serial number of Your plough.

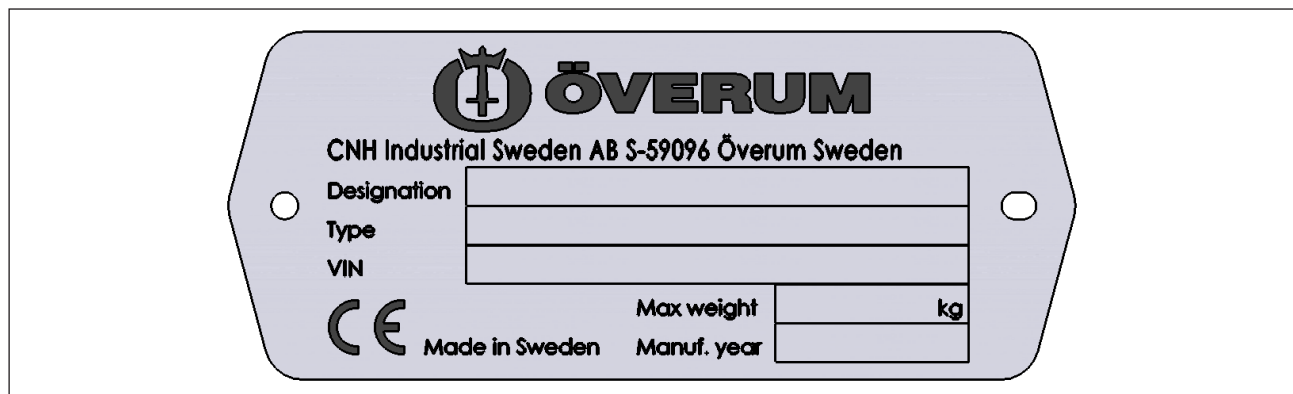



# SAFETY REGULATIONS

**READ THE INSTRUCTION MANUAL. SAFETY IS YOUR RESPONSIBILITY.**



**You should read the instruction manual before you change any settings or start using the plough. The plough is designed and manufactured with as many safety features as possible, but we cannot foresee all possible circumstances that can involve safety hazards with this machine.**

Your responsibilities as owner or operator are to ensure the safety of any personnel in connection with: the operation, transport, maintenance or storage of the machine. If you have questions not answered in this manual, please contact your dealer or distributor.

Be aware of your responsibilities. The most important safety device is a safety conscious operator, whose training and experience must include:

- Operator competence, the operator must be able to carry out a correct and complete adjustment of settings and to ensure safe and reliable operation. Training in safety issues is to be reviewed or repeated annually.
- Being aware of their environment to the extent that unforeseen safety issues that may arise are dealt with to ensure the safety of all personnel (including operators, maintenance personnel and bystanders).



**This symbol means: SAFETY ALERT!**

**The safety decals in the instruction manual are used to highlight given instructions that involve safety of all personnel. Failure to comply with a given instruction could result in severe injury or death.**

**SAFETY ALERT decals** Note! The decals on the machine can differ from the decals in this instruction manual.

## GENERAL SAFETY INSTRUCTIONS

### **Keep a safe distance**

Do not stand under, on or close to the plough when it is in operation or when it is connected to the tractor.

### **Support the Plough**

Do not stand under, on or close to the plough if the plough is not properly supported.

### **Lower the plough**

The plough should be lowered to the ground when standing still.

### **Front ballast weights**

The front of the tractor should be fitted with balance weights as required to maintain optimal traction and directional stability. Ensure that at least 20% of the tractor's weight is carried by the front wheels.

## 1. INTRODUCTION

---

### **Be alert**

Ensure that no person is on, underneath or in the hazardous area of the plough during transport, ploughing or when maneuvering the plough. Never work under a lifted plough!

### **Use the support leg**

Always use the support leg when the plough is parked. Park the plough on level firm surface.

### **Do not allow passengers**

Do not allow anyone to ride on the implement when it is being transported or while in operation.

## **SAFETY WHEN CONNECTING AND DISCONNECTING THE PLOUGH**

### **Risk for personal damage**

An unintentional manoeuvre with the tractor may cause serious injury. Always make sure that nobody is standing between the tractor and the machine during connection and disconnection.

Make sure that the plough is locked with sufficient locking pins. During operation, negative forces can occur that push one side of the cross shaft and the lower link of the quick coupling upwards. There is a risk that the hook can release. Therefore, the quick coupling on the lower links should be secured with a bolt.

Make sure the tractors gear is in neutral before starting the engine.

### **Make sure that there is no pressure in the hydraulic hoses**

Before the tractor engine has stopped, make sure that there is no pressure in the hydraulic hoses by activating the tractor spool valves to floating position.

### **Check the length of the hydraulic hoses**

Check the length of the hydraulic hoses when the plough is lowered to working position. Check that they are not too tense.

### **Check connection of hydraulic hoses**

Make sure that the hydraulic hoses are connected to the correct hydraulic outlets on the tractor. If connected incorrectly, the plough can move in an unforeseen way.

## **MAINTENANCE SAFETY**

### **Avoid contact with oil and grease**

To avoid oil and grease contact with your skin, wear protective gloves.

### **High oil pressure**

The plough must be mounted to the tractor!

Be careful when the plough is examined for oil leaks or damaged fittings. Hydraulic oil under pressure can penetrate the skin and cause serious damage. Always release the pressure in the hydraulic system prior to maintenance work on the hydraulic system and make sure that all components are correctly tightened before the system is set under pressure. Always wear gloves and eye protection.

Never tamper with the gas filling valve on the accumulator!

### **Do the maintenance regularly**

Do the maintenance work regularly as it is described in this manual, section 6 MAINTENANCE. Replace wearing parts as described. There is a risk of poor performance if the machine not is maintained properly.

### **Retighten all nuts and bolts**

Always remember to retighten all nuts and bolts after about 3 hours of use. Make sure that bolts and nuts are tight at all times. Tightening torques are shown in section 6 MAINTENANCE.

### **Use protection gloves**

Always use gloves when working with parts on the machine as they can have sharp edges.

## **TRANSPORT SAFETY**

### **Beware of the length of the plough**

The plough is long and does not completely follow the tractor in sharp turns. Avoid that the plough's rear end hits an obstacle. The tractors braking pedals must be locked together during transport driving.

### **The stabilizers of the lower links**

The stabilizers of the lower links should be locked when the plough is in transport position, so that the plough is fixed sideways.

### **Comply with the relevant traffic regulations**

The operators have to observe relevant statutory or other national regulations dealing with road safety and labor safety issues.

### **Drive safe, max 25km/h**

Be a safe and courteous driver, yield to oncoming traffic. In all situations, do not exceed 25 km/h.

## WARNING DECALS

### Explanations



4165 99101 00 Read the manual!

Carefully read the instructions and observe all safety instructions before you connect the machine to the tractor.



4165 98301 00 Warning hazardous area!

It is not allowed to be within the hazardous area, on, under or close to the machine during transport driving, operation or when the plough is reversed. Never work under a lifted plough. Always make sure that nobody is standing between the tractor and the machine.



4165 98300 00 High oil pressure!

Be careful when oil leaks or damaged fittings are examined. Hydraulic oil under pressure can be dangerous. Always release the pressure in the hydraulic system prior to maintenance work on the hydraulic system and make sure that all components are correct tightened before the system is set under pressure. Always wear gloves and eye protection.



4165 99102 00 Support leg

Do not stand close to the plough if not properly supported. When parking the plough always use the support leg.



4165 34375 00 Transport lock

The plough can swing down against the vertical stop when the transport lock is released. Be alert!



4165 25073 00 Warning! Risk of crushing

Risk of crushing injuries. Be careful!



## 2. TECHNICAL DESCRIPTION

---

The following track widths are recommended: 1200 - 1500 mm  
Ideal track width = 3 x the furrow width + 100-150 mm  
(Example: 16" furrow width 3 x 400 + 125 = 1325 mm)

When ploughing with "wide tyres" the outside walls of the front and the rear tyres should be parallel. The furrow widener knives should be mounted on the last pair of plough bodies.

**Note:** Large mounted ploughs can affect the stability of the tractor.

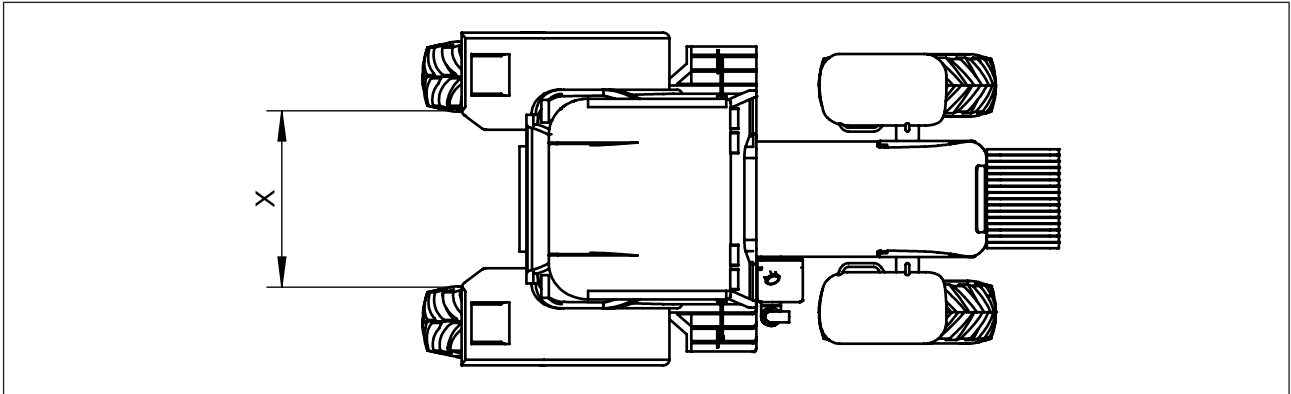

### TYRE PRESSURE

Both tyre life and optimum traction are achieved by using the correct tyre pressure. Over-inflation will increase wheel slip. Make sure that both rear tyres are inflated to the same pressure.

### FRONT BALLAST WEIGHTS

The front of the tractor should be fitted with balance weights as required to maintain optimal traction and directional stability.

### LIGHTING

The tractor must be equipped with working lights when plowing in the dark.

### PREPARATION OF THE PLOUGH

Check that the quick-couplings on the hydraulic hoses are the same type as the quick-couplings on the tractor, if required fit the correct quick-couplings to suit your tractor.

Cross shafts Cat. 3 with  $\varnothing$  36 mm cross-shaft pins or bigger must be used on all 5-furrow ploughs.

Cat.	B	C	VF CX	VF CXP FV EX
2	825	$\varnothing$ 28	X	
2L	965	$\varnothing$ 28	X	
3	965	$\varnothing$ 36	X	X
4	965	$\varnothing$ 50,8 mm (2 Inc)		X

The cross shaft must always be mounted **centrally** in the headstock and locked with the lock collars.

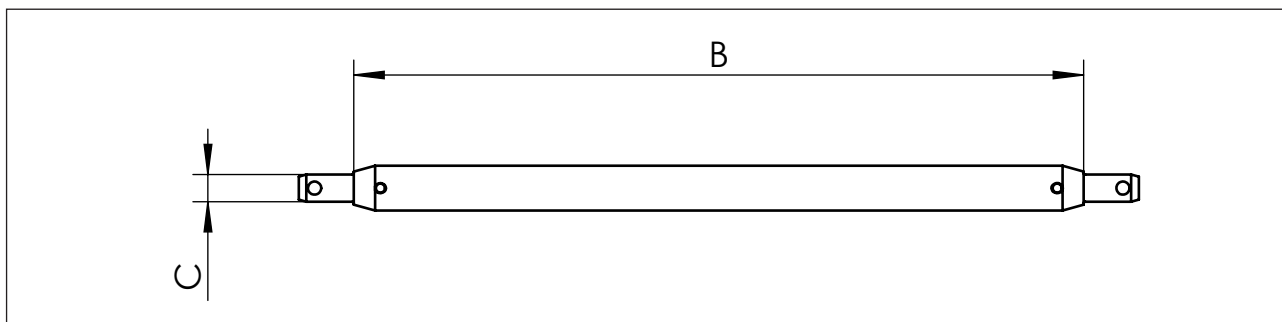

### MOUNTING THE PLOUGH ONTO THE TRACTOR

Ensure that the tractor's lower links (ball joints) are at the same height (measure and if necessary adjust the lifting links) and that the lower links can be lowered approximately 20 cm below the cross shaft. The lower link ball joints and the top link ball joint must be of the same category as the cross shaft and the top link pin. **LOCK THE LOWER LINKS AND THE TOP LINK WITH SUFFICIENT LOCKING PINS.**

Make sure stabilisers of the lower links are correctly adjusted.

#### Ploughing position:

The plough should be able to move sideways (not being tensioned into place).

#### Transport position:

The plough should not be able to swing out and collide with the tractor wheels or fenders.

## 2. TECHNICAL DESCRIPTION

### Cross shaft height

The cross shaft can be mounted in two positions. This is done by altering the height of the cross shaft's quick-coupler mounting brackets after that the bolts **A** have been removed.

Lower position when higher lift height is required.

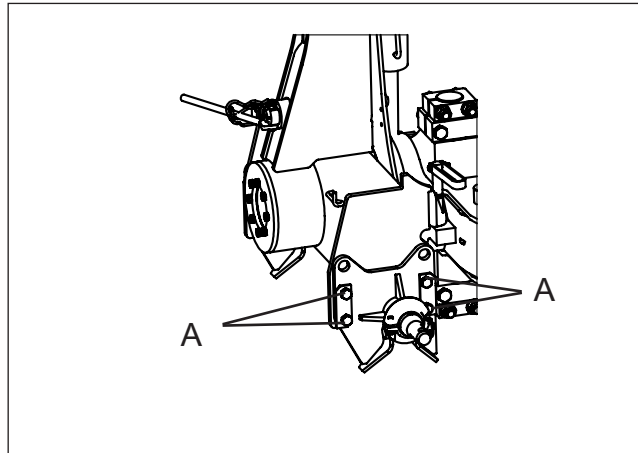

### Quick hitching of the plough (all plough types)

- Remove the cross shaft by removing the locking pins.
- Mount the cross shaft onto the tractor's lower links.
- Reverse the tractor so that the cross shaft is placed straight under the quick coupling bracket on the headstock.
- Mount the top link.
- Lift the tractor's lower links until the cross shaft is in place in the quick coupler brackets.
- Lock the cross shaft by remounting the locking pins.

## CONNECTION OF HYDRAULICS

Connect the hoses to the tractor's double-acting hydraulic outlets. It is advisable to arrange the connections so that the hydraulic output control lever can be moved in the most convenient direction.

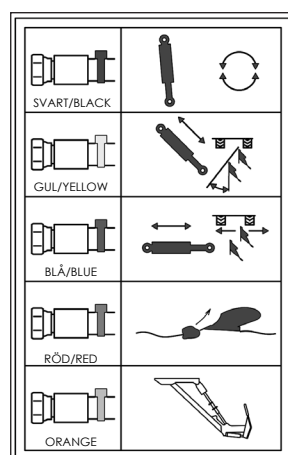
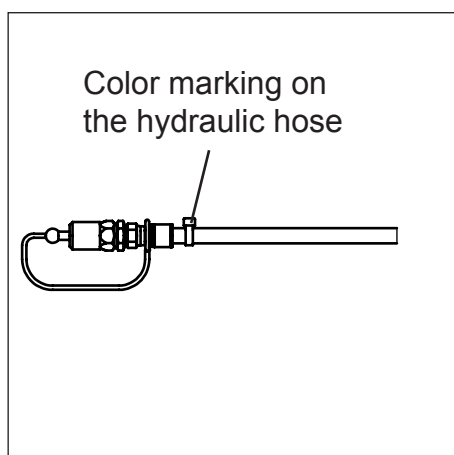

### ID of hydraulic hoses

Black	Turn-over cylinder
Yellow	Adjustment of working width
Blue	Separate adjustment of front furrow
Red	Stone release system
Orange	Furrow press arm



### CHECKING THE PLOUGH

- Check the tightness of all bolts and nuts
- Grease all lubrication points
- Check the tyre pressure and adjust as necessary. See chapter 6. Maintenance, Tyre pressure.
- Mouldboards: In order to make it easy starting up a new plough, the frontside of the mouldboards, skim coulters and coverboards are protected with wax. The wax do not have to be removed before the plough is used for the first time.
- Check the disc coulter, the skim coulter settings and adjust so that the settings are identical.
- Raise the plough and fold up the support leg, check the turn-over mechanism.
- **Always remember to re-tighten all nuts and bolts after about 3 hours of use, apart from that you should make sure that bolts and nuts are tight at all times.**

### STONE TRIP SYSTEM

Check the working pressure by reading the pressure gauge. For suitable working pressure see section: 4. STONE TRIP SYSTEM, ADJUSTMENT OF OPERATING PRESSURE.

# TURN-OVER MECHANISM

## FUNCTION

The turn-over mechanism consists of one or two double acting hydraulic cylinders that are connected to one double acting hydraulic outlet on the tractor. If the plough is equipped with a cylinder for alignment the plough will first be aligned behind the tractor and then the turn-over action will begin. Three and four furrow ploughs are not equipped with alignment cylinder as standard.

When the turn-over action is activated, the double-acting cylinder pull the plough up to the middle position, the oil flow in the turn-over cylinder will then automatically be changed and push the plough into the other sides ploughing position.

**Hold the hydraulic output control lever in the same position during the entire turn-over cycle until it is completed.** When the turn-over action is completed the lock valves will automatically lock the plough in ploughing position.

The lever is to be activated in the same direction every time. In order to achieve the correct rollover speed, maintain a higher idle during the entire rollover.

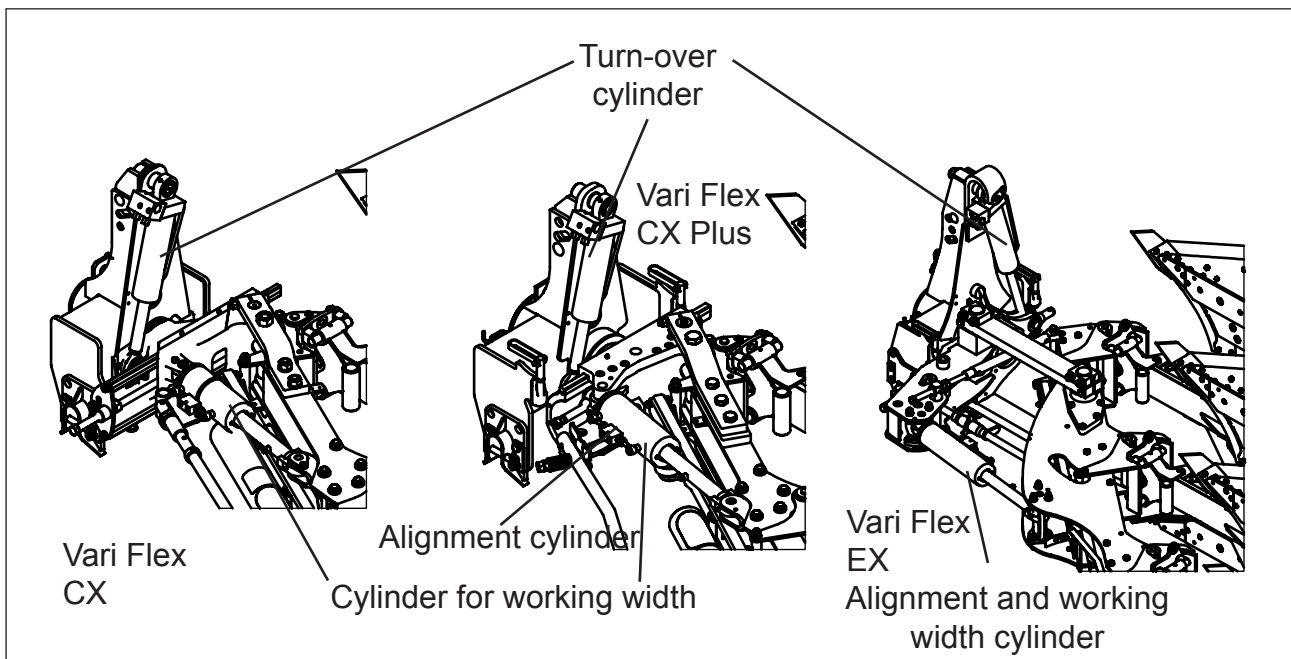

## 3. BASIC SETTINGS

### BASIC SETTINGS OF THE PLOUGH

The basic setting can be started when the desired ploughing depth has been reached and when the tractor wheels (right or left hand pair) are running in a furrow with the same depth.

#### 1. VERTICAL ADJUSTMENT

The tractor lower links must be at the same height to give the correct vertical angle. The vertical setting can be checked by observing the plough from the rear. The beams should be at right angles (90 °) to the ground.

The vertical adjustment of the right-hand bodies is altered with the adjustment screw **A** on the left side of the plough, and vice-versa.

ADJUSTING: Lift the plough out of the ground, turn the plough over, adjust the stop screw, turn the plough back over, lower the plough and continue ploughing.

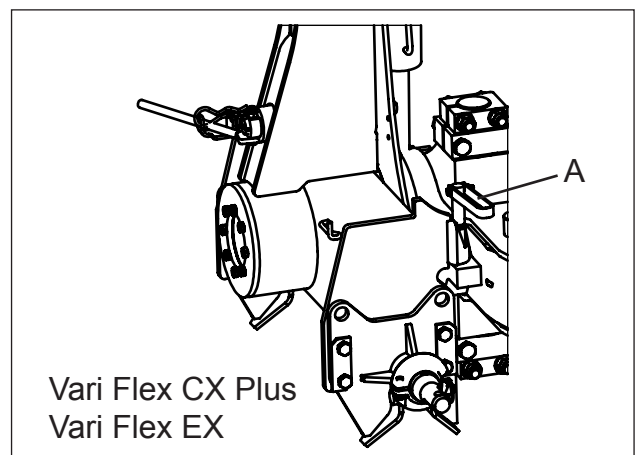
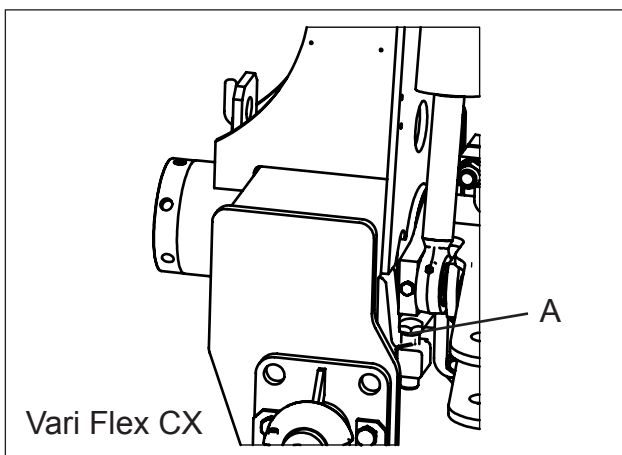
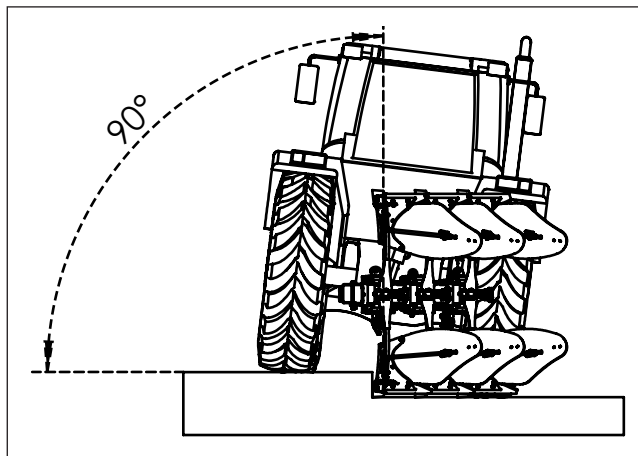

## 3. BASIC SETTINGS

### 2. HORIZONTAL ADJUSTMENT

Mount the top link so that it is 5 - 10 cm lower on the tractor than on the plough when in working position. The top link can be mounted in three positions on the plough. The slotted centre hole can be used on tractors equipped with lower link sensing hydraulic system, and it should be used with large ploughs. For ploughing in hard conditions using ploughs with 2-4 plough body pairs, the top link should be attached in a fixed position to prevent the rear plough body from working too shallow.

Adjust the length of the top link so that the depth of ploughing is the same for the first and last bodies. The frame will now run parallel to the ground.

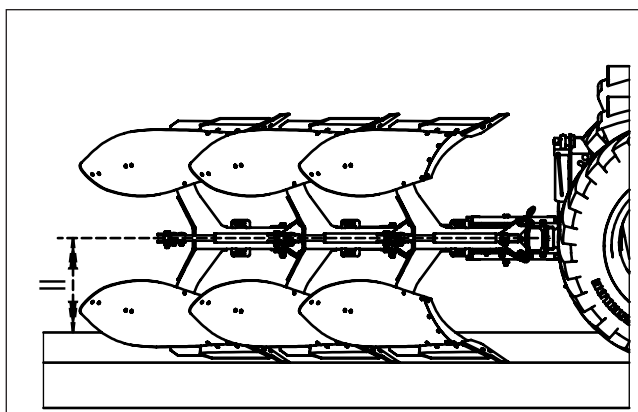

### 3. FIRST FURROW WIDTH AND PULL LINE

The cross shaft must be centrally mounted in the headstock.  
NOTE! Make sure that the tractor's lower links are not tensioned.

To avoid unnecessary wear of the plough and to minimise the draft the aim should be to set the plough to run as freely as possible straight behind the tractor.

Adjust the **A**-turnbuckle so the turn-over axle runs inline with the tractors centre line.  
Shortening of **A**- Adjustment screw = the plough moves towards the ploughed ground.  
Lengthening of **A**-Adjustment screw = the plough moves away from the ploughed ground.

Drive forwards and check the result. If the first furrow is not cutting the right width, adjust with the front furrow adjustment screw **B**.

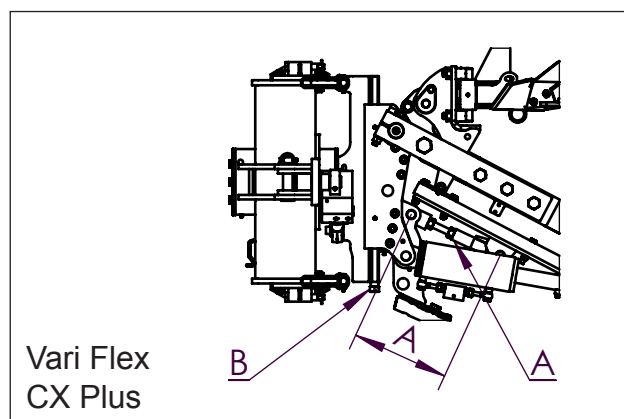
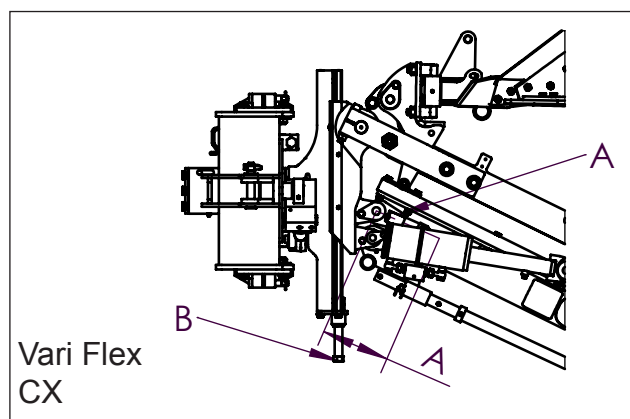

### 3. BASIC SETTINGS

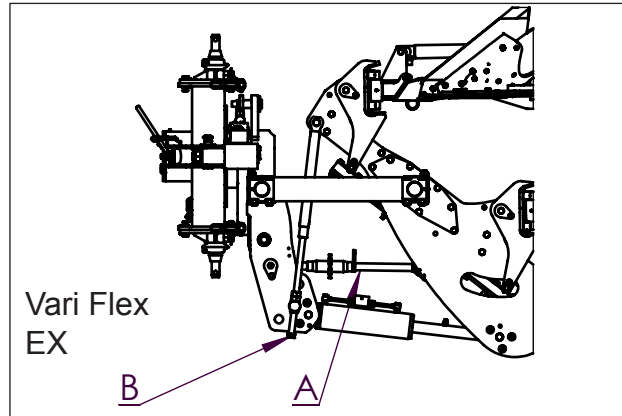

#### 4. PLOUGHING DEPTH

The optimum traction of the tractor is improved by using the hydraulic draught control to determine the ploughing depth. When soil conditions varies, the operator will be required to use the depth control lever to ensure that the ploughing is maintained at a uniform depth.

The use of a depth wheel on the plough will give uniform ploughing depth. The best method is to use a combination of depth wheel and draught control, which gives a good weight transfer in hard soils and allows the depth wheel to limit the ploughing depth in light soils.

The set screws **A** are used to set the individual depth for each side.

The wheel axle can be adjusted in different position, depending on ploughing depth **B**.

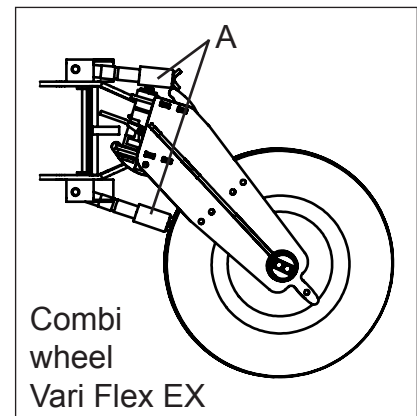
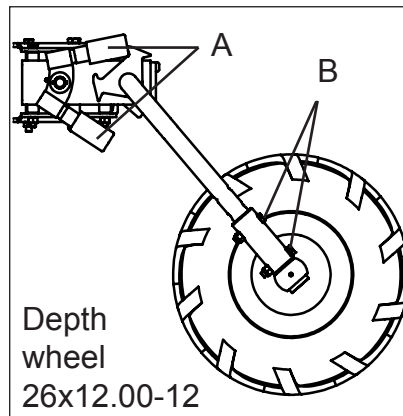
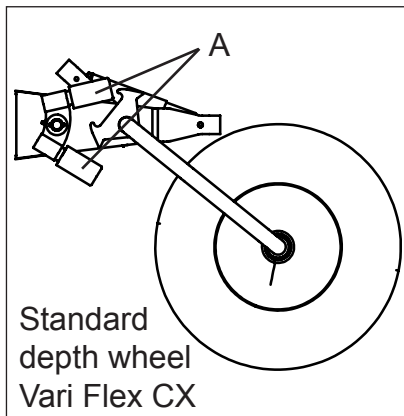

#### 5. VERTICAL ADJUSTMENT, OTHER SIDE

Vertical adjustment for the other side of the plough is done as per item 1.



**Make sure that no one is in close proximity of the plough when turn-over action is carried out. Never attempt to adjust any of the settings while the plough is in use.**

## DISC COULTERS

The purpose of the disc coulters is to make a vertical cut, separating the furrow slices. There are two types of disc coulters, fixed and spring loaded. When ploughing in stony or very heavy soils, the spring-loaded type of disc coulters should be used. This is to protect the coulters and to ensure that they do not act like a support wheel, carrying the plough, which would prevent it from maintaining a correct ploughing depth.

### Side adjustment of disc coulters

The coulters should be set to produce a clean cut. Under normal conditions, the cut should be made 10 - 20 mm outside the landside, depending on type and condition of soil. The left and right hand coulters are set individually by loosening the nut on bracket **A** and turning the coulters shank sideways.

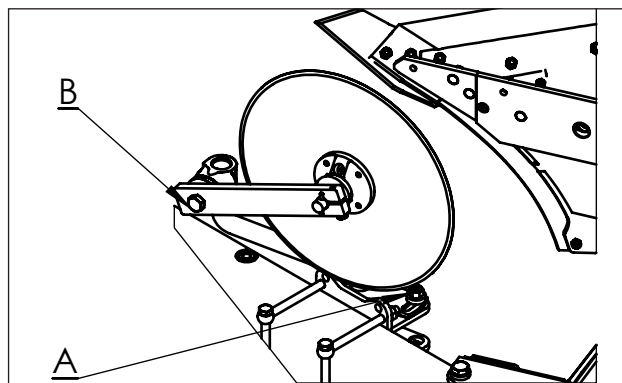
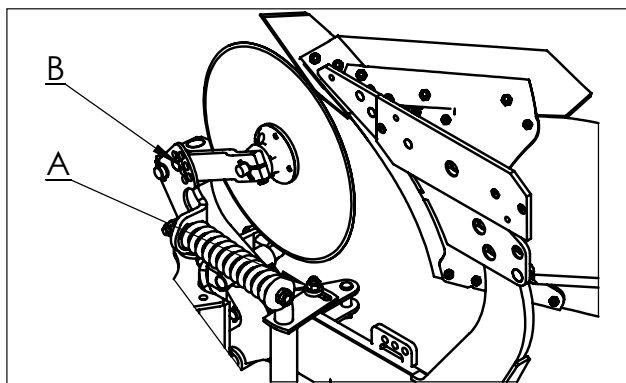
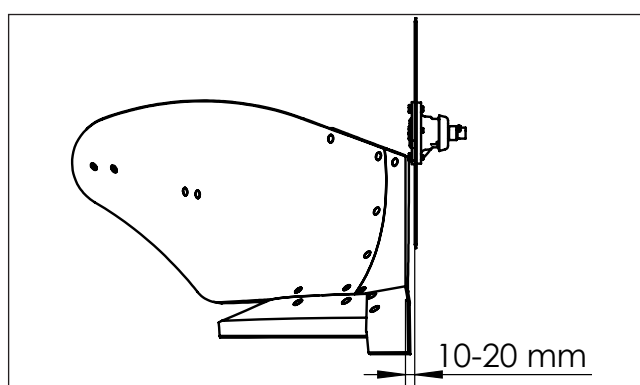

### Depth adjustment of disc coulters

To maintain a favourable cutting angle towards the surface, the disc coulters should never be set deeper in the ground than  $\frac{1}{3}$  of their diameter.

Depth adjustment is carried out by fitting the coulters arm to different positions, **B**. This applies for both fixed and spring loaded disc coulters.

Make sure that all disc coulters on the plough are set to the same depth and are on an equal distance from the landsides on both left and right hand sides.



**ATTENTION!** Be alert, there is always a risk for injuries while adjusting disc coulters and skimmers.

## ADJUSTMENT / SETTING OF SKIMMING DEVICES

The basic purpose of the skimming devices is to cut off and turn down a corner of the surface layer with crop residues and weeds so that these are well buried. Properly used skimming devices give the best mechanical weed control. Three different types of skimming devices are available for this purpose. All skimmers are equipped with shear bolt protection (Part no. 4165 20376 00)

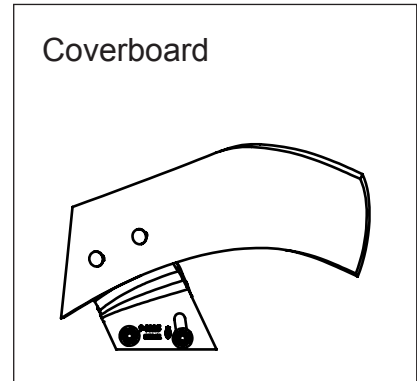
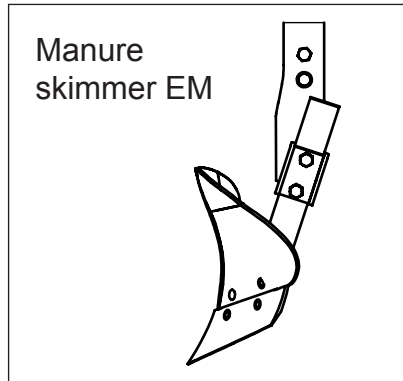
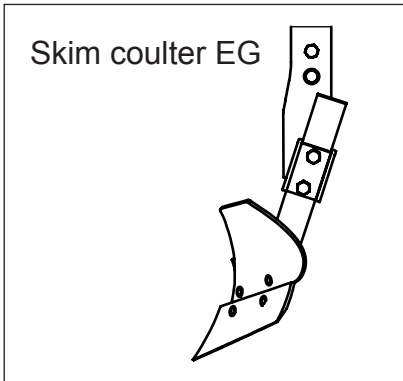

### Skim coulter EG

Skim coulter EG is used to advantage when good weed control is important and when ploughing grasslands. It works well in firmer soils, which produces a continuous furrow slice. The depth should not be set deeper than that a corner of the furrow slice is cut off and turned down. (Maximum 50 mm at the point).

When disc coulters are not mounted, the point of the skim coulter should be set to run about 10 - 20 mm outside the landside. When disc coulters are mounted, the skim coulters should run beside the disc coulters, with the points about 10 mm away from the disc.

### Manure skimmer EM

Recommended for deeper skimming and heavy trash. The convex mouldboard allows the trash to go on both sides of the skim shank. Works well without disc coulter.

The point of the manure skimmer should be set to cut approximately 10 - 20 mm outside the landside.

### Coverboard

The coverboard does not affect the diagonal clearance of the plough. As a result, it can be used to advantage in loose soils and where considerable quantities of straw are present, but not in sticky soils.

The operation of the coverboard is dependent on the depth and speed of ploughing. The front of the coverboard should always be in contact with the mouldboard shin, whereas the outer section can be adjusted vertically to suit the ploughing depth.



**NOTE: The coverboard should only cut off a small corner of the furrow slice.**

#### BASIC SETTING OF SKIMMERS (for 20 cm plough depth)

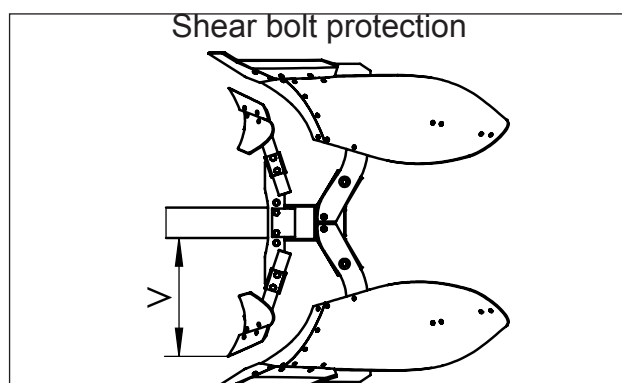
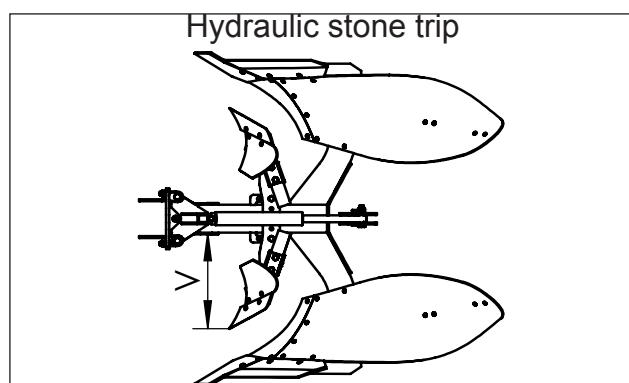

#### Hydraulic stone trip system

The mounting position of the skimmer bracket on the beam is the same if the plough is equipped with fin coulters or disc coulters.

The skimmer bracket is mounted in the rear hole as standard.

The distance **V** is measured between the beam and the skimmer share point and should be adjusted as follows:

Under beam clearance 75 cm     $V = 540$   
Under beam clearance 80 cm     $V = 620$   
(Valid for all types of skimmers EG and EM)

#### Shear bolt protection

The skimmer mounting brackets are to be mounted onto the beam housings.

The distance **V** is measured between the main frame and the skimmer share point and should be adjusted as follows:

**Vari Flex CX - Vari Flex CX Plus ploughs**  
Under beam clearance 75 cm     $V = 530$   
Under beam clearance 80 cm     $V = 580$   
(Valid for all types of skimmers EG and EM)

#### Vari Flex EX ploughs

Under beam clearance 75 cm     $V = 505$   
Under beam clearance 80 cm     $V = 555$   
(Valid for all types of skimmers EG and EM)

The skimmer share points should be set to cut approximately 10-20 mm outside the fin coulters or landsides if disc coulters are mounted

When the skimmers are adjusted all the skimmer share points should be in a straight line.



#### ATTENTION!

Be alert, there is always a risk for injuries when adjusting disc coulters and skimmers.



## TROUBLESHOOTING - PLOUGHING

The following common faults produce poor ploughing results, giving higher running costs and causing unnecessary wear on both the tractor and plough.

Problem	Reason	Checklist
Tractor pulls to one side and must be steered to counteract this	Plough incorrectly adjusted	Correct the plough adjustments, see basic settings: Check front and rear track widths. Check that the tractor's stabilisers are not tensioned.
Front end of tractor tends to lift	The front is too light. NOTE: The tractor must never be allowed to run on the back wheels (rear up)	Fit front weights or fill front tires with fluid
The first plough body cuts different furrow widths in left and right hand ploughing	The cross-shaft is not mounted centrally	Move the cross-shaft to the centre
	Incorrect vertical adjustment	Adjust the vertical adjustment
	Tractor lower links are unequal in length	Loosen the cross-shaft and adjust the plough until right and left-hand sides are equally wide
Uneven ploughing result left and right hand sides	Vertical adjustment faulty.	Adjust vertical adjustment, both sides.
	Different operating angles on right and left-hand mouldboards	Adjust the mouldboard operating angles so that the G measurement is equal on both sides, then adjust the parallelism
First furrow slice too high or low	Incorrect basic setting	Adjust as per basic settings: Front furrow width,
The furrows are stepped	Incorrect basic setting	Adjust as per basic settings: Horizontal and vertical settings
Furrow slices remain standing or are not fully turned	Skimming devices set too low	Adjust the skimmer's to reduce skimming action.
	Soil resistance causes plough to trip	Increase the working pressure
	Plough leans excessively toward unploughed side	Adjust the vertical setting.
	Furrow width too narrow in relation to depth	Increase the furrow width
Furrow height alters within the same run	Lateral setting of disc coulters incorrect	Adjust the coulters
	Skim coulters set to different depths or have incorrect side adjustment	Adjust the skimmers

## ADJUSTMENT OF WORKING WIDTH

The Vari Flex CX and Vari Flex CX Plus plough is equipped with infinitely variable furrow width, 12"/ 300mm – 20"/ 500mm; a double acting hydraulic cylinder alters the furrow width.

The Vari Flex EX plough is equipped with infinitely variable furrow width 12"/ 300mm – 22"/ 550mm.



**Note!** The hydraulic system for adjustment of the working width (furrow width) is separated from the system for reversing of the plough. A separate double acting valve is used for adjustment of the working width with a hydraulic cylinder A.

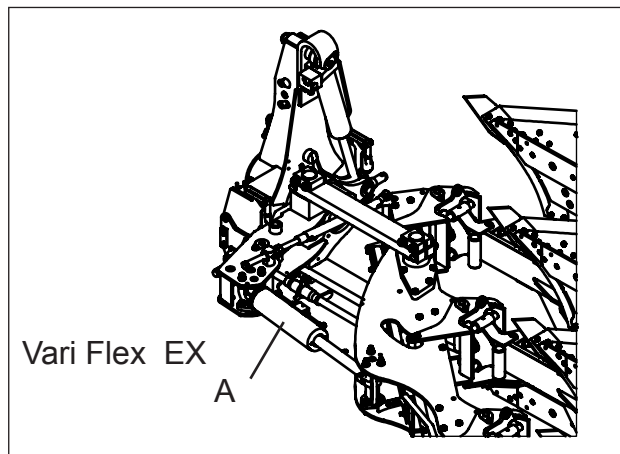
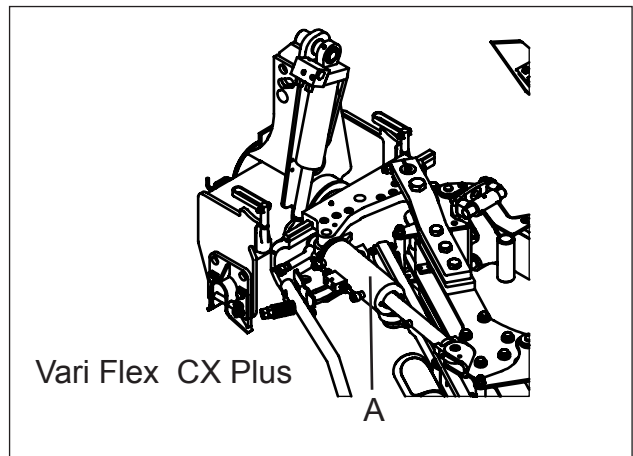
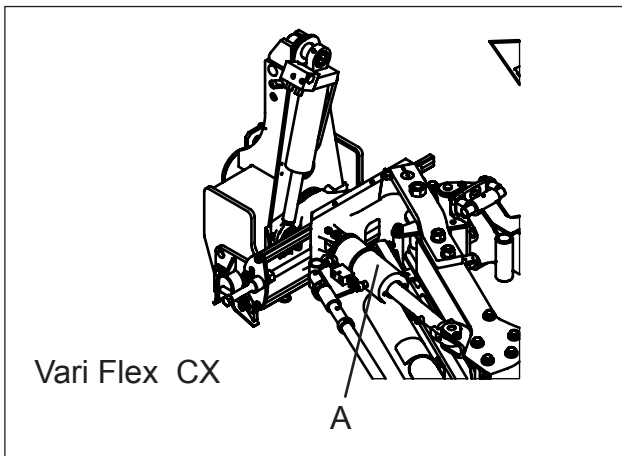

## HYDRAULIC DIAGRAM WORKING WIDTH ADJUSTMENT

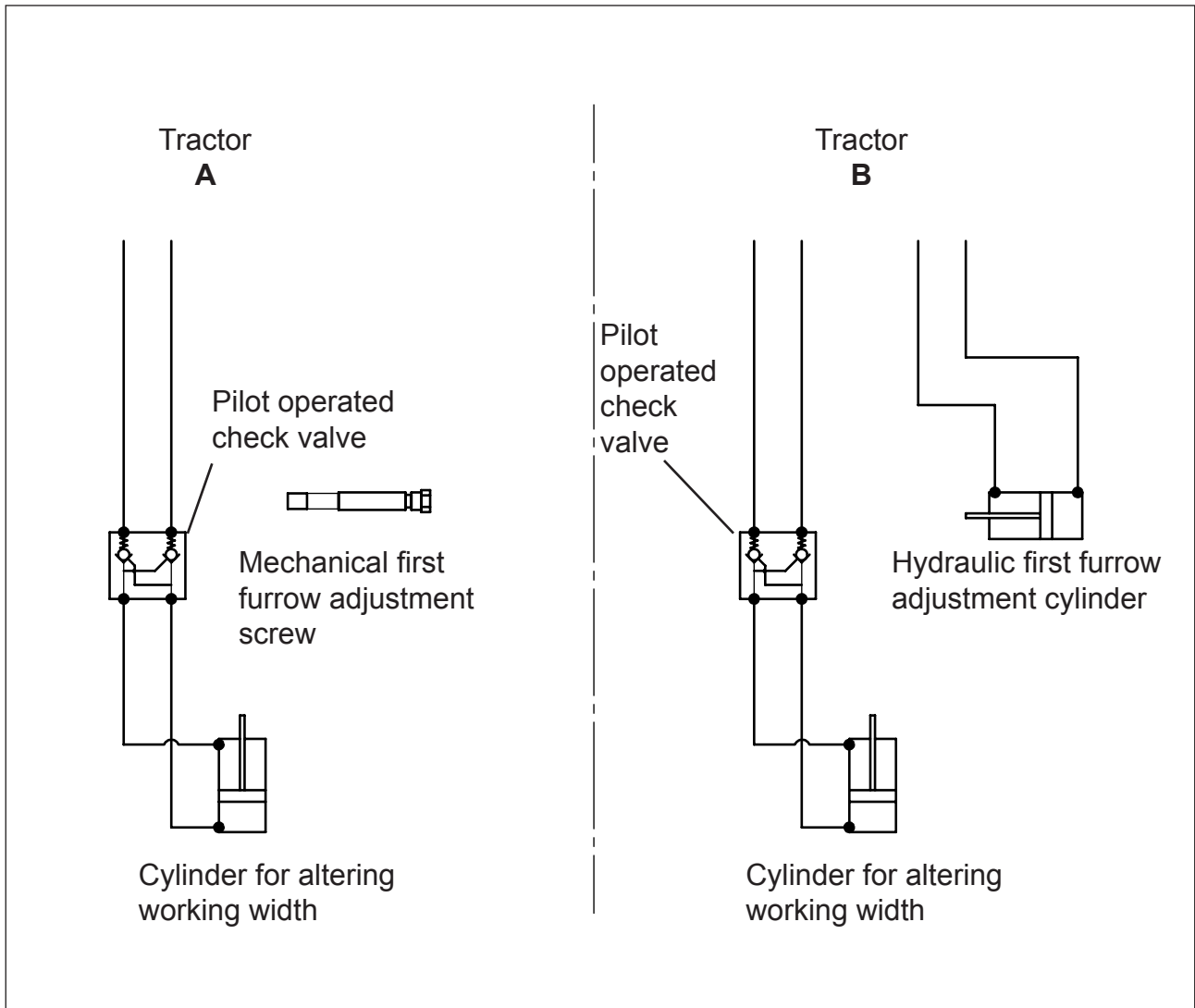

Version **A** requires one double acting hydraulic outlet from the tractor and version **B** two double acting outlets.

The front furrow is adjusted separate, in version **A** mechanical and **B** hydraulically.

## COMBI WHEEL

### COMBI WHEEL 10.0/80-12 VARI FLEX CX / VARI FLEX CX PLUS

The combination wheel is equipped with a spring tensioned friction brake.

#### Adjustment of the braking system

- Loosen the lock nuts **A**, so that the lock washer **B** is not in contact with the lock nuts.
- Adjust the friction brake with the large plough wrench.  
Clockwise = harder (more friction) .  
Counter clockwise = looser (less friction).  
Make a small adjustment and try the function, re-adjust if necessary.
- Make sure the lock washer **B** is approximately 2 - 3 mm from the lock plate **C** prior to tensioning the lock nuts **A**. This is to allow the lock washer to bend and lock around the centre shaft, which will prevent the lock plate from turning.

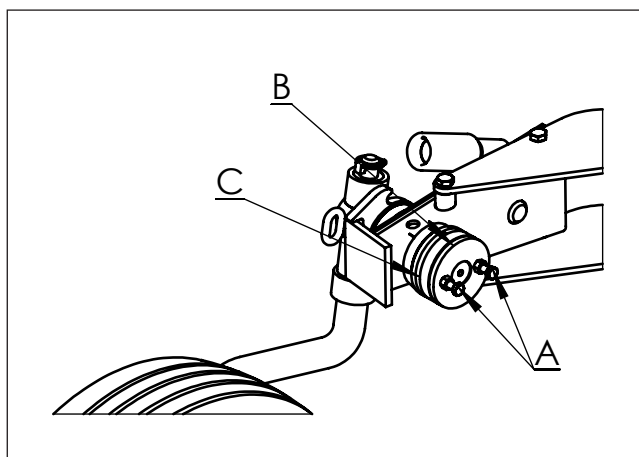

### TRANSPORT DRIVING WITH THE COMBI WHEEL IN BUTTERFLY POSITION

#### Transport position

- Lift the plough and remove the wheel with the wheel axle from the console.
- Place the wheel with the wheel axle into the bracket, which should be mounted onto the frame.
- Move the lever in the headstock to locking position.
- Activate the turn-over mechanism. The plough will now go up to middle position and remain locked in that position.
- Lower the front part of the plough so that the top link pin becomes situated in the centre of the long hole in the headstock, when the plough and the tractor stand on flat ground.
- The plough is now ready for transport driving and the wheel will act as a pivot wheel.

### 3. BASIC SETTINGS

#### Ploughing position

- Lift the plough
- Move the lever for the lock in the headstock to the unlocked position.
- Activate the turn-over mechanism so that the plough re-assumes ploughing position.
- Move the wheel with the wheel axle back to its position in the console.

#### COMBI WHEEL VARI FLEX EX

##### Function

When reversing the plough the wheel turns over backwards. A progressive braking system that can be adjusted protects the wheel. The wheel can easily be set to transport position. The ploughing depth is adjusted with the two set screws, see section 3: Basic settings, Ploughing depth.

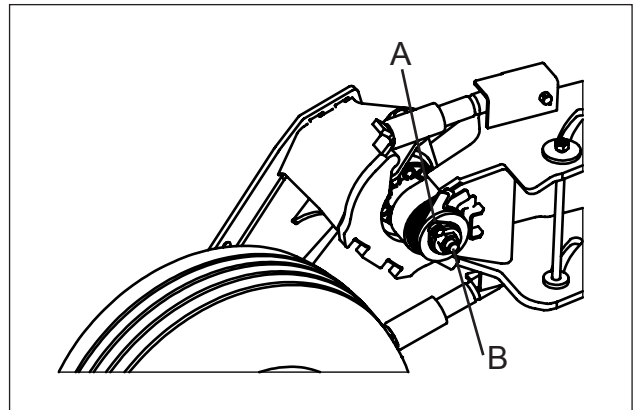
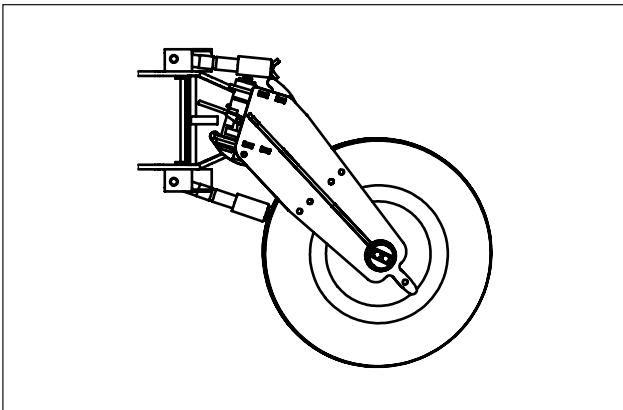

Adjustment: Remove the bolt and the lock washer **A** adjust the braking force by tensioning or loosening nut **B**. After adjustment, mount the lock washer. Never grease the friction plates!

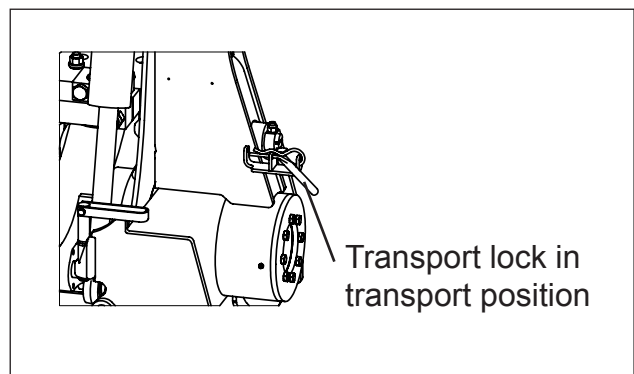
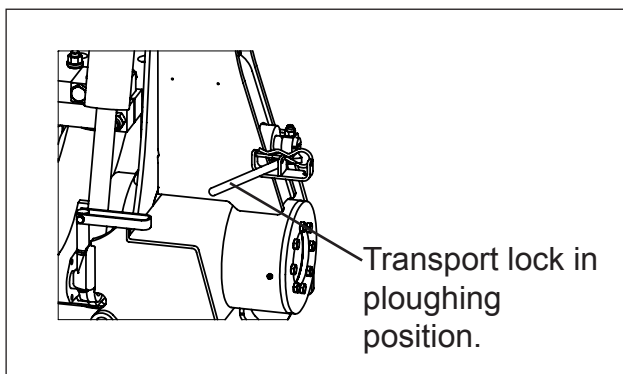

### 3. BASIC SETTINGS

---

#### **Transport driving**

- Reverse the plough so that the wheel is placed on left hand side (right hand plough bodies down).
- Press down the handle and swing the wheel out to transport position. Check that it is locked.
- Move the lever in the headstock to locking position.
- Activate the turn-over mechanism. The plough will now go up and lock in middle position.
- Lower the front part of the plough so that the top link pin becomes situated in the centre of the long hole in the headstock, when the plough and the tractor stand on level ground. The plough is now ready for transport.

#### **Back to ploughing position**

- Release the transport lock, push up the lever so that the locking axle is released through the slot.
- Lock the lever in the headstock to ploughing position.
- Reverse the plough so that the wheel is placed on left hand side (right hand plough bodies down).
- Lower the plough, press down the handle and swing the wheel out to ploughing position.

## 4. STONE TRIP SYSTEM

To protect the plough and tractor, all ploughs are equipped with a stone trip system.

### SHEAR BOLT PROTECTION

All (fixed beam) ploughs are protected by a shear bolt in each leg (part no. 4165 91399 00)

**NOTE:** Always ensures that the correct grade of bolt is used for replacement. Bolts of an inferior grade may distort without shearing, causing the plough body to get out of line.

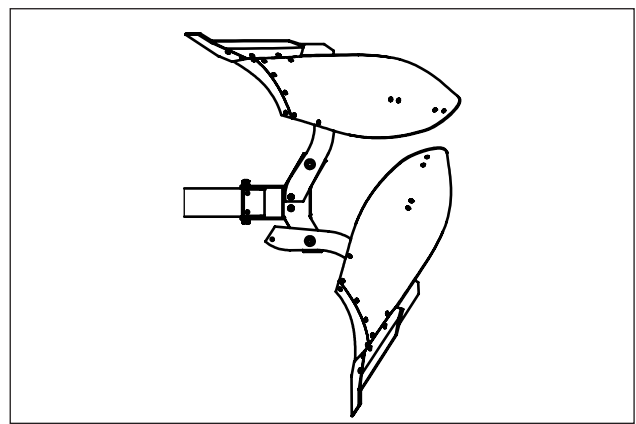
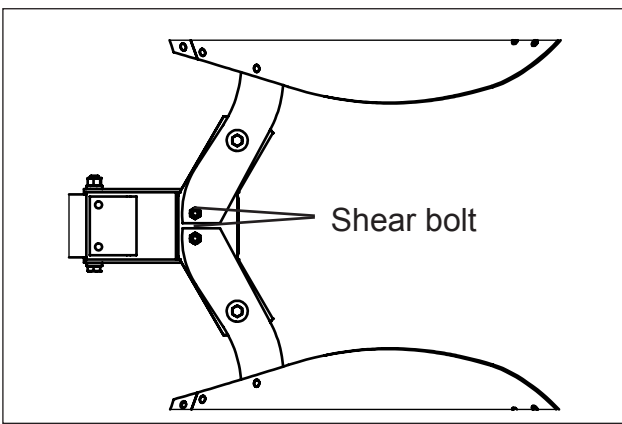

### HYDRAULIC STONE TRIP SYSTEM

The tripping mechanism consists of a trip cylinder for each pair of plough bodies. The cylinder is connected to a gas/oil accumulator. The accumulator is precharged with nitrogen gas (N<sub>2</sub>).

The trip cylinders, pressure hoses and the accumulator are pressurized with oil = working pressure as shown by the pressure gauge.

When ploughing, the pressure of the nitrogen gas acts as a spring inside the accumulator giving the plough bodies fully automatic and individual tripping and resetting actions.

The design of the trip system allows the plough bodies to move in all directions.

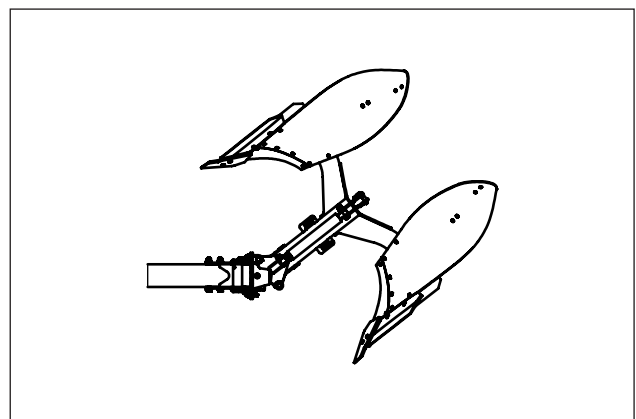
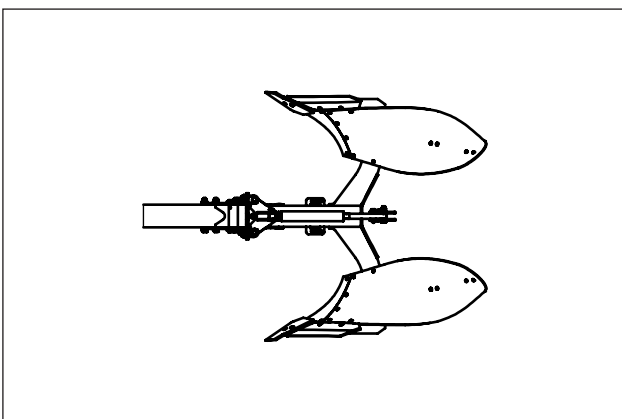

## 4. STONE TRIP SYSTEM

The precharge pressure in the accumulator is 9 MPa (90 bar).

The working pressure (oil pressure) is shown by the pressure gauge and should be at least 10% higher than the precharge gas pressure.

Working pressure should be between 10,5 - 14 MPa (105-140 bar).

**Rule:** The working pressure should not be adjusted higher than that the bodies keep their correct positions during ploughing and do not trip solely because of soil resistance.

### ADJUSTMENT OF OPERATING PRESSURE

Connect the filling hose (A) to a single-acting hydraulic outlet on the tractor. Open the valve (D) and adjust the pressure to the required value using the tractor hydraulics. Close the valve (D) and repositioning the hose in its original position.

**NOTE:** The plough must be connected to the tractor when adjusting the pressure and when depressurizing the system. Always ensure maximum cleanliness when working with the hydraulic system.

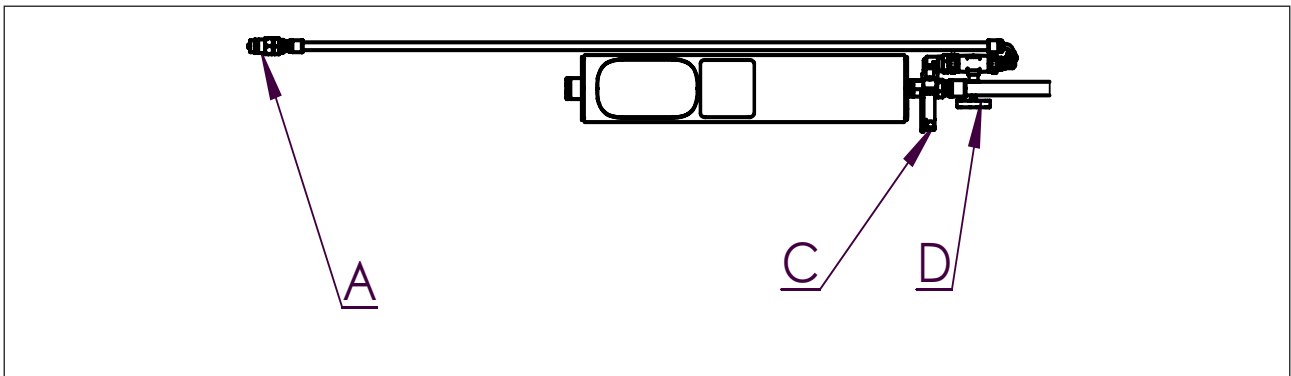

**Never attempt to disconnect any hydraulic connection while the system is pressurized.**

#### Changing of the working pressure (mechanically)

In extremely heavy and resistant soils, where consistently high working pressures (above 13 MPa) are required to prevent the plough bodies from tripping due to soil resistance, the trip resistance can be increased mechanically. This mainly applies to ploughs with the beam height of 75cm (ploughs with a beam height of 80cm are standardly fitted this way).



## 4. STONE TRIP SYSTEM

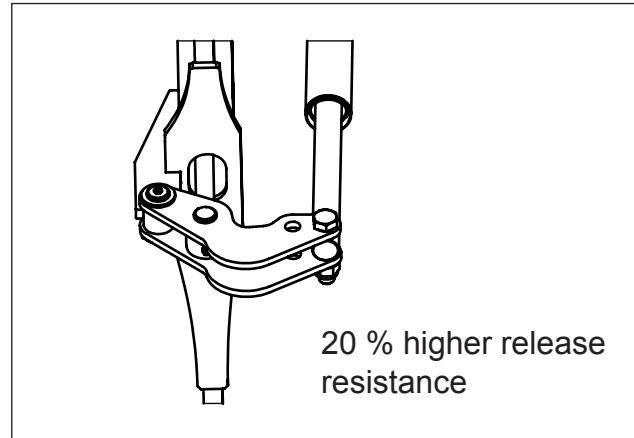
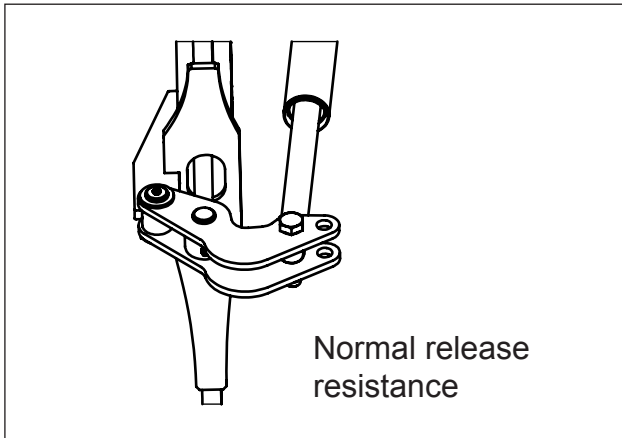

**Adjustment:** Connect the filling hose for the stone trip system as described in the preceding ADJUSTMENT OF OPERATING PRESSURE, and depressurize the system.

Remove the piston rod from inner hole and relocate it in to the outer hole, this increases the leverage, which results in a 20% increase of the resistance.

## CHECKING THE ACCUMULATOR

**The plough must be mounted to the tractor!**

The accumulator precharge pressure should be checked at regular intervals (yearly) with the help of the pressure gauge.

Connect the filling hose as described in “ADJUSTMENT OF WORKING PRESSURE”, set the control lever on the tractor to the open return position and open the shut-off valve slightly. The working pressure will now drop slowly to a specific value and then fall rapidly to zero.

The pressure shown by the gauge at which the rapid drop occurs is the accumulator precharge pressure.

In a similar manner, the precharge pressure can be checked when filling. In this case, the reading will rise rapidly from 0 to a specific value, after which it will increase slowly. The pressure gauge reading at the end of the rapid rise in pressure is the accumulator precharge pressure.

**SUMMARY:** The pressure at which the gauge reading drops quickly when emptying the system and at which the reading stops rising quickly when filling the system, is the accumulator precharge pressure.

Should the pressure fall by more than 2 MPa (20 bar) below the precharge pressure specified on the accumulator, contact your local dealer for advice.



**Never tamper with the gas filling valve. Never attempt to disconnect a hydraulic connection while the system is pressurized.  
The plough must be mounted to the tractor!**

## 5. DRIVING A REVERSIBLE PLOUGH

- Road transport: Always remember that a relatively considerable weight is resting on the rear axle of the tractor. To ensure that the tractor retains its steering properties, fit front weights as required.
- Driving speeds, transport: Adapt driving speed to the road conditions so that the plough does not bounce behind the tractor this could alter the plough settings and impose abnormal stresses on it.  
Maximum transport speed 25 km/h (16 mph).
- Ploughing: Adapt ploughing speed to the prevailing ground conditions and presence of stones.  
NOTE: Excessively high speed costs money in terms of wear and damage to equipment.
- Turning on headlands: After turning on headlands, always ensure that entry is made from the unploughed side. Turning on headland can be done in two different ways:
- Three-point turn: This consists of raising the plough at the headland mark, turning towards the unploughed side, reversing towards the ploughed side, driving forward and then lowering the plough at the headland mark. The plough should preferably be turned-over while driving forward or at standstill.
- 360° Turn: Start by raising the plough at the headland mark, immediately followed by a 360° turn starting off towards the ploughed side, re-approaching from the unploughed side and lowering the plough at the headland mark. The plough can be turned over any time during the turn..

The method chosen will differ from driver to driver and to some extent, also on the type of tractor. The three-point turn requires more work for the driver, but requires a smaller headland, while the 360° turn, although faster, requires less labour and a somewhat wider headland.

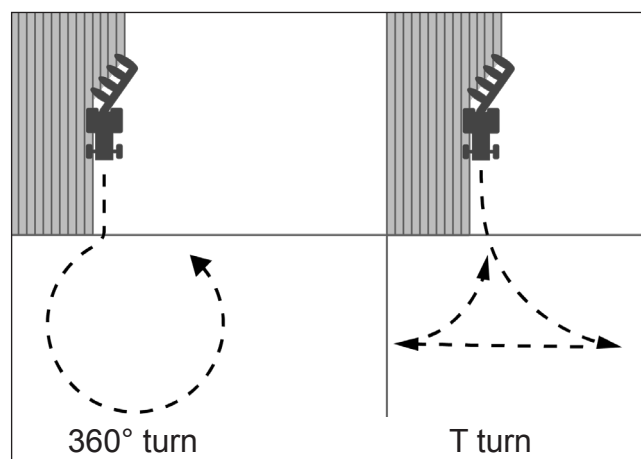

### USEFUL OPERATIONAL POINTS

#### Marking of headlands

Always mark the headlands, working inward, towards the field with the rear body, (i.e. with an extended top-link and the front end of the plough raised).

In good regular fields, headland marking is only necessary at the short sides. In irregular fields or fields surrounded by ditches, hedges or other obstacles, the headlands should be marked out all around the field.

#### Headland width

Headlands should always be of an adequate width to permit the plough to be fully raised out of the ground before starting to turn the tractor. Depending on the size of the tractor and plough, and the method of turning on the headland (reversing or making a 360° turn), the headland width should be between 10 - 20 meters.

#### Ploughing

When starting ploughing at the edge of the field or at the side headland (if marked out all around), the first furrow slice should be laid inwards using the same plough setting as when marking the headlands. Ploughing begins with the second run in which the first furrow slice is returned. All the soil will by this be ploughed through completely. On the third run, the tractor will be running in a furrow at the correct depth and the basic settings should be adjusted.

#### LOWERING AND RAISING OF THE PLOUGH SHOULD BE CARRIED OUT AT THE HEADLAND MARKS.

An even edge at the headland marking will make it easier to plough the headlands and eliminate double ploughing.

**Drive Straight!** Crooked furrows impose high stress on both tractor and plough, and contribute to an unsatisfactory result due to poor matching. Consequently, the furrows should be straightened as quickly as possible.

Always use the plough bodies alternately to equalise the wear on both right and left hand sides, otherwise, it will be impossible to produce uniform furrow slices on both sides.

#### Select the correct furrow width

The working width must always be proportional to the ploughing depth, i.e. the maximum depth should not exceed 2/3 of the furrow width. This to ensure that the furrow slices are correctly balanced and turned over.

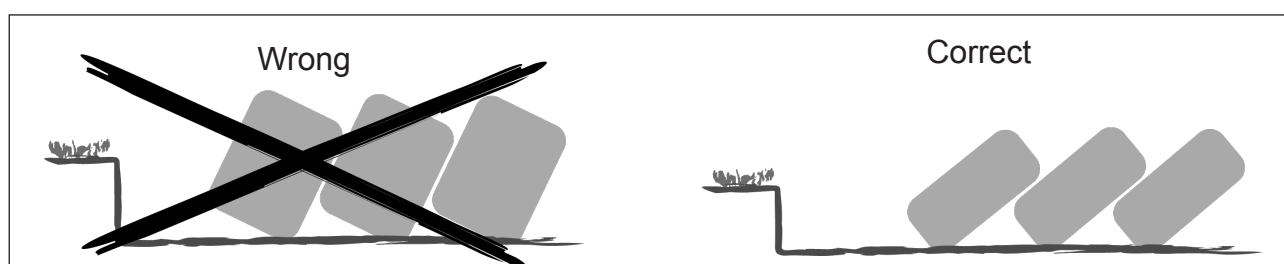

## 6. MAINTENANCE

To ensure the plough a long life and to avoid unnecessary wear, observe the following instructions.

The plough comes with three wrenches. The wrenches are used for re-tightening the bolts and for replacing the wear parts.

### REPLACEMENT OF WEARING PARTS

All wearing parts should be replaced in good time in order to protect more vital parts, which will save you money. Always use original spare parts, which will ensure that you get wearing parts with good quality and which fit the plough. This is also a condition for validity of the warranty.

#### Point and Shares

The points and shares must be replaced before it has been worn down so far that the frog is damaged.

#### Mouldboards

When replacing mouldboards, ensure that the bolts are CROSS-TIGHTENED in order to avoid tension being built into the mouldboard, which may cause it to crack.

#### Mouldboard shin

When replacing the mouldboard shin, ensure that the bolts are CROSS-TIGHTENED in order to avoid tension being built into the mouldboard shin, which may cause it to crack.

#### Landsides

If the landsides are severely worn, the plough will break out towards the unploughed soil which gives a poorer turning of the furrow slice and the plough will pull heavier.

#### Disc coulter blades

If a good cutting function should be maintained, the coulter blade should be replaced when 1/3 of the original diameter is worn off.



- **The plough must be mounted on the tractor!**
- **Never carry out adjustment or replacing wearing parts unless the tractor engine is stopped and the plough is louvered to level ground.**
- **Never work under a raised plough without securing it with a stand or similar, to avoid accidental lowering of the plough.**
- **Never rely solely on the tractor hydraulic system.**
- **Always wear gloves and protective goggles when handling worn implement parts with sharp edges.**

## PARALLELISM AND G-MEASUREMENT OF THE MOULDBOARDS

- Check the working angle of the mouldboard. The normal position is measured on the rear plough body between the extended inside line of the landside, horizontally out against the outermost hole in the mouldboard, see measurement **G**. Adjust the mouldboard stay if necessary

XL	Mouldboard normal measurement	G = 580 mm
XLD	Mouldboard normal measurement	G = 670 mm
XU	Mouldboard normal measurement	G = 625 mm
UC	Mouldboard normal measurement	G = 550 mm
XS	Measurement to the outer end of the bottom slat	= 635 mm
	Measurement to the outer end of the top slat	= 505 mm

- Repeat the same procedure for the rear body on the opposite side.
- Measure from the now adjusted rear, two bodies forward and adjust the mouldboard stays if necessary, to the interbody space 900-1000 mm **A= B**.

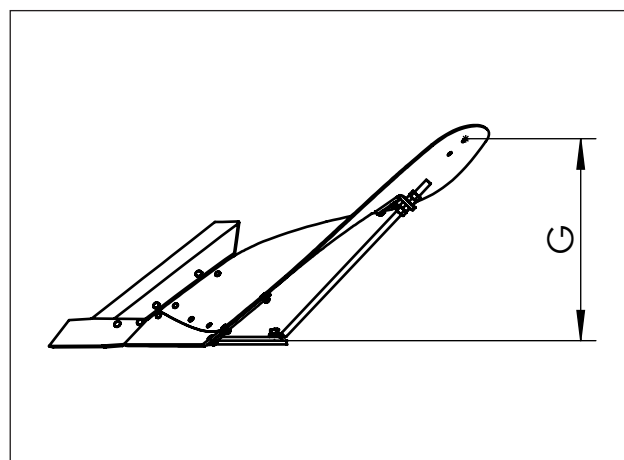
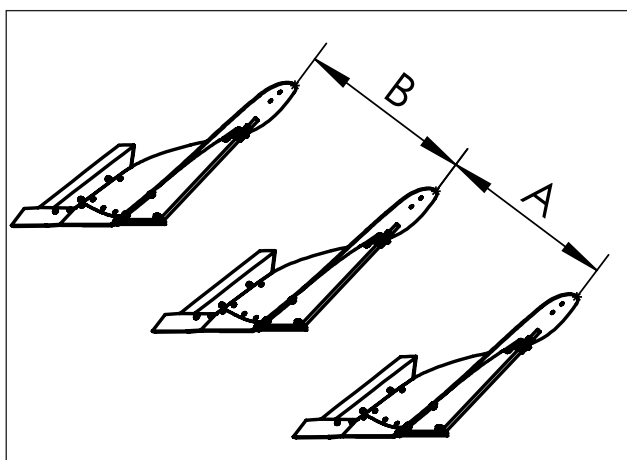

## TIGHTENING THE BOLTS

Bolts of quality 8.8, 10.9 and 12.9 are used on the ploughs. When replacing these bolts, ensure that the same quality bolts and nuts are used. It is easier to tighten bolts and nuts to correct tightening torque, if they are lubricated with oil.

### Tightening torque's

<u>Quality</u>	<u>Size</u>	<u>Torque</u>			
		Dry bolts and nuts		Bolts and nuts lubricated with oil	
8,8	M12	81	Nm	70	Nm
8,8	M16	197	Nm	170	Nm
8,8	M18	275	Nm	236	Nm
8,8	M20	385	Nm	330	Nm
8,8	M24	665	Nm	572	Nm
8,8	M30	1310	Nm	1127	Nm
10,9	M12	114	Nm	98	Nm
10,9	M16	277	Nm	238	Nm
10,9	M20	541	Nm	465	Nm
10,9	M24	935	Nm	804	Nm
10,9	M30	1840	Nm	1582	Nm
12,9	M16*	333	Nm	286	Nm
12,9	M20	649	Nm	558	Nm
12,9	M24	1120	Nm	963	Nm

\* The M16 screws that are mounted through the link plates but outside the main frame should be tightened to 200 Nm

## GREASING OF THE BEAM HINGE POINTS

Grease the beam hinge points weekly, in stony conditions more frequently.

Procedure: Position the plough with the bodies approx. 15 cm above the ground. For depressurising the accumulators, see section 4. STONE TRIP SYSTEM, CHECKING THE ACCUMULATOR.

The hinge points will now expose as the beams drop down. Grease all the upper hinge points (MoS2 grease is recommended). Also grease all other lubricating points in the stone trip linkage while depressurized. Now pressurise the accumulators, make sure that the beams return to their correct positions. Reverse the plough and repeat the procedure. Charge the accumulators up to the correct operating pressure!

**NOTE!** Make sure that all beams return to their correct positions.

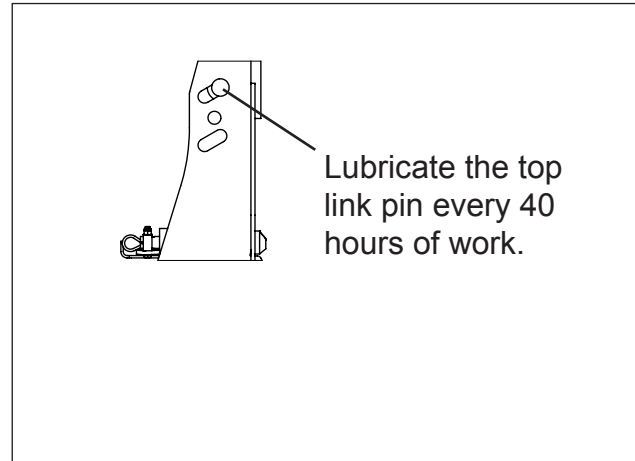
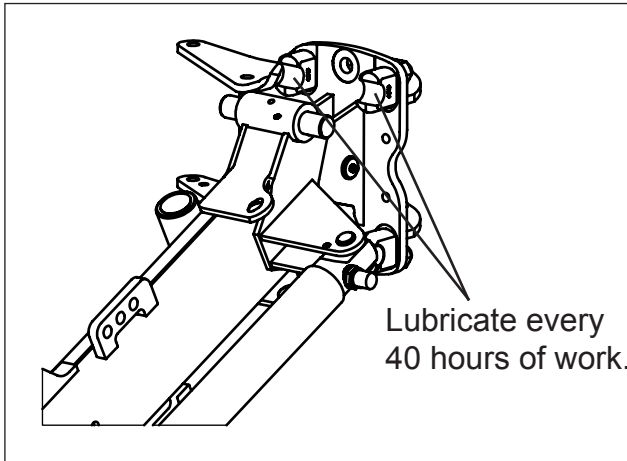

## TYRE PRESSURE

Tyre	Recommended	Pressure
7.00-12	250kPa	2,5 bar
10.0/80-12	300kPa	3,0 bar
26x12.00-12	270kPa	2,7 bar
10.5/80-16	300kPa	3,0 bar
340/55-16	300kPa	3,0 bar

## WINTER STORAGE

- Clean the plough properly
- Ensure that all wearing parts are in good condition, replace if necessary (so that the plough is ready for the next season)
- Tighten all bolts and nuts
- Check the pre-charge pressure in the accumulator
- Lubricate all lubrication points with grease and oil
- Protect the mouldboards and all the shiny details by lubricating them with either oil, under coat protection or acid-free grease
- The stone trip system should be stored in a pressurised condition so that all trip cylinders are fully extended and filled with oil
- Check the hydraulic hoses on the stone trip system and replace any damaged parts

**Always use original spare parts!**

# LUBRICATION CHART

## VARI FLEX CX, VARI FLEX CX PLUS

Lubricate the places indicated in the chart below at the indicated time interval.

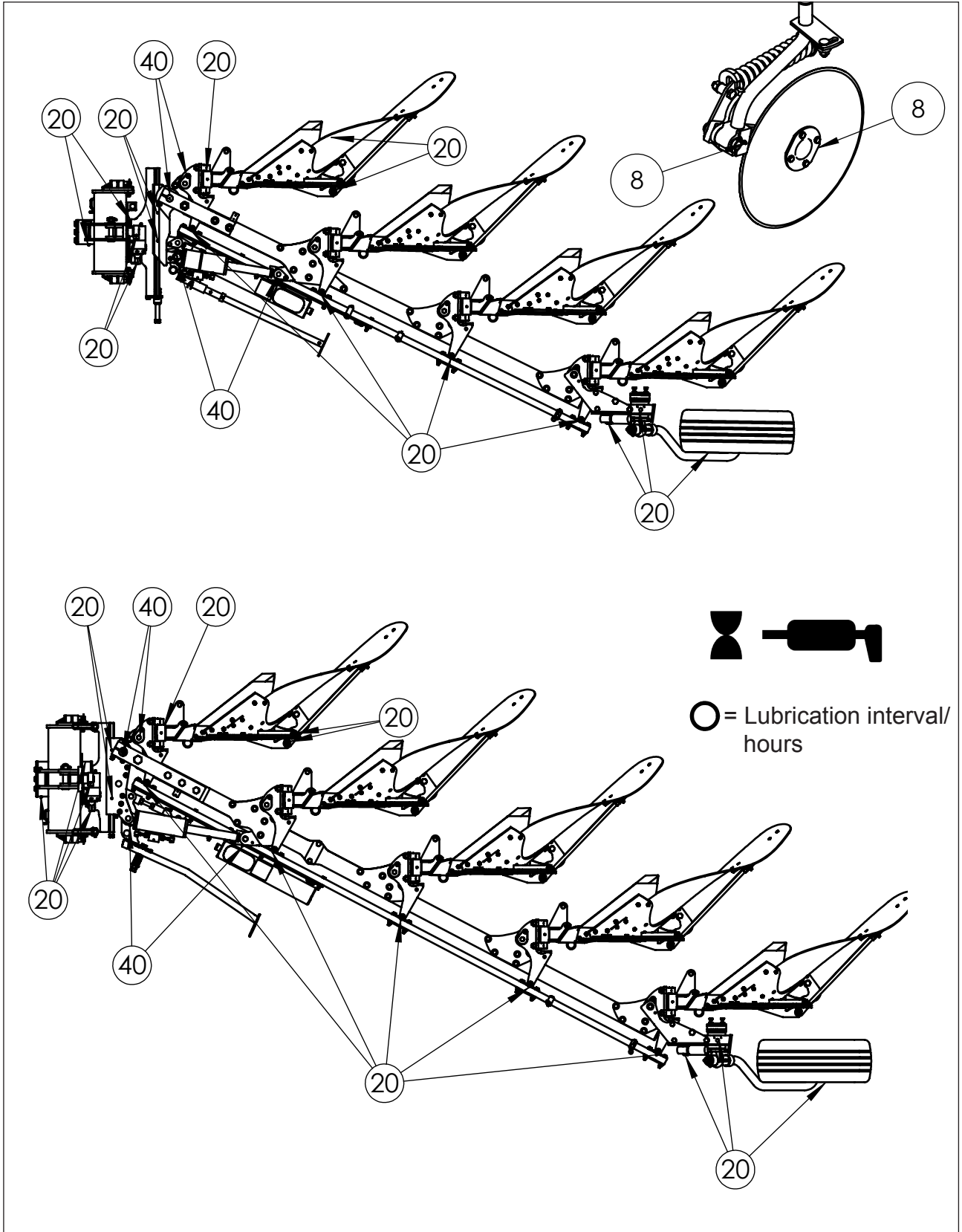



VARI FLEX EX

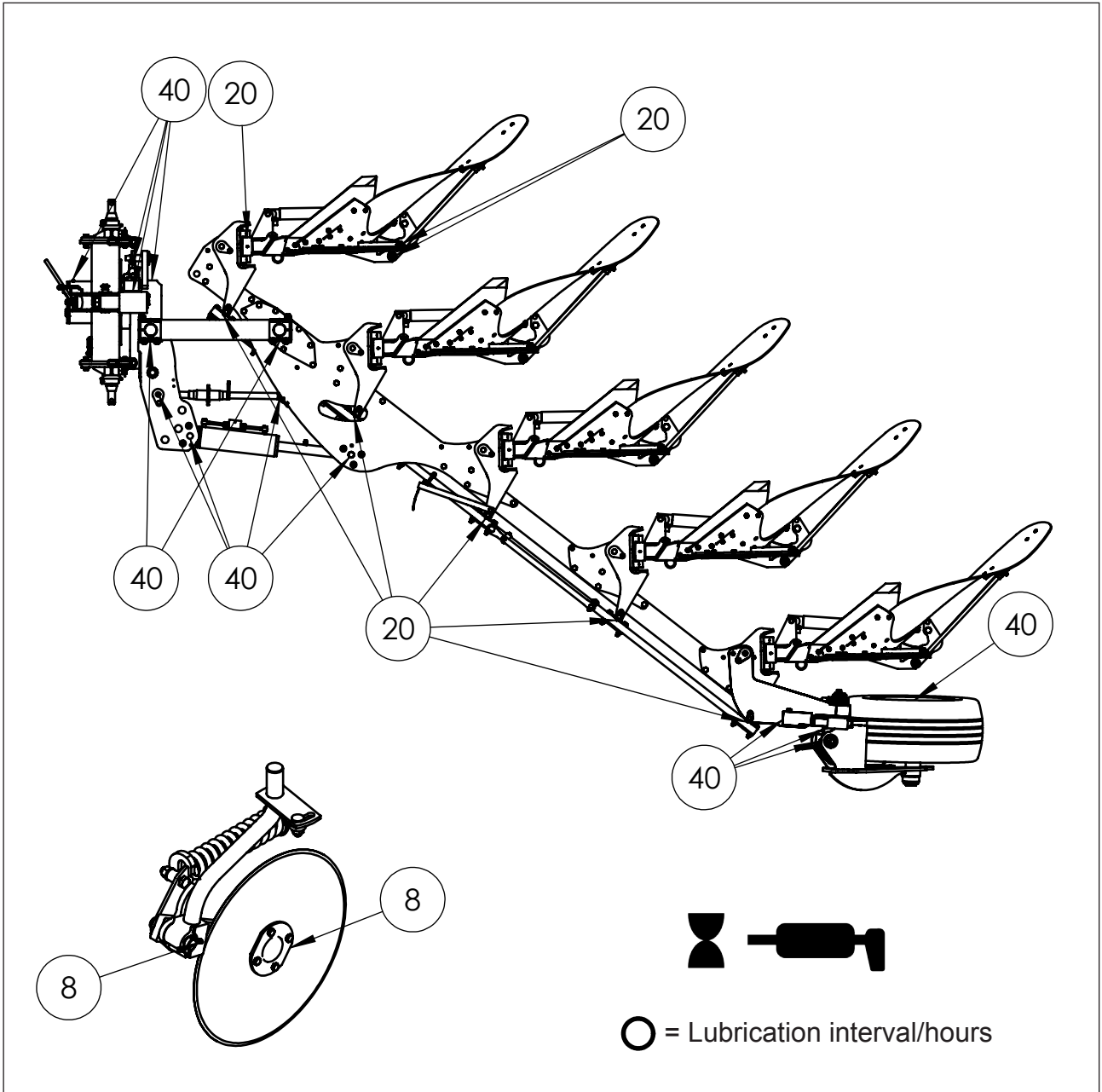

### CHANGING THE TURN-OVER DIRECTION

The Vari Flex CX-ploughs can be mounted for turning either over or under.

The plough are normally mounted with the bodies turning under. When using furrow press arm, turning the bodies over is recommended.



**Note: Ploughs equipped with alignment cylinder has different types of turn over valves for turning over or under.**

### CHANGING THE TURN-OVER DIRECTION

1. Park the plough and disconnect the tractor from the plough.
2. Dismount the screws in the front of the turn-over axle (2).
3. Remove the turn-over cylinder (3) from its lower attachment point. Remove the headstock with turn-over cylinder.

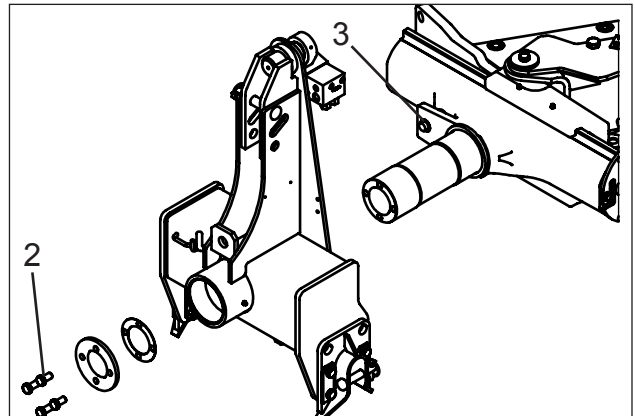
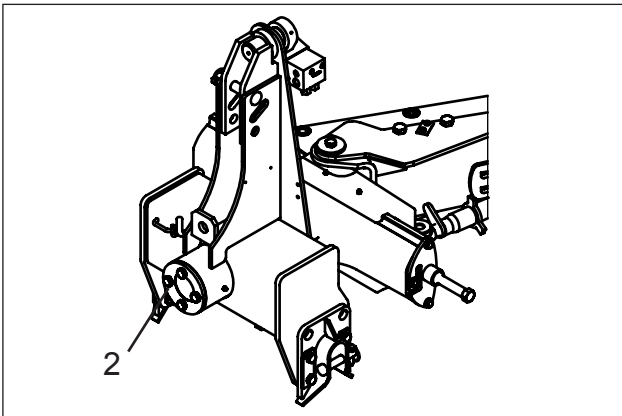

4. Remove the threaded rod alt. the cylinder for the first furrow adjustment.

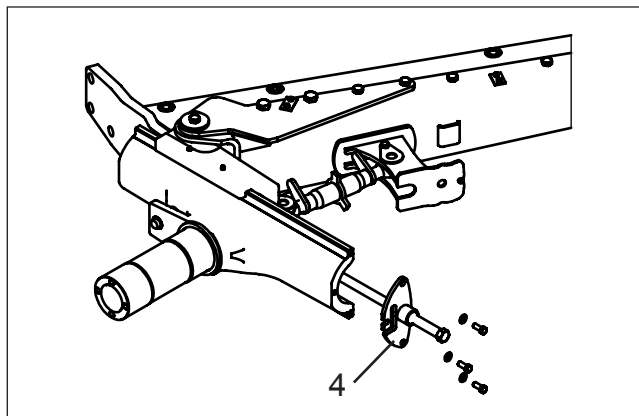

## 6. MAINTENANCE

---

5. Pull out the turn-over axle (**A**) from the turn-over arm (**B**). Turn the turn-over axle 180° and push the turn-over axle in to the turn-over arm. The rod of the turn-over cylinder will now be on the other side of the turn-over axle.

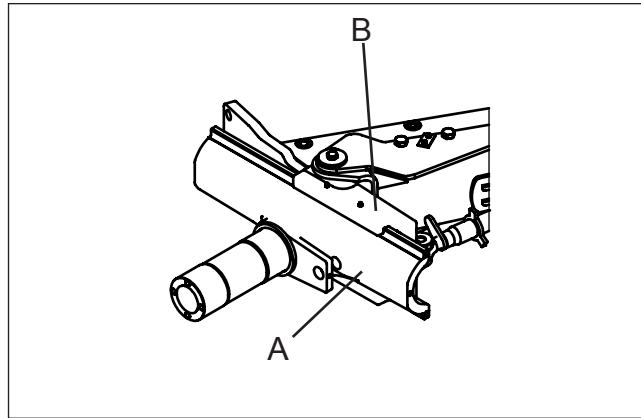

6. Reassemble the threaded rod alt. the cylinder for the first furrow.
7. Reassemble the headstock and turn-over cylinder. Use locking fluid for the four screws on the turn-over axle and pull them to right torque, 238 Nm.

## 7. USEFUL ADVICE

When you have completed a careful and accurate adjustment of your plough so that it works well and gives a good result, make a note of the following important measurements:

Length of the lift rods \_\_\_\_\_

Length of top link \_\_\_\_\_

Left vertical adjustment screw \_\_\_\_\_

Right vertical adjustment screw \_\_\_\_\_

A-measurement \_\_\_\_\_

B-measurement (first furrow width adjustment) \_\_\_\_\_

Adjustment sleeves combi-wheel \_\_\_\_\_

These measurements and similar notes will make the adjustments easier next time you start ploughing.

## 8. LIFTING POINTS

VARI FLEX CX

Max weight: 1975 Kg

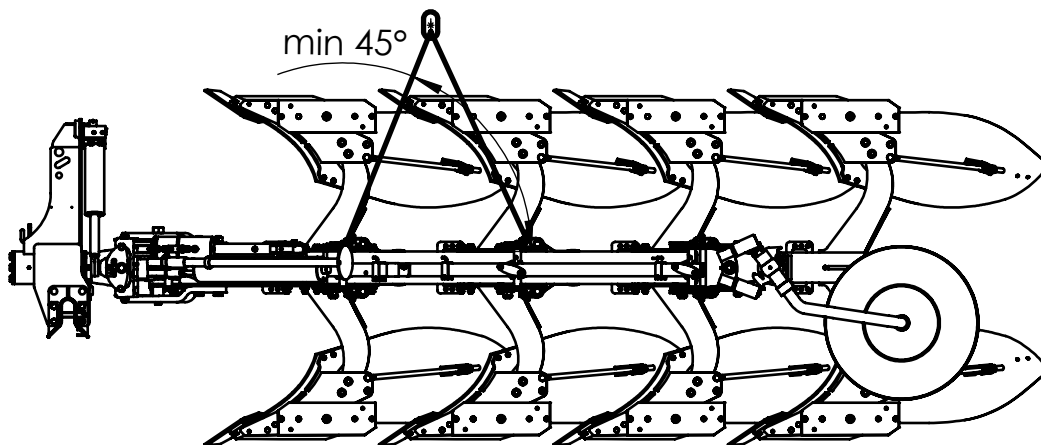

## 8. LIFTING POINTS

### VARI FLEX CX PLUS

Max weight: 2485 Kg

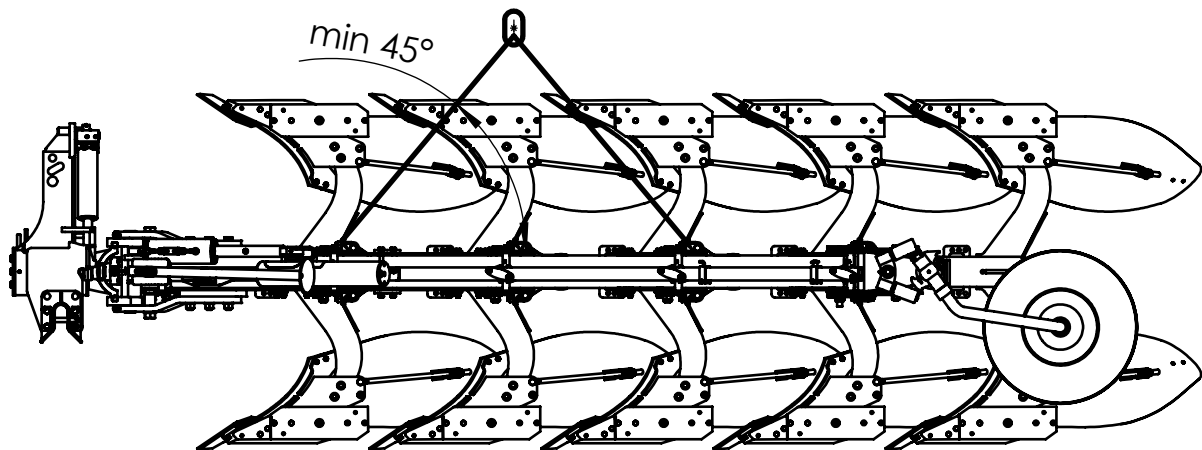

## 8. LIFTING POINTS

---

### VARI FLEX EX

Max weight: 3280 Kg

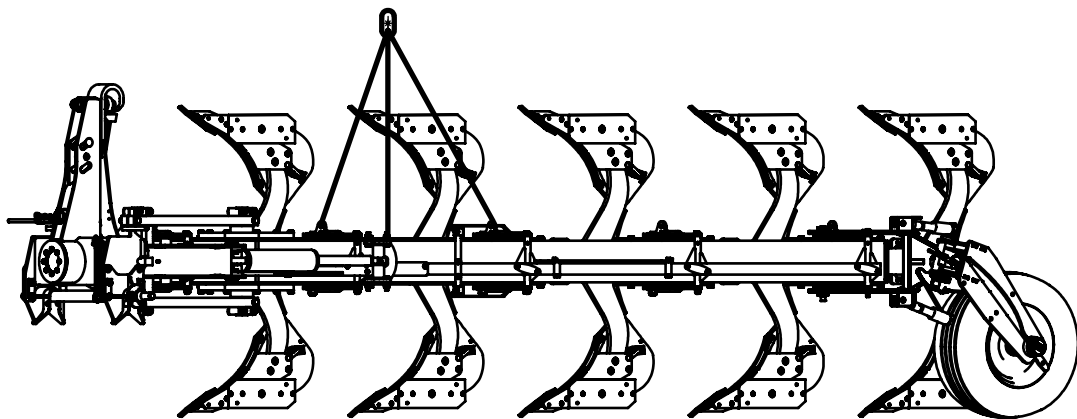

## 9. BASIC A-MEASUREMENTS

### **A-measurement for Vari Flex CX - Ploughs**

Vari Flex CX H: 317 mm

Vari Flex CX F: 350 mm

### **A-measurement for Vari Flex CX Plus - Ploughs**

Vari Flex CX Plus H: 323 mm

Vari Flex CX Plus F: 323 mm

### **A-measurement for Vari Flex EX - Ploughs**

Vari Flex EX H: 690 mm

Vari Flex EX F: 690 mm



## 10. TECHNICAL DATA

Model Vari Flex CX H	Distance between plough bodies pairs (cm)	Under beam clearance (cm)	No. of plough body pairs	Work width (cm)	Recommended tractor size (hp)	Machine weight* (kg)	Lifting capacity approx. (kg)
3975	90	75/80	3	90-150	70-110	1225	2900
4975	90	75/80	4	120-200	90-160	1450	3500
31075	100	75/80	3	90-150	70-110	1250	3000
41075	100	75/80	4	120-150	90-160	1475	3500

\* Equipment: Support wheel, one pair of disc coulters, other knife coulters

Model Vari Flex CX F	Distance between plough bodies pairs (cm)	Under beam clearance (cm)	No. of plough body pairs	Work width (cm)	Recommended tractor size (hp)	Machine weight* (kg)	Lifting capacity approx. (kg)
3975	90	75/80	3	90-150	60-100	1100	2600
4975	90	75/80	4	120-200	90-160	1290	3100
5975	90	75/80	5	150-250	90-160	1480	3500
31075	100	75/80	3	90-150	70-120	1120	2700
41075	100	75/80	4	120-200	90-160	1310	3100

\* Equipment: Support wheel, one pair of disc coulters, other knife coulters

Model Vari Flex CX Plus H	Distance between plough bodies pairs (cm)	Under beam clearance (cm)	No. of plough body pairs	Work width (cm)	Recommended tractor size (hp)	Machine weight* (kg)	Lifting capacity approx. (kg)
4975	90	75/80	4	120-200	90-160	1590	3800
5975	90	75/80	5	150-250	140-200	1810	4400
41075	100	75/80	4	120-200	90-160	1620	3900
51075	100	75/80	5	150-250	140-200	1840	4400

\* Equipment: Support wheel, one pair of disc coulters, other knife coulters

Model Vari Flex CX Plus F	Distance between plough bodies pairs (cm)	Under beam clearance (cm)	No. of plough body pairs	Work width (cm)	Recommended tractor size (hp)	Machine weight* (kg)	Lifting capacity approx. (kg)
4975	90	75/80	4	120-200	90-160	1430	3400
5975	90	75/80	5	150-250	120-200	1610	3800
41075	100	75/80	4	120-200	90-160	1460	3500
51075	100	75/80	5	150-250	120-200	1640	4000

\* Equipment: Support wheel, one pair of disc coulters, other knife coulters

## 10. TECHNICAL DATA

Model Vari Flex EX H	Distance between plough bodies pairs (cm)	Under beam clearance (cm)	No. of plough body pairs	Work width (cm)	Recom- mended tractor size (hp)	Machine weight* (kg)	Lifting capacity approx. (kg)
4975	90	75/80	4	120-220	140-220	2040	4900
5975	90	75/80	5	150-275	175-250	2290	5500
6975	90	75/80	6	180-330	220-300	2540	6100
41075	100	75/80	4	140-200	140-220	2065	5000
51075	100	75/80	5	175-275	175-250	2315	5600

\* Equipment: Combi wheel, one pair of disc coulters, other knife coulters

Model Vari Flex EX F	Distance between plough bodies pairs (cm)	Under beam clearance (cm)	No. of plough body pairs	Work width (cm)	Recom- mended tractor size (hp)	Machine weight* (kg)	Lifting capacity approx. (kg)
4975	90	75/80	4	120-220	140-200	1940	4600
5975	90	75/80	5	150-275	175-250	2075	5000
6975	90	75/80	6	180-330	210-300	2220	5300
41075	100	75/80	4	140-220	175-250	1965	5000
51075	100	75/80	5	175-275	175-250	2100	5000
61075	100	75/80	6	210-330	210-300	2240	5400

\* Equipment: Combi wheel, one pair of disc coulters, other knife coulters

## 10. TECHNICAL DATA

---

