

Publication No. 421
April 2002
Part No. 41570.21
Revised: 26.03.19

TOPPER 9

ROTARY MOWER



Operator Manual



IMPORTANT

VERIFICATION OF WARRANTY REGISTRATION

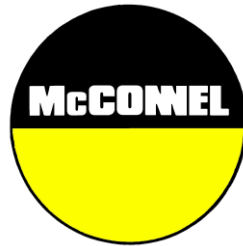

DEALER WARRANTY INFORMATION & REGISTRATION VERIFICATION

It is imperative that the selling dealer registers this machine with McConnel Limited before delivery to the end user – failure to do so may affect the validity of the machine warranty.

To register machines go to the McConnel Limited web site at www.mcconnel.com, log onto 'Dealer Inside' and select the 'Machine Registration button' which can be found in the Service Section of the site. Confirm to the customer that the machine has been registered in the section below.

Should you experience any problems registering a machine in this manner please contact the McConnel Service Department on 01584 875848.

Registration Verification

Dealer Name:
Dealer Address:
Customer Name:
Date of Warranty Registration:/...../..... Dealer Signature:

NOTE TO CUSTOMER / OWNER

Please ensure that the above section above has been completed and signed by the selling dealer to verify that your machine has been registered with McConnel Limited.

IMPORTANT: During the initial 'bedding in' period of a new machine it is the customer's responsibility to regularly inspect all nuts, bolts and hose connections for tightness and re-tighten if required. New hydraulic connections occasionally weep small amounts of oil as the seals and joints settle in – where this occurs it can be cured by re-tightening the connection – refer to torque settings chart below. The tasks stated above should be performed on an hourly basis during the first day of work and at least daily thereafter as part of the machines general maintenance procedure.

CAUTION: DO NOT OVER TORQUE HYDRAULIC FITTINGS AND HOSES

TORQUE SETTINGS FOR HYDRAULIC FITTINGS

HYDRAULIC HOSE ENDS		
BSP	Setting	Metric
1/4"	18 Nm	19 mm
3/8"	31 Nm	22 mm
1/2"	49 Nm	27 mm
5/8"	60 Nm	30 mm
3/4"	80 Nm	32 mm
1"	125 Nm	41 mm
1.1/4"	190 Nm	50 mm
1.1/2"	250 Nm	55 mm
2"	420 Nm	70 mm

PORT ADAPTORS WITH BONDED SEALS		
BSP	Setting	Metric
1/4"	34 Nm	19 mm
3/8"	47 Nm	22 mm
1/2"	102 Nm	27 mm
5/8"	122 Nm	30 mm
3/4"	149 Nm	32 mm
1"	203 Nm	41 mm
1.1/4"	305 Nm	50 mm
1.1/2"	305 Nm	55 mm
2"	400 Nm	70 mm

WARRANTY POLICY

WARRANTY REGISTRATION

All machines must be registered, by the selling dealer with McConnel Ltd, before delivery to the end user. On receipt of the goods it is the buyer's responsibility to check that the Verification of Warranty Registration in the Operator's Manual has been completed by the selling dealer.

1. LIMITED WARRANTIES

- 1.01. *All mounted machines supplied by McConnel Ltd are warranted to be free from defects in material and workmanship from the date of sale to the original purchaser for a period of 12 months, unless a different period is specified.*
All Self Propelled Machines supplied by McConnel Ltd are warranted to be free from defects in material and workmanship from the date of sale to the original purchaser for a period of 12 months or 1500 hours. Engine warranty will be specific to the Manufacturer of that unit.
- 1.02. *All spare parts supplied by McConnel Ltd and purchased by the end user are warranted to be free from defects in material and workmanship from the date of sale to the original purchaser for a period of 6 months. All parts warranty claims must be supported by a copy of the failed part invoice to the end user. We cannot consider claims for which sales invoices are not available.*
- 1.03. *The warranty offered by McConnel Ltd is limited to the making good by repair or replacement for the purchaser any part or parts found, upon examination at its factory, to be defective under normal use and service due to defects in material or workmanship. Returned parts must be complete and unexamined. Pack the component(s) carefully so that any transit damage is avoided. All ports on hydraulic items should be drained of oil and securely plugged to prevent seepage and foreign body ingress. Certain other components, electrical items for example, may require particular care when packing to avoid damage in transit.*
- 1.04. *This warranty does not extend to any product from which McConnel Ltd's serial number plate has been removed or altered.*
- 1.05. *The warranty policy is valid for machines registered in line with the terms and conditions detailed and on the basis that the machines do not extend a period of 24 months or greater since their original purchase date, that is the original invoice date from McConnel Limited.*
Machines that are held in stock for more than 24 months cannot be registered for warranty.
- 1.06. *This warranty does not apply to any part of the goods, which has been subjected to improper or abnormal use, negligence, alteration, modification, fitment of non-genuine parts, accident damage, or damage resulting from contact with overhead power lines, damage caused by foreign objects (e.g. stones, iron, material other than vegetation), failure due to lack of maintenance, use of incorrect oil or lubricants, contamination of the oil, or which has served its normal life. This warranty does not apply to any expendable items such as blades, belts, clutch linings, filter elements, flails, flap kits, skids, soil engaging parts, shields, guards, wear pads, pneumatic tyres or tracks.*
- 1.07. *Temporary repairs and consequential loss - i.e. oil, downtime and associated parts are specifically excluded from the warranty.*
- 1.08. *Warranty on hoses is limited to 12 months and does not include hoses which have suffered external damage. Only complete hoses may be returned under warranty, any which have been cut or repaired will be rejected.*
- 1.09. *Machines must be repaired immediately a problem arises. Continued use of the machine after a problem has occurred can result in further component failures, for which McConnel Ltd cannot be held liable, and may have safety implications.*
- 1.10. *If in exceptional circumstances a non McConnel Ltd part is used to effect a repair, warranty reimbursement will be at no more than McConnel Ltd's standard dealer cost for the genuine part.*

- 1.11. *Except as provided herein, no employee, agent, dealer or other person is authorised to give any warranties of any nature on behalf of McConnell Ltd.*
- 1.12. *For machine warranty periods in excess of 12 months the following additional exclusions shall apply:*
 - 1.12.1. *Hoses, exposed pipes and hydraulic tank breathers.*
 - 1.12.2. *Filters.*
 - 1.12.3. *Rubber mountings.*
 - 1.12.4. *External electric wiring.*
 - 1.12.5. *Bearings and seals*
 - 1.12.6. *External Cables, Linkages*
 - 1.12.7. *Loose/Corroded Connections, Light Units, LED's*
 - 1.12.8. *Comfort items such as Operator Seat, Ventilation, Audio Equipment*
- 1.13. *All service work, particularly filter changes, must be carried out in accordance with the manufacturer's service schedule. Failure to comply will invalidate the warranty. In the event of a claim, proof of the service work being carried out may be required.*
- 1.14. *Repeat or additional repairs resulting from incorrect diagnosis or poor quality previous repair work are excluded from warranty.*

NB Warranty cover will be invalid if any non-genuine parts have been fitted or used. Use of non-genuine parts may seriously affect the machine's performance and safety. McConnell Ltd cannot be held responsible for any failures or safety implications that arise due to the use of non-genuine parts.

2. REMEDIES AND PROCEDURES

- 2.01. *The warranty is not effective unless the Selling Dealer registers the machine, via the McConnell web site and confirms the registration to the purchaser by completing the confirmation form in the operator's manual.*
- 2.02. *Any fault must be reported to an authorised McConnell Ltd dealer as soon as it occurs. Continued use of a machine, after a fault has occurred, can result in further component failure for which McConnell Ltd cannot be held liable.*
- 2.03. *Repairs should be undertaken within two days of the failure. Claims submitted for repairs undertaken more than 2 weeks after a failure has occurred, or 2 days after the parts were supplied will be rejected, unless the delay has been authorised by McConnell Ltd. Please note that failure by the customer to release the machine for repair will not be accepted as a reason for delay in repair or submitting warranty claims.*
- 2.04. *All claims must be submitted, by an authorised McConnell Ltd Service Dealer, within 30 days of the date of repair.*
- 2.05. *Following examination of the claim and parts, McConnell Ltd will pay, at their discretion, for any valid claim the invoiced cost of any parts supplied by McConnell Ltd and appropriate labour and mileage allowances if applicable.*
- 2.06. *The submission of a claim is not a guarantee of payment.*
- 2.07. *Any decision reached by McConnell Ltd. is final.*

3. LIMITATION OF LIABILITY

- 3.01. *McConnell Ltd disclaims any express (except as set forth herein) and implied warranties with respect to the goods including, but not limited to, merchantability and fitness for a particular purpose.*
- 3.02. *McConnell Ltd makes no warranty as to the design, capability, capacity or suitability for use of the goods.*
- 3.03. *Except as provided herein, McConnell Ltd shall have no liability or responsibility to the purchaser or any other person or entity with respect to any liability, loss, or damage caused or alleged to be caused directly or indirectly by the goods including, but not limited to, any indirect, special, consequential, or incidental damages resulting from the use or operation of the goods or any breach of this warranty. Notwithstanding the above limitations and warranties, the manufacturer's liability hereunder for damages incurred by the purchaser or others shall not exceed the price of the goods.*
- 3.04. *No action arising out of any claimed breach of this warranty or transactions under this warranty may be brought more than one (1) year after the cause of the action has occurred.*

4. MISCELLANEOUS

- 4.01. McConnel Ltd may waive compliance with any of the terms of this limited warranty, but no waiver of any terms shall be deemed to be a waiver of any other term.*
- 4.02. If any provision of this limited warranty shall violate any applicable law and is held to be unenforceable, then the invalidity of such provision shall not invalidate any other provisions herein.*
- 4.03. Applicable law may provide rights and benefits to the purchaser in addition to those provided herein.*

McConnel Limited



DECLARATION OF CONFORMITY

Conforming to EU Machinery Directive 2006/42/EC

We,

McCONNEL LIMITED, Temeside Works, Ludlow, Shropshire SY8 1JL, UK

Hereby declare that:

The Product; *Tractor Trailed Rotary Mower / Topper*

Product Code; *TOP9*

Serial No. & Date Type

Manufactured in; *United Kingdom*

Complies with the required provisions of the Machinery Directive 2006/42/EC
The machinery directive is supported by the following harmonized standards;

- BS EN ISO 12100 (2010) Safety of machinery – General principles for design – Risk assessment and risk reduction.
- BS EN 349 (1993) + A1 (2008) Safety of machinery - Minimum distances to avoid the entrapment with human body parts.
- BS EN ISO 14120 (2015) Safety of machinery - Guards general requirements for the design and construction of fixed and movable guards.
- BS EN 4413 (2010) Hydraulic fluid power. Safety requirements for systems and their components.

McCONNEL LIMITED operates an ISO 9001:2008 quality management system, certificate number: FM25970.

This system is continually assessed by the;

British Standards Institution (BSI), Beech House, Milton Keynes, MK14 6ES, UK

BSI is accredited by UK Accreditation Service, accreditation number: UKAS 003.

The EC declaration only applies if the machine stated above is used in accordance with the operating instructions.

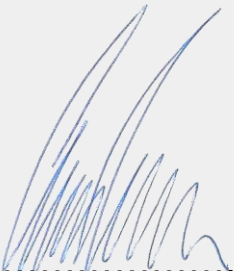
Signed  *Responsible Person*
CHRISTIAN DAVIES on behalf of McCONNEL LIMITED

Status: *General Manager*

Date: *January 2018*

ROTARY MOWER INSPECTION AND MAINTENANCE

A daily equipment inspection of the tractor and mower should be conducted before the equipment is used. You may use the inspection sheets to assist with these daily inspections. Any damaged or missing guards should be repaired or replaced before operating the mower. Failure to repair the damaged shield can result in objects being thrown from the mower and possibly hitting the operator or bystander.

Inspect the Mower for Safe Operating Condition

- Make sure the driveline guards and shielding are in place and in good repair.
- Inspect the chain guards, flexible and/or solid deflector thrown object shielding to assure that they are in place on the front and rear of the mower deck and in good repair. Repair or replace any damaged or missing thrown object shields.
- Remove all debris and cut material from the deck and around the gearboxes.
- Ensure the mower cutting height is set high enough to reduce the possibility of the mower blades contacting the ground. Actual height will be dependent on the ground conditions. Increase the height when working in rough or undulating conditions.
- Inspect for broken, chipped, bent, missing, or severely worn blades. Replace damaged blades before operating the mower. Ensure the blade retaining bolts and fasteners are secure and tight.
- Lubricate the driveline universal joints and telescoping members daily.
- Inspect the wheel lug bolt/nuts to assure that they are tight.
- If mower is equipped with pneumatic tires, make sure they have the required air pressure.
- Inspect for worn or damaged decals and safety instructions. Replace unreadable, damaged or missing safety decals.
- Follow the operator's manual(s) inspection and maintenance instructions for lubricating parts, and keeping thrown object shielding, driveline guards, rotating parts shields, mower blades and decals in good repair.

Inspect the Tractor for Safe Operating Condition:

- Inspect the controls, lights, SMVs (Slow Moving Vehicle sign), seat belts, and ROPS to assure that they are in place and in good working order.
- Be sure the tires, wheels, lug bolts/nuts are in good condition.
- Make sure the tractor brakes and steering are in proper operating condition.
- Follow the operator's manual(s) inspection and maintenance procedures for keeping the tractor in good and safe condition before operating.

The inspection sheet on the following page should be kept in this book as a record. A second sheet is included for you to cut out and photocopy or the inspection sheets can be downloaded from our web site at;

<http://www.mcconnel.com/support/aftersales/default.aspx?nav=After Sales>



MOUNTED ROTARY MOWER PRE-OPERATION Inspection

Mower ID _____ Date: _____ Shift: _____

WARNING



Before conducting the inspection, make sure the tractor engine is off, the key removed, all rotation has stopped and the tractor is in park with the parking brake engaged. Make sure the mower is resting on the ground or securely blocked up.

Item	Condition at start of shift	Specific Comments if not O.K.
The Operator's Manual is in the Canister on the mower		
All Warning Decals are in place, clean and legible		
The mower decks are clear of cut grass and debris		
Chain Guards/Deflectors are in place & in good condition		
Driveline/Gearbox shields/guards are in good condition		
Driveline clutches are in good condition, not frozen		
Driveline telescoping members & u-joints are lubricated		
Driveline yokes are securely attached to tractor & mower		
Gearbox mounting bolts are tight		
Blade carrier retaining nut is tight		
Blades are not chipped, cracked, bent or worn out		
Blade bolts are tight		
Side skirts and skids are in good condition		
There are no holes or cracks in the machine deck		
Wheel nuts are tight		
All linkage mounting pins are securely fastened		
Lift height is restricted to prevent PTO hitting the deck		

Operators Signature: _____

DO NOT OPERATE an UNSAFE TRACTOR or MOWER



TRACTOR PRE-OPERATION Inspection

Power Arm ID _____ Date: _____ Shift: _____

WARNING



Before conducting the inspection, make sure the tractor engine is off, the key is removed all rotation has stopped and the tractor is in park with the parking brake engaged. Any implement attached to the tractor is firmly on the ground.

Item	Condition at start of shift	Specific Comments if not O.K.
The flashing lights function properly.		
All lights are clean and working correctly		
All cab windows are clean and wipers working correctly		
The SMV sign, where required, is clean and visible.		
The tyres are in good condition with correct pressure.		
The wheel nuts are tight.		
The tractor brakes are in good condition.		
The steering linkage is in good condition.		
There are no visible oil leaks.		
The hydraulic controls function properly.		
The ROPS or ROPS cab is in good condition.		
The seatbelt is in place and in good condition.		
The 3-point hitch is in good condition.		
The drawbar/pick up hook is secure & in good condition		
The PTO master shield is in place.		
The engine oil level is full.		
The brake fluid level is full.		
The power steering fluid level is full.		
The fuel level is adequate.		
The engine coolant fluid level is full.		
The radiator & oil cooler are free of debris.		
The air filter is in good condition		

Operators Signature: _____

DO NOT OPERATE an UNSAFE TRACTOR or MOWER



MOUNTED ROTARY MOWER PRE-OPERATION Inspection

Mower ID _____ Date: _____ Shift: _____

WARNING



Before conducting the inspection, make sure the tractor engine is off, the key removed, all rotation has stopped and the tractor is in park with the parking brake engaged. Make sure the mower is resting on the ground or securely blocked up.

Item	Condition at start of shift	Specific Comments if not O.K.
The Operator's Manual is in the Canister on the mower		
All Warning Decals are in place, clean and legible		
The mower decks are clear of cut grass and debris		
Chain Guards/Deflectors are in place & in good condition		
Driveline/Gearbox shields/guards are in good condition		
Driveline clutches are in good condition, not frozen		
Driveline telescoping members & u-joints are lubricated		
Driveline yokes are securely attached to tractor & mower		
Gearbox mounting bolts are tight		
Blade carrier retaining nut is tight		
Blades are not chipped, cracked, bent or worn out		
Blade bolts are tight		
Side skirts and skids are in good condition		
There are no holes or cracks in the machine deck		
Wheel nuts are tight		
All linkage mounting pins are securely fastened		
Lift height is restricted to prevent PTO hitting the deck		

Operators Signature: _____

DO NOT OPERATE an UNSAFE TRACTOR or MOWER



TRACTOR PRE-OPERATION Inspection

Power Arm ID _____ Date: _____ Shift: _____

WARNING



Before conducting the inspection, make sure the tractor engine is off, the key is removed all rotation has stopped and the tractor is in park with the parking brake engaged. Any implement attached to the tractor is firmly on the ground.

Item	Condition at start of shift	Specific Comments if not O.K.
The flashing lights function properly.		
All lights are clean and working correctly		
All cab windows are clean and wipers working correctly		
The SMV sign, where required, is clean and visible.		
The tyres are in good condition with correct pressure.		
The wheel nuts are tight.		
The tractor brakes are in good condition.		
The steering linkage is in good condition.		
There are no visible oil leaks.		
The hydraulic controls function properly.		
The ROPS or ROPS cab is in good condition.		
The seatbelt is in place and in good condition.		
The 3-point hitch is in good condition.		
The drawbar/pick up hook is secure & in good condition		
The PTO master shield is in place.		
The engine oil level is full.		
The brake fluid level is full.		
The power steering fluid level is full.		
The fuel level is adequate.		
The engine coolant fluid level is full.		
The radiator & oil cooler are free of debris.		
The air filter is in good condition		

Operators Signature: _____

DO NOT OPERATE an UNSAFE TRACTOR or MOWER

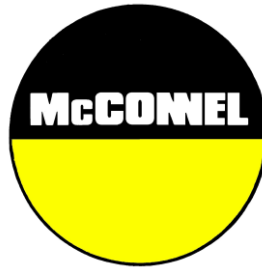

For Safety and Performance...

ALWAYS READ THE BOOK FIRST

McCONEL LIMITED

**Temeside Works
Ludlow
Shropshire
England**

**Telephone: +44 (0)1584 873131
www.mcconel.com**

- NOISE STATEMENT -

The equivalent daily personal noise exposure from this machine measured at the operators' ear is within the range 78 – 85 dB, these figures apply to a normal distribution of use where the noise fluctuates between zero and maximum. The figures assume that the machine is fitted to a tractor with a 'quiet' cab with the windows closed in a generally open environment. We recommend that the windows are kept closed. With the cab rear window open the equivalent daily personal noise exposure will increase to a figure within the range 82 – 88 dB. At an equivalent daily noise exposure level of 85 – 90 dB ear protection is recommended and must always be used if any window is left open.



Operating, servicing and maintaining this equipment can expose you to chemicals including gasoline, diesel fuel, lubricants, petroleum products, engine exhaust, carbon monoxide, and phthalates, which are known to the State of California to cause cancer and birth defects or other reproductive harm. To minimize exposure, avoid breathing exhaust, do not idle the engine except as necessary, service your vehicle in a well-ventilated area and wear gloves or wash your hands frequently when servicing your vehicle. Battery posts, terminals and related accessories contain lead and lead compounds, chemicals known to the state of California to cause cancer, birth defects or other reproductive harm. For more information go to www.P65Warnings.ca.gov. This website, operated by California's Office of Environmental Health Hazard Assessment, provides information about these chemicals and how individuals may be exposed to them.

LIST OF CONTENTS

OPERATION	Page
SAFETY SECTION	
Safety and Warning Information	1
Decal Type and Location	5
Machine Decal Information	6
INTRODUCTION SECTION	
Topper 9 Mower Introduction	7
ASSEMBLY SECTION	
Dealer Setup Instructions	9
A-Frame Assembly	9
Driveline Attachment	10
OPERATION SECTION	
Mower Preparation	11
Tractor Preparation	12
Attaching Mower to Tractor	12
Cutting Height Adjustment	13
Starting and Stopping Mower	13
Cutting Speed	14
Detaching and Storing Mower	15
Driveline Length Check Procedure	15
TROUBLESHOOTING SECTION	
General Troubleshooting	17
PTO Shaft Troubleshooting	18
Gearbox Troubleshooting	18
MAINTENANCE SECTION	
Lubrication Information	20
Lubrication Points	20
Gearbox Lubrication	21
Tail Wheel Lubrication	21
Driveline Lubrication	22
Driveline Shield Removal	22
Blade Servicing	23
Blade Removal	24
Blade Carrier Removal and Installation	24
External Coil Slip Clutch	25
Frozen Clutches	26
Break-a-Way Instructions	27
Pre Storage Maintenance	27
Torque Settings for Fasteners	28
Gearbox Maintenance	29
T-Box Disassembly and Assembly	30
Gearbox Disassembly and Assembly	32

SAFETY

There are obvious and potential hazards in the operation of this mower. REMEMBER! This machine is often operated in rough terrain conditions and brush up to 2" (50mm) diameter. The blades of this mower can propel objects for a great distance at very high speeds. Serious injury or even death may occur unless care is taken to ensure the safety of the operator, bystanders or passersby in the area.

KEEP CLEAR

Before attempting to operate this machine the owner and the operator should read, understand and heed the following information. Serious injury or death may occur if the safety advice given here is ignored. In addition to this safety advice, good 'common sense' will go a long way towards avoiding hazardous situations and reduce the risk of danger.

DANGER



Rotary mowers are capable under adverse conditions of throwing objects great distances (100 yards or more) and causing serious injury or death. STOP MOWING IF PASSERSBY ARE WITHIN 100 YARDS (91 metres) unless:

- Front and rear deflectors, chain guards or bands are fitted and are in good workable condition.
- Mower sections or wings are running close to, and parallel to, the ground without exposed blades.
- Passersby are outside the existing thrown-object zone.
- All areas have been thoroughly inspected and foreign materials such as rocks, cans, glass and general 'risk' debris have been removed.

NOTE: Where grass and weeds are high enough to obscure debris that could be struck by the blades, the area should be inspected and debris removed, mowed at an intermediate height, and re-inspected closely to remove any remaining debris and mowed again at the desired final height. *(In addition to the safety aspect of this procedure it will also reduce wear and tear on the mower drivetrain, spread cut materials better, eliminate 'streaking' and make the final cut more uniform).*

DANGER



The Chain Guards, Bands, Deflectors, Driveline Shields and Gearbox Shields should be used and maintained in good working condition at all times. They should be carefully inspected daily for missing or broken cable, chain links, shields or guards. Missing, broken or worn items must be replaced before attempting to use the machine to reduce the possibility of injury from thrown objects or entanglement.

WARNING



Extreme care should be taken when operating near loose objects such as gravel, rocks, wire and other debris. Foreign objects should be removed from the work site or avoided to prevent machine damage and/or bodily injury or even death.

DANGER



The rotating parts of this machine have been designed and tested for rugged use. However, they could fail upon impact with heavy solid objects such as steel guardrails and concrete abutments. Such impact could cause the broken objects to be thrown outward at very high velocities. To reduce the possibility of property damage, serious injuries, or even death, never allow the cutting blades to contact such objects.

WARNING The operator and all support personnel should wear 'hard hats', 'safety shoes' and 'safety glasses' at all times for protection from injury by falling objects and items thrown by the machine.



DANGER Operate the mower only with a tractor equipped with an approved 'roll over protection system (ROPS). Always wear your seat belt. Serious injury or even death could result from falling off the tractor – particularly during a turnover when the operator could be pinned under the ROPS or the Tractor.



WARNING Before leaving the tractor seat always engage the brake and/or set the tractor transmission in parking gear. Disengage the PTO, stop the engine, remove the key and wait for all moving parts to stop. Place the tractor shift lever into a low range or parking gear to prevent the tractor from rolling. Never mount or dismount a moving tractor. Operate the tractor controls from the tractor seat only.



WARNING Many varied objects such as wire, cable, rope or chains can become entangled in the operating parts of mower head. These items could then swing outside the housing at greater velocities than the blades. Such a situation is extremely hazardous. Inspect the cutting area for any such objects and remove prior to mowing. Never allow the cutting blades to contact such items.



DANGER Be particularly careful in transport. Turn curves or go up hills only at a low speed and at a gradual steering angle. Ensure that at least 20% of the tractor's weight is on the front wheels to maintain safe steering. Slow down on rough or uneven surfaces.



WARNING Ensure that all necessary signs are correctly displayed, and clearly visible, when working or transporting on or near a public highway. (*Contact your Local Highway Authority to ensure you are fully conversant with your responsibilities on this subject*). Use flashing warning lights when working or transporting on or near a public highway to indicate to other road users a potential hazard. Always abide by local traffic regulations.



WARNING Ensure all moving parts of the machine are regularly inspected for wear and replaced with authorised service parts if an excessive amount of wear is present.



WARNING Ensure the machine is regularly inspected for loose fasteners, worn or broken parts and loose or leaky fittings. Ensure all pins are fitted with cotter pins and washers. Serious injury can result from failure to maintain this machine in good working order.



DANGER

Never leave the machine in the raised transport position – the machine could fall inadvertently and cause injury or death to anyone who might be under the machine.

**DANGER**

Never clean or adjust PTO driven equipment with the tractor engine running. Kill the engine and pocket the key before attempting any maintenance on the machine.

**DANGER**

Never allow riders on either the tractor or the mower - falling off can kill.

**DANGER**

Never allow children to operate, ride on, or come close to the mower or the tractor.

**DANGER**

Never work under the mower deck, framework or any raised component unless the mower has been securely supported and blocked using suitable substantial items to prevent sudden or inadvertent falling which could cause serious injury or even death.

**WARNING**

Never operate the tractor and mower until you have read, and fully understood, the Operation Manual and are conversant with all the safety instructions stated here. Ensure you read all safety messages found on both the tractor and the mower.

**WARNING**

Ensure you maintain all safety decals in good readable condition. If a decal should for any reason become illegible order a replacement immediately before permitting the machine to be used.

**DANGER**

Never run a tractor engine in a closed building without adequate ventilation. The exhaust fumes can be hazardous to your health.



DANGER Ensure that a PTO shield is installed when using PTO-driven equipment and always replace the PTO shield if damaged.



CAUTION PROLONGED EXPOSURE TO LOUD NOISE MAY CAUSE PERMANENT HEARING LOSS ! Tractors with or without mowers attached can often be noisy enough to cause permanent or partial hearing loss. We recommend that hearing protection be worn at all times when the noise level experienced in the Operator's position exceeds 80db. Noise in excess of 85db on a long term basis can cause permanent total hearing loss. Where the tractor is fitted with a 'quiet cab' it is recommended that the windows are kept closed at all times whilst operating this machine.



In addition to the safety messages stated here the machine is fitted with warning decals that are designed to bring to the attention of the operator the potential dangers that exist whilst using the machine. However, these cannot replace correct proper training and total awareness of all the dangers involved in using a machine of this type, and the nature of the work it does. **BE ALERT, PAY ATTENTION – SOMEONE'S LIFE MAY BE AT STAKE !**

WHEN THIS SYMBOL IS DISPLAYED:



- **BE ALERT**
- **PAY ATTENTION**
- **SOMEONE'S LIFE IS AT STAKE**

SAFETY – Decal locations

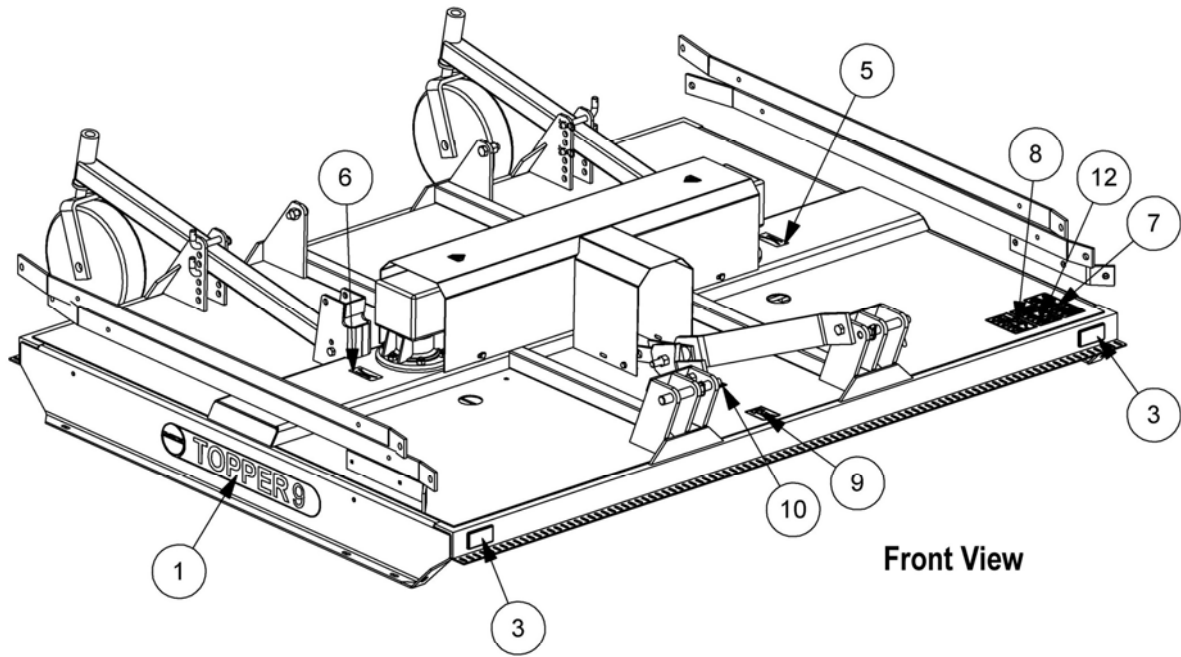

Front View

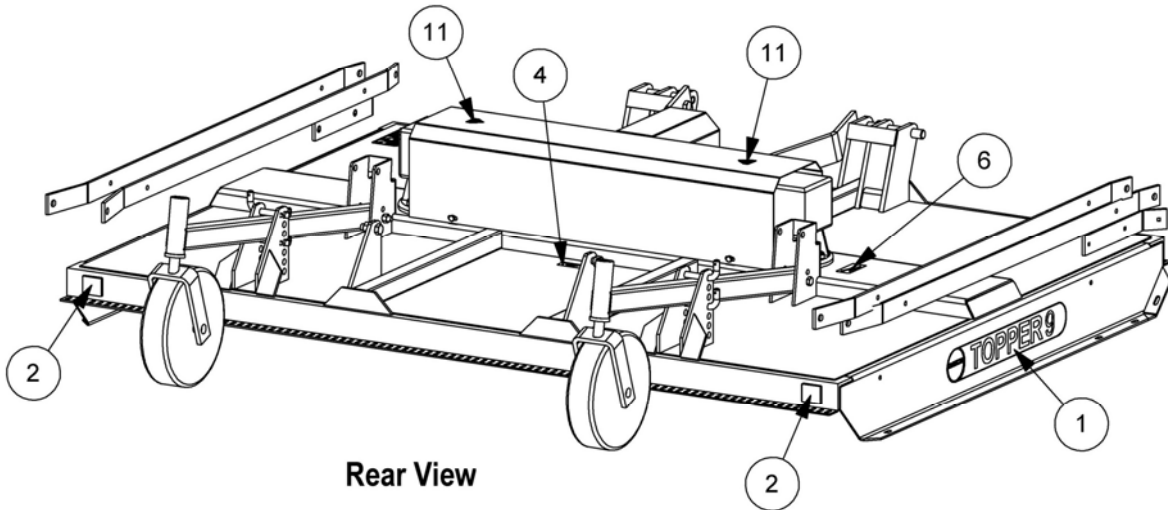

Rear View

REF.	PART No.	QTY	TYPE	DESCRIPTION
1	1290837	2	BRANDING	TOPPER 9
2	7560093	2	VISUAL SAFETY	RED REFLECTOR
3	7560155	2	VISUAL SAFETY	YELLOW REFLECTOR
4	D132	1	INSTRUCTION	BLADE TIMING
5	D137	1	INSTRUCTION	CCW BLADE ROTATION
6	D138	1	INSTRUCTION	CW BLADE ROTATION
7	09.821.29	1	WARNING	COMBINED EURODECAL
8	09.821.34	1	WARNING	COMBINED EURODECAL
9	09.811.04	1	INSTRUCTION	540 MAX ACW
10	00763613	1	INSTRUCTION	SLIP CLUTCH ADJUSTMENT
11	09.810.03	2	INSTRUCTION	GREASE 100 HRS
12	09.821.30	1	WARNING	EURODECAL ROTARY

MACHINE DECALS



1. Part Number 1290837

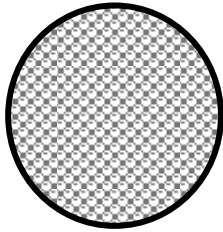

2. Part Number 7560093

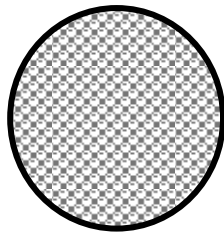

3. Part Number 7560155



4. Part Number D132

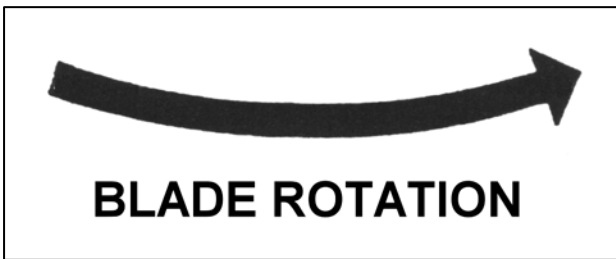

5. Part Number D137

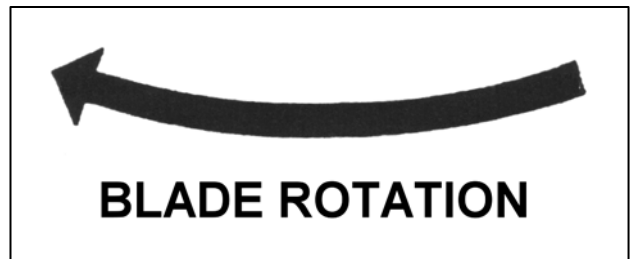

6. Part Number D138



7. Part Number 09.821.29



8. Part Number 09.821.34



9. Part Number 09.811.04

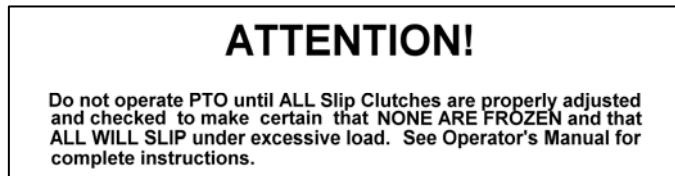

10. Part Number 00763613



11. Part Number 09.810.03



12. Part Number 09.821.30

INTRODUCTION

This Rotary Mower is designed with care and built with quality materials by skilled workers. Proper assembly, maintenance and operating practices, as described in this manual, will help the owner/operator get years of satisfactory service from the machine.

The purpose of this manual is to familiarise and instruct. The Assembly Section instructs the owner/operator in the correct assembly of the Mower using standard and optional equipment. The Parts Section is designed to familiarise the owner/operator with replaceable parts on the Mower. This section provides exploded assembly drawings of each mower component illustrating each piece and the corresponding part number.

Careful use, timely service and the fitting of Genuine Parts will save extensive repairs and costly downtime. The Operation and Maintenance Sections of the manual train the owner/operator how to work the Mower correctly and attend to appropriate maintenance tasks. The Trouble Shooting Guide helps diagnose difficulties with the Mower and offers solutions to the problems.

Safety is of primary importance to the owner/operator and to the manufacturer. The first section of this manual includes a list of Safety Messages that, if followed, will help protect the operator and bystanders from injury or death. Many of these messages will be repeated throughout the manual. The owner/operator/dealer should know these messages before attempting assembly and to be aware of the hazards associated with the operation of this machine during assembly, use and maintenance.

INTRODUCTION

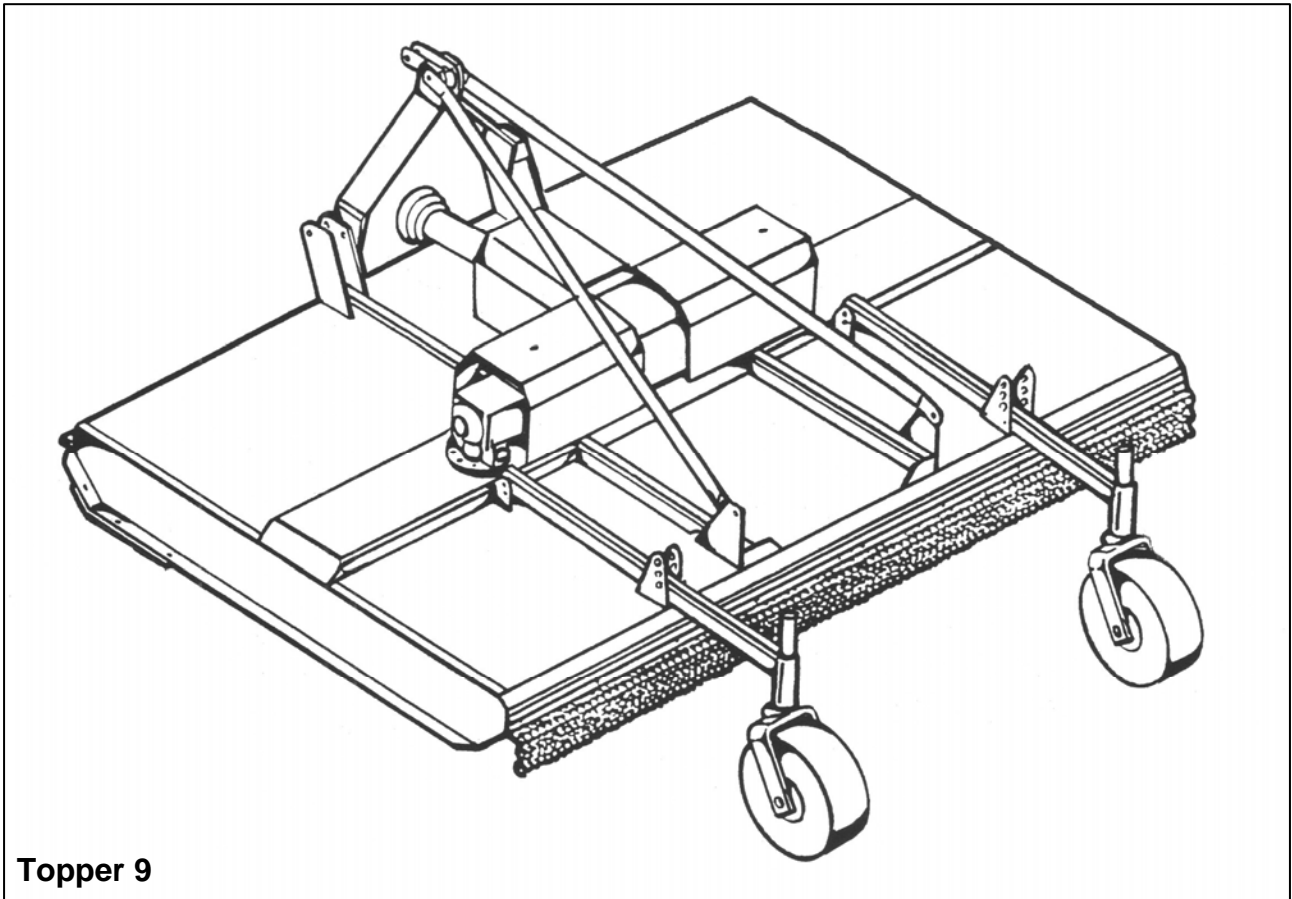

Topper 9

These rugged Mowers are designed for medium-duty work. They can mow pastures, cut brush up to 2" (50 mm) in diameter, and control grass and weeds on highways or industrial sites.



DANGER For Non-Agricultural use, OSHA, ASAE, SAE and ANSI standards require the use of Chain Guards, Deflectors or Solid Skirts at all times. The Mower manufacturer strongly recommends the use of Chain Guards for Agricultural purposes to reduce the risk of property damage, serious bodily injury or even death from objects thrown out by, or contact with, the Cutting Blades.

The 9' Lift Type machine requires a minimum of 50HP (37kW) with adequate front end weight.



WARNING At least 20% of the tractor's weight must be on the front tyres with the mower lifted to provide adequate traction for safe steering under good conditions. Slow down on hills, rough terrain, and curves.

NOTE: Where the terms 'Front', 'Rear', 'Left' and 'Right', are used in this manual it applies to view the operator has from the normal operating position on the tractor.

ASSEMBLY SECTION

The Topper 9 Mower will attach to most tractors with Cat. II and Cat. II Quick Hitch. The Topper 9 requires a tractor with 540-rpm PTO with a minimum of 50 HP (37kW).

DEALER SET-UP INSTRUCTIONS

Assembly of this Mower is the responsibility of the Dealer. The Mower should be delivered to the Owner completely assembled, lubricated, and adjusted for normal cutting conditions.

Set up Mower as received from the factory with these instructions. Open parts box and layout all the parts to make location easy. Refer to the parts lists and exploded view drawings for more details.

This Mower is shipped partially assembled. Assembly will be easier if components are aligned and loosely assembled before tightening hardware.

CAUTION Always use personal protection devices such as eye, ear, and feet protection during assembly.



'A' FRAME ASSEMBLY

- Insert bolt M20 x 55 (4) into lower end of each 'A' Frame half (1) and fasten with locknut (5).
- Align Link (2) between 'A' Frame halves (1) and Braces (3) with hole at top and retain with Bolt (6) and Locknut (4).
- Attach Braces (3) to rear lugs on the mainframe with Bolts M20 x 55 (4) and Locknuts (5).

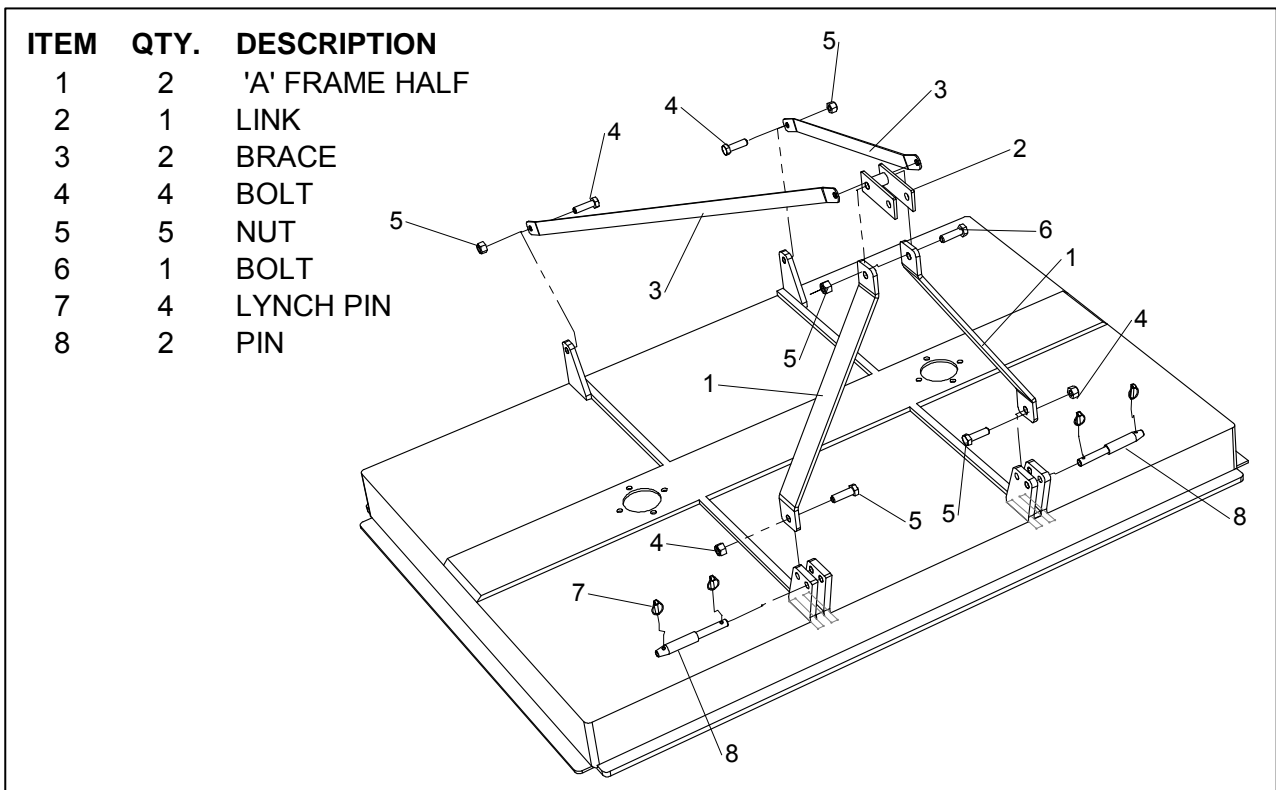

DRIVELINE ATTACHMENT

Before starting assembly of the Driveline ensure that all paint, dirt and grease are removed from the Gearbox Shaft (1). To ease assembly apply a light coat of grease to splines and assemble. **DO NOT ASSEMBLE A DRIVELINE WITHOUT A SHIELD.**

- Attach the slip clutch end of the driveline to the gearbox input shaft (1) securely. *(Ensure the Slip Clutch is fully located onto the input shaft splines).*
- Tighten locknuts (2) alternately until they have reached the correct torque. *(Refer to the Torque Chart in the Maintenance Section for correct setting).*
- RE-FIT ALL FIXED GUARDING

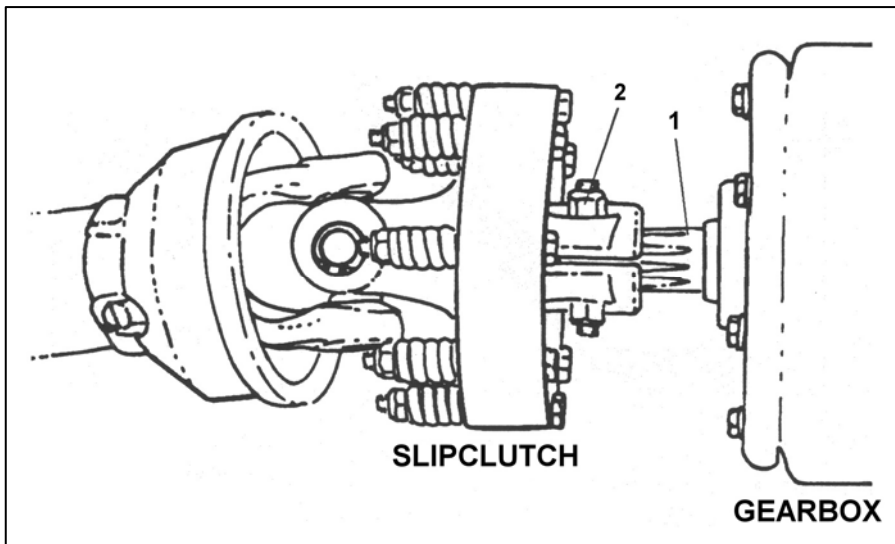

OPERATION SECTION

The safe operation of this machine is the responsibility of the operator. The operator should be familiar with the machine, the tractor, and all safety practices before attempting to start operation. This Mower is designed primarily for weed and grass control. It is equipped with updraft blades. The recommended cutting speed for most conditions is from 2 – 5 mph (3 to 8 km/h). Always operate the tractor at the recommended PTO speed.

IMPORTANT:

To avoid damage to cutter, re-torque all bolts after the first 10 hours of operation.
Re-torque blade carrier retaining nut on gearbox lower shaft to 450 ft. lbs (610 Nm).

MOWER PREPARATION

LIFT TYPE:

The Category II Hitch, standard on the 96" Mower requires no adaptors to attach to a tractor with Category II, 3-Point Hitch. To attach to Category I Hitch, optional pins must be ordered and Tractor Lift Arms are installed between lugs on mainframe. The Tractor Lift Arms are attached to the Hitch Pins.

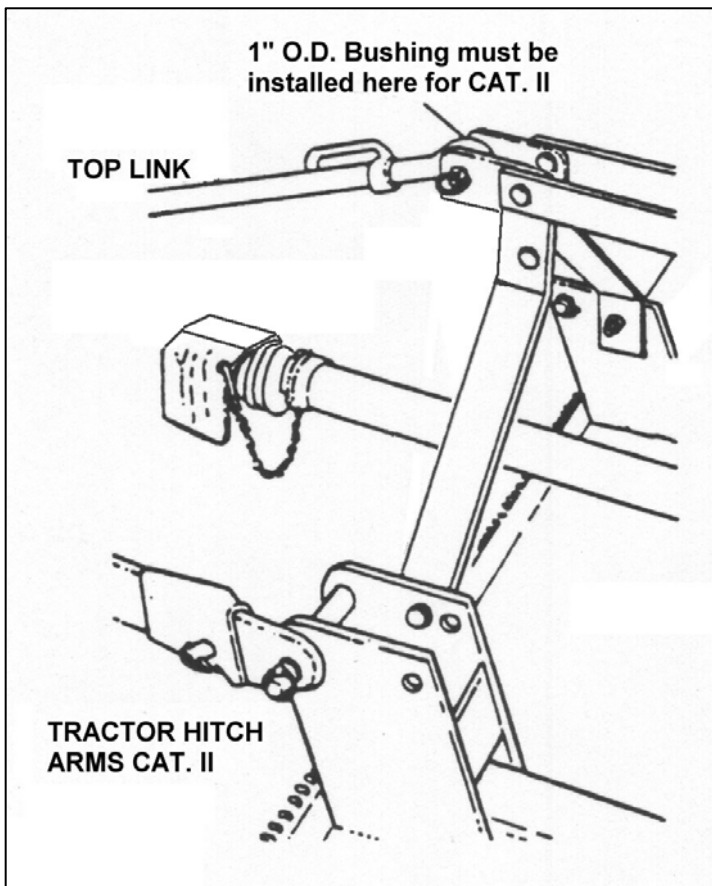

TRACTOR PREPARATION

Ballast

WARNING Do not operate with less than 20% of the tractor's gross unballasted mass on the front wheels with the Mower in the transport position.



Wheel Spacing

Tractor wheel spacing should be increased when working on inclines or rough ground to reduce the possibility of tipping.

Stabiliser Bars or Sway Blocks

Use Stabiliser Bars or Sway Blocks to prevent side sway of the Mower.

Draft Links

The linkage to the Lower Draft Links should be set in the 'float' position, allowing the unit to follow the contour of the terrain.

Drawbar

Shorten or remove the tractor Drawbar so it will not interfere with the up and down movement of the Mower.

WARNING Do not get, or allow others, between the Tractor and the Mower when the engine is running. Always kill the engine, apply handbrake, engage the tractor in gear, and pocket the key before attempting to work between tractor's and machines.



Attaching Mower To Tractor – Lift Type

- Back the Tractor up to the Mower so that the lower Draft Arms are in alignment with the Mower lower Lift Pins.
- Stop engine, lock the brakes or place the Tractor in park.
- Connect the Tractor and Stabiliser Bars to the lower Lift Pins.
- Adjust the Top Link so it will pin to the top holes in the A-Frame.

CUTTING HEIGHT ADJUSTMENT

WARNING Avoid personal injury ! Ensure the engine is switched off and the key removed. WAIT UNTIL BLADES HAVE STOPPED TURNING before dismounting to make adjustments.



IMPORTANT: Avoid very low cutting heights – striking the ground with blades causes the most damaging shock waves a Mower can encounter and will cause damage to the Mower and drive.

To achieve maximum cutting efficiency, and provide the most uniform cut, the Mower should be operated with the rear of the Mower slightly higher, $\frac{1}{2}$ " – 1" (12.5 – 25 mm), than the front.

CUTTING HEIGHT ADJUSTMENT – LIFT TYPE

- Place Tractor and Mower on a level surface.
- Raise the Mower to approximate desired cutting height with the Tractor hydraulic lift control lever.
- Loosen or remove locating pins on gauge wheel frame tubes. Insert top pin at desired cutting height, insert bottom pin in hole, which clears tube, and insert R-Clip to retain.
- Lower the Mower slowly until the rear of the Mower is $\frac{1}{2}$ " – 1" (12.5 – 25mm) higher than the front. Position the adjustable stop on the tractor lift quadrant against the lift control lever so the Mower can be returned to the same height.
- Adjust the length of the top link so that when lifting the Mower the front of the Mower will raise 2" - 2½" (50-62.5mm) before the gauge wheels leave the ground. (*This will permit the flexible hitch to pivot and allow the Mower to follow the contours on uneven ground*).
- Level the Mower side to side with the tractor lower link adjustment.

IMPORTANT: When raising the Mower to transport height ensure there is clearance between the Mower and the driveline – DAMAGE WILL RESULT IF THE DRIVELINE HITS THE DECK OF THE MOWER.

STARTING AND STOPPING MOWER

Power for operating the Mower is supplied from tractor PTO. Refer to your Tractor Manual for instructions regarding engaging and disengaging of the PTO.

ALWAYS engage the PTO at low engine rpm.

ALWAYS operate at the recommended PTO speed.

LEARN how to stop the Tractor and Mower quickly and safely in case of emergency.

IMPORTANT: Stop the Mower and Tractor immediately upon striking an obstruction. Inspect the Mower for damage and repair before resuming operation. DO NOT DISENGAGE PTO WHEN ENGINE IS AT FULL PTO RPM – always idle engine before disengaging the PTO.

WARNING Avoid personal injury. When attempting to stop a tractor that does not have live PTO, the momentum created by the blade carrier of a rotary mower can cause the tractor to be pushed forward. DO NOT operate this Mower unless tractor has live or independent PTO.



To commence operation, reduce engine speed and engage the tractor PTO. Before starting to cut, gradually increase the engine speed to develop full PTO speed.

DANGER Chain Guards must be installed if operating with people or livestock in the area or close to highways or buildings and in all non-agricultural operations.



Enter the area to be cut with the Mower operating at PTO speed and, if it becomes necessary to temporarily regulate engine speed during operation, increase or decrease the throttle gradually.

CUTTING SPEED

Proper ground speed for cutting will depend upon the height, type, and density of material to be cut.

Normally, ground speed will range from 2 to 5 mph (3 to 8 km /h). Tall dense material should be cut at low speed while thin medium height material can be cut at a faster ground speed.

CUTTING TIPS:

Always operate PTO at recommended rpm when cutting – this is necessary to maintain proper blade speed and to produce a clean cut.

Under certain conditions tractor tyres may roll some grasses down and prevent them from being cut at the same height as the surrounding area. When this occurs, reduce the tractor ground speed, but maintain PTO rpm. The lower speed will permit grasses to, at least, partially rebound and be cut. Taking a partial cut and/or reversing the direction of travel may also produce a cleaner cut.

As often as possible, stop mowing when other people are passing by. Although the Mower is shielded to prevent objects from being thrown out by the blades, no one device is 100% effective. The safest possible course is the only sensible approach to the problem of endangering a passerby.

WARNING Avoid personal injury. Take the time to pick up all rocks and other debris in the work area before attempting to mow. Enter new areas carefully and cut material higher the first time to allow the mower to clear unseen objects. Never assume an area is clear – always check, it may save injury or damage to your machine.



Extremely tall grass should be cut twice. Raise the Mower and cut twice to the desired height. Cut the second time to the desired height at 90 degrees to the first pass.

Remember that sharp blades will produce a cleaner cut and will use less power.

Before cutting, analyze the area to determine the best cutting procedure. Consider the height and type of material as well as the terrain type – hilly, level, or rough.

DETACHING AND STORING YOUR MOWER

- Lower the Mower to the ground and park the Tractor with brakes on, kill the engine, remove and pocket the key.
- Wait until the PTO has stopped rotating before dismounting the Tractor.
- Disconnect the Driveline from the Tractor PTO.
- Disconnect the Top Link and the Lower Lift Links from the Mower.
- Always reinstall the Master Shield over the Tractor PTO shaft - this shield should always remain in place and should only be removed to enable the connection or disconnection of the Driveline.

DRIVELINE LENGTH CHECK PROCEDURE

WARNING A loose shaft could slip off and result in personal injury or damage to the Mower. When attaching PTO yoke to tractor PTO shaft, it is important that the spring-activated locking collar slides freely and locking balls are seated in the groove on the PTO shaft.



WARNING Before operating the Mower, check to ensure the Driveline will not 'bottom out' or become disengaged.



- Set parking brake, kill engine, remove and pocket the key.
- Disengage the Driveline from the Tractor PTO shaft.
- Slide the Driveline together until it 'bottoms out' solidly.
- Apply coloured tape to the Inner Shield $\frac{1}{8}$ " (3mm) from the end of the Outer Shield (see diagram below)

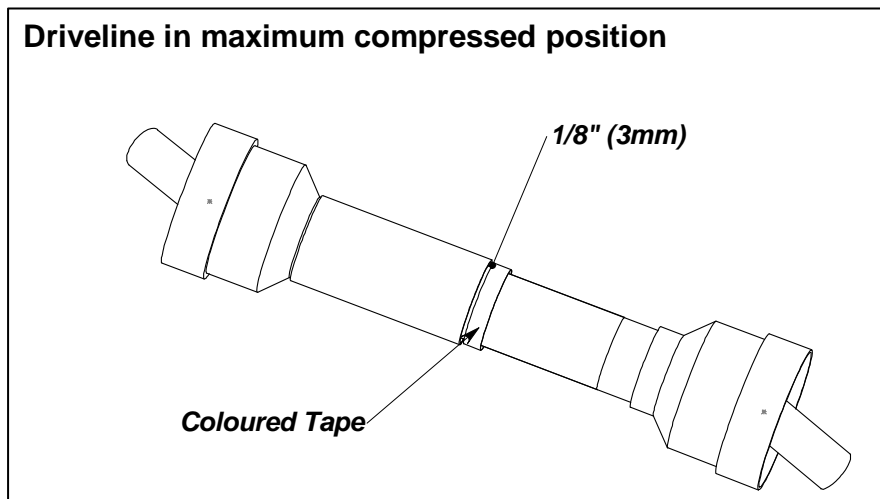

- Re-attach the Driveline to the PTO shaft, ensuring balls are correctly seated in the groove on shaft.
- Raise Mower to full transport height or until Driveline just touches deck at front. If distance between coloured tape and outer shield is $1\frac{5}{8}$ " (40mm) or less, drive tubes should be shortened (see diagram below).
- Always maintain $1\frac{5}{8}$ " (40mm) clearance when operating in the shortest working position. Shorten inner and outer guard tubes equally. Shorten inner and outer sliding profiles by the same amount that the shield tubes were shortened. Round off all sharp edges and remove burrs. Grease sliding profiles (see diagram below).

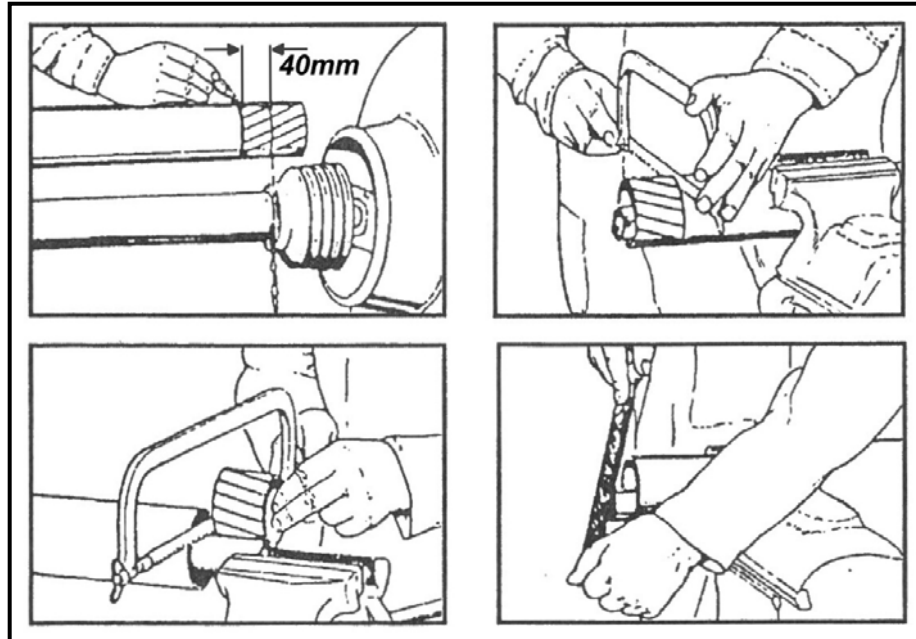

- Lower Mower to lowest position possible. Check distance from coloured tape to end of outer shield tube. Driveline tube engagement must always exceed 12" (300mm). If not consult your Dealer to obtain a longer Driveline.

TROUBLESHOOTING – GENERAL		
PROBLEM	POSSIBLE CAUSE	REMEDY
NOT CUTTING CLEAN	Blades dull. Blade rotation incorrect. Using straight blades. Carrier rpm too low. Mower not leveled. Tyres flattening grass. Ground speed too fast. Blades locked back. Blades riding up due to Blade Bolt wear. Blades bent up.	Sharpen or replace Blades. Use correct Blade carrier. Use Fan Blades in grass. Increase PTO to recommended rpm Adjust machine level - <i>in very heavy weeds set rear ½" -1" (12.5-25mm) higher than the front.</i> Increase tyre spread to 90" (2.25m). Reduce ground speed. Free Blades. Replace Blade Bolts. Replace Blades.
BREAKING BLADE BOLTS	Operating with loose Blade Bolts. Worn Blade Bolt.	Tighten Blade Bolts to 350 ft lb. (475 Nm) – <i>Right hand threads.</i> Replace Bolt.
CUTTING TOO HIGH	Blades bent up. Blade Carrier bent. Blades on upside down.	Replace Blades. Straighten or replace Blade Carrier. Turn Blades right side up and tighten.
MOWER VIBRATES	Blade locked back. Drivelines not phased. Blade broken. Blade Carrier bent. Blade Hub not properly seated on Shaft. New Blade matched with worn Blade.	Loosen locked Blade. Replace Driveline. Replace Blades in sets. Repair or replace Carrier. Remove Hub, check for wear and replace or seat properly - <i>Tighten Hub Bolts to 450 ft lb. (610Nm).</i> Replace Blades in sets.
MOWER WINDROWING	Cutting heavy material.	Raise Mower and reduce groundspeed.
FAST BLADE WEAR	Cutting in sandy or rocky conditions. Blades too soft.	Increase cutting height. Replace Blades; with hardened, high-quality, Rhino Blades from the manufacturer.
BLADE BOLTS WORKING LOOSE	Bolts not tightened. Bolt hole elongated or oversized. Locknut worn out.	Tighten Bolts to 350 ft lb. (475 Nm.) Replace Blade Carrier. Replace Locknut.

TROUBLESHOOTING – PTO SHAFTS		
PROBLEM	POSSIBLE CAUSE	REMEDY
BROKEN CROSS OR CUPS	Load too high for joint.	Use protective device with joint. Check joint angles and phasing. Slow down or raise Mower. Check Slip Clutch is not frozen or seized. <i>(See Clutch Maintenance)</i> .
END GALLING OF CROSS AND CUPS	Speed too high during turns.	Reduce PTO speed.
NEEDLE ROLLERS HAVE BRINELLED INTO CUP AND CROSS	Load too high for joint.	Check for small joint angles. Check joint angles and phasing. Check Slip Clutch is not frozen or seized. <i>(See Clutch Maintenance)</i> .
SHAFT OR TUBE TWISTED	Over-loaded.	Replace part and then slow down or raise Mower. Use protective device. Check Slip Clutch is not frozen or seized. <i>(See Clutch Maintenance)</i> .
TUBE BROKEN IN WELDED SEAM	Over-loaded.	Replace part. Check Slip Clutch is not frozen or seized. <i>(See Clutch Maintenance)</i> .
YOKE BROKEN AT EAR TIP	Over-loaded.	Replace part. Check Slip Clutch is not frozen or seized. <i>(See Clutch Maintenance)</i> .
DRIVELINE INTEGRAL SHIELDS RATTLING OR NOT TURNING FREELY	Integral Shields deformed. Nylon Bearing worn.	Replace Shield. Replace Nylon Bearing.

TROUBLESHOOTING – GEARBOX		
PROBLEM	POSSIBLE CAUSE	REMEDY
NOISY GEARBOX	Improper backlash. Rough Gears. Worn Bearings	Refer to your Dealer. Run in or change Gears. Replace Bearings.
SLIP CLUTCH SLIPPING EXCESSIVELY	Excessive load. Springs weak. Improper adjustment. Too much power for Slip Clutch. Friction Facings worn. Oil on Facings. Friction Facings glazed.	Reduce speed and/or raise Mower. Replace Springs. Re-adjust Slip Clutch. Reduce ground speed and material intake. Replace Facings. Replace Facings. Clean with emery cloth.

OIL BLOWING OUT VENT PLUG	Flat bottomed Vent Plug or shallow cavity Plug. Oil level too high.	Replace with proper Vent Plug, cavity in Oil Plug should be approximately $\frac{5}{8}$ " (16mm). Lower Oil level to Plug.
GEARBOX LEAKING	<p>Damaged Oil Seal.</p> <p>No Oil Seal.</p> <p>Oil too light.</p> <p>Bent Shaft.</p> <p>Oil Seal race rough.</p> <p>Oil Seal installed incorrectly.</p> <p>Oil Seal not sealing in housing.</p> <p>Bearings loose.</p> <p>Vent Plug stopped up.</p> <p>Oil level too high.</p> <p>Gasket damaged.</p> <p>Bolts loose.</p>	<p>Replace Seal.</p> <p>Install Oil Seal.</p> <p>Use EP90.</p> <p>Replace Oil Seal and Shaft.</p> <p>Replace Shaft or repair race.</p> <p>Replace Seal.</p> <p>Replace Seal or use sealant.</p> <p>Adjust Bearings.</p> <p>Open Vent Plug.</p> <p>Drain Oil to correct level.</p> <p>Replace Gasket.</p> <p>Tighten Bolts.</p>

MAINTENANCE

Before operating your Rotary Mower ensure it is properly lubricated and thoroughly inspected. The time and effort is required to regularly lubricate and maintain your Mower is minimal, but necessary, to provide long life and trouble free operation of your machine.

WARNING Always disengage the PTO before raising the Mower for transporting or making adjustments.



LUBRICATION INFORMATION

Do not allow excess grease collect on or around parts, particularly when operating in sandy areas. The illustration below shows the positions of the Mower Lubrication Points and gives details of the frequency at which these points should be lubricated under normal working conditions – severe or unusual conditions may require more frequent lubrication. Use SAE multi-purpose, lithium type grease for all greasing locations indicated below. Ensure the fitting is thoroughly cleaned before applying lubricant to avoid contamination by dirt or grit.

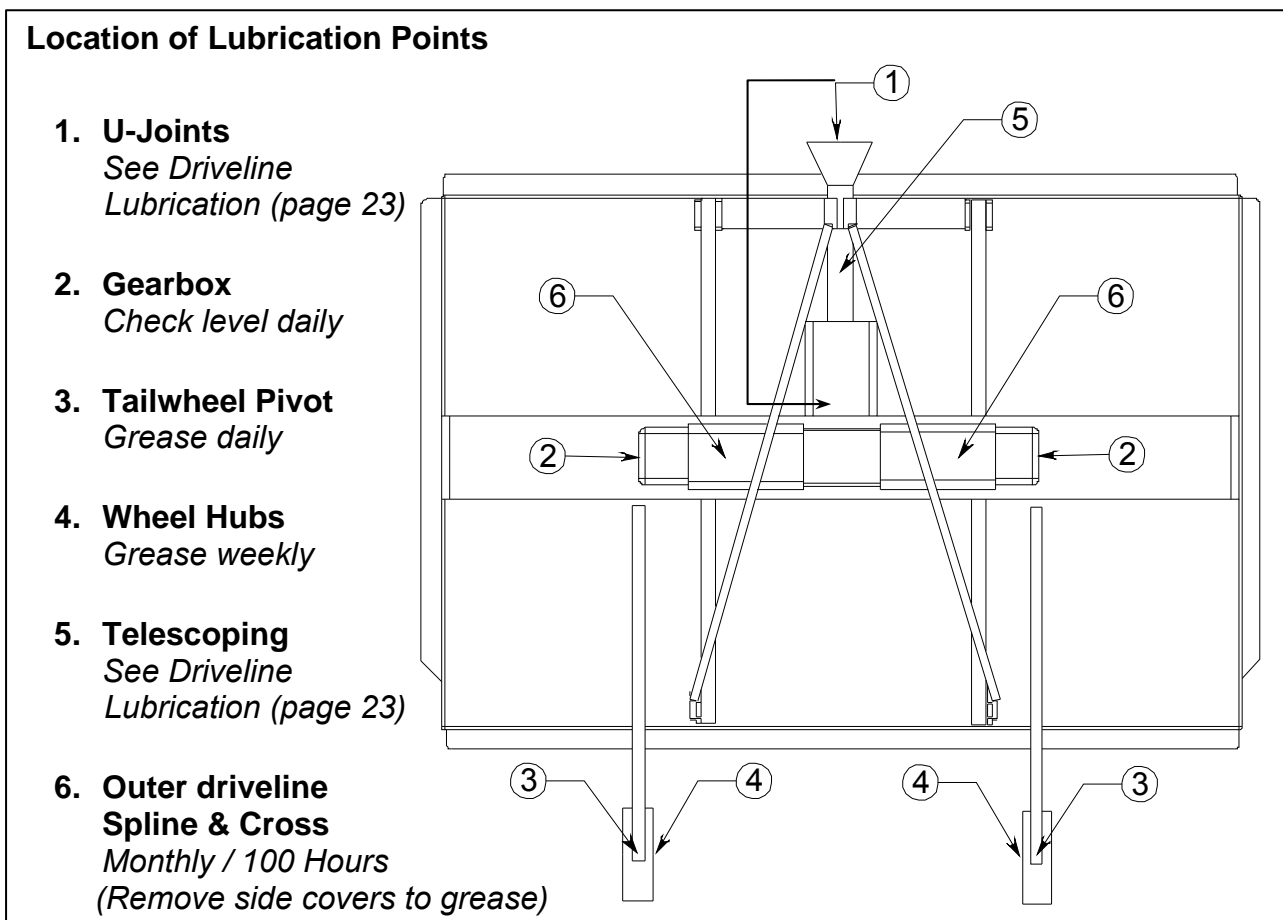

NOTE: Failure to maintain proper lubrication will result in damage to U-Joints, gearbox and/or Driveshaft.

GEARBOX

The Gearbox has been filled with lubricant to the Test Plug Level prior to shipment. However as a precaution you should check the oil level at the Test Plug before operating the Mower and frequently thereafter (*Daily during normal use*).

The Gearbox should not require additional lubricant unless the box is cracked or a seal is leaking. It is recommended that the oil level plug be removed every 8 to 10 hours of normal operation and oil added until it runs out of the Test Plug hole. The Test Plug is located on the rear of the Gearbox and the Filler Plug is located on the top of the Gearbox. (See diagram below).

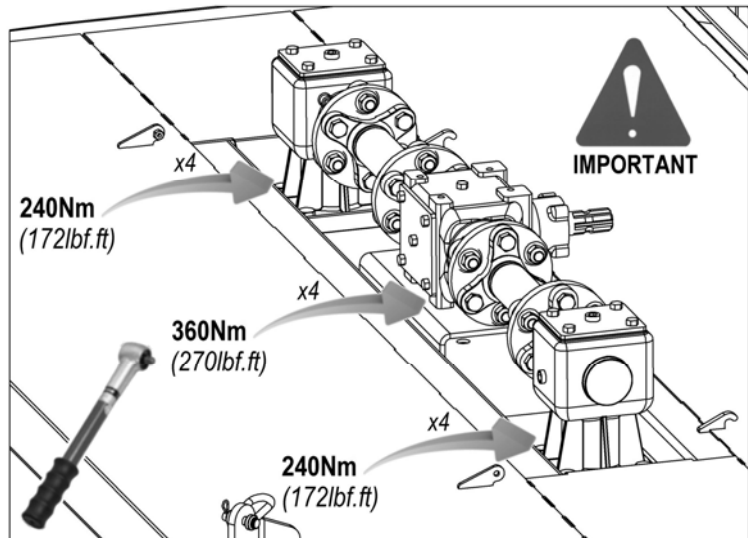
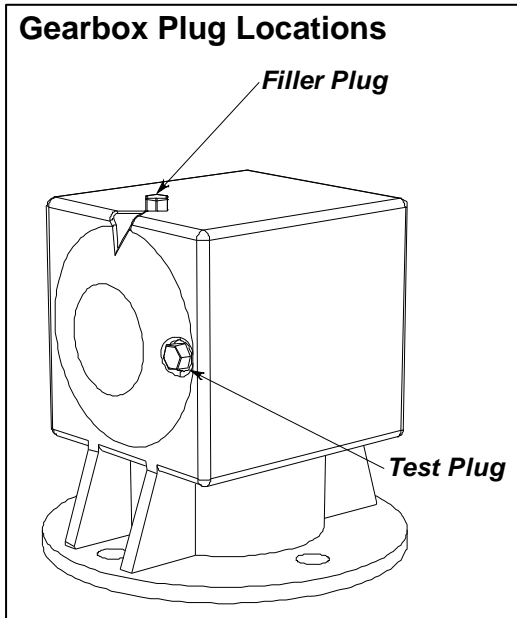

Torque settings for gearbox mounting bolts
– check on a regular basis and re-torque if required

Recommended lubricants for the Gearbox are: Exxon – Spartan EP220, Mobil HD 80W90, or equivalent. Required lubricant is a SAE 90 or SAE 80W90 with EP additives for extreme pressure and temperature, with a API-GI-5 Service rating.

NOTE: Overfilling the Gearbox will result in pressure build up and cause Oil Seals to leak.

ATTENTION: If Gearbox suddenly starts making an unusual noise, stop immediately, check for leaks, and refill Gearbox as required.

TAIL WHEEL ASSEMBLY

Tail Wheel Bearings are pre-packed at the factory with heavy-duty bearing grease.

Grease Fittings are located in the Wheel Hub and Tail Wheel Beam to allow lubrication of these points (See diagram opposite)

Details of the frequency at which these points require greasing can be found on the previous page.

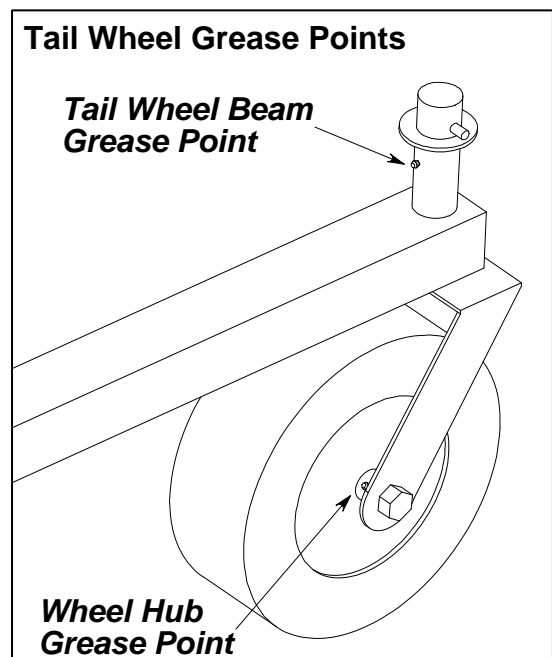

DRIVELINE LUBRICATION

Grease Fittings are located on the Cross Assembly of each U-Joint and on the telescoping tubes. Grease the U-Joint after every 8 hours of use. Do not force grease through the Needle Cup Assemblies. Grease the telescoping tubes after every 16 hours of use. On some PTO to Hitch connections, it may be necessary to cut a hole in the shields to facilitate alignment of the Grease Fittings for lubrication. Lubricate the shield bearings every 8 hours (see diagram below).

Refer also to Information sheet that was shipped attached to PTO shaft.

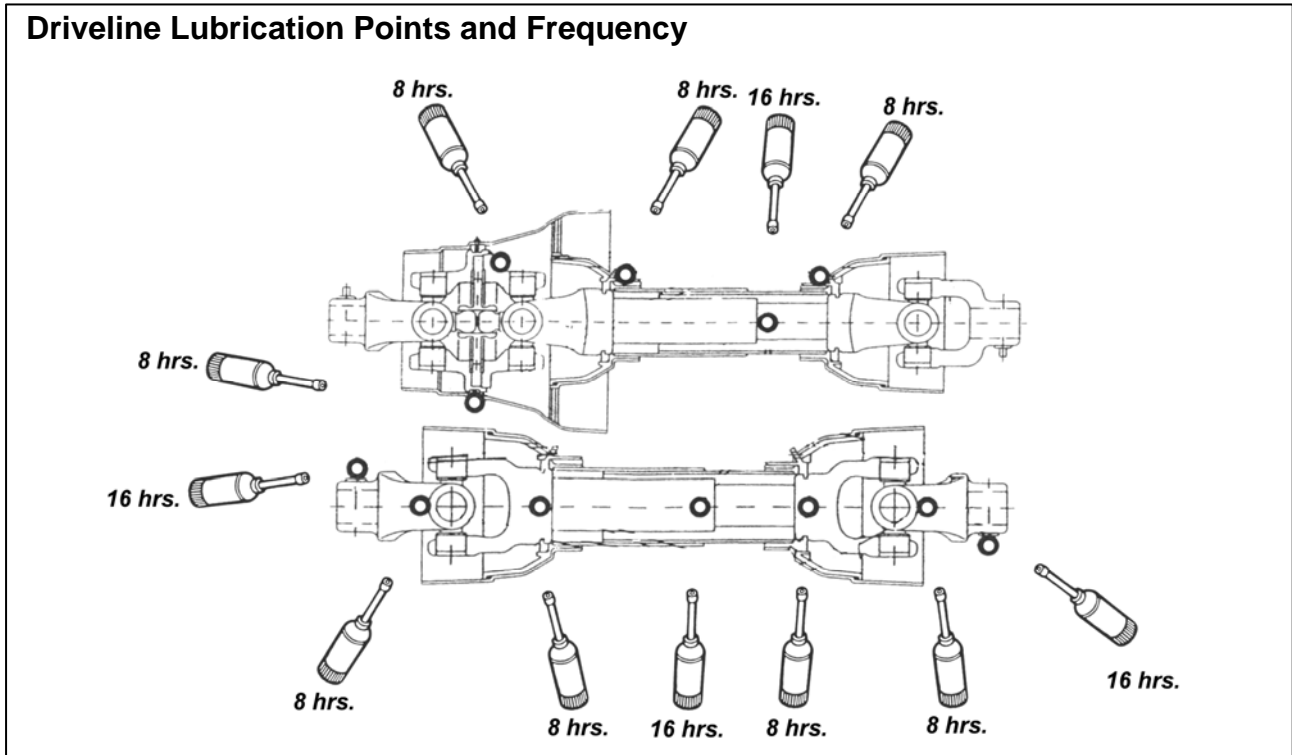

DRIVELINE SHIELD REMOVAL

The Driveline Integral Shields should not become dented or otherwise damaged. The Integral Shield Assembly has a Nylon Bearing at each end, which should turn freely, and will require lubricating after every 8 hours of use. To remove the Integral Shields for replacement or repair, turn the three Nylon Bolts through a $\frac{1}{4}$ turn in the Shield Slots of the Cone and Tube and remove them. Slip the Shield Cone Assembly off the inner section of the Driveline and install the new or repaired Shield on the Driveline. Place the split Nylon Bearing over the Driveline Housing against the Yoke and in the Bearing groove. Install shield over the Housing so the Nylon Bearing fits into the Shield Bearing retainer. Align a slot in the Shield Cone with one of the slots in the Shield. Put one of the Nylon Bolts back in through the aligned slot and turn until it is perpendicular to the slots. Replace the other two Nylon Bolts.

CAUTION Ensure that the Driveline Integral Shields are free to telescope and rotate around the Driveline without binding.



WARNING When attaching PTO yoke to tractor PTO shaft, it is important that the spring-activated locking collar slides freely and that the locking balls are seated in the groove on the PTO shaft. A loose shaft could slip off and result in personal injury or damage to your machine.



BLADE SERVICING

Blades should always be inspected prior to work each time you use the Mower to ensure they are in good working condition and correctly installed. Replace any Blade that is bent, excessively nicked, worn or otherwise damaged. Small nicks can be ground out when sharpening. If a Blade requires replacing, it is recommended that they be replaced in pairs in order to maintain balance.

IMPORTANT: When sharpening blades, grind each blade by the same amount to maintain balance. The difference in blade weights should not exceed 1 ounce (28gms). Unbalanced blades will cause excessive vibration, which can damage gearbox bearings. Vibration may also cause structural cracks in the Mower housing.

WARNING Use only Original Equipment Blades on this Mower. They are made of special-heat treated alloy steel. Substitute Blades may not meet the specifications required for this Mower and may fail in a hazardous manner that could cause injury.



BLADE SHARPENING

Always sharpen both blades at the same time to maintain balance. Follow the original sharpening pattern (see diagram below) and always sharpen blades by grinding. DO NOT heat and pound out edge or sharpen the blade to a razor edge, but leave a 1/16" (1.6mm) blunt edge. Do not sharpen the back side of the blade.

WARNING Avoid personal injury. Always block the Mower up to prevent it from falling when servicing the blades and/or carrier.

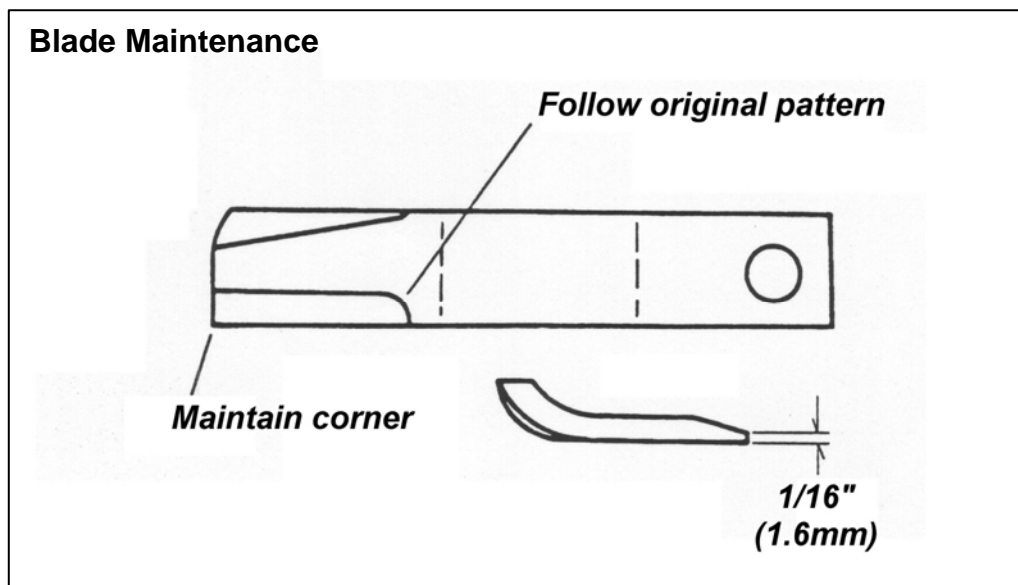

BLADE REMOVAL

To remove blades for sharpening or replacement, remove the cover plate on the deck of the Mower near the gearbox and remove the lock nut from the blade bolt. **NOTE:** *Inspect lock nut after removal and replace if threads are damaged. Always replace lock nut when replacing blade bolt.*

When installing or replacing blades ALWAYS check the blade bolt pivot diameter for wear and replace if it is worn more than $\frac{1}{4}$ " (6mm) at any point. Install blade bolts with 'unworn' portion of blade bearing area towards centre of carrier. Tighten lock nut to 350 ft.lbs. (475Nm).

WARNING Avoid personal injury. Blade and/or Blade Carrier removal should be done only with the Tractor engine shut off, key removed, in neutral, parking brake on, with the PTO disengaged and the Mower blocked in the raised position.



BLADE CARRIER REMOVAL

Remove cotter pin and loosen slotted nut on gearbox shaft. Loosen but do not remove the nut until the blade carrier is loosened. Use a suitable 2-jaw 'gear puller' to pull the carrier off the tapered gearbox shaft. If gear puller is not available a long bar can be utilized by inserting it through blade bolt access hole with the end against rotor bar. Strike opposite end of bar with a sledgehammer. Rotate blade carrier through 180 degrees and repeat process.

BLADE CARRIER INSTALLATION

Clean the splines on both the blade carrier and output shaft. Position carrier on the gearbox output shaft and install special washer and nut.

Tighten nut holding blade carrier to minimum 450 ft.lbs. (610Nm) strike the carrier near the hub several times with a heavy hammer to seat the hub. Use a suitable spacer over the nut to prevent damage to the nut and its thread. Retighten the nut to 450 ft.lbs. (610Nm). Install cotter pin and spread its ends.

IMPORTANT: Always rechecks gearbox output shaft slotted blade carrier retaining nut torque after a few hours of operation.

WARNING Avoid personal injury. Do not attempt to work under a Mower without suitable support blocks to keep the frame from falling.



ATTENTION !

Do not engage PTO or attempt to start mowing until ALL Slip Clutches are properly adjusted and checked to make certain that NONE ARE FROZEN and that ALL WILL SLIP under excessive load.
Refer to Operator's Section for complete details

EXTERNAL COIL SLIP CLUTCH DISK REPLACEMENT

TO DISASSEMBLE EXTERNAL COIL SPRING CLUTCH (*Refer to diagram 'A' below*)

- Remove two Attaching Bolts (6). Remove Clutch Assembly from shaft of Gearbox. Leave Driveline or Driveline Half attached to Clutch.
- Loosen eight Adjusting Bolts (1). LOOSEN EACH NUT HALF A TURN AT A TIME – NOT ALL AT ONCE. Continue in rotation until Nuts are loose. Remove these Bolts. Flange Yoke (9) will slide off.
- On the opposite side, Outer Flange (2) will slide off and allow Clutch Plate (3) to slide over notches on outside diameter of Clutch Body (5).
- Remove Plate with eight bolt holes (7). **Note: Bolts (1) go through these holes.**
- Remove the four Friction Disks (4) and discard. **DO NOT RE-USE.**

TO CLEAN AND INSPECT

- Inspect all components for rust, wear, or damage.
- Check Spacer (8) for scoring or excessive wear.
- Clean Clutch Plates and Drive Plates with a wire brush as required to remove any rust.

TO REASSEMBLE (*Refer to diagram 'A' below*)

- After all parts have been inspected, cleaned or replaced as necessary, replace components in reverse order to disassembly USING THE NEW, IMPROVED DISKS.
- Do not tighten the eight Adjusting Nuts and Bolts (1) until assembly is complete and ready for setting.

TO ADJUST (*Refer to diagram 'B' below*)

- To adjust Slip Clutch, tighten Bolts (1) until the Nut makes contact with Compression Spring (10).
- DO NOT tighten any one bolt completely, tighten in rotation to ensure equal pressure all the way around on Friction Disks and Drive Plates.
- Tighten each Nut one-half turn in rotation.
- Retighten each Nut one-half turn again and continue in this manner until Spring length measures 33mm ± 0.2mm.
- Re-assemble Clutch to Gearbox and tighten Bolts (6) securely.
- Should the Clutch slip too easily STOP IMMEDIATELY. Tighten each Adjusting Nut (1) NO MORE THAN ¼ TURN.

NEVER TIGHTEN SPRINGS TO A LENGTH OF LESS THAN 32.0 mm.

NOTE: EXCESSIVE SLIPPING WILL BURN UP DISKS AND SLIP CLUTCH TO THE POINT WHERE THE CLUTCH IS NOT REPAIRABLE. HOWEVER, EXCESSIVE TIGHTENING WILL PREVENT THE CLUTCH FROM SLIPPING AND CAN LEAD TO FAILURES OF DRIVETRAIN COMPONENTS WITH RESULTING DOWNTIME.

TO REPLACE SHIELDS

- Ensure that all Driveline Canopy Shields are in good repair and rotate freely on the Drivelines. Replace Bearings and/or Integral Shields if necessary.
- Re-install Gearbox Canopy Shields with their fixings and tighten securely.

**Spring Clutch Components and Adjustment Diagram
Machines to 04/19**

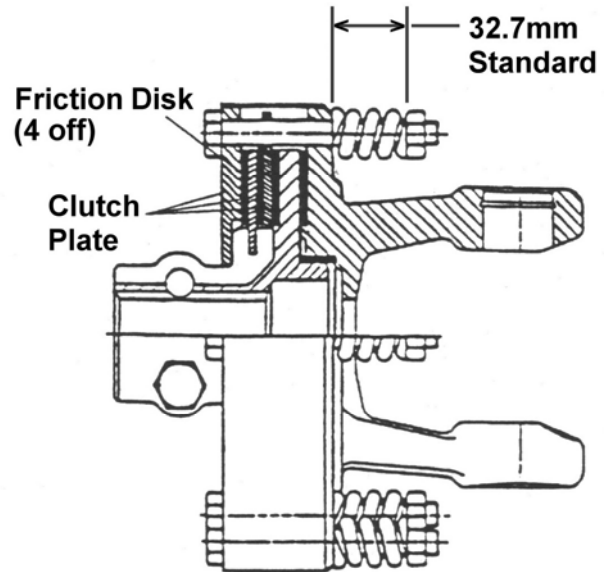
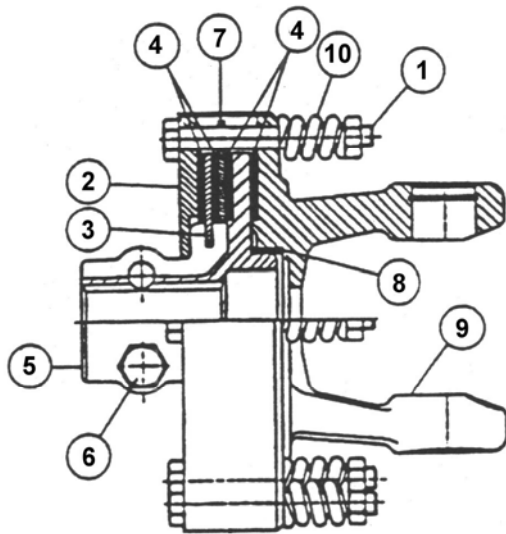

(A) SPRING CLUTCH

(B) SLIP CLUTCH ADJUSTMENT

Ref.	Qty.	Description
1	8	Nut and Bolt
2	1	Pressure Plate
3	1	Inner Plate
4	4	Clutch Lining
5	1	Clutch Body

Ref.	Qty.	Description
6	2	Bolt and Nut Set
7	1	Plate (with holes)
8	1	Spacer
9	1	Yoke-Clutch
10	8	Spring-Clutch

**Clutch Setting Diagram
Machines 04/19 onwards**

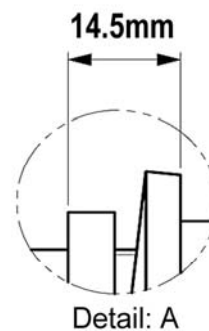
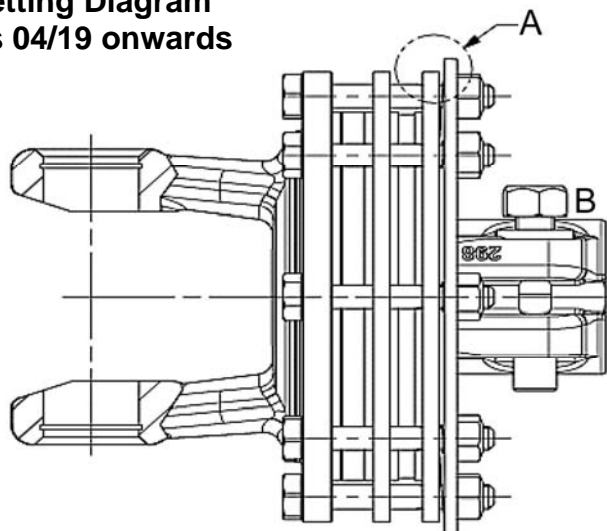

Nut 'B' : Torque **140-160 Nm**

SLIP CLUTCH PRECAUTIONS

If MOWER is stored outside for 30 DAYS or more and be exposed to rain or humid air, the CLUTCHES should be removed and STORED IN A DRY AREA.

However, if CLUTCHES are left outside for 30 days or more, ensure that you follow the BREAK-A-WAY INSTRUCTIONS stated below.

IMPORTANT !

It is extremely important to check for and FREE UP EVERY FROZEN CLUTCH in order to prevent overloading of the Drivetrain and possible failure of Drivetrain or Tractor components.

TO TEST FOR FROZEN CLUTCHES

- Mark a chalk line across Clutch Disks and Plates to indicate Clutch slip – *if the Clutch slips the lines would become mis-aligned.* – Refer to diagram on previous page: parts 3 & 5 should move in relation to parts 2, 7 & 9.
- With the Mower lifted off the ground, PTO engaged, and tractor at HALF THROTTLE, let the tractor clutch out rapidly. Stop tractor and check that the plates have slipped.
- If all Clutches slip and provide protection for the Drivetrain you are ready to begin Mowing (*providing all other normal maintenance has been carried out correctly and Guarding has been replaced*). If the Clutches fail to slip you will need to perform the following 'Break-a-way' procedure.

BREAK-A-WAY INSTRUCTIONS – *Machines stored outside for 30 days or more.*

- Before mowing, back off all Adjusting Nuts (1) until Nuts just touch Springs (10). Then, tighten Nuts one full turn uniformly - *½ turn each, then ½ turn each again.*
- Mark Plates and Disks - *as described in the previous section on Frozen Clutches.*
- With PTO engaged and the tractor running at HALF THROTTLE, let clutch out rapidly to 'pop' Slip Clutches loose. If all Slip Clutches slip (*as is necessary*), adjustment can now be made – *refer to 'Clutch Adjustment' in previous section for details.*

Providing all normal maintenance has been completed correctly and all Guarding has been replaced you are now ready to mow.

STORAGE

Your Rotary Mower represents an investment from which you should gain the greatest possible benefit. Therefore, when the season is over, the Mower should be thoroughly checked and prepared for storage. Time spent on this task now will not only ensure that your machine is stored in prime condition, but will also reduce the amount of work required to put it back into operation for the next season.

The following are suggested storage procedures:

- Thoroughly clean the Mower.
- Lubricate the Mower (*refer to Lubrication in the Maintenance Section*).
- Tighten all Bolts and Pins to the recommended torque.
- Check the Mower for worn or damaged parts and replace if required.
- Store the Mower in a clean, dry place with the Mower Housing resting securely on blocks.
- Apply spray 'touch up' paint where necessary to prevent rust and maintain the appearance of the Mower.
- Disassemble PTO Slip Clutch and store Friction Plates in a dry place and not in contact with its mating plates (*Friction Plates are Hygroscopic – they attract moisture and encourage corrosion of any metal part they have contact with*).

TORQUE SETTINGS FOR FASTENERS

The Chart below lists the correct tightening torque for fasteners. The Chart should be referred to when tightening or replacing bolts in order to determine the grade of bolt and the correct torque except where specific torque values are assigned in the text of this manual.

Recommended torque is quoted in Foot-Pounds and Newton-Me tres within this m anual. The equation for conversion is 1 Nm. = 0.7376 ft.lbs.

TORQUE VALUES FOR IMPERIAL BOLTS

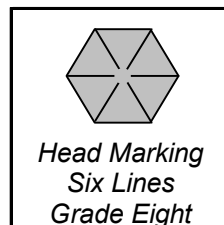
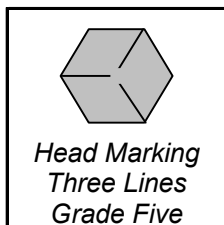
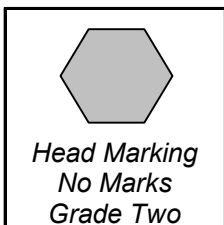
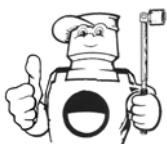

NOTE:
The values in the chart apply to fasteners as received from the supplier, dry or when lubricated with normal engine oil. They DO NOT apply if special graphited, molydisulphide greases, or other extreme pressure lubricants are used. This applies to both UNF and UNC coarse threads.

Bolt Dia.
1/4"
5/16"
3/8"
7/16"
1/2"
9/16"
5/8"
3/4"
7/8"
1"
1-1/8"
1-1/4"
1-3/8"
1-1/2"

Value (Dry)	
ft.lb.	Nm.
5.5	7.5
11	15.0
20	27.0
32	43.0
50	68.0
70	95.0
100	135.0
175	240.0
175	240.0
270	360.0
375	510.0
530	720.0
700	950.0
930	1250.0

Value (Dry)	
ft.lb.	Nm.
9	12.2
18	25.0
33	45.0
52	70.0
80	110.0
115	155.0
160	220.0
280	380.0
450	610.0
675	915.0
850	115.0
1200	1626.0
1550	2100.0
2100	2850.0

Value (Dry)	
ft.lb.	Nm.
12.5	17.0
26	35.2
46	63.0
75	100.0
115	155.0
160	220.0
225	305.0
400	540.0
650	880.0
975	1325.0
1350	1830.0
1950	2650.0
2550	3460.0
3350	4550.0

TORQUE VALUES FOR METRIC BOLTS.

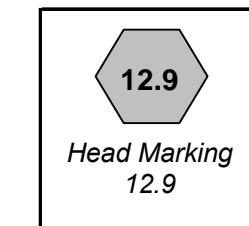
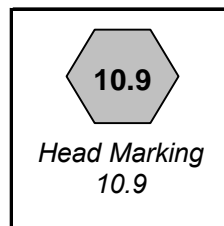
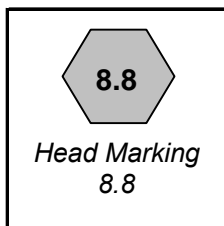
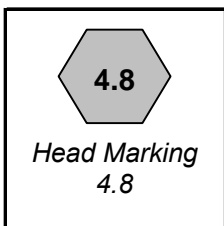

Bolt Dia.
6mm
8mm
10mm
12mm
14mm
16mm
18mm
20mm
22mm
24mm
27mm
30mm

Value (Dry)	
ft.lb.	Nm.
4.5	6.1
11	14.9
21	28.5
37	50.2
60	81.4
92	125.0
125	170.0
180	245.0
250	340.0
310	420.0
450	610.0
625	850.0

Value (Dry)	
ft.lb.	Nm.
8.5	11.5
20	27.1
40	54.2
70	95.0
110	150.0
175	240.0
250	340.0
350	475.0
475	645.0
600	810.0
875	1180.0
1200	1626.0

Value (Dry)	
ft.lb.	Nm.
12	16.3
30	40.1
60	81.4
105	140.0
165	225.0
255	350.0
350	475.0
500	675.0
675	915.0
850	1150.0
1250	1700.0
1700	2300.0

Value (Dry)	
ft.lb.	Nm.
14.5	20.0
35	47.5
70	95.0
120	160.0
190	260.0
300	400.0
410	550.0
580	790.0
800	1090.0
1000	1350.0
1500	2000.0
2000	2700.0

GEARBOX MAINTENANCE

Disassembly and assembly of the 'T' Gearbox requires the following tools.

1. Caulking Gun/Silicon Sealant
2. Torque Wrench
3. Sockets – 10mm & 14mm
4. 3/16" Punch
5. Impact Wrench
6. Retaining Ring Pliers
7. Ball Pin Hammer

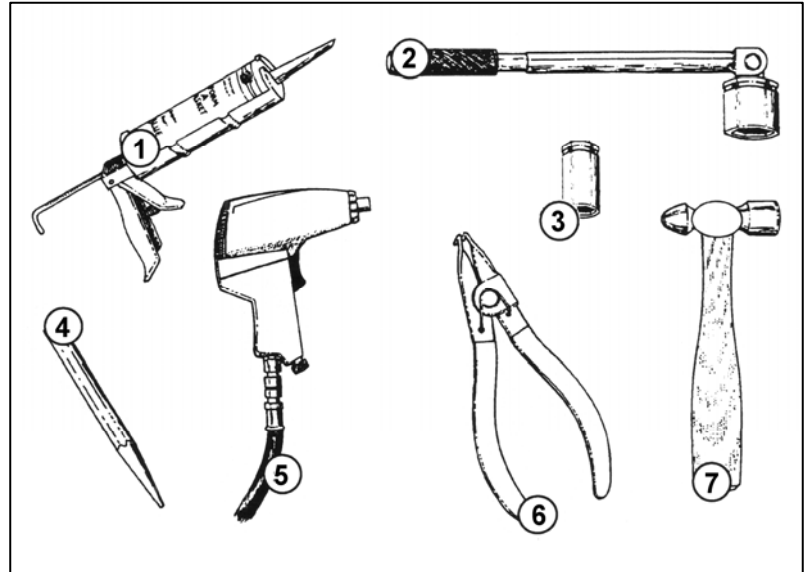

WARNING Ensure Gearbox and Sub-Assemblies are clamped or securely supported to prevent injury to hands and feet due to inadvertent dropping or falling over.



WARNING Always wear Safety Glasses and Gloves to prevent eye and hand injury when chiseling or hammering on metal components. Hardened metal will chip unexpectedly.



WARNING An assembled Gearbox is quite heavy. Use a hoist or get help to handle them safely. Lift carefully and properly using your legs to lift – not your back.



WARNING Refer to the Operator's Section of this Manual for correct re-assembly onto the Mower deck. Tighten correctly.



T-BOX DISASSEMBLY AND ASSEMBLY

The disassembly and assembly procedure for the T-Box is as follows. (The diagram below illustrates the location of components in the T-Box by numbers, which are referred to in the procedure instructions).

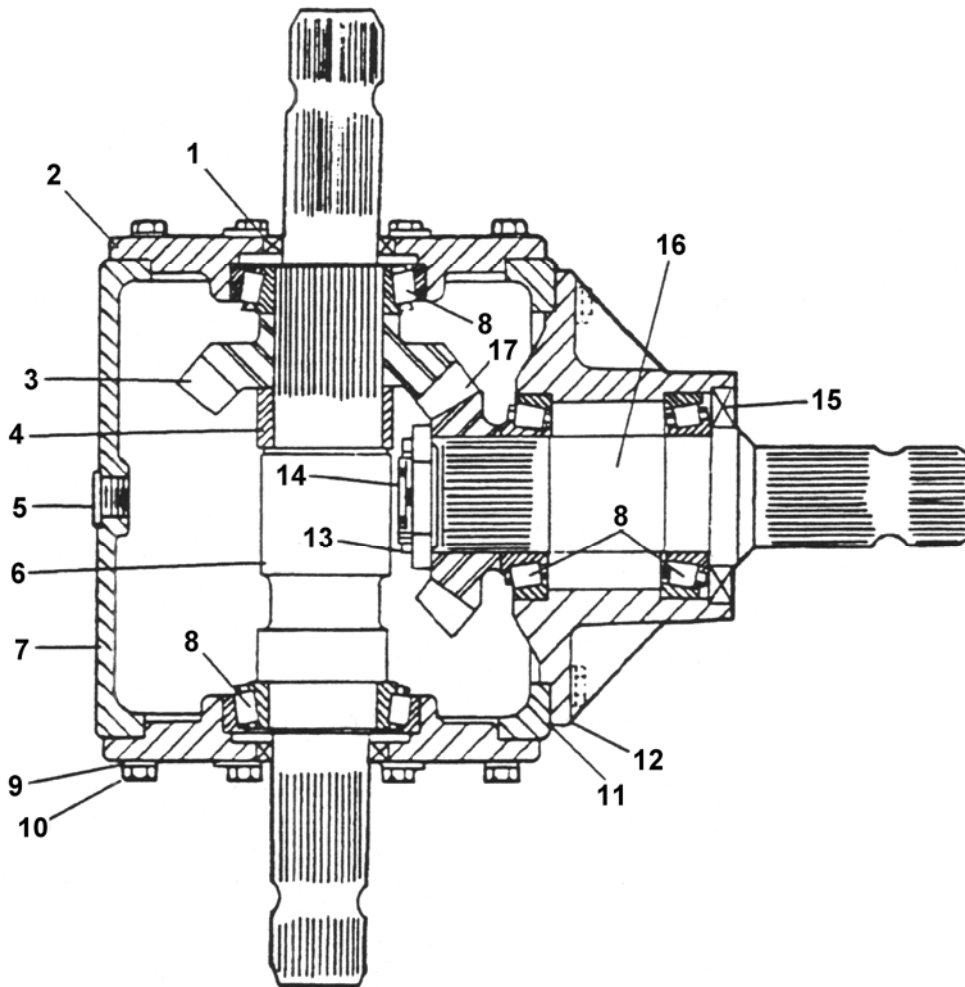

REF.	QTY.	DESCRIPTION	REF.	QTY.	DESCRIPTION
1	2	SEAL	10	24	BOLT
2	2	CAP - SIDE	11	as req.	GASKETS (inc. 0.40, 0.25, & 0.30).
3	1	GEAR	12	1	CAP - HUB INPUT
4	1	SPACER	13	1	ADJUSTING NUT
5	2	PIPE PLUG	14	1	COTTER PIN
6	1	SHAFT	15	1	SEAL
7	1	HOUSING	16	1	SHAFT
8	4	BEARING	17	1	GEAR
9	24	LOCKWASHER	18	1	PIPE PLUG VENTED - not illus.

T-BOX DISASSEMBLY

Remove Main Input Shaft

STEP I.

Drain oil from gearbox. Place gearbox on appropriate work surface. Remove the eight bolts that retain the input housing hub. Remove hub assembly from main housing. *Note quantity and thickness of shims between hub and main housing.*

STEP II.

Remove cotter pin (14) and adjusting nut (13).

STEP III.

Remove gear (17). Tap on threaded end of shaft (16) to remove from hub.

STEP IV.

Press bearing cone (8) from shaft (16).

STEP V.

Remove bearing cups (8) from hub housing.

STEP VI.

Remove eight bolts (10) from one side cap (2). Tap on opposite side shaft end (6) to remove side cap (2) and on side shaft assembly.

STEP VII.

Remove eight bolts retaining remaining side cap (2) in place. Using end of hammer handle, tap inside of cap to remove from main housing. *Note quantity and thickness of shims under both side caps.*

STEP VIII.

Lap shaft ends on solid metal surface to remove bearings (8), gear (3), and spacer (4).

Mark side cap which was closest to gear and main housing, so that it may be reassembled later in the same location

The Gearbox is now completely disassembled. Inspect and replace all worn or damaged parts.

T-BOX ASSEMBLY

Assembly can be accomplished by reversing the disassembly procedure. *Ensure your work area is clean before starting to reduce the possibility of dirt or grit getting into components during assembly.*

STEP I.

Install spacer (4), gear (3), and bearing cones (8) onto the shaft. If any shims were present between bearing and gear or gear and spacer always reinstall at the same location. Ensure that all parts are fully seated.

STEP II.

Press new bearing cups into side caps (2).

STEP III.

Assemble side cap (2), which was against the gear onto main housing, using same shim pack as when disassembled. If shim pack not available use .030 inches of total shim thickness. Install capscrews and tighten to recommended torque. Install the shaft assembly into housing with gear against the first side cap.

STEP IV.

Assemble second side cap (2) onto main housing (7), using same shim pack as when disassembled, or if not available use .030 inch shim between cap and housing. Install capscrews (12) and tighten.

STEP V.

Check bearing adjustment on rolling torque on cross shaft. If endplay exists in shaft, shims must be removed from stand side cap or cap opposite plan (3). Proper rolling torque should be 10-12 inch pounds (1.1-1.36 Nm). If preload is tight shims must be added under side cap opposite gear.

GEARBOX DISASSEMBLY AND ASSEMBLY

The disassembly and assembly procedure for the Gearbox is as follows. (The diagram below illustrates the location of components in the Gearbox by numbers, which are referred to in the procedure instructions).

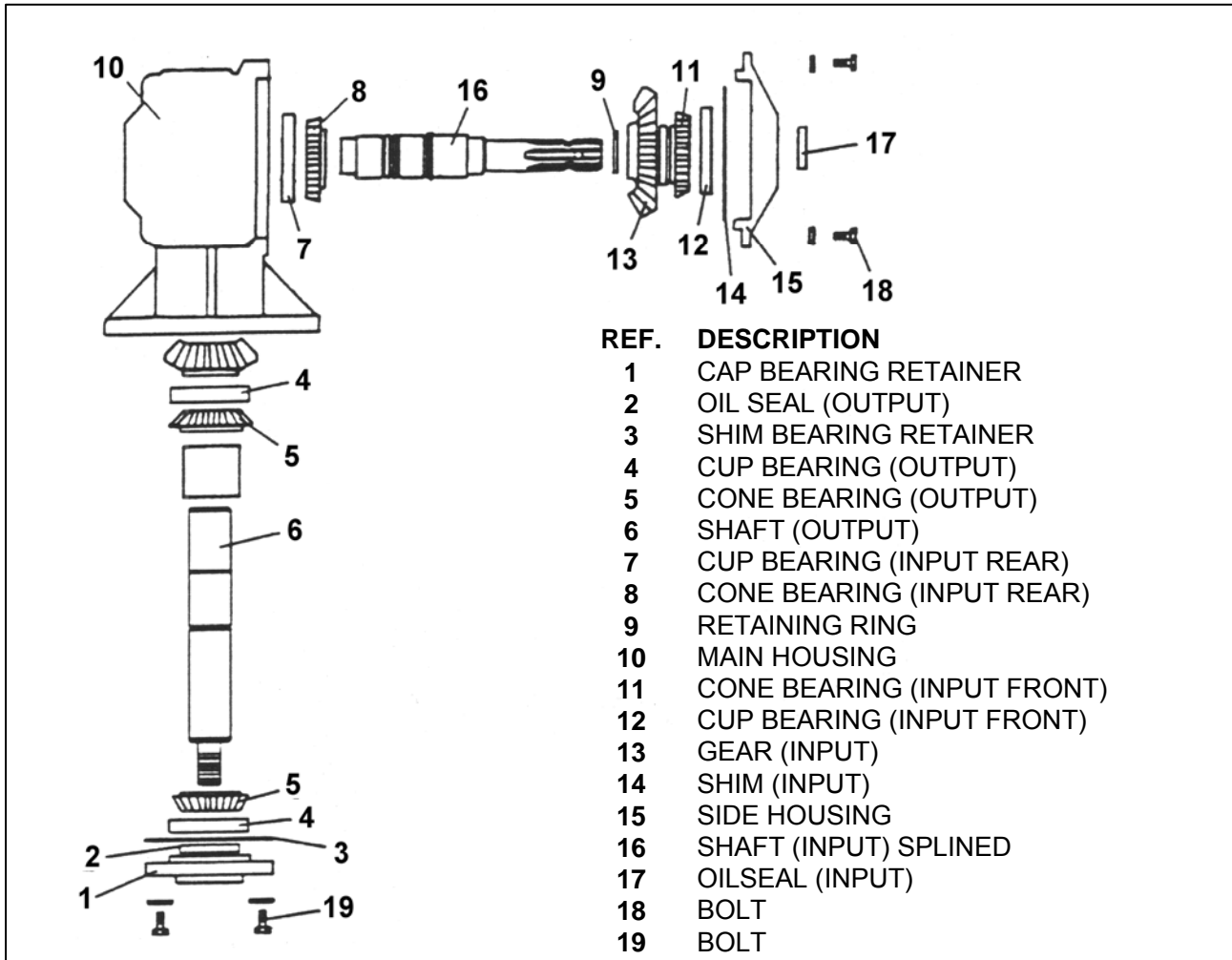

GEARBOX DISASSEMBLY

- Remove eight bolts **(18)** from input shaft bearing housing **(15)**.
- Tap around circumference of bearing housing **(15)** to loosen housing and shims. Remove housing – *it may be necessary to pry the housing to remove*. Grasp end of shaft and draw the complete shaft assembly from housing. Remove gear **(13)** from shaft **(6)**.
- Remove four capscrews **(19)**, break gasket loose, and remove bearing retainer cap **(1)**.
- Output shaft assembly must be removed from main housing by driving or pulling out bottom end. The simplest method of removing the output shaft assembly is to attach a 'slide hammer puller' to the shaft and use that to pull out the shaft.
- The gearbox is now disassembled into 5 sub-assemblies:
 1. Input shaft assembly
 2. Output shaft assembly
 3. Lower bearing retainer assembly
 4. Main housing assembly
 5. Input shaft bearing housing

INPUT SHAFT DISASSEMBLY AND ASSEMBLY

- Remove bearing **(11)** nearest input shaft bearing housing by tapping end on a solid surface. Shock force will remove bearing **(11)** and gear **(13)**. Remove bearing **(8)** from opposite end of shaft. *Note presence and location of any shims or spacers so they may be reassembled in the same position.*
- Worn components can now be replaced and assembled in reverse order.

ASSEMBLY ORDER

- Install gear **(13)** onto shaft **(16)**.
- Install bearing **(11)** on shaft against gear. *NOTE: Use a tube with an inside diameter just large enough to go over the shaft to drive the bearing against the gear.*
- Install bearing **(8)** on opposite end of the shaft. *NOTE: Always support the assembly so that the bearing on the opposing end is not damaged during assembly.*

OUTPUT SHAFT DISASSEMBLY AND ASSEMBLY

- Install slotted nut onto shaft **(6)** and then tap shaft end on a solid surface to remove lower bearing **(5)**. Repeat procedure for opposite end of shaft.
- Replace worn parts and assemble in reverse order.

LOWER BEARING RETAINER CAP

- Remove old seal **(2)** from cap **(1)** and press in new seal. (See 'Seal Installation Recommendations' below).

MAIN GEARBOX

- Remove bearing cup **(7)** from inside main housing. *A special 'slide hammer puller' may be required to remove the bearing cup.* Press in new bearing cup using driving tube or pipe with approximately the same outside diameter as the cup. Seat bearing cup against the shoulder in the housing.

INPUT SHAFT BEARING HOUSING

- Remove seal **(17)** and bearing cup **(12)**. Press new cup and seal back in place. (See 'Seal Installation Recommendations' below).
- Press oil seal flush with front side of bearing housing.

SEAL INSTALLATION RECOMMENDATIONS

1. Check Seal – for damage that may have occurred prior to installation. A sealing lip that is turned back, cut or otherwise damaged should be replaced.
2. Check Bore – to see that leading edge is deburred. A rounded corner or chamfer should be provided.

3. Check shaft – remove surface nicks, burrs and grooves and lubricate with a hard fibrous grease. *NOTE: Wrap plastic tape around irregular shaft surfaces such as splines to protect seal during assembly.*
4. Use correct installation tool – Always use a pipe or a tube with approximately the same outside diameter as the seal and press the seal by striking the tube.

NEVER HAMMER DIRECTLY ON THE SURFACE OF THE SEAL.

GEARBOX ASSEMBLY

Clean and scrape all gasket surfaces.

- Insert output shaft assembly including upper bearing (5), retaining ring (10) spacer (22) and lower bearing (5) into housing. Insert lower bearing cup (4) and press down against bearing cone using tube slightly smaller than outside diameter of the cup.
- Pre-lube lower bearing.
- Place two shims in place and carefully slide bearing retainer cap assembly down shaft. *NOTE: Lubricate the inside diameter of the seal before inserting over shaft.*
- Install bolts and lock washers and torque to 85-105 ft.lbs. (115-142 Nm).
- Check bearing preload (*Specification 8-16 inch-pounds*). This must be measured with an inch-pound Torque Wrench. This measurement is the amount of force required to rotate the shaft. *NOTE: If a Torque Wrench is not available, the following method can be used -* Wrap a small diameter strong string several turns around the threaded end of the output shaft and attach an 8 lb. (3.6kg) weight to the string. If the weight will rotate the shaft then preload must be increased by removing a shim (3) and then rechecking. Check high limit of specification by attaching a 16 lb. (7.2kg) weight to the string. If 16 lb. weight fails to turn the shaft the bearing preload is too high and a shim must be added. There are .007 and .010 shims available. Once shim pack is established, remove lower cap, apply a thin coat of 'permatex', or equivalent, reinstall and torque the capscrews.
- Install gear (13) onto shaft (6). Install input shaft into main housing. Assemble three shims (14), lubricate the seal inner diameter in bearing support-housing (16), and carefully insert over shaft. Rotate bearing housing so that large ½ plug is directly over input shaft and the oil level check plug is below and to side of shafts.
- Install lock washers and bolts and torque to 40-50 ft. lb. (54.2-67.8 Nm).

GEAR BACKLASH CHECK PROCEDURE – See diagram below.

- Set dial indicator at marked point at bottom of spline, then While holding bottom shaft so it will not rotate; rotate the Input shaft back and forth noting extreme indicator readings. If total indicator deflection reading does not fall between .002 to .006 (0.05 to 0.15mm) then shims will have to be added to increase backlash or removed to decrease backlash. Once shim pack determined remove support housing and apply a thin coat of 'permatex', or similar, and reinstall and torque capscrews.

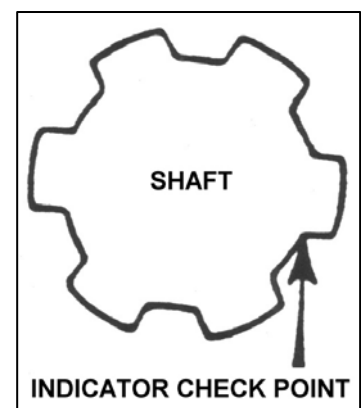

Remove ½” pipe plug and fill gearbox with the correct recommended lubricant.

- Install pipe plug and gearbox assembly is complete.

STEP VI.

Input Hub Assembly

Press bearing cups into hub ensuring they are fully seated. Press bearing cone onto the shaft ensuring it is properly seated against the shaft shoulder. Assemble shaft into hub (12), add second bearing cone and gear. Apply a thin coat of ‘Locktite’, or similar, to the shaft threads. Assemble adjusting nut and tighten to insure that all parts are seated. Then loosen the adjusting nut until a rolling torque of 10 to 12 inch pounds (1.1 to 1.36 Nm) is reached. Insert cotter pin through shaft and adjusting nut. Bend cotter pin ends around radial surface of the nut. **Do not bend cotter over end of shaft - it will foul the output shaft.**

STEP VII.

Assemble input hub into main housing using same shim pack as when disassembled. If not available .020” shim to start. Install bolts and tighten to recommended torque.

STEP VIII.

Check backlash between gear set. Backlash should be .012” to .024” (0.3 to 0.6mm). If backlash is too small, add shims between main housing and input hub. Remove shims for excessive backlash.

STEP IX.

Remove side caps one at a time, seal with ‘sealer’ and reinstall. Repeat process for input hub assembly. Gearbox is now ready to be filled with a good grade of EP-90 oil. (See *Maintenance Section for specification*).

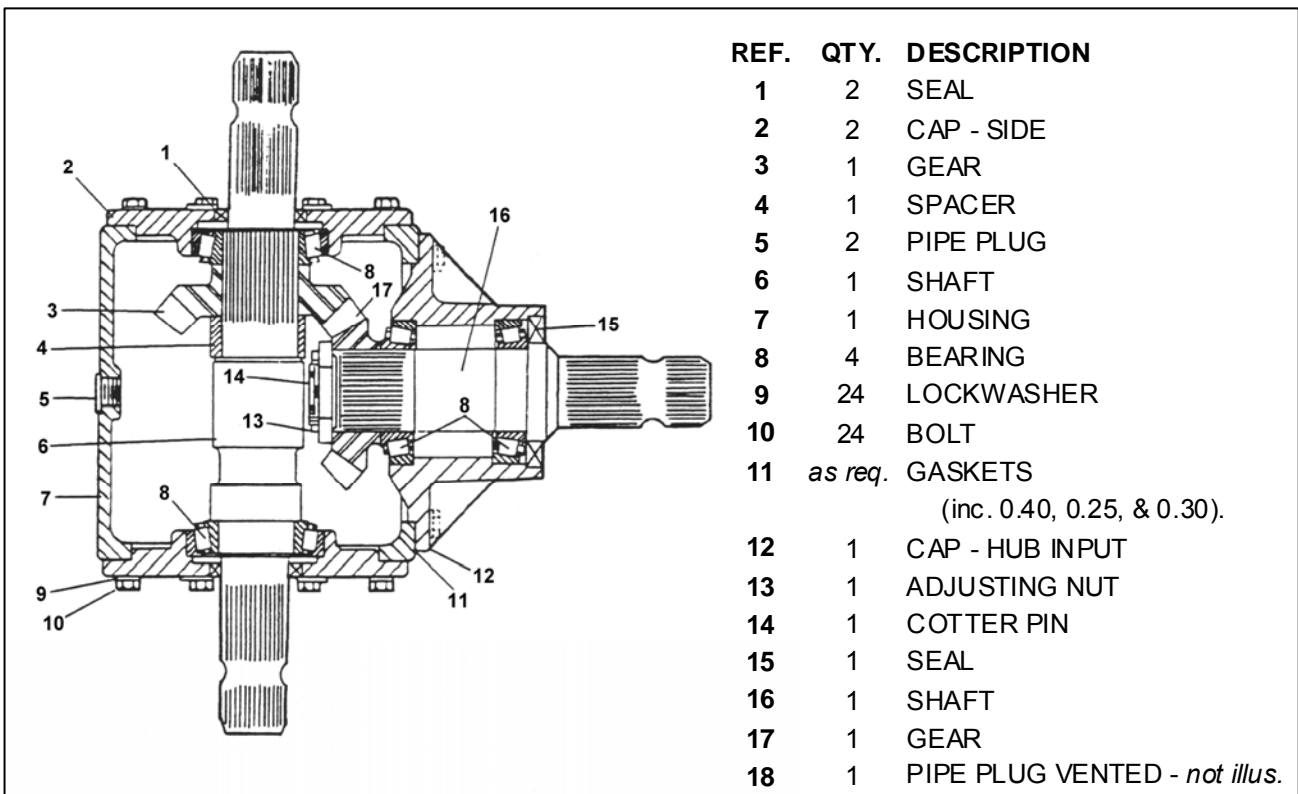



McConnel Limited, Temeside Works, Ludlow, Shropshire SY8 1JL. England.
Telephone: 01584 873131. Facsimile: 01584 876463. www.mcconnel.com