

Publication 608
July 2009
Part No. 22674.08
Revision: 18.04.19



McCONNEL

SR420

ROTARY WING MOWER

Operator Manual



IMPORTANT

VERIFICATION OF WARRANTY REGISTRATION



DEALER WARRANTY INFORMATION & REGISTRATION VERIFICATION

It is imperative that the selling dealer registers this machine with McConnel Limited before delivery to the end user – failure to do so may affect the validity of the machine warranty.

To register machines go to the McConnel Limited web site at www.mcconnel.com, log onto 'Dealer Inside' and select the 'Machine Registration button' which can be found in the Service Section of the site. Confirm to the customer that the machine has been registered in the section below.

Should you experience any problems registering a machine in this manner please contact the McConnel Service Department on 01584 875848.

Registration Verification

Dealer Name:
Dealer Address:
Customer Name:
Date of Warranty Registration:/...../..... Dealer Signature:

NOTE TO CUSTOMER / OWNER

Please ensure that the above section above has been completed and signed by the selling dealer to verify that your machine has been registered with McConnel Limited.

IMPORTANT: During the initial 'bedding in' period of a new machine it is the customer's responsibility to regularly inspect all nuts, bolts and hose connections for tightness and re-tighten if required. New hydraulic connections occasionally weep small amounts of oil as the seals and joints settle in – where this occurs it can be cured by re-tightening the connection – *refer to torque settings chart below*. The tasks stated above should be performed on an hourly basis during the first day of work and at least daily thereafter as part of the machines general maintenance procedure.

CAUTION: DO NOT OVER TORQUE HYDRAULIC FITTINGS AND HOSES

TORQUE SETTINGS FOR HYDRAULIC FITTINGS

HYDRAULIC HOSE ENDS		
BSP	Setting	Metric
1/4"	18 Nm	19 mm
3/8"	31 Nm	22 mm
1/2"	49 Nm	27 mm
5/8"	60 Nm	30 mm
3/4"	80 Nm	32 mm
1"	125 Nm	41 mm
1.1/4"	190 Nm	50 mm
1.1/2"	250 Nm	55 mm
2"	420 Nm	70 mm

PORT ADAPTORS WITH BONDED SEALS		
BSP	Setting	Metric
1/4"	34 Nm	19 mm
3/8"	47 Nm	22 mm
1/2"	102 Nm	27 mm
5/8"	122 Nm	30 mm
3/4"	149 Nm	32 mm
1"	203 Nm	41 mm
1.1/4"	305 Nm	50 mm
1.1/2"	305 Nm	55 mm
2"	400 Nm	70 mm

WARRANTY POLICY

WARRANTY REGISTRATION

All machines must be registered, by the selling dealer with McConnel Ltd, before delivery to the end user. On receipt of the goods it is the buyer's responsibility to check that the Verification of Warranty Registration in the Operator's Manual has been completed by the selling dealer.

1. LIMITED WARRANTIES

- 1.01. *All mounted machines supplied by McConnel Ltd are warranted to be free from defects in material and workmanship from the date of sale to the original purchaser for a period of 12 months, unless a different period is specified.
All Self Propelled Machines supplied by McConnel Ltd are warranted to be free from defects in material and workmanship from the date of sale to the original purchaser for a period of 12 months or 1500 hours. Engine warranty will be specific to the Manufacturer of that unit.*
- 1.02. *All spare parts supplied by McConnel Ltd and purchased by the end user are warranted to be free from defects in material and workmanship from the date of sale to the original purchaser for a period of 6 months. All parts warranty claims must be supported by a copy of the failed part invoice to the end user. We cannot consider claims for which sales invoices are not available.*
- 1.03. *The warranty offered by McConnel Ltd is limited to the making good by repair or replacement for the purchaser any part or parts found, upon examination at its factory, to be defective under normal use and service due to defects in material or workmanship. Returned parts must be complete and unexamined. Pack the component(s) carefully so that any transit damage is avoided. All ports on hydraulic items should be drained of oil and securely plugged to prevent seepage and foreign body ingress. Certain other components, electrical items for example, may require particular care when packing to avoid damage in transit.*
- 1.04. *This warranty does not extend to any product from which McConnel Ltd's serial number plate has been removed or altered.*
- 1.05. *The warranty policy is valid for machines registered in line with the terms and conditions detailed and on the basis that the machines do not extend a period of 24 months or greater since their original purchase date, that is the original invoice date from McConnel Limited.
Machines that are held in stock for more than 24 months cannot be registered for warranty.*
- 1.06. *This warranty does not apply to any part of the goods, which has been subjected to improper or abnormal use, negligence, alteration, modification, fitment of non-genuine parts, accident damage, or damage resulting from contact with overhead power lines, damage caused by foreign objects (e.g. stones, iron, material other than vegetation), failure due to lack of maintenance, use of incorrect oil or lubricants, contamination of the oil, or which has served its normal life. This warranty does not apply to any expendable items such as blades, belts, clutch linings, filter elements, flails, flap kits, skids, soil engaging parts, shields, guards, wear pads, pneumatic tyres or tracks.*
- 1.07. *Temporary repairs and consequential loss - i.e. oil, downtime and associated parts are specifically excluded from the warranty.*
- 1.08. *Warranty on hoses is limited to 12 months and does not include hoses which have suffered external damage. Only complete hoses may be returned under warranty, any which have been cut or repaired will be rejected.*
- 1.09. *Machines must be repaired immediately a problem arises. Continued use of the machine after a problem has occurred can result in further component failures, for which McConnel Ltd cannot be held liable, and may have safety implications.*
- 1.10. *If in exceptional circumstances a non McConnel Ltd part is used to effect a repair, warranty reimbursement will be at no more than McConnel Ltd's standard dealer cost for the genuine part.*

- 1.11. *Except as provided herein, no employee, agent, dealer or other person is authorised to give any warranties of any nature on behalf of McConnell Ltd.*
- 1.12. *For machine warranty periods in excess of 12 months the following additional exclusions shall apply:*
 - 1.12.1. *Hoses, exposed pipes and hydraulic tank breathers.*
 - 1.12.2. *Filters.*
 - 1.12.3. *Rubber mountings.*
 - 1.12.4. *External electric wiring.*
 - 1.12.5. *Bearings and seals*
 - 1.12.6. *External Cables, Linkages*
 - 1.12.7. *Loose/Corroded Connections, Light Units, LED's*
 - 1.12.8. *Comfort items such as Operator Seat, Ventilation, Audio Equipment*
- 1.13. *All service work, particularly filter changes, must be carried out in accordance with the manufacturer's service schedule. Failure to comply will invalidate the warranty. In the event of a claim, proof of the service work being carried out may be required.*
- 1.14. *Repeat or additional repairs resulting from incorrect diagnosis or poor quality previous repair work are excluded from warranty.*

NB Warranty cover will be invalid if any non-genuine parts have been fitted or used. Use of non-genuine parts may seriously affect the machine's performance and safety. McConnell Ltd cannot be held responsible for any failures or safety implications that arise due to the use of non-genuine parts.

2. REMEDIES AND PROCEDURES

- 2.01. *The warranty is not effective unless the Selling Dealer registers the machine, via the McConnell web site and confirms the registration to the purchaser by completing the confirmation form in the operator's manual.*
- 2.02. *Any fault must be reported to an authorised McConnell Ltd dealer as soon as it occurs. Continued use of a machine, after a fault has occurred, can result in further component failure for which McConnell Ltd cannot be held liable.*
- 2.03. *Repairs should be undertaken within two days of the failure. Claims submitted for repairs undertaken more than 2 weeks after a failure has occurred, or 2 days after the parts were supplied will be rejected, unless the delay has been authorised by McConnell Ltd. Please note that failure by the customer to release the machine for repair will not be accepted as a reason for delay in repair or submitting warranty claims.*
- 2.04. *All claims must be submitted, by an authorised McConnell Ltd Service Dealer, within 30 days of the date of repair.*
- 2.05. *Following examination of the claim and parts, McConnell Ltd will pay, at their discretion, for any valid claim the invoiced cost of any parts supplied by McConnell Ltd and appropriate labour and mileage allowances if applicable.*
- 2.06. *The submission of a claim is not a guarantee of payment.*
- 2.07. *Any decision reached by McConnell Ltd. is final.*

3. LIMITATION OF LIABILITY

- 3.01. *McConnell Ltd disclaims any express (except as set forth herein) and implied warranties with respect to the goods including, but not limited to, merchantability and fitness for a particular purpose.*
- 3.02. *McConnell Ltd makes no warranty as to the design, capability, capacity or suitability for use of the goods.*
- 3.03. *Except as provided herein, McConnell Ltd shall have no liability or responsibility to the purchaser or any other person or entity with respect to any liability, loss, or damage caused or alleged to be caused directly or indirectly by the goods including, but not limited to, any indirect, special, consequential, or incidental damages resulting from the use or operation of the goods or any breach of this warranty. Notwithstanding the above limitations and warranties, the manufacturer's liability hereunder for damages incurred by the purchaser or others shall not exceed the price of the goods.*
- 3.04. *No action arising out of any claimed breach of this warranty or transactions under this warranty may be brought more than one (1) year after the cause of the action has occurred.*

4. MISCELLANEOUS

- 4.01. McConnel Ltd may waive compliance with any of the terms of this limited warranty, but no waiver of any terms shall be deemed to be a waiver of any other term.*
- 4.02. If any provision of this limited warranty shall violate any applicable law and is held to be unenforceable, then the invalidity of such provision shall not invalidate any other provisions herein.*
- 4.03. Applicable law may provide rights and benefits to the purchaser in addition to those provided herein.*

McConnel Limited



DECLARATION OF CONFORMITY

Conforming to EU Machinery Directive 2006/42/EC

We,

McCONNEL LIMITED, Temeside Works, Ludlow, Shropshire SY8 1JL, UK

Hereby declare that:

The Product; *Tractor Trailed Flex Wing Mower*

Product Code; *MR42, MR46, MR62, MR82*

Serial No. & Date Type

Manufactured in; *United Kingdom*

Complies with the required provisions of the Machinery Directive 2006/42/EC
The machinery directive is supported by the following harmonized standards;

- BS EN ISO 12100 (2010) Safety of machinery – General principles for design – Risk assessment and risk reduction.
- BS EN 349 (1993) + A1 (2008) Safety of machinery - Minimum distances to avoid the entrapment with human body parts.
- BS EN ISO 14120 (2015) Safety of machinery - Guards general requirements for the design and construction of fixed and movable guards.
- BS EN 4413 (2010) Hydraulic fluid power. Safety requirements for systems and their components.

McCONNEL LIMITED operates an ISO 9001:2008 quality management system, certificate number: FM25970.

This system is continually assessed by the;

British Standards Institution (BSI), Beech House, Milton Keynes, MK14 6ES, UK

BSI is accredited by UK Accreditation Service, accreditation number: UKAS 003.

The EC declaration only applies if the machine stated above is used in accordance with the operating instructions.

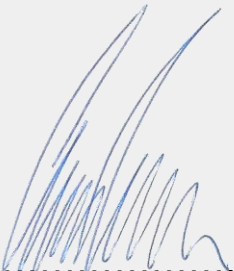
Signed  *Responsible Person*
CHRISTIAN DAVIES on behalf of McCONNEL LIMITED

Status: *General Manager*

Date: *January 2018*

ROTARY MOWER INSPECTION AND MAINTENANCE

A daily equipment inspection of the tractor and mower should be conducted before the equipment is used. You may use the inspection sheets to assist with these daily inspections. Any damaged or missing guards should be repaired or replaced before operating the mower. Failure to repair the damaged shield can result in objects being thrown from the mower and possibly hitting the operator or bystander.

Inspect the Mower for Safe Operating Condition

- Make sure the driveline guards and shielding are in place and in good repair.
- Inspect the chain guards, flexible and/or solid deflector thrown object shielding to assure that they are in place on the front and rear of the mower deck and in good repair. Repair or replace any damaged or missing thrown object shields.
- Remove all debris and cut material from the deck and around the gearboxes.
- Ensure the mower cutting height is set high enough to reduce the possibility of the mower blades contacting the ground. Actual height will be dependent on the ground conditions. Increase the height when working in rough or undulating conditions.
- Inspect for broken, chipped, bent, missing, or severely worn blades. Replace damaged blades before operating the mower. Ensure the blade retaining bolts and fasteners are secure and tight.
- Lubricate the driveline universal joints and telescoping members daily.
- Inspect the wheel lug bolt/nuts to assure that they are tight.
- If mower is equipped with pneumatic tires, make sure they have the required air pressure.
- Inspect for worn or damaged decals and safety instructions. Replace unreadable, damaged or missing safety decals.
- Follow the operator's manual(s) inspection and maintenance instructions for lubricating parts, and keeping thrown object shielding, driveline guards, rotating parts shields, mower blades and decals in good repair.

Inspect the Tractor for Safe Operating Condition:

- Inspect the controls, lights, SMVs (Slow Moving Vehicle sign), seat belts, and ROPS to assure that they are in place and in good working order.
- Be sure the tires, wheels, lug bolts/nuts are in good condition.
- Make sure the tractor brakes and steering are in proper operating condition.
- Follow the operator's manual(s) inspection and maintenance procedures for keeping the tractor in good and safe condition before operating.

The inspection sheet on the following page should be kept in this book as a record. A second sheet is included for you to cut out and photocopy or the inspection sheets can be downloaded from our web site at;

<http://www.mcconnel.com/support/aftersales/default.aspx?nav=After Sales>



FLEX WING MOWER PRE-OPERATION Inspection

Mower ID _____ Date: _____ Shift: _____

WARNING



Before conducting the inspection, make sure the tractor engine is off, the key removed, all rotation has stopped and the tractor is in park with the parking brake engaged. Make sure the mower wings are resting on the ground or securely blocked up, or are retained in the transport by pins and all hydraulic pressure has been relieved.

Item	Condition at start of shift	Specific Comments if not O.K.
The Operator's Manual is in the Canister on the mower		
All Warning Decals are in place and legible		
All Lights are clean and working		
Tongue/Hitch connection bolts & pins are tight		
There are no cracks in Tongue or Hitch		
Hyd. Cylinder pins are properly retained		
There are no oil leaks		
There are no damaged hoses		
Gearboxes & mower decks are clear of cut grass and debris		
Chain Guards/Deflectors are in place & in good condition		
Driveline/Gearbox shields/guards are in good condition		
Driveline clutches are in good condition, not frozen		
Driveline telescoping members & u-joints are lubricated		
Driveline yokes are securely attached to tractor & mower		
Gearbox mounting bolts are tight		
Blade carrier retaining nut is tight		
Blades are not chipped, cracked, bent or worn out		
Blade bolts are tight		
Side skirts and skids are in good condition		
There are no holes or cracks in the machine deck		
Wheel nuts are tight		
Tyre pressures are correct		
Transport locks are in good condition		
All axle mounting pins are correctly secured		

Operators Signature: _____

DO NOT OPERATE an UNSAFE TRACTOR or MOWER



TRACTOR PRE-OPERATION Inspection

Power Arm ID _____ Date: _____ Shift: _____

WARNING



Before conducting the inspection, make sure the tractor engine is off, the key is removed all rotation has stopped and the tractor is in park with the parking brake engaged. Any implement attached to the tractor is firmly on the ground.

Item	Condition at start of shift	Specific Comments if not O.K.
The flashing lights function properly.		
All lights are clean and working correctly		
All cab windows are clean and wipers working correctly		
The SMV sign, where required, is clean and visible.		
The tyres are in good condition with correct pressure.		
The wheel nuts are tight.		
The tractor brakes are in good condition.		
The steering linkage is in good condition.		
There are no visible oil leaks.		
The hydraulic controls function properly.		
The ROPS or ROPS cab is in good condition.		
The seatbelt is in place and in good condition.		
The 3-point hitch is in good condition.		
The drawbar/pick up hook is secure & in good condition		
The PTO master shield is in place.		
The engine oil level is full.		
The brake fluid level is full.		
The power steering fluid level is full.		
The fuel level is adequate.		
The engine coolant fluid level is full.		
The radiator & oil cooler are free of debris.		
The air filter is in good condition		

Operators Signature: _____

DO NOT OPERATE an UNSAFE TRACTOR or MOWER



FLEX WING MOWER PRE-OPERATION Inspection

Mower ID _____ Date: _____ Shift: _____

WARNING



Before conducting the inspection, make sure the tractor engine is off, the key removed, all rotation has stopped and the tractor is in park with the parking brake engaged. Make sure the mower wings are resting on the ground or securely blocked up, or are retained in the transport by pins and all hydraulic pressure has been relieved.

Item	Condition at start of shift	Specific Comments if not O.K.
The Operator's Manual is in the Canister on the mower		
All Warning Decals are in place and legible		
All Lights are clean and working		
Tongue/Hitch connection bolts & pins are tight		
There are no cracks in Tongue or Hitch		
Hyd. Cylinder pins are properly retained		
There are no oil leaks		
There are no damaged hoses		
Gearboxes & mower decks are clear of cut grass and debris		
Chain Guards/Deflectors are in place & in good condition		
Driveline/Gearbox shields/guards are in good condition		
Driveline clutches are in good condition, not frozen		
Driveline telescoping members & u-joints are lubricated		
Driveline yokes are securely attached to tractor & mower		
Gearbox mounting bolts are tight		
Blade carrier retaining nut is tight		
Blades are not chipped, cracked, bent or worn out		
Blade bolts are tight		
Side skirts and skids are in good condition		
There are no holes or cracks in the machine deck		
Wheel nuts are tight		
Tyre pressures are correct		
Transport locks are in good condition		
All axle mounting pins are correctly secured		

Operators Signature: _____

DO NOT OPERATE an UNSAFE TRACTOR or MOWER



TRACTOR PRE-OPERATION Inspection

Power Arm ID _____ Date: _____ Shift: _____

WARNING



Before conducting the inspection, make sure the tractor engine is off, the key is removed all rotation has stopped and the tractor is in park with the parking brake engaged. Any implement attached to the tractor is firmly on the ground.

Item	Condition at start of shift	Specific Comments if not O.K.
The flashing lights function properly.		
All lights are clean and working correctly		
All cab windows are clean and wipers working correctly		
The SMV sign, where required, is clean and visible.		
The tyres are in good condition with correct pressure.		
The wheel nuts are tight.		
The tractor brakes are in good condition.		
The steering linkage is in good condition.		
There are no visible oil leaks.		
The hydraulic controls function properly.		
The ROPS or ROPS cab is in good condition.		
The seatbelt is in place and in good condition.		
The 3-point hitch is in good condition.		
The drawbar/pick up hook is secure & in good condition		
The PTO master shield is in place.		
The engine oil level is full.		
The brake fluid level is full.		
The power steering fluid level is full.		
The fuel level is adequate.		
The engine coolant fluid level is full.		
The radiator & oil cooler are free of debris.		
The air filter is in good condition		

Operators Signature: _____

DO NOT OPERATE an UNSAFE TRACTOR or MOWER

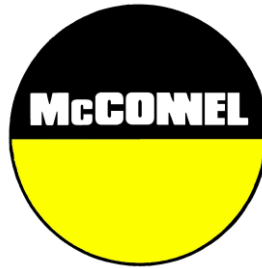

For Safety and Performance...

ALWAYS READ THE BOOK FIRST

McCONEL LIMITED

**Temeside Works
Ludlow
Shropshire
England**

**Telephone: +44 (0)1584 873131
www.mcconel.com**

- NOISE STATEMENT -

The equivalent daily personal noise exposure from this machine measured at the operators' ear is within the range 78 – 85 dB, these figures apply to a normal distribution of use where the noise fluctuates between zero and maximum. The figures assume that the machine is fitted to a tractor with a 'quiet' cab with the windows closed in a generally open environment. We recommend that the windows are kept closed. With the cab rear window open the equivalent daily personal noise exposure will increase to a figure within the range 82 – 88 dB. At an equivalent daily noise exposure level of 85 – 90 dB ear protection is recommended and must always be used if any window is left open.



Operating, servicing and maintaining this equipment can expose you to chemicals including gasoline, diesel fuel, lubricants, petroleum products, engine exhaust, carbon monoxide, and phthalates, which are known to the State of California to cause cancer and birth defects or other reproductive harm. To minimize exposure, avoid breathing exhaust, do not idle the engine except as necessary, service your vehicle in a well-ventilated area and wear gloves or wash your hands frequently when servicing your vehicle. Battery posts, terminals and related accessories contain lead and lead compounds, chemicals known to the state of California to cause cancer, birth defects or other reproductive harm. For more information go to www.P65Warnings.ca.gov. This website, operated by California's Office of Environmental Health Hazard Assessment, provides information about these chemicals and how individuals may be exposed to them.

LIST OF CONTENTS

	Page No.
Introduction	1
Tractor Requirements	1
Safety Information	2
Electrical & Fire Hazard Safety	5
Safety Decals	6
Tractor Attachment	7
PTO Shaft	7
Machine Setup	8
Operation	9
Transportation	10
Machine Protection - <i>Slip Clutch</i>	10
Service & Maintenance	11
Troubleshooting Guide	17

INTRODUCTION

The SR420 Rotary Wing Mower is a heavy duty rotary mower primarily designed for set-aside, stubble and pasture topping work. With a cutting width of 4.2m they are suitable for use with tractors of between 85 and 120HP.

The cutting height of the machine is controlled and regulated via the rear centre deck wheels and adjustable wing skids with addition wing wheels offered as an option.

The wings of the machine 'float' mechanically during work to eliminate ram seal wear and are raised by independent single acting hydraulic rams for transportation of the machine – mechanical lift locks are provided for complete safety. Power from the tractor to the machine is transferred via a series of gearboxes and PTO shafts with slip clutch protection to absorb shock loads and protect driveline components.

For personal safety and protection of components the machines should never be used to perform tasks they were not designed to do.

TRACTOR REQUIREMENTS

The tractors used should be:

- Minimum of 85HP.
- Equipped with Category 2 three-point linkage.
- Fitted with Check Chains and/or Stabilisers and correctly tightened (*We particularly recommend 'turnbuckle' type Check Chains*).
- Minimum weight of 3700kg.
- 1000RPM PTO.
- Equipped with 1 external hydraulic service, single acting with float facility for wings.
- Sufficient weight on the front wheels to ensure stability during transportation and work. Extra ballast should be added if required.
- Before attachment; set lift rods to equal length and ensure position control is selected - never attempt to hitch in draft control.

SAFETY

Safety Information

Read, Understand and Follow the Safety Messages - Serious injury or death may occur unless care is taken to follow the warnings and instructions given in the safety messages,

CAUTION! The lowest level of Safety Message; warns of possible injury.

WARNING! Serious injury or possible death.

DANGER! Imminent death/critical injury.

Never operate the tractor or machinery until you have read and completely understand this manual and the tractor operator's manual and each of the safety messages found in the manuals and those displayed on the tractor and implement.

DANGER! DO NOT attempt any maintenance of or adjustment to the machine while it is running. Before carrying out any work on the machine follow the three safety instructions below:

- a LOWER THE MACHINE ON TO THE GROUND
- b PUT THE PTO OUT OF GEAR
- c STOP THE TRACTOR ENGINE

WARNING! The operator and all support personnel must wear the appropriate safety clothing i.e. safety glasses and safety shoes at all times for protection from injury by objects thrown from the machine.

DANGER! Never allow passengers especially children to ride on the tractor or implement. Falling off can kill.

DANGER! Do not mount or dismount the tractor or machine while it is moving. Mount or dismount only when stopped – falling off can kill.

DANGER! At all times ensure that the PTO shaft guard is in position, securely fitted and in good condition and that the tractor PTO shaft shield is fitted.

CAUTION! Replace the PTO shaft guard if any of the following are evident:- guard cracked or damaged any part of the PTO shaft exposed. Ensure the PTO shaft guard is free to rotate and the anti-rotation chains are securely fitted and effective.

WARNING! Ensure that the correct guards are properly fitted to the machine and tractor at all times and check that they are in good condition. Ensure you have the correct guards fitted for the type of operation being performed. Missing or damaged guards must be replaced immediately.

DANGER! **AVOID WIRE.** It can be extremely dangerous if wire catches in the blades of the machine, and every care must be taken to ensure this will not happen. Inspect the working area before commencing. Remove all loose wire and obstructions and clearly mark those that are fixed so that you can avoid them. Any unusual noise from the cutting unit area indicates that the blades may have been fouled by an obstruction. A visual indication that wire has become entangled may be a sudden movement of the vegetation ahead of the machine. In any such event STOP the tractor engine INSTANTLY. On no account move the machine until blades have completely stopped. When the machine has stopped inspect it and remove any obstruction that may be present. If working under a raised machine ensure that it is safely supported. Before working on the machine always stop the tractor engine and remove the ignition key.

SAFETY

- WARNING!** While the tractor is running all personnel should keep well clear of the area around the machine as there are numerous crushing, shearing, impact dangers caused by the machine operation.
- DANGER!** Do not operate with wings raised off the ground. Operating with the wings raised exposes the blades and can cause objects to be thrown and there is also danger of entanglement in or being hit by rotating blades.
- DANGER!** Do not work under a wing in the raised position unless it is supported on blocks or propped. A sudden or inadvertent fall by one of these components could cause serious injury or even death.
- DANGER!** These machines are capable under adverse conditions of throwing objects great distances at high velocity. CHECK the blades for wear and the attachment bolts for tightness every day during work .A few moments whenever the machine is stopped, e.g. whenever removing obstructions, will help reduce blade wear or loss.
- DANGER!** Keep your forward speed to a level appropriate to the operating conditions. High-speed manoeuvres are very dangerous, particularly on uneven ground where there is risk of overturning.
- DANGER!** Keep a careful watch for passers-by who may inadvertently get in the way of cut material being ejected from the machine. These machines are capable under adverse conditions of throwing objects great distances at high velocity. Stop the blades until all people are well clear.
- WARNING!** Extreme care should be taken when operating near loose objects such as gravel, rocks, wire, and other debris. Inspect the area before mowing. Foreign objects should be removed from the site to prevent machine damage and/or bodily injury or even death. Any objects that cannot be removed must be clearly marked and carefully avoided by the operator. Stop mowing immediately if blades strike a foreign object. Repair all damage and make certain the blade and carrier are still balanced before resuming cutting operations.
- WARNING!** Transport the machine only at safe speeds. Serious accidents and injuries can result from operating this equipment at unsafe speeds
- DANGER!** When the wings are folded for transport, the centre of gravity is raised and the possibility of overturn is increased. Turn slowly and with extra care on hillsides. Overturning the mower could cause the mower to overturn the tractor and vice versa. Never fold wings on a hillside, the mower may overturn
- WARNING!** Do not transport unless wings are well secured in the transport position. Wings that are not well secured can fall during transport, causing serious damage to the tractor and mower and possibly causing the operator or passers by to be injured or killed.
- WARNING!** Release hydraulic pressure from the rams before attempting maintenance. Lower the machine to the ground and lower the wings or securely block up, disengage the PTO and turn off the engine.
- DANGER!** Do not operate this Equipment with hydraulic oil leaking. Oil is expensive and its presence could present a hazard. Do not check for leaks with your hand! Use a piece of heavy paper or cardboard. High-pressure oil streams from breaks in the line could penetrate the skin and cause tissue damage including gangrene. If oil does penetrate the skin, have the injury treated immediately by a physician knowledgeable and skilled in this procedure.

SAFETY

WARNING! Periodically inspect all moving parts for wear and replace when necessary with authorised service parts. Look for loose fasteners, worn or broken parts, and leaky or loose fittings. Make sure all pins have cotter pins and washers. Serious injury may occur from not maintaining this machine in good working order.

WARNING! Never un-couple the machine without using the hitch support jack. The hitch is very heavy. Attempting to lift the hitch without using the jack could cause strains. Allowing the hitch to fall suddenly and unexpectedly could result in crushing injury. Use the support jack for lifting the mower only. Overloading the jack can cause failure with possible serious bodily injury or even death.

WARNING! Never attempt to lubricate, adjust, or remove material from the Implement while it is in motion or while tractor engine is running. Make sure the tractor engine is off before working on the Implement.

Emergency Stop

To stop the blades in an emergency use the tractor stop control. The use of the tractor stop control must only be done in an emergency. Its use to stop the machine can cause damage. After an emergency stop of the machine; ensure that the PTO is disengaged before restarting the tractor.

Safety Decals

Safety decals are located on various points of the machine. They can be identified by the yellow upper panel depicting the hazard, and the lower white panel indicating means of avoidance or precautions to be taken. These decals have no text. It is essential that all operators and personnel associated with the machine fully understand their meanings, which are shown on the following pages.

Any safety decals that are missing should be replaced at the earliest possible opportunity.

ELECTRICAL & FIRE HAZARD

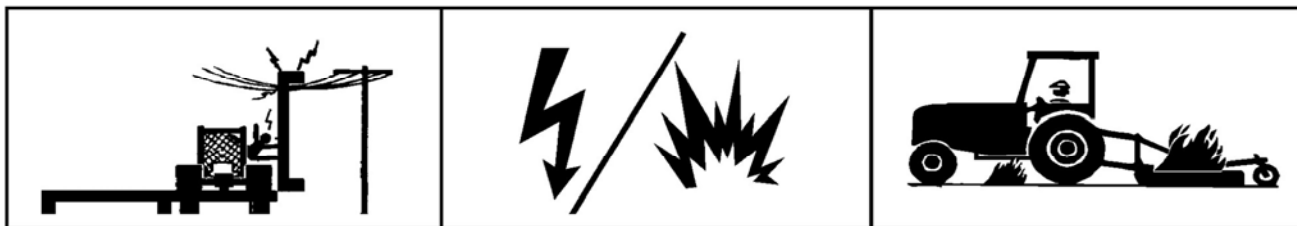

Wing contacting
Overhead Power Lines.

Strike and explosion hazard.
Blades contacting power or gas lines.

Do not operate near fires.
Keep mower deck clear of debris.

⚠ DANGER

To avoid serious injury or death from electrical contact when working near Electrical Power Lines, Gas Lines and Utility Lines:

- **INSPECT** mowing area for overhead or underground electrical power lines, obstructions, gas lines, cables and Utility, Municipal, or other type structure.
- **KEEP** all raised wings at a 3m (10 feet) or greater distance from all power lines and overhead obstructions.
- **DO NOT** allow mower to contact with any Utility structures or obstructions.
- **CONTACT** the Utility Company to identify locations of utility lines in the area.

FIRE PREVENTION GUIDELINES while Operating, Servicing, and Repairing Mower and Tractor to reduce equipment and grass fire Risk:

- **EQUIP** Tractor with a **FIRE EXTINGUISHER**
- **DO NOT OPERATE** mower on a tractor equipped with under frame exhaust.
- **DO NOT SMOKE** or have open flame near Mower or Tractor
- **DO NOT DRIVE** into burning debris or freshly burnt area
- **AVOID FIRE IGNITION** by not allowing mower blade to contact solid objects like metal or rock.
- **ADJUST SLIP CLUTCHES** to avoid excessive slippage and clutch plate heating.
- **CLEAR** any grass clippings or debris build up around mower drivelines, slip clutches, and gearboxes.
- **SHUT OFF ENGINE** while refuelling.

SAFETY DECALS

In addition to company branding and model identification the following safety decals are displayed – familiarise yourself with, and heed the messages they state, they are there for your safety and guidance. If any of the safety decals go missing or become damaged beyond a readable state they should be replaced at the earliest possible opportunity.



WARNING!
Avoid fluid escaping under pressure. Consult technical manual for services procedures.



WARNING!
Shut off engine and remove key before performing maintenance or repair work.



WARNING!
Danger – flying objects keep safe distance from the machine as long as the engine is running.



WARNING!
Check all nuts are tight every 8 hours.



WARNING!
Stay clear of mower blade as long as engine is running.



WARNING!
Carefully read operator's manual before handling this machine. Observe instructions and safety rules when operating.



WARNING!
Stay clear of swinging area of implements.

TRACTOR ATTACHMENT

Fit the machine to the tractor in the standard way, ensuring the correct match of linkage (*category 2*). Check that the top link is in good order and the threads are well lubricated. Use stabilisers to eliminate any sideways sway.

Before lifting the machine with the tractor linkage you should ensure there is sufficient front weight to keep the front wheels in contact with ground - This is vital for both safe transportation and stability when turning on sloping ground.



It is essential to ensure that the tractor drawbar cannot foul the PTO shaft, we advise to remove it altogether if there is any doubt.

PTO SHAFT

Before fitting the PTO for the first time, it may be necessary to adjust the length. There should be maximum engagement of the sliding tubes without bottoming at the shortest operation position. To check, first connect the mower to the tractor. Pull the PTO shaft apart and connect to the tractor PTO output shaft and the gearbox input shaft. Hold the half shafts next to each other in the shortest working position. If necessary, shorten the inner and outer guard tubes equally (*Fig. 1*). Shorten the inner and outer sliding profiles by the same length as the guard tubes. File all sharp edges and remove burrs. Grease the sliding profiles.

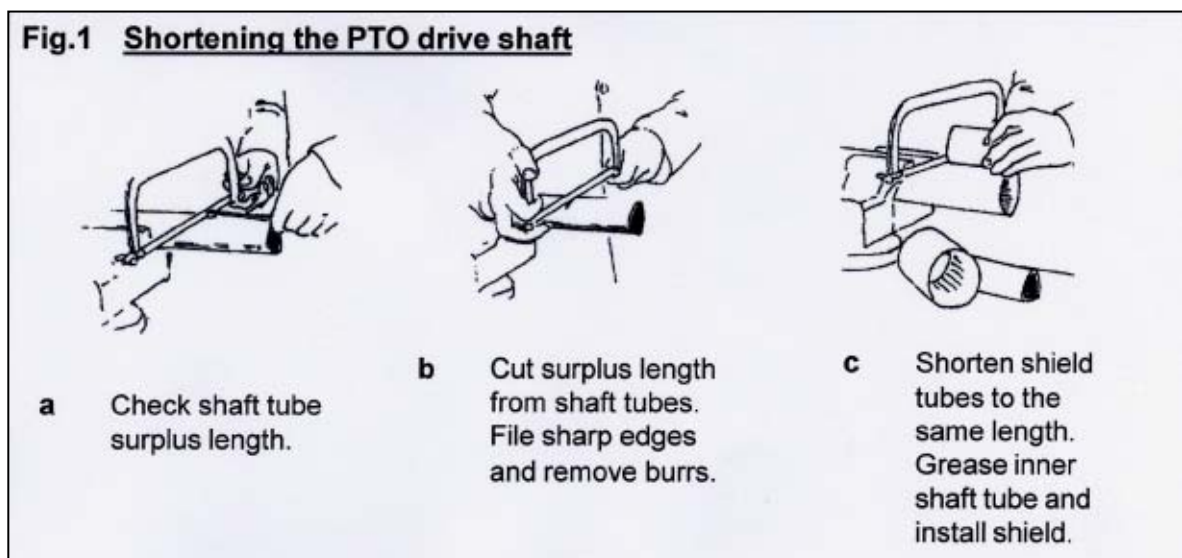

To fit the PTO, first clean and grease. Press pins on the yoke and simultaneously push the PTO drive shaft onto PTO shaft of the tractor until pins engage.

The PTO shaft is fitted with a non-rotating safety guard. It should be secured to the machine and tractor with the two retaining chains provided.

Connect the hydraulic hose to a single acting service with a dump facility. This is important to allow the wings to be able to follow the ground contours.

Connect the top link and adjust to ensure there is some slack in the wire ropes, before raising the machine.

Raise the parking stands (*Fig. 2*) and secure locking pin.

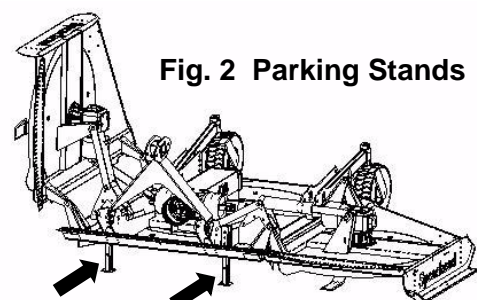

SETTING UP THE MACHINE

Height

To alter the height of cut; raise the machine until the wheels are clear of the ground, remove pin 'A' (Fig. 3) adjust the wheel arm height position and replace pin 'A', gently lower the machine until the wheel contacts the ground. Fine adjustment can be made by moving the spacers 'B' on the wheel fork to above or below the wheel arm. Now adjust the height of the tractor link arms so the front of the mower 'C' is 25mm (1") higher than the rear.

The top link must be adjusted to ensure the wire ropes are slack, so the machine can follow undulating ground fore and aft, but still allow the machine to lift when the tractor link arms are fully raised.

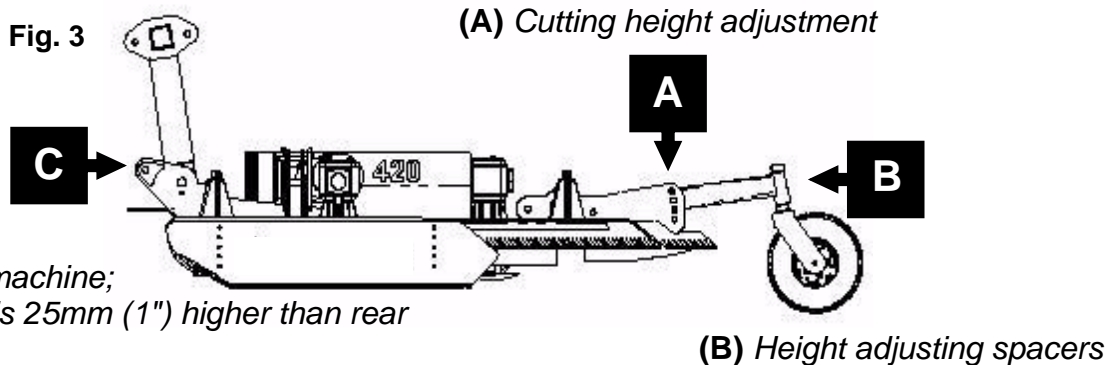

Wings

Unfolding the wings if the machine is in the transport position, first pressurise hydraulic rams before releasing the transport locking bars (Fig. 4), lower both wings by releasing hydraulic pressure, leaving tractor spool in float position (Fig. 5).

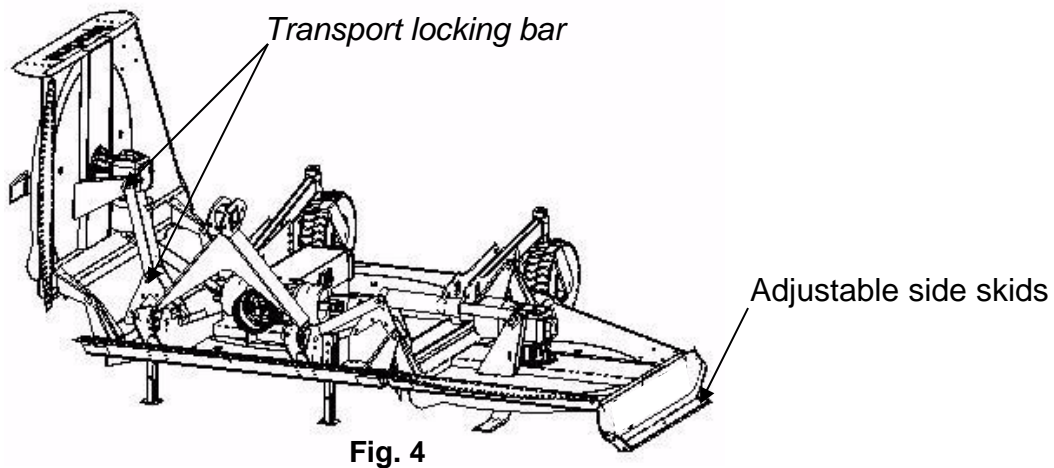

Levelling the wing cutting height (L/H and R/H)

With the wings lowered, adjustable skids alter cutting height, these should be set to maintain minimum cutting height 12mm (1/2") above the centre blades. If wings are fitted with the optional wheels, the skids should be raised above the ground and the cutting height controlled by height setting of the wheels.

NOTE:

To achieve a level cut with the wing wheels, they need to set lower than the centre wheels.

OPERATION

Once ready for work with the wings unfolded, raise the mower clear of the ground and slowly engage the PTO with the tractor engine at low revs to prevent shock damage to the machine. Slowly increase the engine revs to achieve the recommended PTO speed of 1000RPM. As indicated by the decal on top of the centre guard and not the number of splines on the PTO shaft. Lower the machine onto the ground, select a sensible forward speed bearing in mind the density of growth, terrain, and available horsepower, and proceed to work. If at any time serious vibration occurs, **stop the engine immediately and check the blades, following all safety precautions.**

The quality of finish produced will primarily be determined by the forward speed, i.e. a slow speed will produce a high quality of cut, where as faster forward speeds are used when high output is first priority.

When in work, always ensure the hydraulic spool valve that operates the folding of the wings is in float position to enable the wings to freely follow all contours of ground (*Fig. 5*).

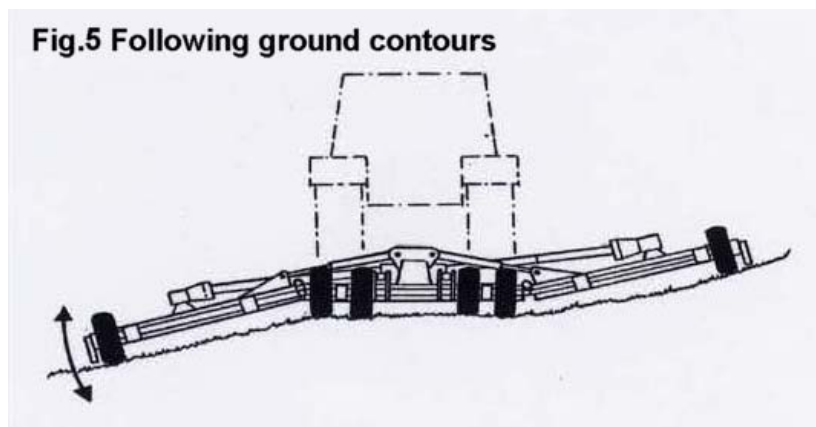

Whilst mowing it is possible to continue working when turning the machine on the headlands, however we recommend the machine is slightly raised to prevent the skids marking the ground and reduce wear on the skids.

When operating in confined areas it is possible to cut going backwards, but it is advisable to slightly raise the machine, particularly if in scrub, where there is the risk of hitting hidden solid obstacles obscured by dense undergrowth.

Always exercise particular care when operating over uneven ground surfaces. Do not allow the blades and blade holder to frequently hit the ground.

Do not allow debris to build upon the cutting decks in dry conditions, as this can be a fire hazard, in wet conditions it will place unnecessary strain on the machine and may foul the drive shaft causing damage.



WARNING! Never run the machine with the wings in the raised position; this is not only extremely dangerous, but will also result in serious damage to the driveline.

Options

- An extra two wheels are available for the wings to improve contour following on uneven ground and reduce wear on the skids.
- Three blades per rotor (*standard 2*) to improve cutting and mulching.
- Lighting kit.

TRANSPORTATION

First disengage the PTO drive and half raise the machine, fold the wings fully upright and secure rams with transport locking bar (Fig. 6). Never transport along public highways with the wings only supported by the hydraulics.

Fig. 6
Transportation Position

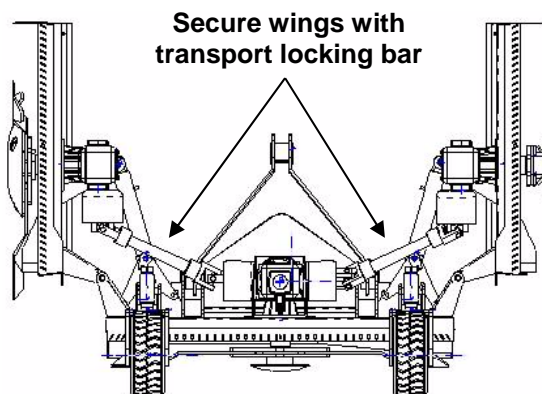

Always observe all Public Highway Regulations concerning the towing of implements and machines. Ensure a registration plate that matches that of the towing vehicle is correctly displayed and that rear lighting is fitted, working and visible.



WARNING! Avoid transporting the machine at high speeds especially over rough ground. Maximum speed on the highway – 20mph (30kph).

MACHINE PROTECTION

To prevent gearbox damage all rotors are protected by slip clutches fitted to each of the three rotor gearboxes. When cutting in extreme conditions where stumps, rocks and other such solid objects are likely to be found it is recommended that the operator reduces the engine revs to allow the blades to pivot more easily when striking solid objects, and proceed with caution.

The clutch settings should not be altered without first referencing the information stated in the Service and Maintenance Section. Never over-tighten the pressure springs on the slip clutches (Fig. 7) as this could result in severe damage to the gearbox and drive lines, as well as invalidating the warranty.

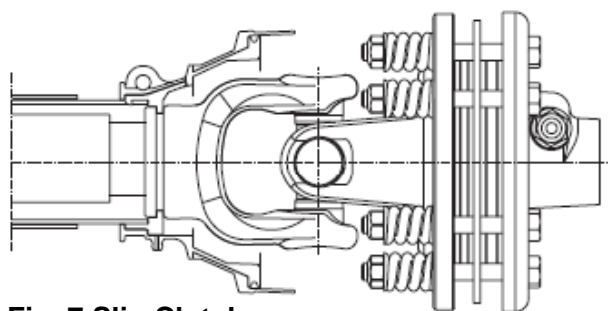

Fig. 7 Slip Clutch

WARNING: If the machine has been laid up for any length of time, there is a risk of the clutch plates rusting and seizing together. Never operate the machine in this condition, as there will be no protection to the driveline and gearboxes against shock loading.

To free the clutch plates first slacken all pressure spring bolts and run up the machine for a short period, deliberately try to cause the clutch to slip. Finally re-tighten the tension spring bolts to their original length, taking great care not to over-tighten. For additional information refer to 'Slip Clutch Settings' in the Maintenance Section.

If in any doubt, consult McConel Service Department or your local Dealer for further advice.

SERVICE & MAINTENANCE



WARNING! Never attempt to carry out any servicing or maintenance of the machine without first disengaging the PTO and switching off the tractor engine.

On initial delivery of your machine check the Dealer has completed the P.D.I form and Online Warranty Registration.

SAFETY FIRST

- ▲ Never leave the tractor seat without first disengaging the PTO and stopping the engine.
- ▲ Ensure all rotating parts have stopped turning.
- ▲ Never attempt any repairs, maintenance, service or any other checks with the machine carried on the tractor hydraulics.
- ▲ Always fully lower to the ground, or securely prop the machine on substantial servicing stands.
- ▲ Always replace all guards and retaining chains after servicing and/or maintenance.

It is imperative that the following checks are carried out in order not to invalidate your warranty; these must be performed **before the first operation, after the first hour, then after 4 hours.**

These checks are:

1. Wheel nuts and tyre pressure (*40psi*).
2. Gearbox bolts, including the splitter box.
3. Retaining bolts on the drive shafts.
4. Grease all points including drive shaft tubes.
5. **After the first 50 hours drain and replace the gearbox lubrication.** Replace with liquid grease (NLGI 000).
6. All other nuts and bolts.

Splitter Box Oil Plug Locations

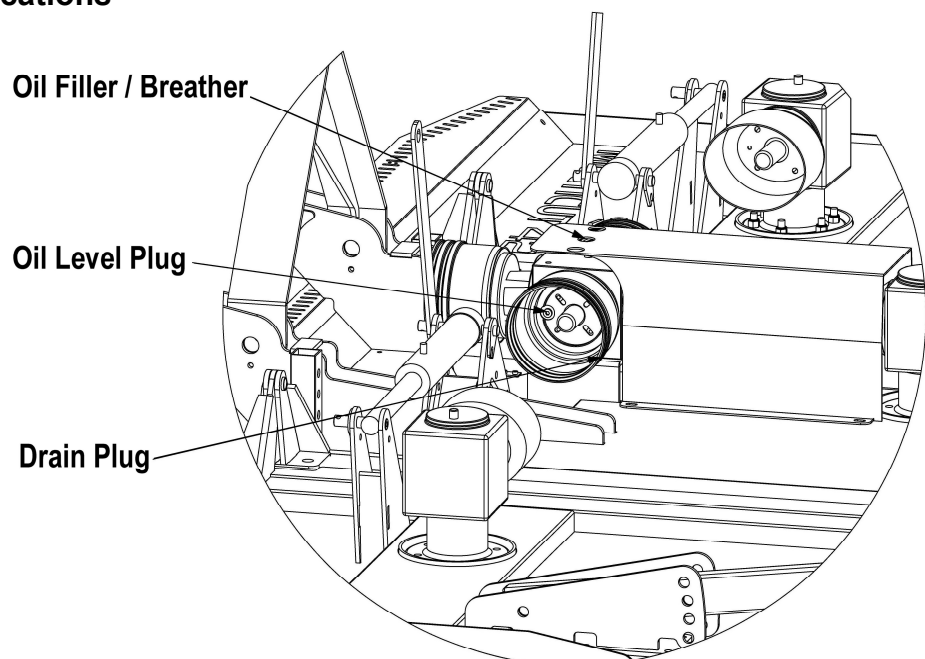

Daily Checks

- Grease all points.
- Check bolts are tight on all gearboxes.
- Check condition of blades and blade bushes; ensure all retaining bolts are fully tight.
- Check wheel nuts are tight.
- Check tyre pressures – 40 P.S.I.
- Check gearbox lubrication, replenish as necessary to the correct level line on the dipstick, provided with each gearbox.

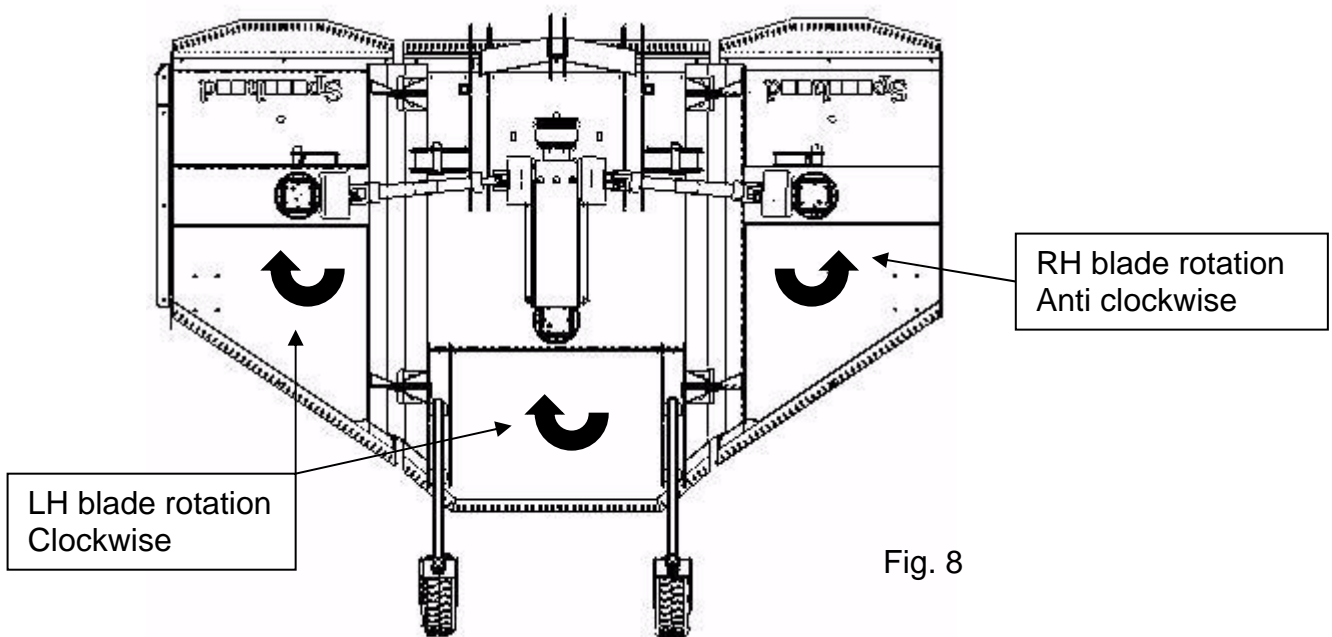

Lubrication points

- A** Wing rams
- B** Wheel stem grease points
- C** Wheel bearings
- D** Wing hinges
- E** Input PTO shaft
- F** Wing PTO shafts
- G** Centre PTO coupling
- H** Headstock

Primary Input Shaft Lubrication (8 hourly)

- For maximum life and performance, the UJ must be greased regularly. Lubricate with the driveline - *up to 6 pumps of grease may be required.*

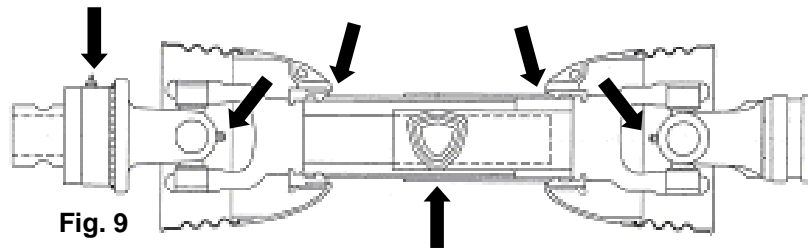

- The metal drive tubes must be greased to enable them to telescope properly.
- Shielding is subject to damage from abuse and weathering. Replace all damaged components and all shielding removed during maintenance.
- Do not use PTO adapters drivelines. Replace special clamp bolts only with genuine OEM parts, periodically check tightness of nuts.
- Dismantle and clean the main input PTO shafts sliding surfaces and re-grease; failure to do this will result in serious damage to the gearboxes.
- Grease all universal joints; If under-greased the joint will soon fail.
- Grease the wing drive shaft tubes.
- Lubricate the retaining collar on all the drive shaft guards (*Fig. 9*).
- Grease PTO inner tube and push pins (*Fig. 9*).
- Check all bolts are fully tightened to the correct torque – *Refer to chart below.*

Torque Settings Chart

Figures stated are recommended maximum settings only

Size	Tensile strength	Description	Torque Setting
M16	8.8	Rotor gearbox bolts	280Nm.
3/4 UNC	8.8	Splitter gearbox	280Nm.
M24	8.8	Blade bolts	950Nm.
M24	12.9	Axle bolts	1500Nm.
M14		PTO clamp bolt	150Nm.
		Wheel nuts	270Nm.

Regular Maintenance Tasks

- Check there are no 'wrappings' of string, plastic, grass or other debris between rotor boss and gearbox oil seal.
- Inspect gearbox seals for leaks.
- Clear grass and other debris from the deck.
- Regularly check the rotor boss retaining castle nut for tightness. First remove the split pin, select the correct size socket in 3/4" drive and fully tighten the nut. When replacing the split pin, do not slacken the nut to align the hole, always tighten. Failure to regularly check this nut will result in serious wear to hub, which is expensive to repair.
- **It is imperative that all gearbox bolts are regularly checked and kept 'very tight' - with a new machine there will be an initial 'bedding in' period during which frequent checking of the bolt tightness is of vital importance.**

Blade Maintenance



Caution! When carrying out maintenance work on or near blades be careful of free-swinging blades which can 'over-center' and fall. It is recommended that protective clothing including hardhat, safety gloves, and goggles are worn at all times.

The blades can be re-sharpened by grinding the cutting edges, care must be taken that the blades are of the same weight and length after grinding. Do not overheat when grinding as this will affect the hardness of the blades. All the blades are free swinging and swivel on hardened steel bushes, which are replaceable. When replacing blades, it is important that blades are replaced in sets, in order to retain balance of the rotor. Bushes must be replaced when new blades are fitted.

If the blades are showing any signs of severe wear, damage or cracking, they must be replaced immediately. Never attempt to weld the blades, as this will make them very brittle and thus extremely dangerous. Do not take risks with the cutting blades - if in doubt, replace them.

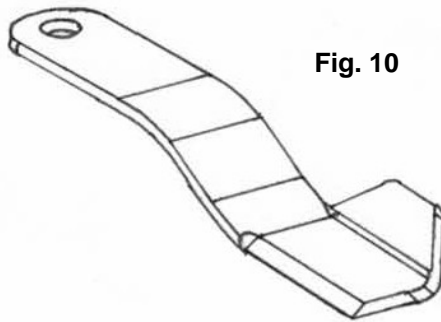

Fig. 10

Cutting Blade
LH Blade illustrated

Slip Clutch Maintenance & Settings

Check the condition of the friction discs before use and following periods of storage. Release the tension from the springs and turn the clutch body while holding the inner PTO hub stationary, if unable to turn freely strip down clutch and free off seized parts ensuring that all traces of rust are removed. Rebuild and adjust the spring compression to the original setting.

Following seasonal use, unload the spring tension and store clutch assembly in a dry place. Check condition of friction linings and reset spring compression to original height before use.

Should the assembly overheat due to frequent or prolonged clutch slipping, dismantle for inspection. The original thickness of the lining is 3.0 mm, replace them when worn to 2.0 mm. Clean up all contact surfaces and replace any damaged components before assembly.

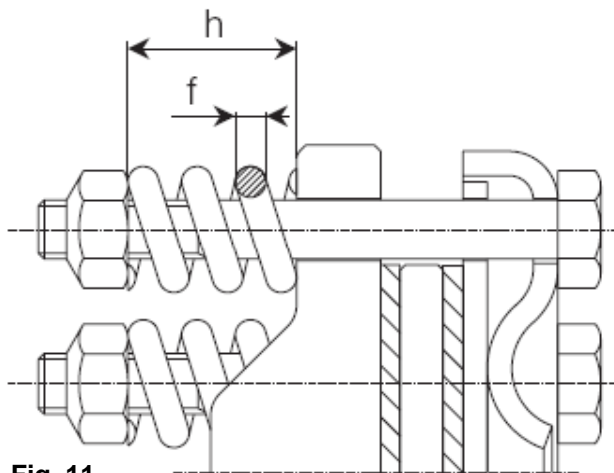

Fig. 11



Fig. 11 (h)	Fig. 11 (f)	Position	Setting	Machine	Part no
33.2 mm	7mm	Centre	1000Nm	SR420	5770409
33.2 mm	7mm	Wing	1000Nm	SR420	5770410



WARNING! Slip clutches are fitted in order to protect the gearboxes. If the blades strike a large obstacle they can suffer damage or break – avoid these conditions wherever possible.

Skids

When operating on abrasive soils, particularly in stubbles and similar conditions with thin ground cover, excessive skid wear may be expected. To provide extra protection and to prolong life of the skids, special hard facing rods are available.

Wheels



WARNING! Heavy duty industrial tyres have been fitted the machines for convenience of tyre removal, the wheel rims are of the split rim type.

When removing the wheels only remove the five larger hub nuts. Never undo the smaller outer nuts (*which are painted red for danger*) when removing the wheel.

The outer nuts must not be loosened until the valve has been removed and the inner tube is entirely deflated. **Then, and only then** may the outer bolts be loosened. Failure to observe these precautions could seriously injure or even result in loss of life.

If in any doubt consult a tyre repair specialist or the McConnel Service Department.

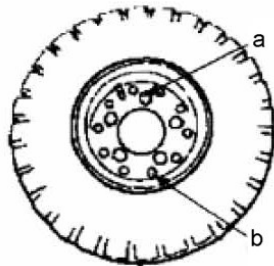

Wheel

- a. Hub Nuts
- b. Outer Nuts (painted red)

Storage

Before storage, thoroughly wash the machine removing all traces of grass and dirt. Great care must be taken when washing with high-pressure hoses - do not hold the water jet close to the paint work. Use steam cleaners with caution and be sure to remove all detergents to avoid any discoloration or damage to the paintwork.

Lubricate all grease points until fresh grease shows. Liberally apply 'used' engine oil along the whole length of the hinges of each wing section. The centre clutch coupling and wing shafts must be removed and stored under cover. Smear grease on the chrome ramrods for protection.

After Storage

Disassemble clutches and with an emery cloth remove all traces of rust on the metal clutch plates. Check condition of the friction plates, if there are any sign of over heating, wear or cracking, they should be replaced. Do not attempt to use the machine with damaged slip clutch plates.

Reassemble the clutch units and tighten the bolts to achieve the correct spring length. Do not over tighten or the clutches will not work.

Check condition and pressure of the tyres then follow the maintenance procedure covered in the servicing part of this manual. Pay particular attention to the condition of guards and blades.

Remember the *SR420 Rotary Cutter* is designed to withstand the most rigorous conditions and, with a little care and attention, will give many years of trouble free service. So as not to invalidate the warranty and to avoid problems, use only genuine parts and make sure the machine is not driven at a speed in excess of 1000rpm on the PTO.

TROUBLESHOOTING GUIDE

Broken or damaged blades

1. *Raise cutting height to avoid striking the ground.*
2. *Remove or avoid obstacles such as rocks.*
3. *Check rotor speed.*
4. *Ensure a steady feed into drive (Do not snatch the PTO).*
5. *Fit optional stump jumpers.*

Damaged blade holder

1. *Refer to the above.*
2. *Failure to keep tight centre retaining nut.*

Damage gearboxes

1. *Seized slip clutch.*
2. *Telescopic shafts bottoming out.*
3. *Engaging drive with too much power / revs.*
4. *Lack of grease on sliding tubes of drive shaft.*

Damage to PTO shaft

1. *Seized slip clutch.*
2. *Telescopic tube bottoming out.*
3. *Engaging drive with too much power / revs.*
4. *Turning too sharp.*
5. *Not enough overlap.*
6. *Lack of grease.*
7. *Build up of Debris under drive shaft.*

Gearbox overheating

1. *Incorrect oil level.*
2. *Incorrect grade of oil.*
3. *Incorrect operating speed.*
4. *Machine overloaded.*
5. *Build up of materials around the gearbox reducing air circulation.*

Slip clutches overheating

1. *Machine overloaded.*
2. *Incorrect operating speed.*
3. *Incorrect setting.*
4. *Blades hitting the ground.*

Oil leak from gearbox

1. *Damaged shaft seal check for foreign matter (wire, string etc.).*
2. *Faulty breather.*
3. *Damaged gasket.*
4. *Incorrect oil level.*

Metal fatigue on frame

1. *Too fast a traveling / operating speed for conditions.*
2. *Wings not floating i.e. following the ground contours (check tractor spool).*
3. *Used in a manner or condition contra to its intended purpose.*

Excessive skid wear

1. *Fit optional wheel kit to wings and set skids above the ground.*



McConnel Limited, Temeside Works, Ludlow, Shropshire SY8 1JL. England.
Telephone: 01584 873131. Facsimile: 01584 876463. www.mcconnel.com