

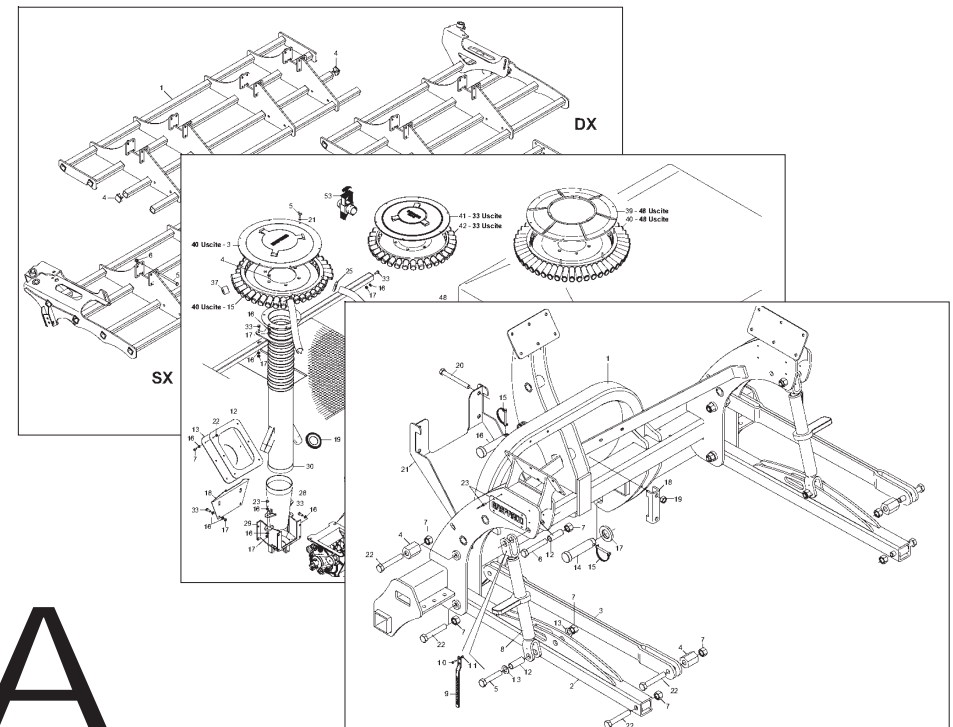

GASPARDO

MASCHIO GASPARDO S.p.A.



PRIMAVERA

Cod: G19531020 2009-07

- *) Valido per Paesi UE
- *) Valid for EU member countries
- *) Valable dans les Pays UE
- *) Gilt für EU-Mitgliedsländer
- *) Válido para Países UE

IT PARTI DI RICAMBIO
EN SPARE PARTS
DE ERSATZTEILE
FR PIÈCES DÉTACHÉES
ES PIEZAS DE REPUESTO

PARTI DI RICAMBIO**SPARE PARTS****ERSATZTEILE****PIECES DÉTACHÉES****RESPUESTOS**

Le ordinazioni delle parti di ricambio vanno fatte presso i nostri concessionari di zona e devono essere sempre corredate dalle seguenti indicazioni:

- **Tipo, modello e numero di matricola dell'attrezzatura.** Tali dati sono stampigliati nell'apposita targhetta di cui è dotata ogni attrezzatura.

- **Numero di codice della parte richiesta** rilevabile dal catalogo ricambi.

- **Descrizione del particolare e quantità richiesta.**

- **Numero della tavola.**

- **Mezzo di trasporto.** Nel caso questa voce non sia specificata, la Ditta Costruttrice, pur dedicando a questo servizio una particolare cura, non risponde di eventuali ritardi di spedizione dovuti a cause di forza maggiore.

Le spese di trasporto si intendono sempre a carico del destinatario. La merce viaggia a rischio e pericolo del committente anche se venduta franco destino.

NOTA: Il termine **(Dx) Destro** o **(Sx) Sinistro** della macchina o di parti di essa, è inteso guardando la macchina dalla parte posteriore. Le eccezioni saranno indicate.

Orders must be transmitted through our area dealers and should always include the following indications:

- **Type, model and serial number of the machine.** *These data are punched on the data plate with which every implement is equipped.*

- **Code number of the required spare part.** *This will be found in the spare parts catalogue.*

- **Description of the part and required quantity.**

- **Table number.**

- **Means of dispatch.** *If this item is not indicated, the Manufacturer, while dedicating particular care to this service, shall not be held responsible for delays in delivery caused by cases of force majeure.*

Transport expenses shall always be at the consignee's charge. The goods travel at the purchaser's risk and peril even when sold ex destination.

NOTE: *The symbols (Dx) right and (Sx) left, concerning the machine or single parts of it, are referred, as in the figure, to a rear view of them. Exceptions will be indicated.*

Die Bestellungen müssen bei unseren Gebietshändler aufgegeben werden. Bei der Bestellung sind stets die folgenden Angaben zu machen:

- **Typ, Modell und Serien-Nummer des Geräts.** Diese Daten stehen auf dem Typenschild, mit dem jedes Gerät versehen ist.

- **Artikel Nr. der erforderlichen Ersatzteile.** Diese stehen im Ersatzteil-Katalog.

- **Beschreibung des Ersatzteils und die erforderliche Stückzahl.**

- **Tafelnummer.**

- **Versandmittel.** Wenn dieser Punkt nicht spezifiziert wird, haftet die Herstellerfirma nicht für etwaigen Lieferverzug aufgrund höherer Gewalt, auch wenn er diesen Service besonders aufmerksam abwickelt.

Die Frachtkosten gehen dagegen immer zu Lasten des Empfängers. Die Ware reist auf Gefahr und Risiko des Auftraggebers, auch wenn frei Haus Verkauft vereinbart worden ist.

N.B.: Die Merkzeichen **(Dx) rechts** und **(Sx) links** betreffen eine rückwärtige Aussicht der Maschine oder Teile von ihr (siehe Bild). Ausnahmen werden gezeigt.

Les ordres doivent être effectués auprès de nos concessionaires de zone en précisant les indications suivantes:

- **Type, modèle et numéro de série de la machine.** *Ces données sont gravées sur la plaque d'identification de chaque outil.*

- **Numéro de code de la pièce détachée** *indiqué sur le catalogue des pièces détachées.*

- **Description de la pièce et quantité requise.**

- **Numéro de plan.**

- **Moyen d'expédition.** *Si cette rubrique n'est pas indiquée, le Constructeur, bien que soucieux de ce service, ne répond pas des retards d'expédition pour des causes de force majeure.*

Les frais de transport sont toujours à la charge du destinataire. La marchandise voyage aux risques et périls de l'acheteur même si vendue franco de port.

N.B.: *Les références (Dx) droit et (Sx) gauche de la machine ou des parties de la même, est entendue, comme de la figure, en regardant la machine de derriere dans le sens de marche.*

Los pedidos han de efectuarse en nuestros consesionarios de zona y deben incluir siempre las siguientes indicaciones:

- **Tipo, modelo y número de matricula del equipo.** Dichos datos están impresos en la relativa placa presente en el equipo.

- **Número de código de la parte requerida** presente en el catálogo respuestas.

- **Descripción de la pieza y cantidad requerida.**

- **Numero de ilustración.**

- **Medio de transporte.** En caso que este ítem no esté especificado, el Fabricante, aún prestando la debidas consideraciones para este aspecto, no responde por eventuales retardos de env'o debidos a causas de fuerza mayor.

Los gastos de transporte se consideran siempre a cargo del destinatario. La mercadería viaja bajo riesgo y peligro del comprador, incluso cuando se vende franco destino.

N.B.: La refencia **(Dx) derecha** o **(Sx) izquierda** de la máquina o de sus componentes, se entiende, como en la figura, mirando la máquina por la parte trasera. Se indicarán las excepciones.

Nr. Tav.	Descrizione - Description	Pag.
TAV. 010	Telaio	4
TAV. 020	Telaio posteriore	6
TAV. 030	Segnafile (mod. 400/450)	8
TAV. 040	Impianto oleodinamico telaio-segnafile (mod. 400/450)	10
TAV. 050	Segnafile (mod. 500/600)	12
TAV. 060	Impianto oleodinamico telaio-segnafile (mod. 500/600)	14
TAV. 070	Tramoggia	16
TAV. 080	Dosatore seme	18
TAV. 090	Ruota e Trasmissione	20
TAV. 100	Cambio	22
TAV. 110	Trasmissione soffiante	24
TAV. 120	Soffiante	26
TAV. 130	Azionamento oleodinamico soffiante dipendente da trattore	28
TAV. 140	Telaio elementi operatori	30
TAV. 150	Elementi operatori a molla	32
TAV. 160	Elementi operatori a disco doppio	34
TAV. 170	Erpice copriseme	36
TAV. 180	Doppio ruotino premiseme	38
TAV. 190	Scaletta	40
TAV. 200	Ruotini di profondità	42
TAV. 210	Rompitraccia	44
TAV. 220	Preparatore anteriore	46
TAV. 230	Spianaterra anteriori	48
TAV. 240	Tracciasentieri posteriore	50
TAV. 250	Tabelle ingombro e luci	52
TAV. 260	Alberi cardanici	54

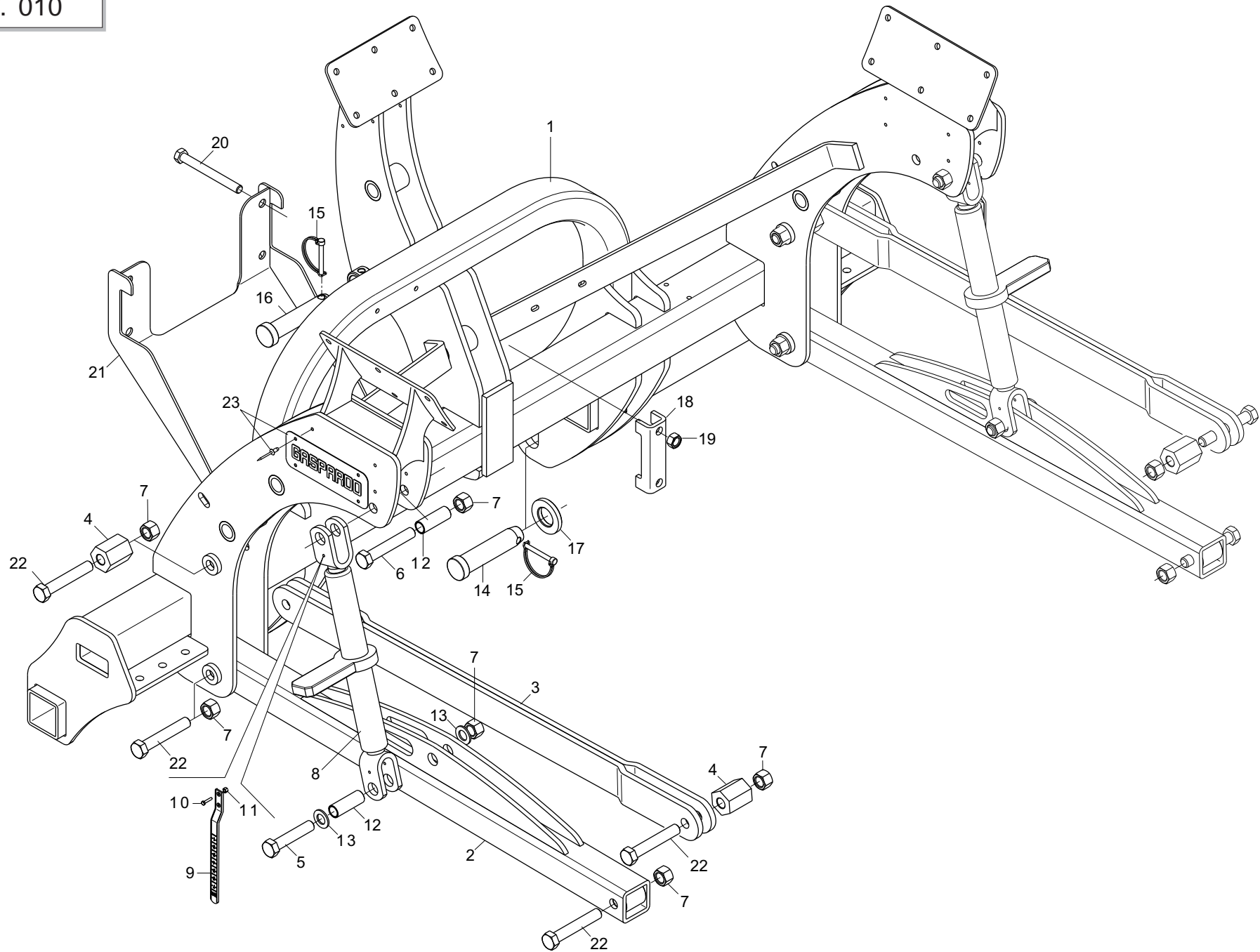

TELAIO

TAV. 010

Pos.	Cod.	Descrizione	Description	Description	Benennung	Descripcion
1	GA7910100	ASS.TEL.SUPP.TRAMOGGIA				
2	G17917781	ASS.BRACCIO LATERALE TELAIO				
3	G17917770	ASS.ASTA PARALLELO				
4	G16072530	DISTANZIATORE	SPACER	ENTRETOISE	DISTANZSTUCK	DISTANCIADOR
5	F01020312	VITE M20X2,5X100 U5737 8.8 ZN	SCREW M20X2,5X100 U5737 8.8 ZN	VIS M20X2,5X100 U5737 8.8 ZN	SCHRA.M20X2,5X100 U5737 8.8 ZN	TORN. M20X2,5X100 U5737 8.8 ZN
6	F01020315	VITE M20X2,5X120 U5737 8.8 ZN	SCREW M20X2,5X120 U5737 8.8 ZN	VIS M20X2,5X120 U5737 8.8 ZN	SCHR. M20X2,5X120 U5737 8.8 ZN	TORN. M20X2,5X120 U5737 8.8 ZN
7	F01230131	DADO M20X 2,5 D982 6 ZN	NUT M20X 2,5 D982 6 ZN	ECROU M20X 2,5 D982 6 ZN	MUTTER M20X 2,5 D982 6 ZN	TUERCA M20X 2,5 D982 6 ZN
8	G17911540	MART*M.L= 700 L= 510 D=25,4	TIE ROD	TRINGLE	SPANNSTANGE	TIRANTE
9	G19003400	ASTA INDICAZIONE PROFONDITA'	DEPTH INDICATING ROD	TIGE INDICATION PROFONDEUR	TIEFENANZEIGESTAB	VARILLA INDICACIÓN PROFUNDIDAD
10	F01020364	VITE M 4X0,7X 20 U5739 8.8 ZN	SCREW 4X20 5739 8.G ZN	VIS 4X20 5739 8.G ZN	SCHRAUBE 4X20 5739 8.G ZN	TORNILLO 4X20 5739 8.G ZN
11	F01230016	DADO M 4X 0,7 D982 8 ZN	NORM.SELF-LOCKING NUT 4 GALVAN	ECROU AUTOB.NOR.4 ZN	SELBSTSP. MUTTER NOR. 4 ZN	TUERCA AUTOB. NOR. 4 ZN
12	G18801960	BOCCOLA 20,25X25 X70	BUSHING 20,25 X25 X70	BOITE 20,25 X25 X70	BsCHSE 20,25 X25 X70	CASQUILLO 20,25 X25 X70
13	F01410124	ROS.M20 21X 37X 3 U6592 ZN	WASHER M20 21X37X3 U6592 ZN	RONDELLE M20 21X37X3 U6592 ZN	SCHEIBE M20 21X37X3 U6592 ZN	ARANDELA M20 21X37X3 U6592 ZN
14	F20100112	PERNO D36 L128 C43 ZN	BOLT D36 L128 C43 ZN	BOULON D36 L128 C43 ZN	BOLTZEN D36 L134 C43 ZN	PERNO D36 L128 C43 ZN
15	F02200573	SPINA SICUR. D. 10X70 ZN	SAFETY PIN D10 L70 ZN	FICHE A DETENTE D10 L70 ZN	EINRASTDTIFT D10 L70 ZN	CLAVIJA DE MUELLE D10 L70 ZN
16	F20100101	PERNO D32 L128 C43 ZN	PIN D32 L128 C43 ZN	BOULON D32 L128 C43 ZN	BOLTZEN D32 L128 C43 ZN	PERNO D32 L128 C43 ZN
17	G18701810	RONDELLA 38X70X10	WASHER 38X70X10	RONDELLE 38X70X10	UNTERLEGSCHIEBE 38X70X10	ARANDELA 38X70X10
18	G13710560	SCONTRO Q 100	FLANGE 'U' SP.8 100 2F16 118	BRIDE 'U' 100 SP.8 2F16 118	ANSCHLAG 'U' 100 SP.8 2F16 118	EL.DE EMPALME 'U' 100 2F16 118
19	F01230084	DADO M16X1,5 D982 6 ZN	SELF LOCKING NUT M16X1,5	ECROU AUTOBL. M16X1,5	SELBSTSPERR.MUTTER M16X1,5	DADO AUTOBL. M16X1,5
20	F01020270	VITE M16X 2X150 U5737 8.8 ZN	SCREW M16X 2X150 U5737 8.8 ZN	VIS M16X 2X150 U5737 8.8 ZN	SCHR. M16X 2X150 U5737 8.8 ZN	TORN. M16X 2X150 U5737 8.8 ZN
21	G17914680	PROTEZIONE TUBI	GUARD	PROTECTION	SCHUTZ	PROTECION
22	F01020317	VITE M20X2,5X150 U5737 8.8 ZN	BOLT M20X2,5X150	VIS M20X2,5X150	SCHRAUBE M20X2,5X150	TORNILLO M20X2,5X150
23	G19701890	TARGA GASPARDO IN BASSORILIEVO				

TAV. 020

Nella versione flottante, con i ruotini, si tolgono le piastrine nr. 17 e si applicano le boccole in dotazione (nr. 23).
Con ruotini ed azoto, permangono le piastrine.

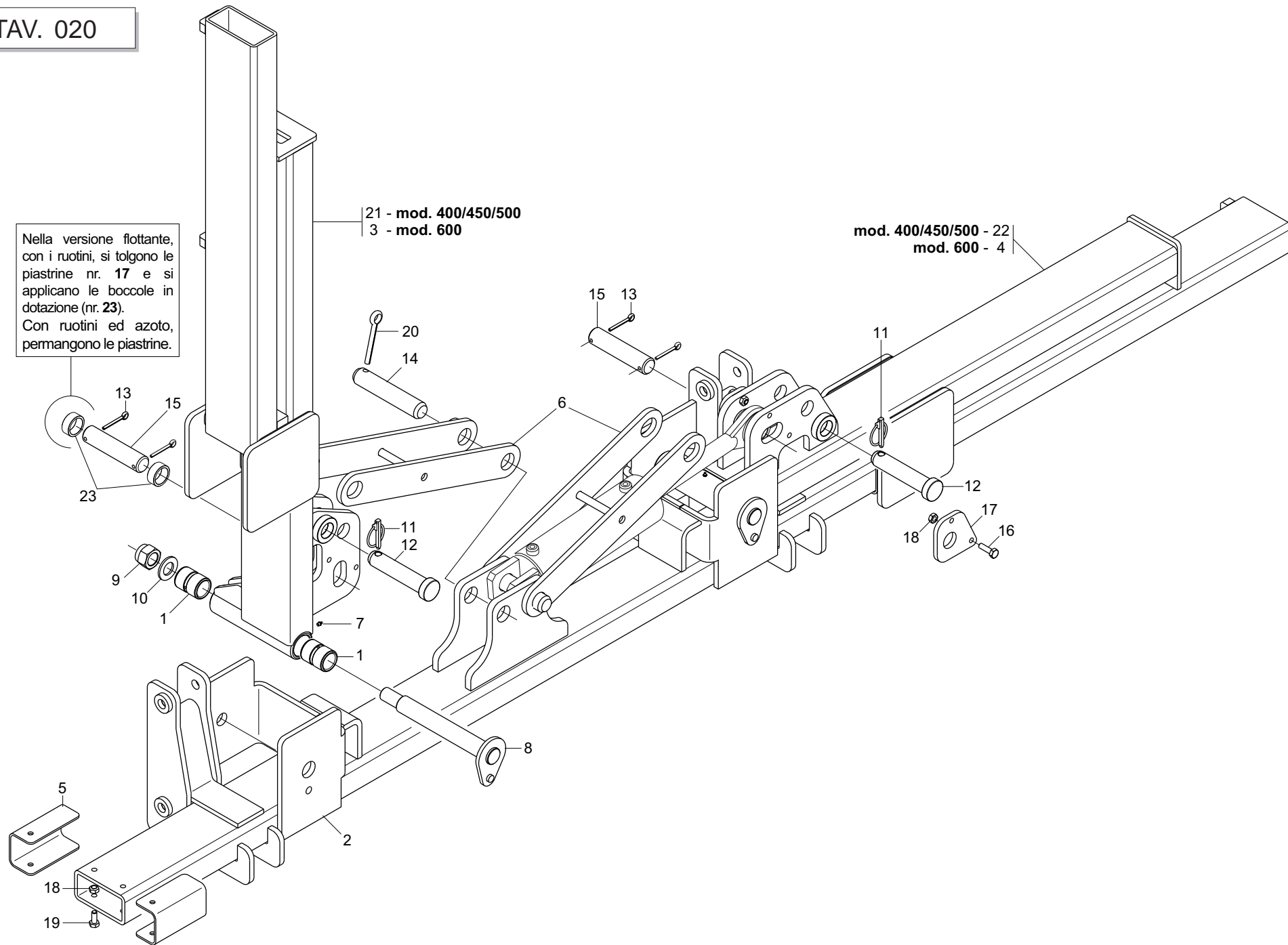

TELAIO POSTERIORE

TAV. 020

Pos.	Cod.	Descrizione	Description	Description	Benennung	Descripcion
1	G15320041	BOCCOLA BRACCIO DIRECTA	DIRECTA ARM BUSHING	BOITE BRAS DIRECTA	BsCHSE ARM DIRECTA	CASQUILLO BRAZO DIRECTO
2	G17911613	ASS.TELAIO CENTRALE POST.				
3	G17910223	BRACCIO PIEGHEVOLE SX				
4	G17910233	BRACCIO PIEGHEVOLE DX				
5	G17914670	INNESTO PER SCORRIMENTO				
6	G17915232	ASS.DI SICUREZZA				
7	F01100011	ING.M 6X1 7663-A 9SMNPB28 ZN	GREASE NIPPLE M6X1 7663-A ZN	GRAISSEUR A BILLES M6X1 7663-A	SCHMIERBUECHE M6X1 7663-A ZN	ENGRAS. DE ESFERAS M6X1 7663-A
8	G17917610	ASS.SPINA ALA LATERALE				
9	F01230150	DADO M27X 3 D982 8 ZN	NUT M27X3 D982 8 ZN	ECROU M27X 3 D982 8 ZN	MUTTER M27X 3 D982 8 ZN	TUERCA M27X 3 D982 8 ZN
10	F01410157	ROS.M27 28X 50X 4 U6592 ZN	WASHER M27 28X50X4 U6592 ZB	RONDELLE M27 28X50X4 U6592 ZB	SCHEIBE M27 28X50X4 U6592 ZB	ARANDELA M27 28X50X4 U6592 ZB
11	F02200507	SPINA SCATTO D. 9 B/83 ZN	SNAP PIN D9 B/83 ZN	FICHE A DETENTE D9 B/83 ZN	EINRASTSTIFT D9 B/83 ZN	CLAVIJA DE MUELLE D9 B/83 ZN
12	F20100101	PERNO D32 L128 C43 ZN	PIN D32 L128 C43 ZN	BOULON D32 L128 C43 ZN	BOLTZEN D32 L128 C43 ZN	PERNO D32 L128 C43 ZN
13	F02200247	COPIGLIA 6X 60 U1336 ZN	SPLIT PIN 6X 60 U1336 ZG	GOUPILLE 6X 60 U1336 ZG	SPLINT 6X 60 U1336 ZG	PASADOR 6X 60 U1336 ZG
14	G16113350	SPINA	PIN ZN	GOUPILLE ZN	BOLZENSTIFT ZN	PASADOR ZN
15	G16410480	SPINA 35X134	PIN 35X134	GOUPILLE 35X134	STIFT 35X134	CLAVIJA 35X134
16	F01020479	VITE M10X 1,5X35 U5739 8.8 ZN	SCREW M10X1,5X35 U5739 8.8 ZN	VIS M10X1,5X35 U5739 8.8 ZN	SCHR. M10X1,5X35 U5739 8.8 ZN	TORN. M10X1,5X35 U5739 8.8 ZN
17	G17913021	LAMA FERMO TELAIO PIEGH.				
18	F01230048	DADO M10X 1,5 D982 8 ZN	NUT AUTOBLOC. M10 ZB	ECROU AUTOBLOC. M10 ZB	SCHEIBE AUTOBLOC. M10 ZB	TUERCA AUTOBLOC M10 ZB
19	F01020472	VITE M10X 1,5X25 U5739 8.8 ZN	BOLT 10X25 5739 8.G GALVANIZED	VIS 10X25 5739 8.G ZN	SCHRAUBE 10X25 5739 8.G ZN	TORNILLO 10X25 5739 8.G ZN
20	F02200272	COPIGLIA 10X 60 U1336 ZN	SPLIT PIN 10 X60 1336 GALVAN.	GOUPILLE 10 X60 1336 ZN	SPLINT 10 X60 1336 ZN	PASADOR 10 X60 1336 ZN
21	G17919320	ASS.BRACCIO PIEGHEVOLE SX 400				
22	G17919330	ASS.BRACCIO PIEGHEVOLE DX 400				
23	G18802050	BOCCOLA 35,25X45X18				

TAV. 030

mod. 400/450

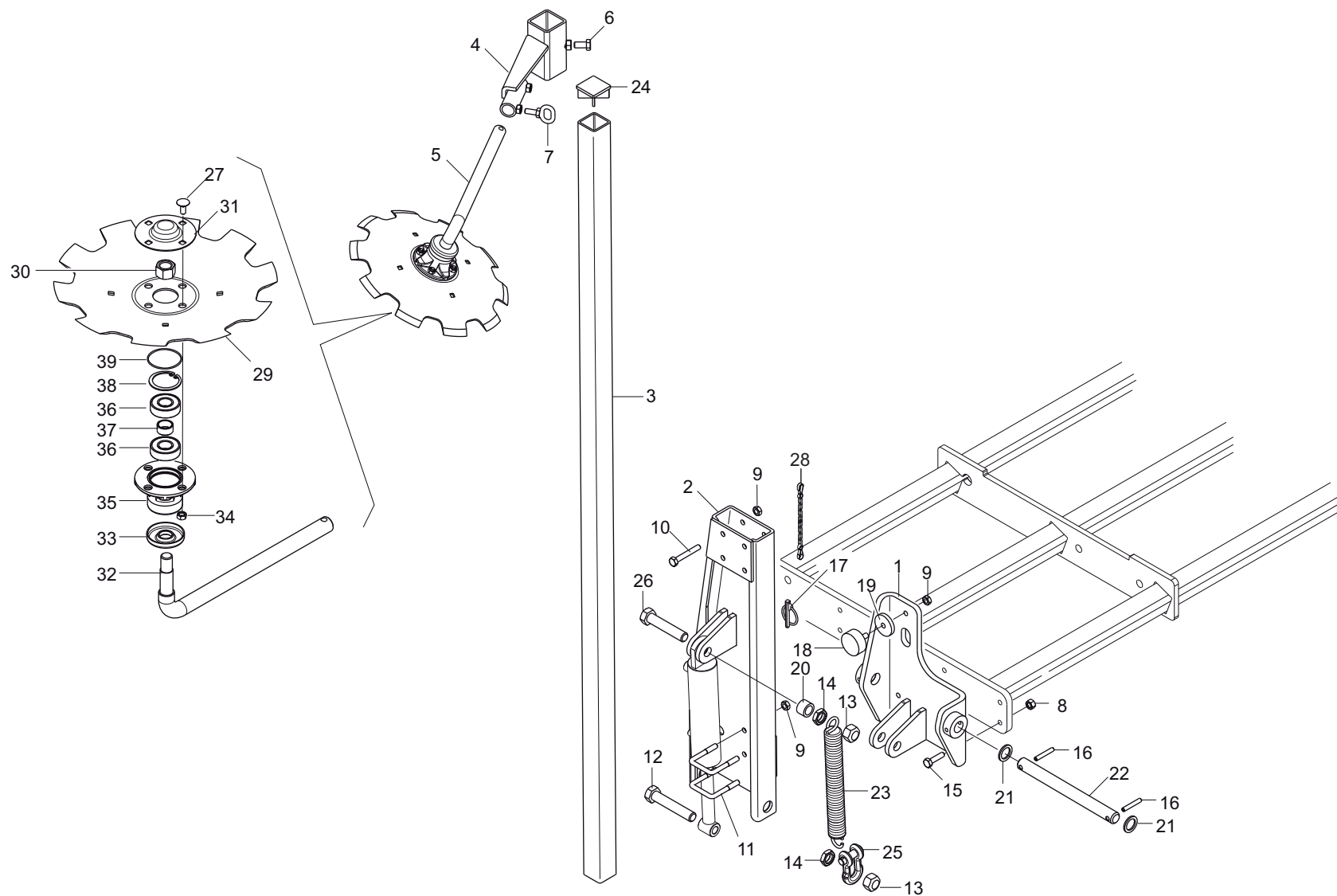

SEGNAFILE (mod. 400/450)
TAV. 030

Pos.	Cod.	Descrizione	Description	Description	Benennung	Descripcion
1	G17913950	SUPPORTO SEGNAFILE	ROW MARKER SUPPORT	SUPPORT TRACEUR	HALTERUNG REIHENANREISSER	SOPORTE MARCADOR DE FILAS
2	G17913960	SUPPORTO BRACCIO PER DISCO	ARM SUPPORT	RACLEUR BAGUE	HALTERUNG ARM	SOPORTE BRAZO
3	G16710780	TUBO Q. 50X 4X1930				
4	G17910380	SUPPORTO DISCO SEGNAFILE				
5	G17916840	DISCO SEGNAFILE COMPL	COMPL. ROW MARKER DISC	DISQUE TRACEUR COMPL	SPURREISSERSCHEIBE KOMPL.	DISCO MARCADOR DE SURCOS COMPL
6	F01020508	VITE M12X1,75X25 U5739 8.8 ZN	SCREW M12X1,75X25 5739 8.8 ZN	VIS M12X1,75X25 5739 8.8 ZN	SCHRA. M12X1,75X25 5739 8.8 ZN	TORN. M12X1,75X25 5739 8.8 ZN
7	G16713880	FERMO DISCO	DISK STOP	ARRET DISQUE	FESTSTELL SCHEIBE	BLOQUEO DISCO
8	F01230059	DADO M12X1,75 D982 8 ZN	NUT M12X1,75 D982 8 ZN	ECROU M12X1,75 D982 8 ZN	MUTTER M12X1,75 D982 8 ZN	TUERCA M12X1,75 D982 8 ZN
9	F01220033	DADO M10X 1,5 D980 8 ZN	NUT M10X 1,5 D980 8 ZN	ECROU M10X 1,5 D980 8 ZN	MUTTER M10X 1,5 D980 8 ZN	TUERCA M10X 1,5 D980 8 ZN
10	F01020122	VITE 10X 1,5X 70 U5737 8.8 ZN	BOLT 10X 1,5X 70 U5737 8.8 ZB	VIS 10X 1,5X 70 U5737 8.8 ZB	SCHR.10X 1,5X 70 U5737 8.8 ZB	TORN.10X 1,5X 70 U5737 8.8 ZB
11	F20110715	CAV.Q.M10X 1,5X 30 61X 80 ZN				
12	F01020313	VITE M20X2,5X110 U5737 8.8 ZN	SCREW M20X2,5X110 U5737 8.8 ZN	VIS M20X2,5X110 U5737 8.8 ZN	SCHRA.M20X2,5X110 U5737 8.8 ZN	TORN. M20X2,5X110 U5737 8.8 ZN
13	F01230131	DADO M20X 2,5 D982 6 ZN	NUT M20X 2,5 D982 6 ZN	ECROU M20X 2,5 D982 6 ZN	MUTTER M20X 2,5 D982 6 ZN	TUERCA M20X 2,5 D982 6 ZN
14	F01200468	DADO M20X 2,5 U5589 6.8 ZN	NUT 20 5589 6.8 GALVANISED *	ECROU 20 5589 5.8 ZN *	MUTTER 20 5589 6.8 ZN *	TUERCA 20 5589 6.8 ZN
15	F01020152	VITE M12X1,75X 40 U5737 8.8 ZN	SCREW M12X1,75X40 U5737 8.8 ZN	VIS M12X1,75X 40 U5737 8.8 ZN	SCHR.M12X1,75X 40 U5737 8.8 ZN	TORN.M12X1,75X 40 U5737 8.8 ZN
16	F02100144	SPINA E.P. 8X 50 U6873 C70 BR	ELASTIC PIN D8 L50 D1481 C70BR	FICHE EL. D8 L50 D1481 C70 BR	SPANNSTIFT D8 L50 D1481 C70BR	CLAVIJA D8 L50 D1481 C70 BR
17	F02200507	SPINA SCATTO D. 9 B/83 ZN	SNAP PIN D9 B/83 ZN	FICHE A DETENTE D9 B/83 ZN	EINRASTSTIFT D9 B/83 ZN	CLAVIJA DE MUELLE D9 B/83 ZN
18	F05150460	PARACOLPI CIL.D50X21 M10X26,5	RUBBER BUFFER- CYLINDR.D50X21	PARE-CHOC CYL. D50X21	PUFFER ZYL.50X21	PARAGOLPES CIL.D50X21
19	G20970006	RONDELLA 48X8X11	WASHER 48X8X11	RONDELLE 48X8X11	UNTERLEGSCHLEIBE 48X8X11	ARANDELA 48X8X11
20	G18802330	BOCCOLA 20,5X30X20 ZN	BUSHING 20,5X30X20 ZN	BOITE 20,5X30X20 ZN	BUCHSE 20,5X30X20 ZN	CASQUILLO 20,5X30X20 ZN
21	G18701590	RONDELLA 25X35X2,5 ZN	WASHER 25 X35 X2,5 ZN	RONDELLE 25 X35 X2,5 ZN	SCHEIBE 25 X35 X2,5 ZN	ARANDELA 25 X35 X2,5 ZN
22	G17110890	SPINA D.25X243				
23	G65337004	MOLLA TRAZ.SOLLEV. FU	TRACTION SPRING LIFT. FU	RESSORT TRACT. LEVAGE FU	ZUGFEDER HEBUNG FU	MUELLE TRAC. LEVDEL. FU
24	F20120349	PUNTALE Q.50 ALETT.POLIT.NERO				
25	F02250664	GRILLO D16 U1947C ZN	CLEVIS 5/8 GALVANISED-	MANILLE 5/8 ZN	U KETTENANSCHLUSS DA 5/8 ZN	GRILLETE DA 5/8 ZN
26	F01020312	VITE M20X2,5X100 U5737 8.8 ZN	SCREW M20X2,5X100 U5737 8.8 ZN	VIS M20X2,5X100 U5737 8.8 ZN	SCHRA.M20X2,5X100 U5737 8.8 ZN	TORN. M20X2,5X100 U5737 8.8 ZN
27	F01060040	BUL.M 8X1,25X 20 U5732 4.6 ZG	BOLT 8 X20 5732 4.6 GALVANIZED	VIS 8 X20 5732 4.6 ZN	SCHRAUBE 8 X20 5732 4.6 ZN	TORNILLO 8 X20 5732 4.6 ZN
28	G13812311	CATENELLA CON MOSCHETTONE	CHAIN WITH SPRING CATCH	CHAINETTE AVEC MOUSQUETON	KETTE MIT KARABINERHAKEN	CADENA CON GANCHO
29	G16072590	DISCO SEGNAFILE D.350	ROW MARKER DISK D.350	DISQUE TRACEUR D350	SPURREISSERSCHEIBE D. 350	DISCO MARCADOR DE FILAS O 350
30	F01230098	DADO M18X 2,5 D982 8 ZN	NUT M18X 2,5 D982 8 ZN	ECROU M18X 2,5 D982 8 ZN	MUTTER M18X 2,5 D982 8 ZN	TUERCA M18X 2,5 D982 8 ZN
31	G16610190	CHIUSURA CUSCINETTO ZN	GALVAN. BEARING CLOSURE	FERMETURE ROULEMENT ZN	LAGERVERSCHLUSS ZN	CIERRE COJINETE ZN
32	G17916220	PERNO REGGIDISCO SEGNAFILE	ROWMAKER DISC-HOLDER PIN	PIVOT PORTE-DISQUE TRACEUR	SCHEIBENTRAGBOLZEN	PERNO SOPORTE DISCO MARCAFILA
33	G16610430	FONDELLO ZN.				
34	F01200244	DADO M 8X1,25 U5588 6.8 ZN	NUT M8	ECROU M8	MUTTER M8	DADO M8
35	G16610160	SUPP.CUSCINETTI DISCO SEGN.ZN.	GALVAN. ROWMAKER DISK BEARING	SUPPORT ROULEMENTS DISQUE TRAC	SCHEIBENLAGERHALTERUNG	SOPORTE COJINETE DE DISCO MARC
36	F04010156	CUSC.d20 D47 B14 6204 2RSH				
37	G18801270	BOCCOLA 21 X25 X12 ZN	BUSHING 21 X 25 X 12 ZN	BOITE 21 X25 X12 ZN	BsCHSE 21 X25 X12 ZN	CASQUILLO 21 X25 X12 ZN
38	F02050370	ANELLO E. DI 47X1,75 U7437 C70	SEEGER RING 47X 1,75 U7437 C70	SEEGER E. 47X 1,75 U7437 C70	SEEGERING E. 47X1,75 U7437 C70	ANILLO E. 47X 1,75 U7437 C70
39	F03010576	ANELLO OR 50,52X1,78 NBR	GASKET OR 033 DOWTY	BAGUE OR 033 DOWTY	RING OR 033 DOWTY	ANILLO OR 033 DOWTY

TAV. 040

mod. 400/450

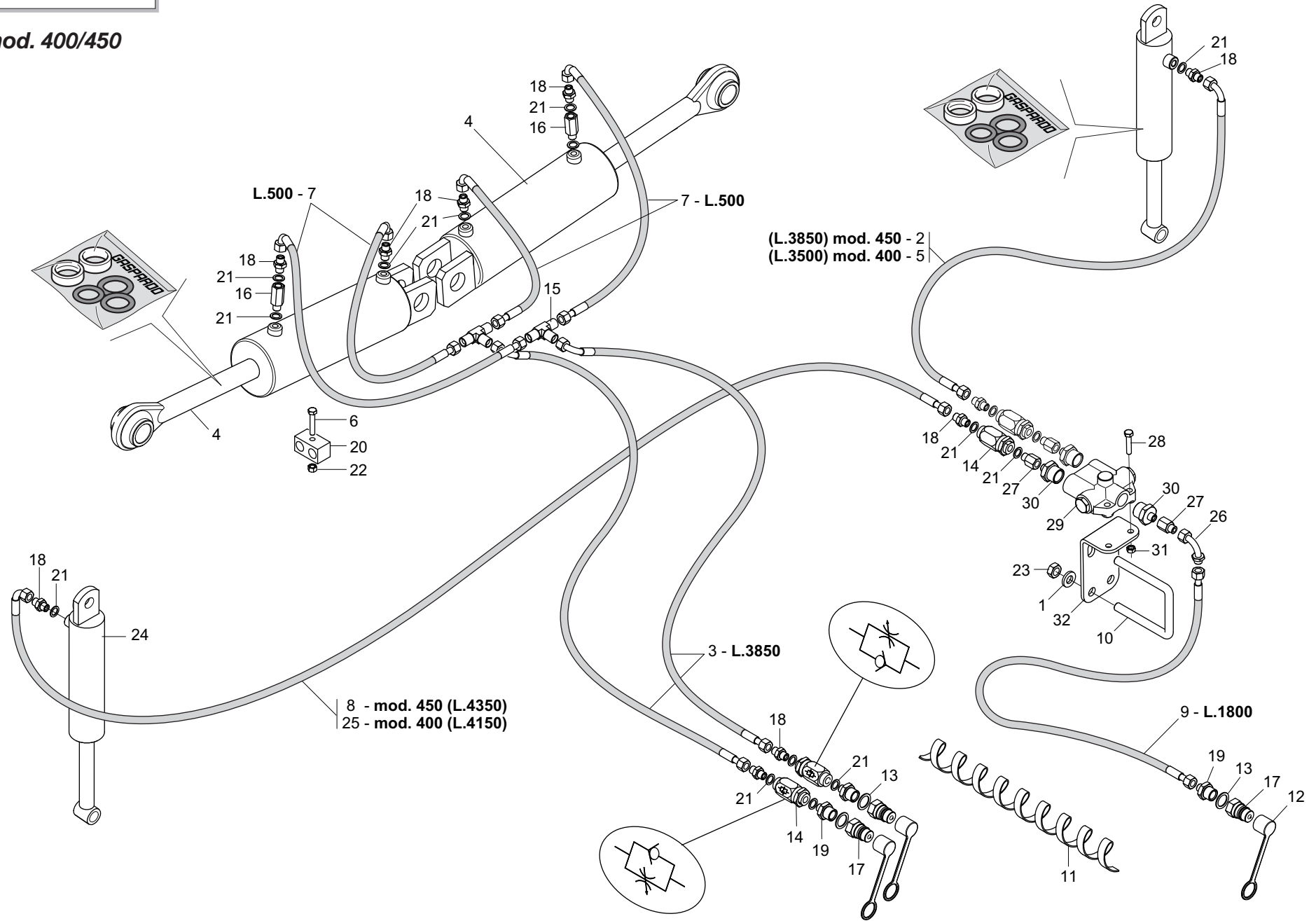

IMPIANTO OLEODINAMICO SEGNAFILE (mod. 400/450)
TAV. 040

Pos.	Cod.	Descrizione	Description	Description	Benennung	Description
1	G20970011	RONDELLA 28X4X14,5	WASHER 28X4X14.5	RONDELLE 28X4X14,5	UNTERLEGSCHLEIBE 28X4X14,5	ARANDELA 28X4X14,5
2	G15413060	TUBO 1/4R2 CF1/4- F1/4 3850	TUBE 1/4R2 CF1/4-F1/4 3850	TUYAU 1/4R2 CF1/4-F1/4 3850	SCHLAUCH 1/4R2 CF1/4-F1/4 3850	TUBO 1/4R2 CF1/4-F1/4 3850
3	G17915100	TUBO 1/4 F-F L.2800	PIPE 1/4 F-F L.2800	TUBE 11/4 F-F L.2800	ROHR 1/4 F-F L.2800	TUBO 1/4 F-F L.2800
4	G17913720	CILINDRO TELAIO POSTERIORE				
5	G15210561	TUBO 1/4R2 CF1/4- F1/4 3500				
6	F01020072	VITE M 8X1,25X50 U5737 8.8 ZN	SCREW M8X1,25X50 U5737 8.8 ZN	VIS M8X1,25X50 U5737 8.8 ZN	SCHR. M8X1,25X50 U5737 8.8 ZN	TORN. M8X1,25X50 U5737 8.8 ZN
7	G16011670	TUBO 1/4' R2 C-F 1/4' L.500	PIPE 1/4'R2 C-F 1/4'L.500	TUBE 1/4'R2 C-F 1/4'L. 500	ROHR 1/4'R2 C-F 1/4'L 500	TUBO 1/4'R2 C-F 1/4'L.500
8	G17915340	TUBO 1/4R2 F-CF L.4350				
9	G13611771	TUBO 1/4R2 F1/4-F1/4 1800	PIPE 1/4R2 F1/4-F1/4 1800	TUBE 1/4R2 F1/4-F1/4 1800	ROHR 1/4R2 F1/4-F1/4 1800	TUBO 1/4R2 F1/4-F1/4 1800
10	F20110770	CAV.Q.M14X 2X 50 96X119 ZN	FLANGE U M14X2X50 96X119 ZN	BRIDE U M14X2X50 96X119 ZN	ANSCHLANG U M14X2X50 96X119 ZN	EL.DE EMPALME M14X2X50 96X119
11	F05150485	SPIRALE PROTETTIVAD.44-50	SPIRAL GUARD	SPIRALE PROTECTION	SPIRAL SCHUTZ	ESPIRAL PROTECIÉN
12	F05150325	CAPPUC.F X INN.M RAP.1/2 ROSSO	COVER CONNECT F 1/2 RED	COUVERCLE CONNEXION F 1/2 ROSE	DECKEL W 1/2 SCHNELLKUPP. ROT	PAC PROTECCION F 1/2 ROJO
13	F03151237	ROS. 21 X27X1,5 RAME -1/2"	COPPER WASHER 21X27X1,5 1/2	RONDELLE CUIVRE 1/2 21X27X1,5	SCHEIBE KUPFER 1/2 21X27X1,5	ARANDELA COBRE 1/2 21X27X1,5
14	F03151226	REGOL.DI FLUSSO VRF 1/4' GAS	1/4' GAS VALVE VRF	SOUPAPE REG DEBIT VRF 1/4" GAZ	VENITL VRF 1/4' GAS	VæLVULA VRF 1/4' GAS
15	F03151219	RACCORDO -T- MASCHIO 1/4 ZN	MALE T-UNION 1/4 ZINC.	RACCORD -T- MALE 1/4 ZING.	ANSCHLUSSTsCK -T- GEWINDE 1/4	UNIN -T- MACHO 1/4 CINC. R
16	F03151037	COLONNETTA 1/4 M-F V.PARACAD.				
17	F03150935	INNESTO RAP.MASCH.1/2 A VALV.	QUICK CONNECT MALE CONE 1/2	CONNEXION RAPIDE MALE CONE 1/2	SCHNELLKUPP.GEWINDE KONISC 1/2	ACOPLAMIENT.RAP.MACHO CONO 1/2
18	F03150266	NIPPLO MM CIL-CIL 1/4-1/4 ZN	NIPPLE GALV.CYL.MALE 1/4 ZN	NIPPLE MALE CYL. 1/4 ZN	NIPPELZYL.1/4 ZN	NIPLE MACHO CIL.1/4 ZN
19	F03150211	NIPPLO MM CIL-CIL 1/2-1/4 ZN	NIPLE 1/4-1/2	NIPLE 1/4-1/2	NIPLE 1/4-1/2	NIPLE 1/4-1/2
20	F02350014	BLOCCHETTO FERMA 2 TUBI D.18	FIXING BLOCK 2 TUBE D18	BLOQUE DE FIXATION 2 TUBE D18	BEFESTIGUNGS-BLOCK 2 ROHR D18	FIJACION DE BLOQUE 2 TUB. D18
21	F01500012	RONDELLA IN RAME 1/4"	WASHER	RONDELLE	SCHEIBE	ARANDELA
22	F01230034	DADO M 8X1,25 D982 8	SELF LOCK.NUT M8X1,25 D982 8ZN	ECROU AUTOBL.M8X1,25 D982 8 ZN	SELBST.MUTT.M8X1,25 D982 8 ZN	TUERCA AUTO. M8X1,25 D982 8 ZN
23	F01220255	DADO M14X 2 D980 8 ZN	NUT- TRISTOP M14X2 D980 8 ZN	ECROU TRISTOP M14X2 D980 8 ZN	MUTTER TRISTOP M14X2 D980 8 ZN	TUERCA TRISTOP M14X2 D980 8 ZN
24	G16712660	CILINDRO SE 25X50-135	CYLINDER SE 25X50-135	CYLINDRE SE 25X50-135	ZYLINDER SE 25X50-135	CILINDRO SE 25X50-135
25	G17915150	TUBO 1/4R2 F1/4-CF1/4 4150	TUBE 1/4R2 F1/4-CF1/4 4150	TUBE 1/4R2 F1/4-CF1/4 4150	ROHR 1/4R2 F1/4-CF1/4 4150	TUBO 1/4R2 F1/4-CF1/4 4150
26	F03150859	CURVA 90°F.GIREV.1/4 - M.1/4	ELBOW 90[F. SWIVEL 1/4 -M.1/4	COUDE 90[F.TOURN.1/4 - M.1/4	KNIESTsCK 90[F.DREHB.1/4 - M.	CURVA 90 F.GIRAT.1/4 - M.1/4C
27	F03151194	PROLUNGA CORTA 036 1/4	SHORT EXTENSION 036 1/4	RALLONGE COURTE 036 1/4	KURZE VERLZNGERUNG 036 1/4	PROLONG. CORTA 036 1/4
28	F01020068	VITE M 8X1,25X40 U5737 8.8 ZN	SCREW M8X1,25X40 U5737 8.8 ZN	VIS M 8X1,25X40 U5737 8.8 ZN	SCHRA. M8X1,25X40 U5737 8.8 ZN	TORNIL.M8X1,25X40 U5737 8.8 ZN
29	F03150577	VALVOLA SEGNAF.CROSS SQV	ROW MARKER VALVE ATI C128513			
30	F03150122	NIPPLO MM 3/4 JIC OR 1/4 OR ZG	NIPPLE- 3/4 JIC OR - 1/4	NIPPLE 3/4 JIC OR - 1/4	NIPPEL 3/4 JIC OR - 1/4	NIPLE 3/4 JIC OR - 1/4
31	F01200244	DADO M 8X1,25 U5588 6.8 ZN	NUT M8	ECROU M8	MUTTER M8	DADO M8
32	G15412351	SUPPORTO VALVOLA				

TAV. 050

mod. 500/600

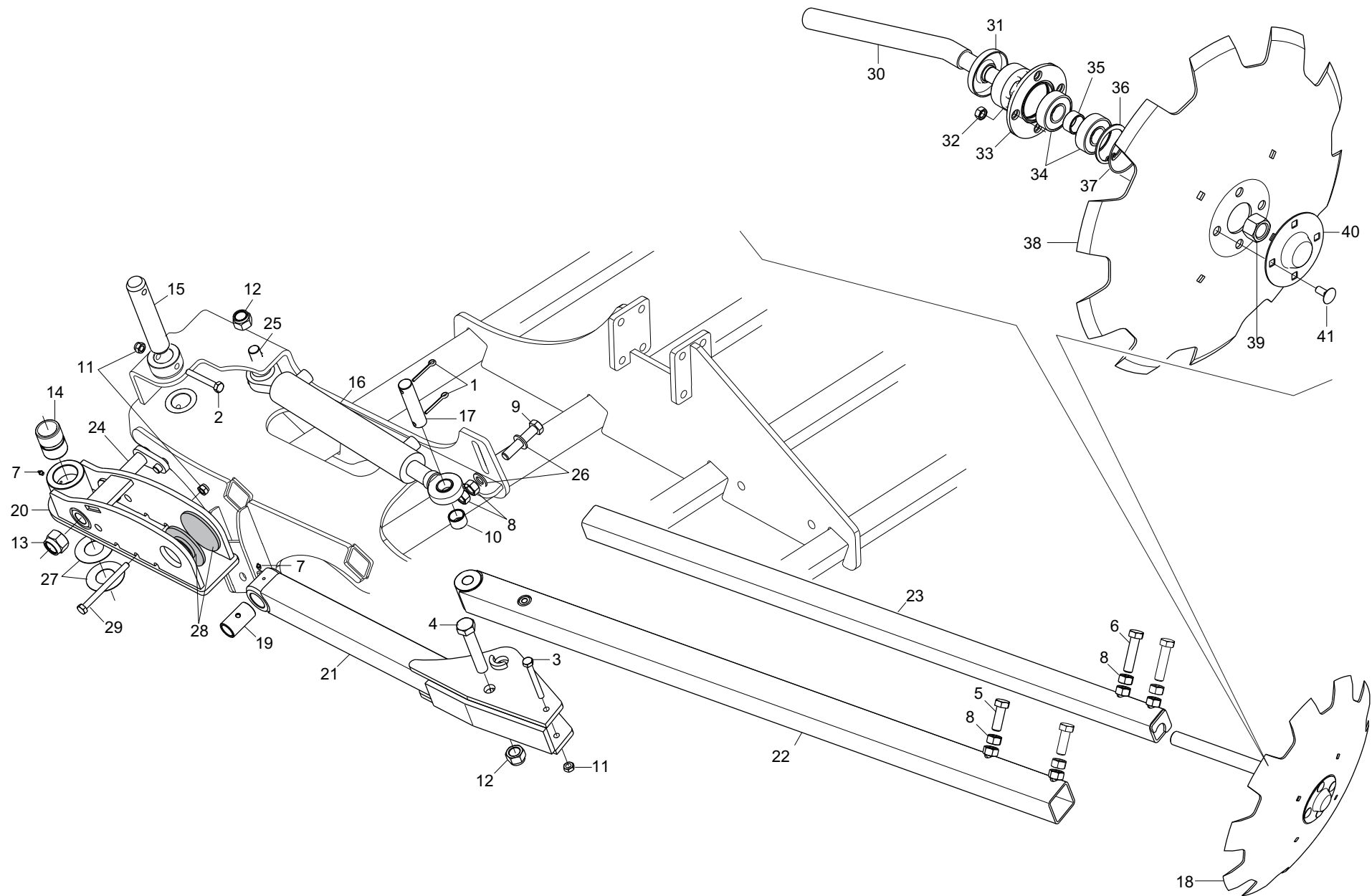

SEGNAFILE (mod. 500/600)

TAV. 050

Pos.	Cod.	Descrizione	Description	Description	Benennung	Descripcion
1	F02200229	COPIGLIA 5X 45 U1336 ZN	SPLIT PIN 5 X45 1336 GALVAN.	GOUPILLE 5 X45 1336 ZN	SPLINT 5 X45 1336 ZN	PASADOR 5 X45 1336 ZN
2	F01020126	VITE M10X1,5X 75 U5737 10.9 ZD	BOLT 10X75 5737 10.9 GALVANIZ.	VIS 10X75 5737 10.9 ZN	SCHRAUBE 10X75 5737 10.9 ZN	TORNILLO 10X75 5737 10.9 ZN
3	F01020133	VITE M10X1,5X100 U5737 8.8 ZN	BOLT 10X100 5737 8.G GALVANIZ.	VIS 10X100 5737 8.G ZN	SCHRAUBE 10X100 5737 8.G ZN	TORNILLO 10X100 5737 8.G ZN
4	F01020313	VITE M20X2,5X110 U5737 8.8 ZN	SCREW M20X2,5X110 U5737 8.8 ZN	VIS M20X2,5X110 U5737 8.8 ZN	SCHRA.M20X2,5X110 U5737 8.8 ZN	TORN.M20X2,5X110 U5737 8.8 ZN
5	F01020568	VITE M16X 2X45 U5739 8.8 ZN	BOLT M 16X 2X45 U5739 8.8 ZG	VIS M 16X 2X45 U5739 8.8 ZG	SCHRAUBE M 16X 2X45 U5739 8.8	TORNILLO M16X 2X45 U5739 8.8
6	F01020576	VITE M16X 2X65 U5739 8.8 ZN	BOLTM16X2X65	VIS M16X2X65	SCHRAUBE M16X2X65	TORNILLO M16X2X65
7	F01100011	ING.M 6X1 7663-A 9SMNPB28 ZN	GREASE NIPPLE M6X1 7663-A ZN	GRAISSEUR A BILLES M6X1 7663-A	SCHMIERBUECHE M6X1 7663-A ZN	ENGRAS. DE ESFERAS M6X1 7663-A
8	F01200324	DADO M16X 2 U5588 8.8 ZN	NUT 16 UNI 5588 8.8 GALVANIZED	ECROU 16 UNI 5588 8.8 ZN	MUTTER 16 UNI 5588 8.8 ZN	TUERCA 16 UNI 5588 8.8 ZN
9	F01020579	VITE M16X 2X80 U5739 8.8 ZN	SCREW 16X80 5739 8.G GALVANIZ.	VIS 16X80 5739 8.G ZN	SCHRAUBE 16X80 5739 8.G ZN	TORNILLO 16X80 5739 8.G ZN
10	G18803290	BOCCOLA 25,4X30X20 ZN				
11	F01230048	DADO M10X 1,5 D982 8 ZN	NUT AUTOBLOC. M10 ZB	ECROU AUTOBLOC. M10 ZB	SCHEIBE AUTOBLOC. M10 ZB	TUERCA AUTOBLOC M10 ZB
12	F01230131	DADO M20X 2,5 D982 6 ZN	NUT M20X 2,5 D982 6 ZN	ECROU M20X 2,5 D982 6 ZN	MUTTER M20X 2,5 D982 6 ZN	TUERCA M20X 2,5 D982 6 ZN
13	F01230143	DADO M24X 2 D982 8 ZN	NORMAL SELF-LOCK.NUT 24X2 GAL	ECROU AUTOB. NOR. 24X2 ZN	MUTTER AUTOB.NOR.24X2 ZN	TUERCA AUTOB. NOR.24X2 ZN
14	G15320041	BOCCOLA BRACCIO DIRECTA	DIRECTA ARM BUSHING	BOITE BRAS DIRECTA	BsCHSE ARM DIRECTA	CASQUILLO BRAZO DIRECTO
15	G16113350	SPINA	PIN ZN	GOUPILLE ZN	BOLZENSTIFT ZN	PASADOR ZN
16	G16117980	CILINDRO DE 30X50 -240 >				
17	G15310160	SPINA PROLUNGA 1-2° PUNTO	EXTENSION 1.-2. POINT PIN	BROCHE RALLONGE 1-2. POINT	VERLZNGERUNGSSTIFT 1-2. PUNKT	CLAVIJA PROLONGACIN 1-2. PUNTS
18	G17712730	MONT.DISCO SEGNAFILE				
19	G17914820	BOCCOLA 25X33X60 ZN	BUSHING 25X33X60 ZN	BOITE 25X33X60 ZN	BUCHSE 25X33X60 ZN	CASQUILLO 25X33X60 ZN
20	G17918560	ASS.SUPP.E GUIDA BRACCIO SEGN.				
21	G17918620	ASS.BRACCIO DI SUPP.				
22	G17918690	ASS.TUBO TELESC.E VITE DI SIC.				
23	G17918710	ASS.TUBO TELESCOPICO				
24	G17918740	ASS.PERNO PER CERNIERA >				
25	G17918760	ASS.PERNO FISS.CILINDRO SEGN.>				
26	F01410100	ROS.M16 17X 30X 3 U6592 ZN	PLANE WASHER D16 UNI 6592 ZN	RONDELLE D16 UNI 6592 ZN	SCHEIBE D.16 UNI 6592 ZN	ARANDELA D16 UNI 6592 ZN
27	G18701730	RONDELLA 35,5 X71 X1	WASHER 35.5 X 71 X 1	RONDELLE 35-5 X71 X1	UNTERLEGSSCHEIBE 35-5 X71 X1	ARANDELA 35-5 X71 X1
28	G19003570	PIASTRA SCORRIMENTO SP.11	SLIDING PLATE SP.11	PLAQUE GLISSEMENT SP.11	GLEITPLATTE SP.11	PLACA DE DESPLAZAMIENTO SP.11
29	F01020137	VITE M10X1,5X120 U5737 8.8 ZN	GALVANIZ. SCREW 10X120 5737 ZN	VIS 10X120 5737 8.G ZN	SCHRAUBE 10X120 5737 8.G ZN	TORNILLO 10X120 8.G ZN
30	G17712720	PERNO REGGI DISCO SEGNAFILE				
31	G16610430	FONDELLO ZN.				
32	F01200244	DADO M 8X1,25 U5588 6.8 ZN	NUT M8	ECROU M8	MUTTER M8	DADO M8
33	G16610160	SUPP.CUSCINETTI DISCO SEGN.ZN.	GALVAN. ROWMAKER DISK BEARING	SUPPORT ROULEMENTS DISQUE TRAC	SCHEIBENLAGERHALTERUNG	SOPORTE COJINETE DE DISCO MARC
34	F04010156	CUSC.d20 D47 B14 6204 2RSB				
35	G18801270	BOCCOLA 21 X25 X12 ZN	BUSHING 21 X 25 X 12 ZN	BOITE 21 X25 X12 ZN	BsCHSE 21 X25 X12 ZN	CASQUILLO 21 X25 X12 ZN
36	F02050370	ANELLO E. DI 47X1,75 U7437 C70	SEEGER RING 47X 1,75 U7437 C70	SEEGER E. 47X 1,75 U7437 C70	SEEGERING E. 47X1,75 U7437 C70	ANILLO E. 47X 1,75 U7437 C70
37	F03010576	ANELLO OR 50,52X1,78 NBR	GASKET OR 033 DOWTY	BAGUE OR 033 DOWTY	RING OR 033 DOWTY	ANILLO OR 033 DOWTY
38	G17712830	DISCO SEGNAFILE D.450				
39	F01230098	DADO M18X 2,5 D982 8 ZN	NUT M18X 2,5 D982 8 ZN	ECROU M18X 2,5 D982 8 ZN	MUTTER M18X 2,5 D982 8 ZN	TUERCA M18X 2,5 D982 8 ZN
40	G16610190	CHIUSURA CUSCINETTO ZN	GALVAN. BEARING CLOSURE	FERMETURE ROULEMENT ZN	LAGERVERSCHLUSS ZN	CIERRE COJINETE ZN
41	F01060040	BUL.M 8X1,25X 20 U5732 4.6 ZG	BOLT 8 X20 5732 4.6 GALVANIZED	VIS 8 X20 5732 4.6 ZN	SCHRAUBE 8 X20 5732 4.6 ZN	TORNILLO 8 X20 5732 4.6 ZN

TAV. 060

mod. 500/600

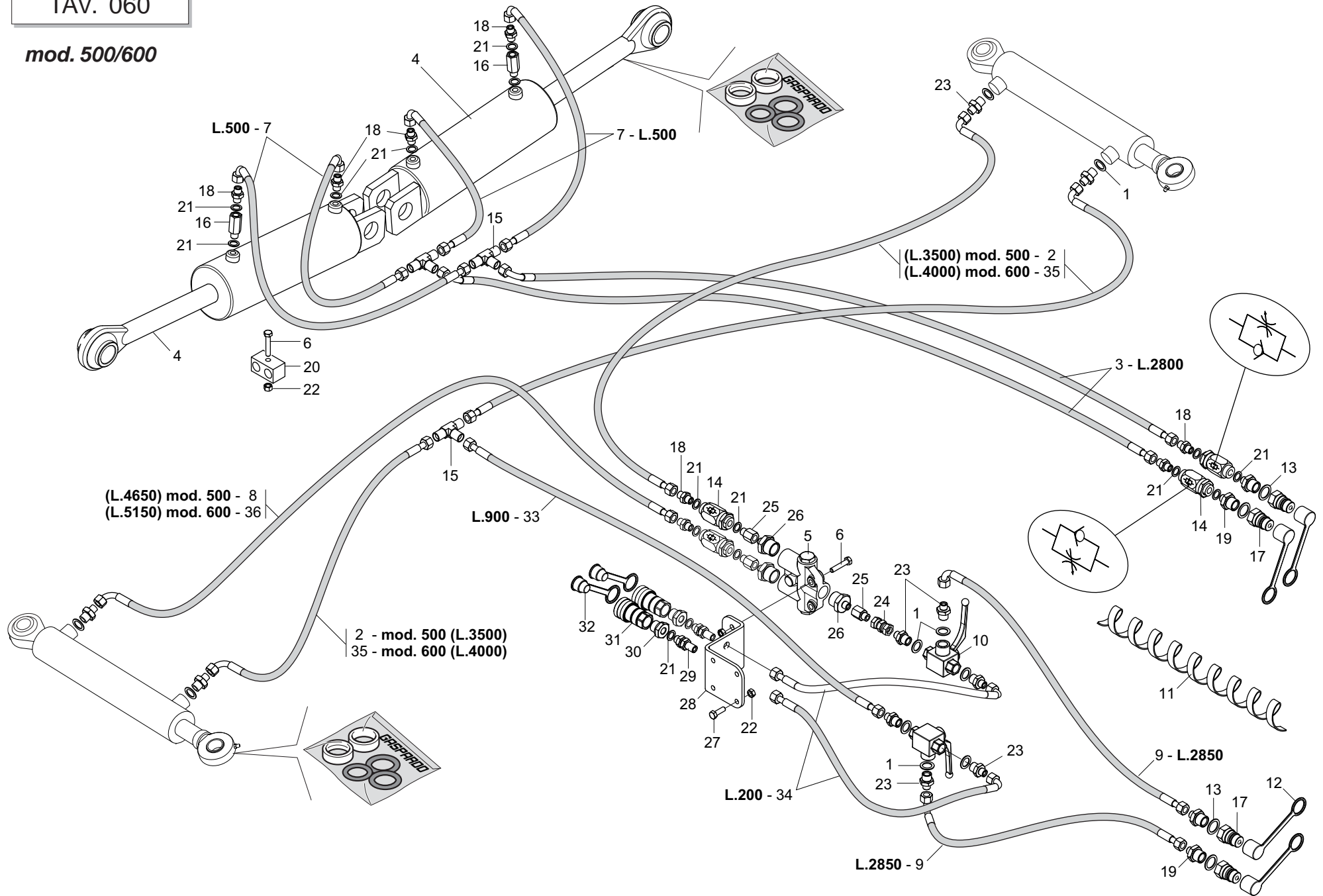

IMPIANTO OLEODINAMICO SEGNAFILE (mod. 500/600)
TAV. 060

Pos.	Cod.	Descrizione	Description	Description	Benennung	Description
1	F03151240	ROS. 17 X23X1,5 RAME -3/8"	COPPER WASHER 17X23X1,5 3/8"	RONDELLE CUIVRE 17X23X1,5 3/8"	SCHEIBE KUPFER 17X23X1,5 3/8"	ARADNDELA COBRE 17X23X1,5 3/8"
2	G15210561	TUBO 1/4R2 CF1/4- F1/4 3500				
3	G17915100	TUBO 1/4 F-F L.2800	PIPE 1/4 F-F L.2800	TUBE 11/4 F-F L.2800	ROHR 1/4 F-F L.2800	TUBO 1/4 F-F L.2800
4	G17913720	CILINDRO TELAIO POSTERIORE				
5	F03150577	VALVOLA SEGNAF.CROSS SQV	ROW MARKER VALVE ATI C128513			
6	F01020072	VITE M 8X1,25X50 U5737 8.8 ZN	SCREW M8X1,25X50 U5737 8.8 ZN	VIS M8X1,25X50 U5737 8.8 ZN	SCHR. M8X1,25X50 U5737 8.8 ZN	TORN. M8X1,25X50 U5737 8.8 ZN
7	G16011670	TUBO 1/4' R2 C-F 1/4' L.500	PIPE 1/4'R2 C-F 1/4'L.500	TUBE 1/4'R2 C-F 1/4'L. 500	ROHR 1/4'R2 C-F 1/4'L 500	TUBO 1/4'R2 C-F 1/4'L.500
8	G15413080	TUBO 1/4 C-F L.4650	TUBE 1/4 C-F L.4650	TUBE 1/4 C-F L.4650	ROHR 1/4 C-F L.4650	TUBO 1/4 C-F L.4650
9	G15210554	TUBO 1/4R2 F1/4-CF1/4 2850				
10	F03151295	RUBINETTO A 3 VIE 3/8				
11	F05150484	SPIRALE PROTETTIVA D.27-32				
12	F05150325	CAPPUC.F X INN.M RAP.1/2 ROSSO	COVER CONNECT F 1/2 RED	COUVERCLE CONNEXION F 1/2 ROSE	DECKEL W 1/2 SCHNELLKUPP. ROT	PAC PROTECCION F 1/2 ROJO
13	F03151237	ROS. 21 X27X1,5 RAME -1/2"	COPPER WASHER 21X27X1,5 1/2	RONDELLE CUIVRE 1/2 21X27X1,5	SCHEIBE KUPFER 1/2 21X27X1,5	ARANDELA COBRE 1/2 21X27X1,5
14	F03151226	REGOL.DI FLUSSO VRF 1/4' GAS	1/4' GAS VALVE VRF	SOUPAPE REG DEBIT VRF 1/4" GAZ	VENITL VRF 1/4' GAS	VæLVULA VRF 1/4' GAS
15	F03151219	RACCORDO -T- MASCHIO 1/4 ZN	MALE T-UNION 1/4 ZINC.	RACCORD -T- MALE 1/4 ZING.	ANSCHLUSSTsCK -T- GEWINDE 1/4	UNIN -T- MACHO 1/4 CINC. R
16	F03151037	COLONNETTA 1/4 M-F V.PARACAD.				
17	F03150935	INNESTO RAP.MASCH.1/2 A VALV.	QUICK CONNECT MALE CONE 1/2	CONNEXION RAPIDE MALE CONE 1/2	SCHNELLKUPP.GEWINDE KONISC 1/2	ACOPLAMIENT.RAP.MACHO CONO 1/2
18	F03150266	NIPPLO MM CIL-CIL 1/4-1/4 ZN	NIPPLE GALV.CYL.MALE 1/4 ZN	NIPPLE MALE CYL. 1/4 ZN	NIPPELZYL.1/4 ZN	NIPLE MACHO CIL.1/4 ZN
19	F03150211	NIPPLO MM CIL-CIL 1/2-1/4 ZN	NIPLE 1/4-1/2	NIPLE 1/4-1/2	NIPLE 1/4-1/2	NIPLE 1/4-1/2
20	F02350014	BLOCCETTO FERMA 2 TUBI D.18	FIXING BLOCK 2 TUBE D18	BLOQUE DE FIXATION 2 TUBE D18	BEFESTIGUNGS-BLOCK 2 ROHR D18	FIJACION DE BLOQUE 2 TUB. D18
21	F01500012	RONDELLA IN RAME 1/4"	WASHER	RONDELLE	SCHEIBE	ARANDELA
22	F01230034	DADO M 8X1,25 D982 8	SELF LOCK.NUT M8X1,25 D982 8ZN	ECROU AUTOBL.M8X1,25 D982 8 ZN	SELBST.MUTT.M8X1,25 D982 8 ZN	TUERCA AUTO. M8X1,25 D982 8 ZN
23	F03150310	NIPPLO MM CIL-CIL 3/8-1/4 ZN	NIPPLE GALV.CYL.MALE3/8-1/4 ZN	NIPPLE MALE CYL.3/8-1/4 ZN	NIPPELZYL.3/8-1/4 ZN	NIPLE MACHO CIL.3/8-1/4 ZN
24	F03150100	NIPPLO F-F GIREVOLE 1/4 ZG CIL	NIPPLE F-F SWIVEL 1/4 ZINC. CY	NIPPLE F-F TOURNANT CYL. 1/4 Z	NIPPELZYL. F-F DREHBAR 1/4 VER	NIPLE F-F GIRATORIO CIL. 1/4 C
25	F03151194	PROLUNGA CORTA 036 1/4	SHORT EXTENSION 036 1/4	RALLONGE COURTE 036 1/4	KURZE VERLZNGERUNG 036 1/4	PROLONG. CORTA 036 1/4
26	F03150122	NIPPLO MM 3/4 JIC OR 1/4 OR ZG	NIPPLE- 3/4 JIC OR - 1/4	NIPPLE 3/4 JIC OR - 1/4	NIPPEL 3/4 JIC OR - 1/4	NIPLE 3/4 JIC OR - 1/4
27	F01020440	VITE M 8X1,25X25 U5739 8.8 ZN	BOLT M8 X25 5739 8.8 ZN	VIS M8 X25 5739 8.8 ZN	SCHRAUBE M8 X25 5739 8.8 ZN	TORNILLO M8 X25 5739 8.8 ZN
28	G17919270	LAMA SUPPORTO VALVOLA				
29	F05010359	PASSAPARETE 1/4M-1/4M	FAIRLEAD 1/4M-1/4M	TUILE EN 1/4M-1/4M	VOR_BERGEHENDE 1/4M-1/4M	PASTECA 1/4M-1/4M
30	F03150398	NIPPLO MF CIL-CIL 1/2-1/4 ZN				
31	F03150948	INNESTO RAP.FEMM.1/2 A VALVOLA	QUICK-CONNECT 1/2 VALVE FEM.	ACCOUPL. RAPIDE FEM.1/2 VANNE	SCHNELLKUPPLUNG NUT 1/2	ACOPLA. RÁP.HEMB.1/2 VÁLVULA
32	F05150327	CAPPUCCIO INNESTO RAP.FEMM.1/2				
33	G17916200	TUBO 1/4R2 F1/4- F1/4 900	PIPE 1/4R2 F1/4- F1/4 900	TUBE 1/4R2 F1/4- F1/4 900	ROHR 1/4R2 F1/4- F1/4 900	TUBO 1/4R2 F1/4- F1/4 900
34	G14218690	TUBO 1/4R2 CF-F L. 200	PIPE 1/4R2 CF-F L. 200	TUBE 1/4R2 CF-F L. 200	ROHR 1/4R2 CF-F L. 200	TUBO 1/4R2 CF-F L. 200
35	G16012650	TUBO R2 1/4 C-F L.4000	PIPE 1/4 R2 C-F 1/4 L.4000	TUBE 1/4 R2 C-F 1/4 L. 4000	ROHR 1/4 R2 C-F 1/4 L 4000	TUBO 1/4 R2 C-F 1/4 L.4000
36	G17915350	TUBO 1/4R2 F-CF L.5150				

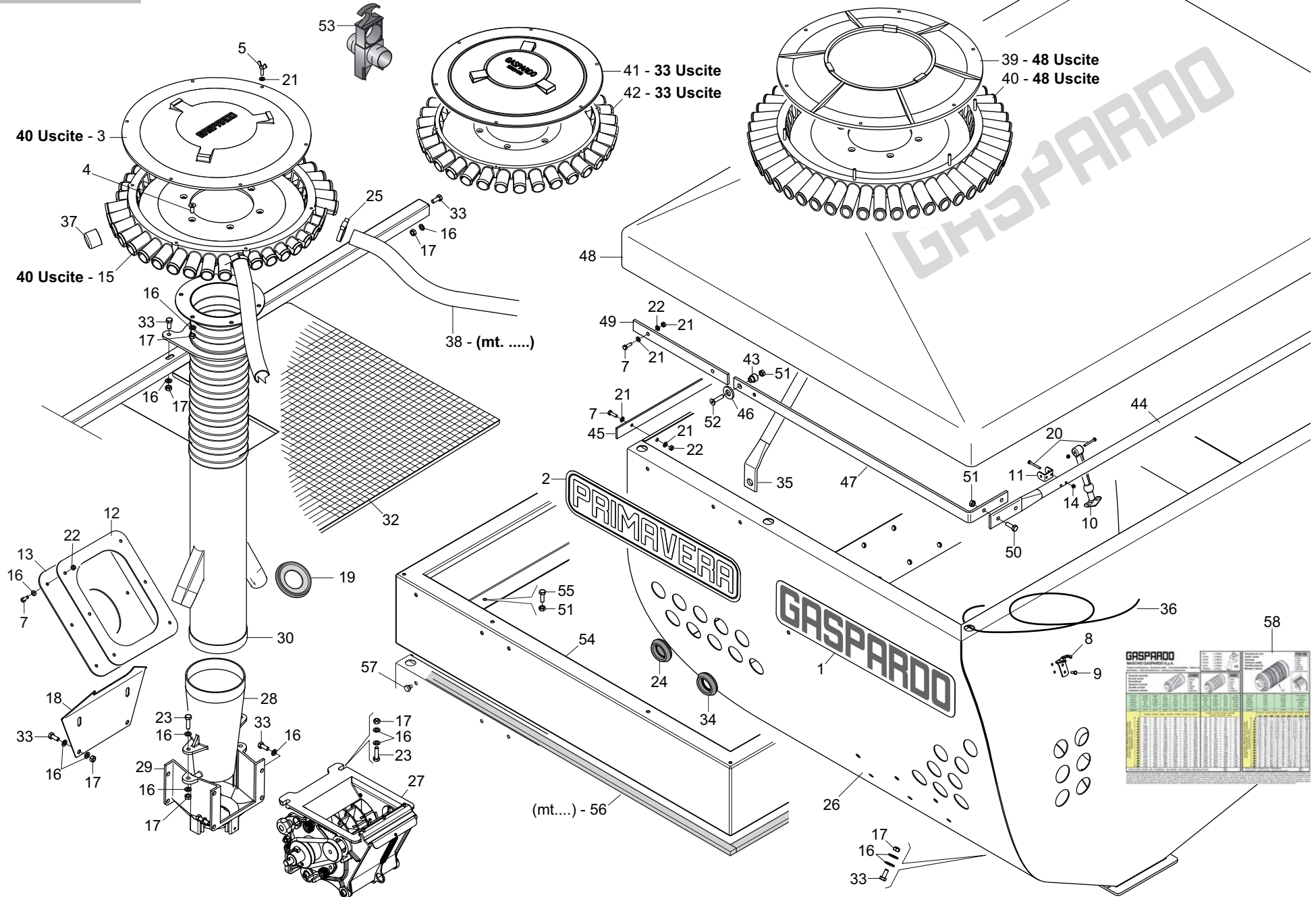

TRAMOGGIA

TAV. 070

Pos.	Cod.	Descrizione	Description	Description	Benennung	Descrpcion
1	G19706140	DECAL.GASPARDO H90				
2	G19707401	DECAL."PRIMAVERA"				
3	G17920200	COPERCHIO DISTRIBUTORE 40 U.	DISTRIBUTOR COVER 40 OUTPUTS	COUVERCLE DISTRIBUTEUR 40 SORT	DECKEL SZAPPARAT 40 AUSGZNG	TAPA DISTRIBUIDOR 40 SALIDAS
4	F01030056	VITE M 8X1,25X25 U5933 10.9 ZD	BOLT 8X25 5933 10.9 GALVANIZED	VIS 8X25 5933 10.9 ZN	SCHRAUBE 8X25 5933 10.9 ZN	TORNILLO 8X25 5933 10.9 ZN
5	F01090203	VIT.M 6X 1X 20 U5449 ZN	SCREW M 6X 1X 20 U5449 Z	VIS M 6X 1X 20 U5449 ZG	SCHRAUBE M 6X 1X 20 U5449	TORNIL. M 6X 1X 20 U5449
6	G16720110	MONT.COPRITRAMOGGIA VERATRIS				
7	F01020404	VITE M 6X 1X20 U5739 8.8 ZN	BOLT 6X20 5739 8.8 GALVANIZED	VIS 6X20 5739 8.8 ZN	SCHRAUBE 6X20 5739 8.8 ZN	TORNILLO 6X20 5739 8.8 ZN
8	F02250705	OCCHIELLO AGGANCIO ART.360	HOOK EYE	OEILLET D'ACCROCHAGE	KUPPLUNGSTSE	ARGOLLA DE ENGANCHE
9	F01020362	VITE M 4X0,7X 12 U5739 8.8 ZN	SCREW 4X12 5739 8.8 GALVANIZED	VIS 4X12 5739 8.8 ZN	SCHRAUBE 4X12 5739 8.8 ZN	TORNILLO 4X12 5739 8.8 ZN
10	F05150495	TIRANTE IN GOMMA	COUPLING TIE ROD	TRINGLE D'ATTELAGE	KUPPLUNGSSPANNSTANGE	TIRANTE DE ENGANCHE
11	F02250706	PIASTRINA ATTACCO GANCIO	HOOK FIXING PLATE	PLAQUETTE ATTELAGE CROCHET	ANSCHLUSSPLZTTCHEN HAKEN	PLAQUETA CONEXIN GANCHO P
12	G17920030	ANELLO DI FISSAGGIO	RING	BAGUE	RING	ANILLO
13	G17920041	GUARNIZIONE				
14	F01230016	DADO M 4X 0,7 D982 8 ZN	NORM.SELF-LOCKING NUT 4 GALVAN	ECROU AUTOB.NOR.4 ZN	SELBSTSP. MUTTER NOR. 4 ZN	TUERCA AUTOB. NOR. 4 ZN
15	G17920212	DISTRIBUTORE 40 U.				
16	F01420048	ROS.M8 8,4X 24X 2 U6593 ZN	PLANE WASHER D.8	RONDELLE D.8	SCHEIBE D.8	ARANDELA D.8
17	F01220022	DADO M 8X1,25 D980 8 ZN	NUT M8X 1,25 D980 8 ZN	ECROU M8X 1,25 D980 8 ZN	MUTTER M8X 1,25 D980 8 ZN	TUERCA M8X 1,25 D980 8 ZN
70	G16022670	CARTER DISTRIBUTORE	DISTRIBUTOR CASE	CARTER DISTRIBUTEUR	VERTEILER GEHZUSE	CARTER DISTRIBUIDOR
19	F03011139	GUARNIZIONE D.70	SEAL D.70	GARNITURE D.70	DICHTUNG D.70	JUNTA D.70
20	F01020012	VITE M 4X0,7X 40 U5737 8.8 ZN	BOLT 4X40 5737 8.8 GALVANIZ.	VIS 4X40 5737 8.8 ZN	SCHRAUBE 4X40 5737 8.8 ZN	TORNILLO 4X40 5737 8.8 ZN
21	F01420036	ROS.M6 6,4X 18X 2 U6593 ZN	FLAT WASHER 6-6X 18X2 6593 ZN	ROND. PLATE 6-6X 18X2 6593 ZN	SCHEIBE 6-6X 18X2 6593 ZN	ARAND. PLANA 6-6X 18X2 6593 ZN
22	F01220011	DADO M 6X 1 D980 8 ZN	NUT M6X1 D980 8 ZN	ECROU M6X1 D980 8 ZN	MUTTER M6X1 D980 8 ZN	TUERCA M6X1 D980 8 ZN
23	F01020449	VITE M 8X1,25X35 U5739 8.8 ZN	BOLT M 8X35	VIS M 8X35	SCHRAUBE M 8X35	TORNILLO M 8X35
24	G19005150	GUARNIZIONE FORO D.45 CHIUSO	CLOSED HOLE D.45 GASKET	JOINT TROU D.45 FERM+	DICHTUNG IFFNUNG D.45 GESCHLO	JUNTA AGUJERO D.45 CERRADO
25	F02300020	FASCETTA STRING. 32/50 H.9	STRING FASTEN.STRAP 32/50 H.9	COLLIER 32/50 H.9	SHELLE 32/50 H.9	ABRAZADERA 32/50 H.8
26	G17921470	ASS.TRAMOGGIA 1500L				
27	G16125181	MONT.DOSAT.SEME STAGNO SX FL.P				
28	G17920220	CONO DISTRIBUTORE 40 USCITE	DIFFUSOR	DIFFUSEURS	DIFFUSOREN	DIFUSORES
29	G68005034	CORPO	CASING	CORPS	KTRPER	CUERPO
30	G17921560	ASS.TUBO MISCELATORE				
31	G17921580	LAMA SUPP.TUBO MISCELATORE				
32	G17920301	GRIGLIA DI PROTEZIONE	PROTECTION GRID STOP	ARRET GRILLE DE PROTECTION	FESTSTELLVORRICHTUNGSSCHUTZGITT	BLOQUEO REJILLA DE PROTECCION
33	F01020436	VITE M 8X1,25X 20 U5739 8.8 ZN	SCREW M8X1,25X20 U5739 8.8 ZN	VIS M8X1,25X20 U5739 8.8 ZN	SCHRA. M8X1,25X20 U5739 8.8 ZN	TORN. M8X1,25X20 U5739 8.8 ZN
34	G19005140	GUARNIZIONE FORO D.45	HOLE D.45 GASKET	JOINT D.45 FERME	DICHTUNG D.45 GESCHLO	JUNTA AGUJERO D.45
35	G16720090	SUPPORTO SUP.COPRITRAMOGGIA	UPPER HOPPER COVER SUPPORT	SUPPORT SUP. COUVRE-TREMIE	OB.HALTERUNG TRICHTERABDECKUN	SOPORTE SUP. CUBIERTA TOLVA
36	G10111530	CORDA POLIPROPILENE 12X2400				
37	G66248098	TAPPO CONVOGLIATORE DEPR. SP	AIR PUMP CONVEYOR PLUG SP	BOUCHON CONVOYEUR TURBINE SP	VAKUUM FTRDERPFROPFEN SP	TAPN CONDUCTOR DEPR. SP D
38	F03100530	TUBO EOLO PU-P D.32	SATURNO PIPE PU-P D.32	TUBE SATURNO PU-P D.32	ROHR SATURNO PU-P D.32	TUBO SATURNO PU-P D.32
39	G68005136	COPERCHIO DISTRIBUTORE 48 U. >				
40	G17921250	DISTRIBUTORE 48U.MODIFICATO				
41	G16121410	COPERCHIO DISTRIBUTORE 33U.ALL	DISTRIBUTOR COVER 33 OUTPUTS	COUVERCLE DISTRIBUTEUR 33 SORT	DECKEL SZAPPARAT 33 AUSGZNG	TAPA DISTRIBUIDOR 33 SALIDAS
42	G16121401	DISTRIBUT.33 U. D.140-150 UNIF				
43	G22270213	BOCCOLA LEVA CAMBIO 35 SP	BUSHING- 35 GEAR LEVER SP	BOITE LEVIER BOITE DE VITESSE	BsCHSE GETRIEBEBEBEL 35 SP	CASQUILLO PALANCA CAMBIO 35
44	G16720100	SUPP.CENTRALE COPRITRAMOGGIA	CENTRAL SUPPORT	SUPP.CENTR.	MITTELALTERUNG	OP.CENTRAL
45	G16720080	RINFORZO CENTRALE COPRITRAM.	CENTRAL REINFORCEMENT	REINFORCEMENT CENTR.	MITTELVERSTZRKUNG	REFUERZO CENTRAL
46	G20970142	RONDELLA 32X4X15,5	WASHER 32X4X15-5	RONDELLE 32X4X15-5	UNTERLEGSCHIEBE 32X4X15-5	ARANDELA 32X4X15-5
47	G16021710	SUPPORTO LATER.COPRITRAM.	SIDE SUPPORT	SUPPORT LATERAL	SEITLICHE HALTERUNG	SOPORTE LATERAL
48	G16720120	TELO COPRITRAMOGGIA VERATRIS	HOPPER COVER-SHEET	TOILE COUVRE-TREMIE	TRICHTERABDECKTUCH	ONA PROTEC. TOLVA
49	G16021770	FERMO LATERALE TELO COPRITRAM.	STOP	ARRET	FESTSTELLVORRICHTUNG	BLOQUEO
50	F01020440	VITE M 8X1,25X25 U5739 8.8 ZN	BOLT M8 X25 5739 8.8 ZN	VIS M8 X25 5739 8.8 ZN	SCHRAUBE M8 X25 5739 8.8 ZN	TORNILLO M8 X25 5739 8.8 ZN
51	F01220022	DADO M 8X1,25 D980 8 ZN	NUT M8X 1,25 D980 8 ZN	ECROU M8X 1,25 D980 8 ZN	MUTTER M8X 1,25 D980 8 ZN	TUERCA M8X 1,25 D980 8 ZN
52	F01030060	VITE M 8X1,25X35 U5933 10.9 ZD	BOLT 8X35 5933 8.8 GALVANIZ.	VIS 8X35 5933 8.8 ZN	SCHRAUBE 8X35 5933 8.8 ZN	TORNILLO 8X35 5933 8.8 ZN
53	G16022450	CHIUSURA ESCL.FILE MANUALE				
54	G17920051	RIALZO TRAMOGGIA				
55	F01020432	VITE M 8X1,25X16 U5739 8.8 ZN	BOLT M 8X16	VIS M 8X16	SCHRAUBE M 8X16	TORNILLO M 8X16
56	F07100132	MOUSSE ADESIVA MM 5X3				
57	G66248223	TAPPO SUPP.SPAND.D.11	PLUG MAN. SPR. SUPP. D.11	BOUCHON SUPPORT EP. ENGRAIS D.	HALTERUNGSPFROPFEN DsNGERSTR.	TAPN SOPORTE ABON.D.11 D
58	G19707240	TABELLA DI DISTRIBUZIONE				

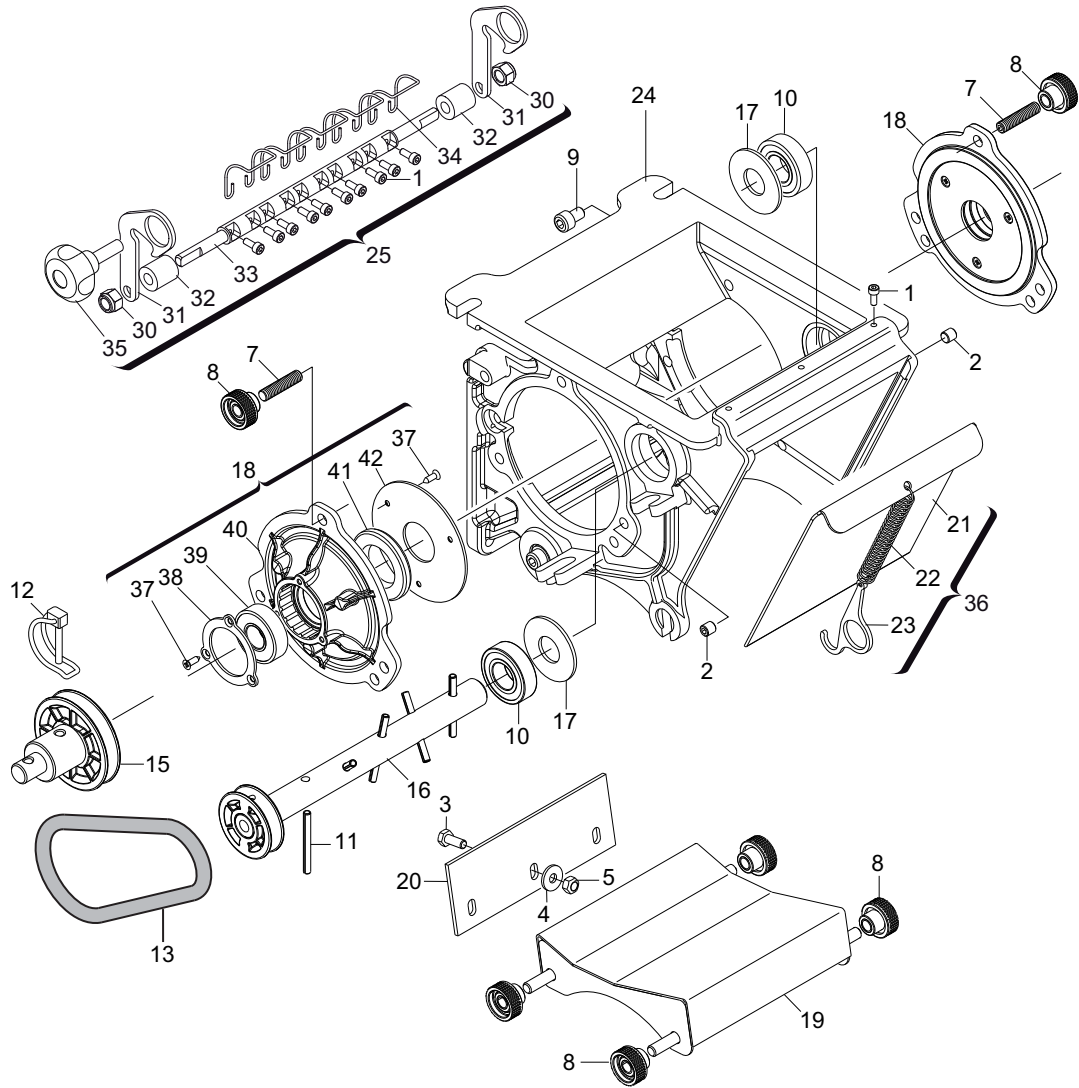

**Semente Normale
Normal Seeds**

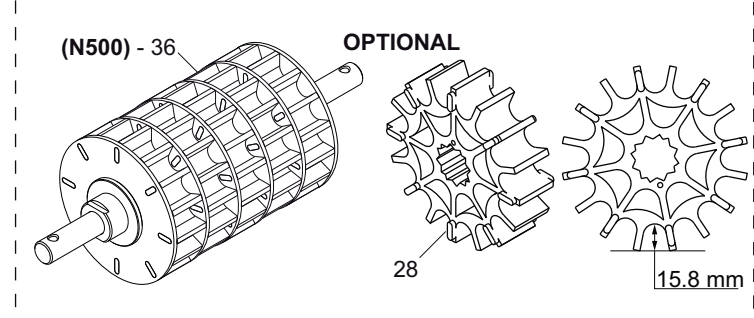
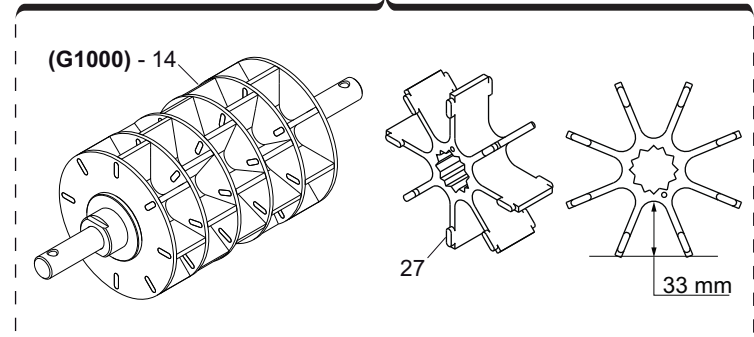

**Semente Piccola
Small Seeds**

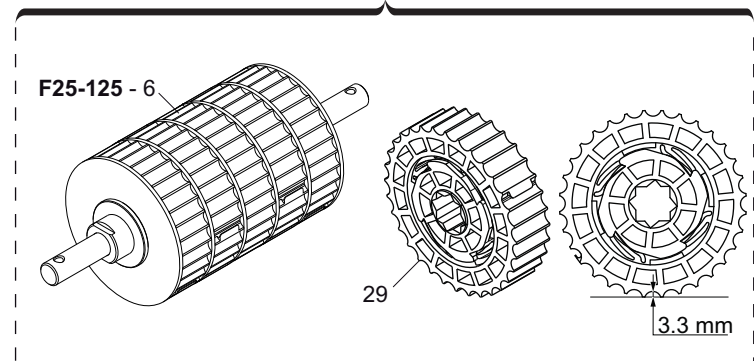

DOSATORE

TAV. 080

Pos.	Cod.	Descrizione	Description	Description	Benennung	Descripcion
1	F01040026	VITE M 4X 0,7X10 U5931 A2 IX	SCREW 4X10 5931 INOX A2	VIS 4X10 5931 INOX A2	SCHRAUBE 4X10 5931 INOX A2	TORNILLO 4X10 5931 INOX A2
2	F01050037	VIT.M 8X1,25X 10 U5923 8.8 BR				
3	F01020419	VITE M 6X1 X 16 U5739 A2 IX	BOLT M6 X1 X 16 U5739 8.8 IX	VIS M6 X1 X 16 U5739 8.8 IX	SCHRAUBE M6 X1 X 16 U5739 8.	TORNIL. M6 X1 X 16 U5739 8.8
4	F01420038	ROS.M6 6,4X 18X 2 U6593 IX	WASHER M6 6,4X18X2 U6593 IX	RONDELLE M6 6,4X18X2 U6593 IX	SCHIEBE M6 6,4X18X2 U6593 IX	ARANDELA M6 6,4X18X2 U6593 IX
5	F01230024	DADO M 6X 1 D982 A2 IX	NORM.SELF-LOCKING NUT 10	ECROU AUTOB.NOR.10	SELBSTSP.MUTTER NOR. 10	TUERCA AUTOB. NOR. 10
6	G16123820	MONT.RULLO F25-125 ELEFANTE				
7	F01050040	VIT.M 8X1,25X 35 U5923 A2 IX				
8	F06220037	VOLANTINO ZIGR.D.26-M8 FEM	KNURLED FLYWHEEL D.26-M8 FEM	VOLANT CANNEL+ D.26-M8 FEM	GER-ND. HANDRAD D.26-M8 FEM	VOLANTE ESTR. Ī26-M8 FEM
9	F01040090	VITE M 8X1,25X18 U5931 A2 IX	SCREW M8X1,25X 18 U5931 IX A2	VIS M8X1,25X 18 U5931 IX A2	SCHRAUBE M8X1,25X 18 U5931 IX	TORNIL. M8X1,25X 18 U5931 IX
10	F04010132	CUSC.d20 D42 B12 6004 2RSIX	BEARING d20 D42 B12 6004 2R	PALIER d20 D42 B12 6004 2RS	LAGER d20 D42 B12 6004 2RSI	COJINETE d20 D42 B12 6004 2
11	F02100316	SPINA EL.5 X50 DIN 1481 INOX				
12	F02200595	SPINOTTO X INGRANAGGIO				
13	F03011142	GUARNIZIONE OR 10 X 100 EPDM	O-RING GASKET 10X100	JOINT TORIQUE 10X100	DICHTUNG OR 10X100	JUNTA TĒRICA OR 10X100
14	G16123750	MONT.RULLO G1000 ELEFANTE				
15	G16125241	MONT.ALBERO TRASCIN.RULLO				
16	G16124421	MONT.ALBERO AGITATORE				
17	G18701920	RONDELLA 20X48X2,5	WASHER 20X48X2,5	RONDELLE 20X48X2,5	UNTERLEGSCHIEBE 20X48X2,5	ARANDELA 20X48X2,5
18	G16124511	MONT.FLANGIA PORTA CUSC.RULLO				
19	G16125261	ASS.SCIVOLO INFERIORE RULLO IX				
20	G16124600	TASTATORE IN GOMMA				
21	G16060160	SPORTELLO GRANDE INOX	LARGE HATCH	PORTILLON GRAND	GROSSE Klappe	PORTILLO GRANDE
22	G18904170	MOLLA SPORTELLO GRANDE	LARGE HATCH SPRING	RESSORT PORTILLON GRAND	GROSSE Klappe FEDER	MUELLE DE PORTILLO GRANDE
23	G16060170	GANCIO INOX	HOOK	CROCHET	HAKEN	GANCHO
24	G16125151	CORPO DISTRIB.STAGNO ALLUMINIO				
25	G16060040	PULITORE COMPL	ANTI CLOGGING	ANTI-ENGORGEMENT	VERSTOPFUNGSHEMMENDES EL.	ANTI OBSTRUCCIN
26	G16123830	MONT.RULLO N500 ELEFANTE				
27	G16063060	RUOTA G200				
28	G16063100	RUOTA N100				
29	G16063030	RUOTA F25				
30	F01230032	DADO M 8X1,25 D982 A2 IX	NUT M 8X1,25 D982 A2 IX	ECROU M 8X1,25 D982 A2 IX	MUTTER M 8X1,25 D982 A2 I	TUERCA M 8X1,25 D982 A2 I
31	G16060210	LEVA ALBERO PULITORE	LEVER	LEVIER	HEBEL	PALANCA
32	G18802500	BUSSOLA BRONZO 17X8X19	BOLT 17X8X19	BOULON 17X8X19	SCHRAUBE 17X8X19	PERNO 17X8X19
33	G16060220	ALBERO PULITORE INOX	ANTI CLOGGING SHAFT	ARBRE ANTI-ENGORGEMENT	WELLE VERSTOPFUNGSHEMMENDES	EJE ANTI OBSTRUCCION
34	G18904160	MOLLA PULITORE	ANTI CLOGGING SPRING	RESSORT ANTI-ENGORGEMENT	VERSTOPFUNGSHEMMENDES FEDER	MUELLE DE ANTI OBSTRUCCION
35	F06220019	VOLANTINO 4LOBI D.40-M 8X25	4-LOBE HANDWHEEL M8X25	VOLANT 4 LOBES M8X25	HANDRAD 4 BUCKEL M8X25	VOLANTE 4 LOBI M8X25
36	G16060050	SPORTELLO GRANDE COMPL.	COMPL. LARGE HATCH	PORTILLON GRAND COMPL.	GROSSE Klappe KOMPL.	PORTILLO GRANDE COMPL.
37	F01070122	VIT.A.3,9X1,34X 13 6955 4.8NI	SCREW 3,9X1,34X13 U6955 4.8 ZN	VIS 3,9X1,34X13 U6955 4.8 ZN	SCHR. 3,9X1,34X13 U6955 4.8 ZN	TORN. 3,9X1,34X13 U6955 4.8 ZN
38	G16126880	FERMO CUSCINETTO IX				
39	F04010161	CUSC.D17 D40 B12 6203 2RS EX	BEARING 6203	ROULEMENT 6203 2RS	LAGER 6203 2RS	COJINETE 6203 2RS SKF
40	G19006430	SUPP.CUSC.RULLO DOSAT.GRINTA S				
41	F03010062	ANEL. T.A 30X 52X 7 HMS4R >				
42	G16125691	PROTEZIONE POST.PARAPOLVERE IX				

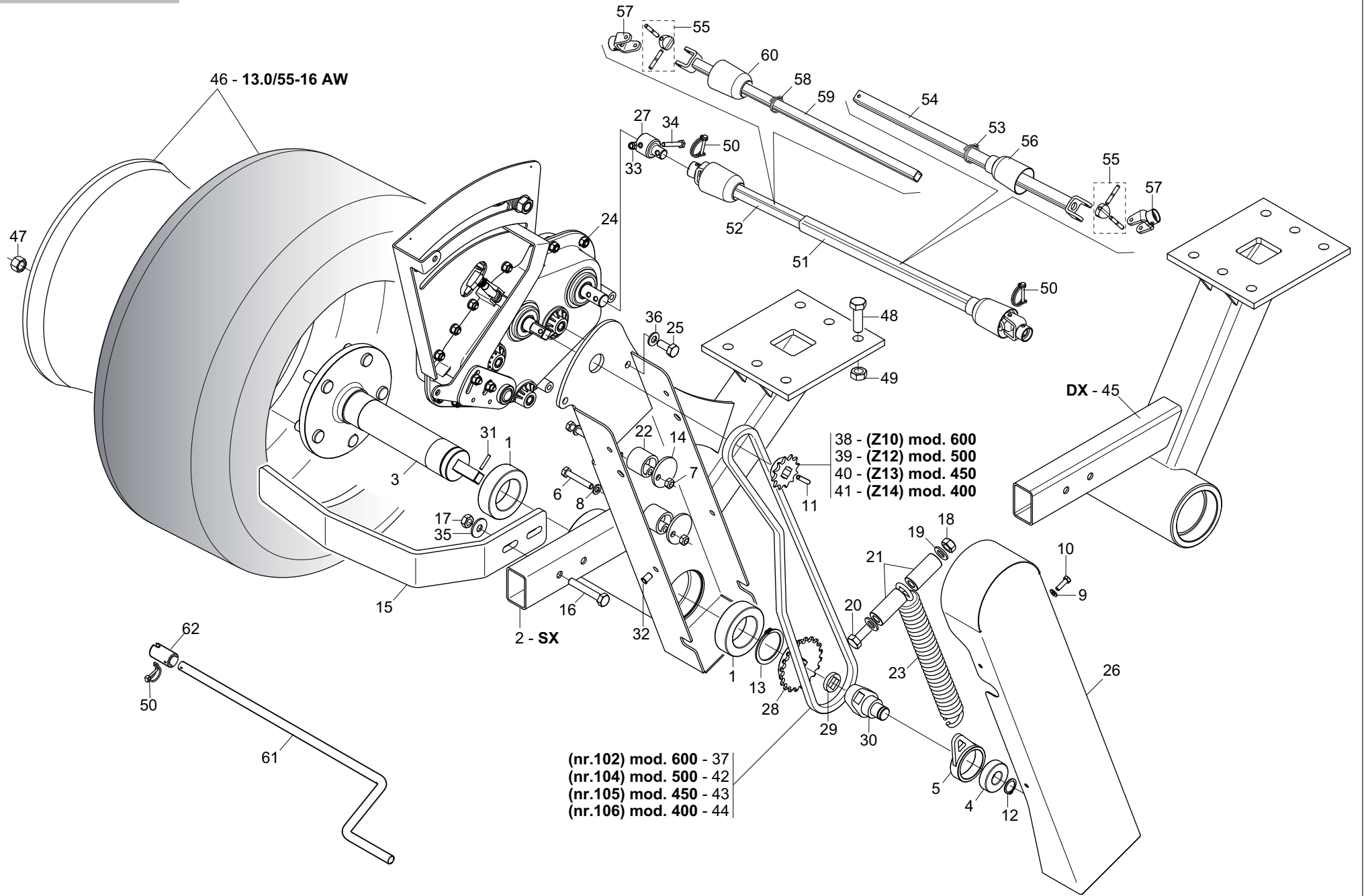

RUOTA E TRASMISSIONE

TAV. 090

Pos.	Cod.	Descrizione	Description	Description	Benennung	Descripcion
1	F04010347	CUSC.D50 D80 B23 63010 2RS1>	BEARING D50 D80 B23 63010 2RS1	PALIER D50 D80 B23 63010 2RS1	LAGER D50 D80 B23 63010 2RS1	COJINET.D50 D80 B23 63010 2RS1
2	G17931680	ASS.SUPP.RUOTA TRASMISSIONE				
3	G17931790	MONT.ASSE RUOTA ZN				
4	F04010163	CUSC.d20 D47 B14 6204				
5	G17931770	ASS.FERMO RUOTA ZN				
6	F01020072	VITE M 8X1,25X50 U5737 8.8 ZN	SCREW M8X1,25X50 U5737 8.8 ZN	VIS M8X1,25X50 U5737 8.8 ZN	SCHR. M8X1,25X50 U5737 8.8 ZN	TORN. M8X1,25X50 U5737 8.8 ZN
7	F01220022	DADO M 8X1,25 D980 8 ZN	NUT M8X 1,25 D980 8 ZN	ECROU M8X 1,25 D980 8 ZN	MUTTER M8X 1,25 D980 8 ZN	TUERCA M8X 1,25 D980 8 ZN
8	F01410051	ROS.M8 8,4X 17X1,6 U6592 ZN	WASHER M8 8,4X17X1,6 U6592 ZN	RONDEL. M8 8,4X17X1,6 U6592 ZN	SCHEIBE M8 8,4X17X1,6 U6592 ZN	ARANDELA M8 8,4X17X1,6 U6592 ZN
9	F01410037	ROS.M6 6,4X12,5X1,6 U6592 ZN	PLANE WASHER D.6	RONDELLE D.6	SCHEIBE D.6	ARANDELA D.6
10	F01020404	VITE M 6X 1X20 U5739 8.8 ZN	BOLT 6X20 5739 8.G GALVANIZED	VIS 6X20 5739 8.G ZN	SCHRAUBE 6X20 5739 8.G ZN	TORNILLO 6X20 5739 8.G ZN
11	F02100114	SPINA E.P. 6X 30 U6873 C70 BR	ELASTIC PIN 6X30	GOIJON ELASTIQUE 6X30	SPANNHUELSE 6X30	ESPINA ELASTICA 6X30
12	F02050078	ANELLO E. DE 20X 1,2 U7435 C70	SEEGER RING E. 20X1,2 7435 C70	SEEGER 20X 1,2 U7435 C70	SEEGER E. 20X 1,2 U7435 C70	
13	F02050203	ANELLO E. DE 50X 2 U7435 C70	SEEGER RING D50X2 U7435 C70	ANEL SEEGER D50X2 U7435 C70	SEEGER RING D50X2 U7435 C70	ANILLO SEEGER D50X2 U7435 C70
14	G18701470	RONDELLA 9X48X4 SC.ZN	WASHER 9X48X4 SC.ZN	RONDELLE 9X48X4 SC.ZN	UNTERLEGSSCHEIBE 9X48X4 SC.ZN	ARANDELA 9X48X4 SC.ZN
15	G17914470	RASCHIATERRA	SOIL SCRAPER	RACLEUR	ERDSCHABER	RASCADOR DE TIERRA
16	F01020120	VIT.M10X 1,5X 65 U5737 8.8 ZN	SCREW M10X1,5X65 U5737 8.8 ZN	VIS M10X1,5X65 U5737 8.8 ZN	SCHRA. M10X1,5X65 U5737 8.8 ZN	TORN. M10X1,5X65 U5737 8.8 ZN
17	F01220033	DADO M10X 1,5 D980 8 ZN	NUT M10X 1,5 D980 8 ZN	ECROU M10X 1,5 D980 8 ZN	MUTTER M10X 1,5 D980 8 ZN	TUERCA M10X 1,5 D980 8 ZN
18	F01220048	DADO M12X1,75 D980 8 ZN	NUT M12X1,75 D980 8 ZN	ECROU M12X1,75 D980 8 ZN	SCHEIBE M12X1,75 D980 8 ZN	TUERCA M12X1,75 D980 8 ZN
19	F01410076	ROS.M12 13X 24X2,5 U6592 ZN	PLANE WASHER D12 UNI 6592 ZN	RONDELLE D12 UNI 6592 ZN	SCHEIBE D12 UNI 6592 ZN	ARANDELA D12 UNI 6592 ZN
20	F01020179	VITE M12X1,75X150 5737 8.8 ZN	SCREW M12X1,75X150 5737 8.8 ZN	VIS M12X1,75X150 5737 8.8 ZN	SCHRA.M12X1,75X150 5737 8.8 ZN	TORN. M12X1,75X150 5737 8.8 ZN
21	G18801460	BOCCOLA 12,25X25 X54 ZN	BUSHING 12.25 X 25 X 54- GALVA	BOITE 12-25X25 X54 ZN	BsSCHSE 12-25X25 X54 ZN	CASQUILLO 12-25X25 X54 ZN
22	G66248207	TENDICATENA SPAND. SP-520	CHAIN TENSIONER	TENDEUR DE CHAINE EPAND. ENGR.	KETTENSPENNER DsNGERSTR. SP-52	SENSOR DE CADENA ABON. SP-520
23	G65337004	MOLLA TRAZ.SOLLEV. FU	TRACTION SPRING LIFT. FU	RESSORT TRACT. LEVAGE FU	ZUGFEDER HEBUNG FU	MUELLE TRAC. LEVDEL. FU
24	G16930920	MONT.SCATOLA CAMBIO CONC.PLA				
25	F01020470	VITE M10X 1,5X20 U5739 8.8 ZN	BOLTM 10X20	VIS M 10X20	SCHRAUBE M 10X20	TORNILLO M 10X20
26	G17931730	ASS.SUPP.CARTER				
27	G17931630	ASSE UNIONE CAMBIO ZN				
28	G07002547	INGRANAGGIO R.L. Z.20 SX	FREE WHEEL GEAR Z-20 RIGHT	ENGRENAGE ROUE LIBRE Z-20 DRT.	ZAHNRAD FREILAUF Z-20 RECHTER	ENGRANAJE R.LIBRE Z-20 DER.
29	G66248218	RONDELLA DISTAN.SPAND.	MAN. SPR. SPACER WASHER	RONDELLE ENTRETOISE EP. ENGRAI	ABSTANDSCHEIBE DsNGERSTREUER	ARANDELA DISTAN.ABONAD.
30	G17931760	ASS.SUPP.CUSCINETTO ZN				
31	F02100062	SPINA E.P. 4X 24 U6873 C70 BR	PIN EL. 4 X24 DIN 1481	FICHE EL. 4 X24 DIN 1481	SPANNSTIFT 4 X24 DIN 1481	CLAVIJA EL.4 X24 DIN 1481
32	F02250680	INSERTO FIL.M 6X13 ZN T.RIDOTT	THREADED INSERT M6X13 ZN	PIECE INTERC.FILETEE M 6X13ZN	GEWINDEEINSATZ M 6 X 13 ZN	ENCASTRE ROSCADO M 6 X13 ZN
33	F01230022	DADO M 6X 1 D982 8 ZN	NORM.SELF-LOCKING NUT 6 GALVAN	ECROU AUTOB.NOR.6 ZN	SELBSTSP.MUTTER NOR.6 ZN	TUERCA AUTOB. NOR. 6 ZN
34	F01020040	VITE M 6X 1X 40 U5737 8.8 ZN	BOLT 6 X40 5737 8.G GALVANIZED	VIS 6 X40 5737 8.G ZN	SCHRAUBE 6 X40 5737 8.G ZN	TORNILLO 6 X40 5737 8.G ZN
35	F01420060	ROS.M10 10,5X 30X2,5 U6593 ZN	WASHER 10,5X30	RONDELLE 10,5X30	SCHEIBE 10,5X30	ARANDELA 10,5X30
36	F01430023	ROS.M10 10,5X 18X0,9 U8842J ZN	WASHER D10 DIN 6798 D.INT.ZN	RONDELLE D10 DIN 6798 D. INT.	UNT. SCHEIBE D10 DIN 6798 D.INT	ARANDELA D10 DIN 6798 D.INT.ZN
37	F06080054	CATENA 1/2 ISO 083 102 MAGLIE	CUT-DOWN CHAIN 1/2 ISO 083 102	TR. CH.1/2 ISO 083 102 MAILLES	KETTENZNGE 1/2 ISO 083 102 G	TRECHO CADENA 1/2 ISO 083 102
38	G22250006	INGR.CON MOZZO 1/2 Z-10 SV	GEARS- W/ HUB 1/2 Z-10 SV	ENGRENAGE AVEC MOYEU 1/2 Z-10	ZAHNRAD MIT NABE 1/2 Z-10 SV	ENGRAN.CON PERNO 1/2 Z-10 SV
39	G20860086	INGRANAGGIO 1/2 Z-12 F.Q.	GEAR 1/2 Z-12 F.Q.	ENGRENAGE 1/2 Z-12 TROUS CARRE	ZAHNRAD 1/2 Z-12 F.Q.	ENGRANAJE 1/2 Z-12 F.Q.
40	G15131050	PIGNONE Z13	Z-13 PINION	PIGNON Z13	RITZEL Z-13	Pi¼N Z13 P
41	G16034980	PIGNONE Z14 1/2-3/16Q.16,4 ZN				
42	F06080134	CATENA 1/2 ISO 084 104 MAGLIE				
43	F06080056	SP.CAT.1/2-3/16 105M.ISO 083-1				
44	F06080109	CATENA 1/2 ISO 084 106 MAGLIE	CHAIN 1/2-3/16 106 LINKS DIN81	CHAINE .1/2-3/16 106M.DIN8187	KETTE 1/2-3/16 106 G.DIN8187	CAD.1/2-3/16 106 ESLAB.DIN8187
45	G17930210	SUPPORTO RUOTADX	LEFT WHEEL SUPPORT	SUPPORT ROUE GCH.	LINKE RADHALTERUNG	SOPORTE RUEDA IQZ.
46	F06120085	RUOTA COMPL.13.0/55-16 AW	COMPL. WHEEL 13.0/55-16 AW	ROUE COMPL. 13.0/55-16 AW	RAD KOMPL.13.0/55-16 AW	RUEDA COMPL.13.0/55-16 AW
47	F01250046	DADO COLON. 16X1,5 ZN				
48	F01020198	VITE M14X 2X 45 U5737 8.8 ZN	BOLT 14X45 5737 8.G GALVANIZ.	VIS 14X45 5737 8.G ZN *	SCHRAUBE 14X45 5737 8.G ZN *	TORNILLO 14X45 5737 8.G ZN *
49	F01220255	DADO M14X 2 D980 8 ZN	NUT- TRISTOP M14X2 D980 8 ZN	ECROU TRISTOP M14X2 D980 8 ZN	MUTTER TRISTOP M14X2 D980 8 ZN	TUERCA TRISTOP M14X2 D980 8 ZN
50	F02200595	SPINOTTO X INGRANAGGIO				
51	G16032310	CARDANO Q.25 L.400 COMPL.	CARDAN Q.25 L.400 COMPL.	CARDAN Q.25 L.400 COMPL.	KARDAN Q.25 L.400 COMPL.	CARDANO Q.25 L.400 COMPL.
52	G17330230	CARDANO LATO DISTRIB.COMPL.	COMPL. CARDAN ON DISTRIB. SIDE	CARDAN CÉT+ DISTRIBUTEUR COMPL	KARDANWELLE STREUERSEITE KOMPL	CARD-N LATO DISTRIB.COMPL.
53	F02300018	FASCETTA STRING. 25/40 H.8	STRING FASTEN.STRAPS 25/40 H.8	COLLIER DE SERRAGE 25/40 H.8	SHELLE 25/40 H.8	ABRAZADERA 25/40 H.8
54	G16032660	TUBO CARDANO Q.25 L.400	CARDAN TUBE Q.25 L.400	TUBE CARDAN Q.25 L.400	KARDANROHR Q.25 L.400	TUBO CARDAN Q.25 L.400
55	G19001610	CROCIERA SP				
56	G19002840	COPRICARDANO SUPERIORE	TOP CARDAN JOINT COVER	COUVRE-CARDAN SUPERIEUR	OBERE KARDANABDECKUNG	CUBRECARDæN SUPERIOR
57	G19204060	FORCELLA				
58	F02300017	FASCETTA STRING. 20/32 H.9	STRING FASTEN STRAPS 20/32 H.9	COLLIER DE SERRAGE 20/32 H.9	SHELLE 20/32 H.9	ABRAZADERA 20/32 H.9
59	G17330220	TUBO CARDANO Q.20 L.330	CARDAN TUBE Q.20 L.330	TUBE CARDAN Q.20 L.330	KARDANROHR Q.20 L.330	TUBO CARDAN Q.20 L.330
60	G66248094	COPRICARDANO SP	UNIVERSAL JOINT COVER SP	COUVRE-CARDAN SP	KARDANABDECKUNG SP	CUBRECARDæN SP
61	G16040930	ASTA MANIGLIA PROVA SEMINA ZN	SEEDING TEST HANDLE SHAFT ZN	TIGE POIGN+E ESSAI SEMIS ZN	STANGE ABDREHPROBENKURBEL ZN	BARRA MANILLA PRUEBA SIEMBRA Z
62	G16040940	BOCCOLA MANIGLIA ZN	HANDLE BUSH ZN	DOUILLE POIGN+E ZN	BUCHSE KURBEL ZN	MANGUITO MANILLA ZN

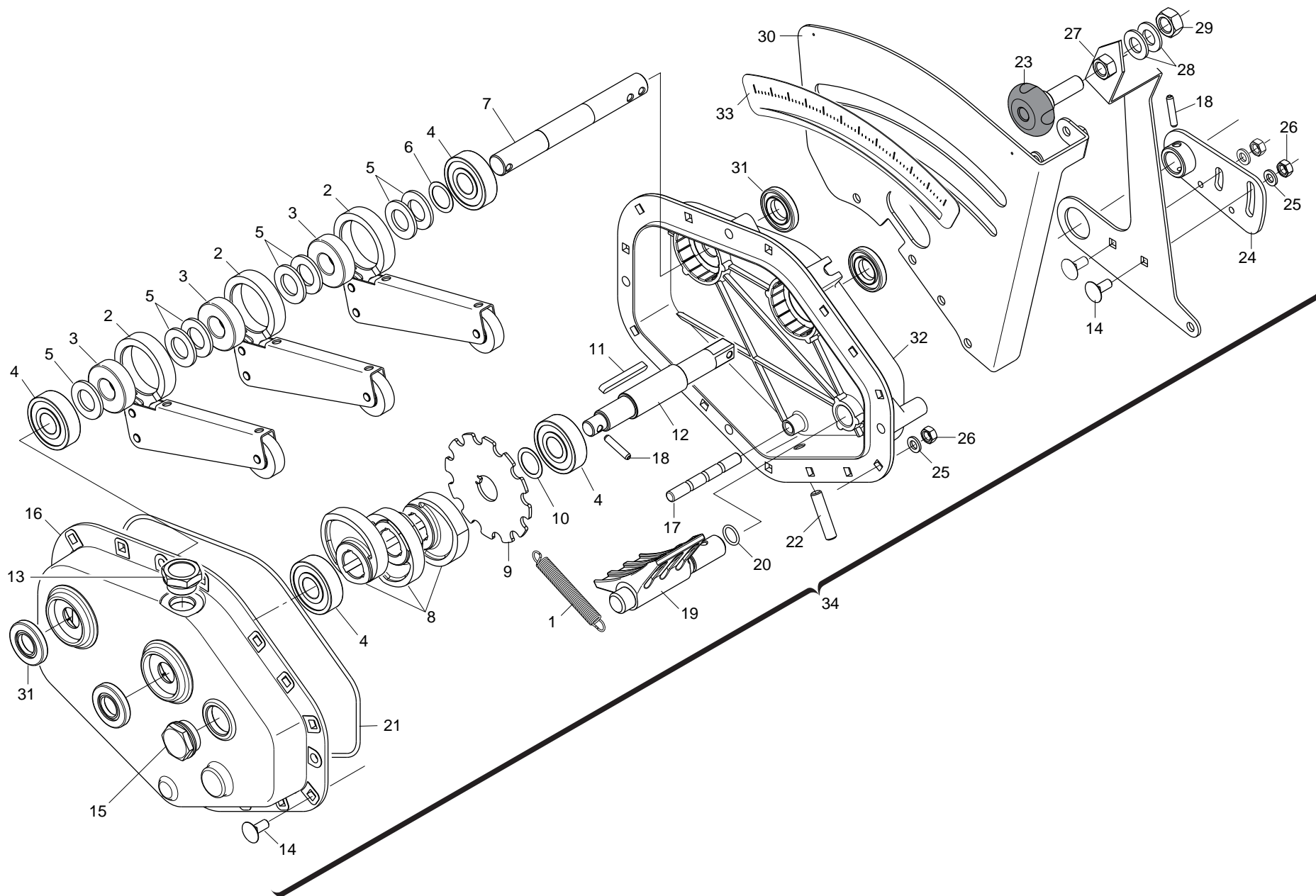

CAMBIO

TAV. 100

Pos.	Cod.	Descrizione	Description	Description	Benennung	Descripcion
1	G18903290	MOLLA TRAZ.CAMBIO M	TRACTION SPRING- GEARS M	RESSORT TRACT. BOITE VITESSE M	ZUGFEDER GETRIEBE M	MUELLE TRAC. CAMBIO M
2	G07000006	RIBADITURA BIELLA	CONNECTING ROD RIVETING	RIVETAGE BIELLE	PLEUEL EINNIETEN	REMACHADO BIELA
3	F06120065	RUOTA LIBERA KK20	FREE WHEEL KK20	ROUE LIBRE KK20	FREILAUF KK20	RUEDA LOCA KK20
4	F04010207	CUSC.D20 D52 B15 6304 Z	BEARING d20 D52 B15 6304 Z	PALIER d20 D52 B15 6304 Z	LAGER d20 D52 B15 6304 Z	COJINETE d20 D52 B15 6304 Z
5	F01410124	ROS.M20 21X 37X 3 U6592 ZN	WASHER M20 21X37X3 U6592 ZN	RONDELLE M20 21X37X3 U6592 ZN	SCHEIBE M20 21X37X3 U6592 ZN	ARANDELA M20 21X37X3 U6592 ZN
6	G20970100	RONDELLA 30X0,5X22 ACC.	WASHER 30X0-5X22 ACC.	RONDELLE 30X0-5X22 ACIER	UNTERLEGSCHIEBE 30X0-5X22 ACC.	ARANDELA 30X0-5X22 ACC.
7	G16230530	ALBERO RUOTA LIBERA C.PLA BON.				
8	G07000014	CAMMA CAMBIO BAGNO OLIO	OIL BATH GEARBOX CAM	CAME BOITE DE VIT. BAIN HUILE	NOCKEN GETRIEBE TLBAD	LEVA CAMBIO BA%O ACEITE
9	G16230520	RUOTA FONICA				
10	F01440079	ROND.RASAM.26,2X34,8X0,5 IX	WASHER D.26,2X34,8X0,5	RONDELLE D.26,2X34,8X0,5	UNTERLEGSCHIEBE D.26,2X35X0,5	ARANDELA D.26,2X34,8X0,5
11	F02150040	LINGUETTA 6X 6X 55 U6604A	TAB 06X6X55 UNI 6604A	LANGUETTE 06X6X55 UNI 6604/A	FEDERKEIL 06X6X55 UNI 6604/A	LENGSETA 06X6X55 UNI 6604/A
12	G16930930	ALBERO CAMMES CAMBIO PLA ZN				
13	F03150706	TAPPO OLIO 3/4" MODELLO TC/6				
14	F01060040	BUL.M 8X1,25X 20 U5732 4.6 ZG	BOLT 8 X20 5732 4.6 GALVANIZED	VIS 8 X20 5732 4.6 ZN	SCHRAUBE 8 X20 5732 4.6 ZN	TORNILLO 8 X20 5732 4.6 ZN
15	F03150736	TAPPO LIVELLO M30X1,5 HFE 22	OIL LEVEL PLUG M30X1,5 HFE 22	BOUCHON NIV. M30X1-5 HFE 22	STANDSCHRAUBE M30X1-5 HFE 22	TAPN NIVEL M30X1-5 HFE 22 D
16	G19005720	COPERCHIO CAMBIO				
17	G16230550	PERNO SUPPORTO MOLLE				
18	F02100114	SPINA E.P. 6X 30 U6873 C70 BR	ELASTIC PIN 6X30	GOUJON ELASTIQUE 6X30	SPANNHUELSE 6X30	ESPINA ELASTICA 6X30
19	G16230560	REGOLATORE CAMBIO				
20	F03010390	ANELLO OR 15,08X2,26 NBR	O-RING 119	GARNITURE OR 119	DICHTUNG OR 119	JUNTA OR 119
21	F03010721	ANEL. OR 247,24X3,53 NBR				
22	F01050104	VIT.M10X 1,5X 45 U5927 14.9 BR	GRUB--SCREW 10X45 5927 14.9	GOUJON 10X45 5927 14.9	STIFT 10X45 UNI 5927 14.9	TORNILLO SIN CABEZA 10X45 5927
23	F06220014	VOLANTINO 8 LOBI M12X40 SX	8-LOBE HANDWHEEL M12X40 LEFT	VOLANT 8 LOBES M12X40 GCH	HANDRAD 8 BUCKEL M12X40 LINKS	VOLANTE 8 LOBI M12X40 IZQ
24	G16230590	ASS.SUPP.LEVA REGOLAZIONE ZN				
25	F01410051	ROS.M8 8,4X 17X1,6 U6592 ZN	WASHER M8 8,4X17X1,6 U6592 ZN	RONDEL. M8 8,4X17X1,6 U6592 ZN	SCHEIBE M8 8,4X17X1,6 U6592 ZN	ARANDELA M8 8,4X17X1,6 U6592ZN
26	F01200244	DADO M 8X1,25 U5588 6.8 ZN	NUT M8	ECROU M8	MUTTER M8	DADO M8
27	G16230610	ASS.LEVA REGOLAZIONE ZN				
28	F01410076	ROS.M12 13X 24X2,5 U6592 ZN	PLANE WASHER D12 UNI 6592 ZN	RONDELLE D12 UNI 6592 ZN	SCHEIBE D12 UNI 6592 ZN	ARANDELA D12 UNI 6592 ZN
29	G16230360	DADO M12X1,75 SX AUTOB.	M12X1,75 LEFT SELF-LOCK NUT	ECROU M12X1,75 GCH AUTOBLOCANT	MUTTER M12X1,75 LINKS SELBSTSP	TUERCA M12X1,75 IZ. AUTO.
30	G16230570	SUPPORTO REGOLAZIONE ZN				
31	F03010257	ANEL. T.AS 20X 42X 7 D3760NBR				
32	G19005710	SCATOLA CAMBIO				
33	G19703421	DECAL.REGOLAZ.CAMBIO PLA				
34	G16930920	MONT.SCATOLA CAMBIO CONC.PLA				

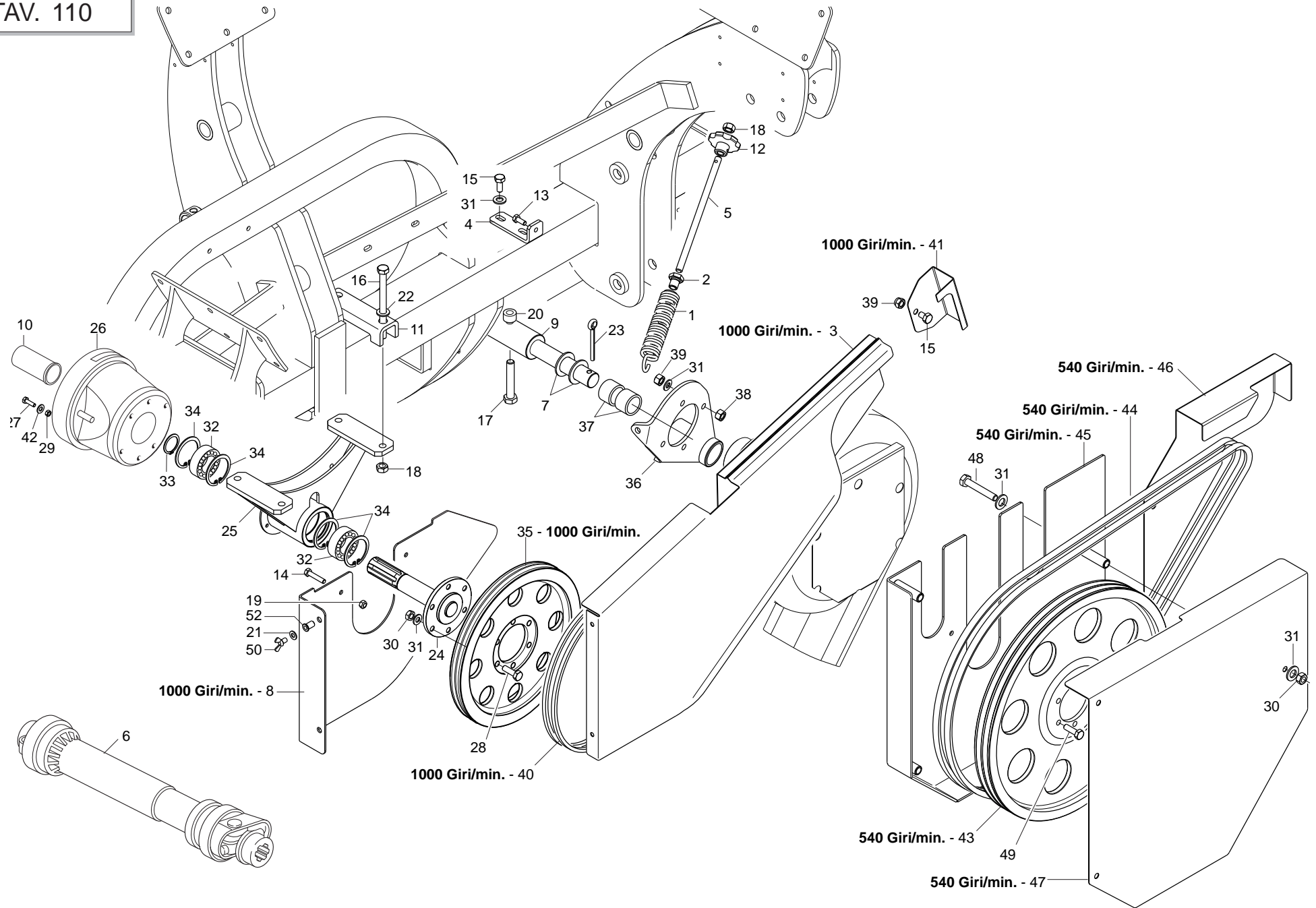

TRASMISSIONE SOFFIANTE

TAV. 110

Pos.	Cod.	Descrizione	Description	Description	Benennung	Descripcion
1	G13825210	MONT.MOLLA PRESS.USA >				
2	G15220120	VITE REGOLAZIONE ZN	REGULATION BOLT			
3	G17930390	CARTER	CASE	CARTER	GEHZUSE	CARTER
4	G17930460	PIATTO SUPPORTO CARTER	CASE SUPPORT	SUPPORT CARTER	HALTERUNG GEHZUSE	SOPORTE CARTER
5	G16730051	VITE REGOLAZIONE M12 ZN	ADJUSTMENT SCREW M12 ZN	VIS DE REGLAGE M12 ZN	EINSTELLSCHRAUBE M12 ZN	TORNILLO DE REGULACION M12 ZN
6	F08011716	CARD.B1 Z6-Z6 L900 R.LIB	UNIV.JOINT CE T100710 112 R12	CARD ROUE LIBRE T100710 112R12	KARDAN CE T100710 112 R12	CARDAN CE T100710 112 R12
7	G20970129	RONDELLA 48X3X30,5	WASHER 48X3X30-5	RONDELLE 48X3X30-5	UNTERLEGSSCHEIBE 48X3X30-5	ARANDELA 48X3X30-5
8	G17930450	LAMA SU SUPPORTO P.D.F.	PTO SUPPORT	SUPPORT PRISE DE FORCE	HALTERUNG KRAFTABTRIEB	SOPORTE TOMA DE FUERZA
9	GA7910480	ASSE PER FISSAGGIO VENTOLA ZN				
10	G66248227	CUFFIA PROTEZIONE P.D.P.	POWER TAKE-OFF PROTECTION HOUS	PROTECTEUR PRISE DE PUISSANCE	SCHUTZKASTEN KRAFTABTRIEB	ENVOLTURA PROTECCIN T. DE P. G
11	G13710560	SCONTRIO Q 100	FLANGE 'U' SP.8 100 2F16 118	BRIDE 'U' 100 SP.8 2F16 118	ANSCHLAG 'U' 100 SP.8 2F16 118	EL.DE EMPALME 'U' 100 2F16 118
12	F06220024	VOLANTINO 6 LOBI FEM.M12	6-LOBE HANDWHEEL M12	VOLANT 6 LOBES M12	HANDRAD 6 BUCKEL M12	VOLANTE 6 LOBULOS M12
13	F01020436	VITE M 8X1,25X 20 U5739 8.8 ZN	SCREW M8X1,25X20 U5739 8.8 ZN	VIS M8X1,25X20 U5739 8.8 ZN	SCHRA. M8X1,25X20 U5739 8.8 ZN	TORN. M8X1,25X20 U5739 8.8 ZN
14	F01020068	VITE M 8X1,25X40 U5737 8.8 ZN	SCREW M8X1,25X40 U5737 8.8 ZN	VIS M 8X1,25X40 U5737 8.8 ZN	SCHRA. M8X1,25X40 U5737 8.8 ZN	TORNIL.M8X1,25X40 U5737 8.8 ZN
15	F01020472	VITE M10X 1,5X25 U5739 8.8 ZN	BOLT 10X25 5739 8.G GALVANIZED	VIS 10X25 5739 8.G ZN	SCHRAUBE 10X25 5739 8.G ZN	TORNILLO 10X25 5739 8.G ZN
16	F01020179	VITE M12X1,75X150 5737 8.8 ZN	SCREW M12X1,75X150 5737 8.8 ZN	VIS M12X1,75X150 5737 8.8 ZN	SCHRA.M12X1,75X150 5737 8.8 ZN	TORN. M12X1,75X150 5737 8.8 ZN
17	F01020210	VITE M14X 2X 80 U5737 8.8 ZN	SCREW M14X 2X 80 U5737 8.8 ZN	VIS M14X 2X 80 U5737 8.8 ZG	SCHRA. M14X 2X80 U5737 8.8 ZN	TORN. M14X 2X 80 U5737 8.8 ZN
18	F01230059	DADO M12X1,75 D982 8 ZN	NUT M12X1,75 D982 8 ZN	ECROU M12X1,75 D982 8 ZN	MUTTER M12X1,75 D982 8 ZN	TUERCA M12X1,75 D982 8 ZN
19	F01220022	DADO M 8X1,25 D980 8 ZN	NUT M8X 1,25 D980 8 ZN	ECROU M8X 1,25 D980 8 ZN	MUTTER M8X 1,25 D980 8 ZN	TUERCA M8X 1,25 D980 8 ZN
20	G18803230	BOCCOLA 15 X22 X16 ZN				
21	F01410051	ROS.M8 8,4X 17X1,6 U6592 ZN	WASHER M8 8,4X17X1,6 U6592 ZN	RONDEL. M8 8,4X17X1,6 U6592 ZN	SCHEIBE M8 8,4X17X1,6 U6592 ZN	ARANDELA M8 8,4X17X1,6 U6592ZN
22	F01410076	ROS.M12 13X 24X2,5 U6592 ZN	PLANE WASHER D12 UNI 6592 ZN	RONDELLE D12 UNI 6592 ZN	SCHEIBE D12 UNI 6592 ZN	ARANDELA D12 UNI 6592 ZN
23	F02200260	COPIGLIA 8X 60 U1336 ZN	SPLIT PIN 8 X60 1336 GALVAN.	GOUPILLE 8 X60 1336 ZN	SPLINT 8 X60 1336 ZN	PASADOR 8 X60 1336 ZN
24	G16030011	PRESA DI FORZA	POWER TAKE-OFF	PRISE DE FORCE	ZAPFWELLE	TOMA DE FUERZA
25	G17930440	SUPPORTO CUSCINETTI P.D.F.	BEARING SUPPORT	SUPPORT PALIER	LAGERB.CHSE	SOPORTE COJINETE
26	F05150403	CUFFIA PROTEZ,CARDANO X GRUPPO	POWER TAKE-OFF PROTECTION HOUS	PROTECTEUR PRISE DE PUISSANCE	SCHUTZKASTEN KRAFTABTRIEB	ENVOLTURA PROTECCIN T. DE P. G
27	F01020404	VITE M 6X 1X20 U5739 8.8 ZN	BOLT 6X20 5739 8.G GALVANIZED	VIS 6X20 5739 8.G ZN	SCHRAUBE 6X20 5739 8.G ZN	TORNILLO 6X20 5739 8.G ZN
28	F01020479	VITE M10X 1,5X35 U5739 8.8 ZN	SCREW M10X1,5X35 U5739 8.8 ZN	VIS M10X1,5X35 U5739 8.8 ZN	SCHR. M10X1,5X35 U5739 8.8 ZN	TORN. M10X1,5X35 U5739 8.8 ZN
29	F01220011	DADO M 6X 1 D980 8 ZN	NUT M6X1 D980 8 ZN	ECROU M6X1 D980 8 ZN	MUTTER M6X1 D980 8 ZN	TUERCA M6X1 D980 8 ZN
30	F01220033	DADO M10X 1,5 D980 8 ZN	NUT M10X 1,5 D980 8 ZN	ECROU M10X 1,5 D980 8 ZN	MUTTER M10X 1,5 D980 8 ZN	TUERCA M10X 1,5 D980 8 ZN
31	F01410064	ROS.M10 10,5X 20X 2 U6592 ZN	WASHER M10 10,5X20X2 U6592 ZN	RONDELL.M10 10,5X20X2 U6592 ZN	SCHEIBE M10 10,5X20X2 U6592 ZN	ARAND. M10 10,5X20X2 U6592 ZN
32	F04010345	CUSC.D35 D62 B20 63007 2RS1>	BEARING 63007 2RS1	PALIER 63007 2RS1	LAGER 63007 2RS1	COJINETE 63007 2RS1
33	F02050146	ANELLO E. DE 35X 1,5 U7435 C70	ELASTIC RING DE 35X 1,5 U7435	BAGUE ELASTIQUE DE 35X 1,5	RING DE 35X 1,5 U7435 C70	ANILLO DE 35X 1,5 U7435 C70
34	F02050392	ANELLO E. DI 62X 2 U7437 C70	SEEGER RING E. 62X 2 U7437 C70	SEEGER E. 62X 2 U7437 C70	SEEGERING E. 62X 2 U7437 C70	ANILLO E. 62 X 2 U7437 C70
35	F06030091	PULEGGIA DE 328				
36	G17931320	SUPPORTO VENTOLE	FAN SUPPORT	SUPPORT ROTOR	HALTERUNG LAUFRAD	SOPORTE VENTILADOR
37	G16730170	BOCCOLA 30X40X30	BUSHING 30X40X30	BOITE 30X40X30	BUCHSE 30X40X30	CASQUILLO 30X40X30
38	F01200270	DADO M10X 1,5 U5588 6.8 ZN	NUT M10X 1,5 U5588 6.8 ZN	ECROU M10X 1,5 U5588 6.8 ZN	MUTTER M10X 1,5 U5588 6.8 ZN	TUERCA M10X 1,5 U5588 6.8 ZN
39	F01230048	DADO M10X 1,5 D982 8 ZN	NUT AUTOBLOC. M10 ZB	ECROU AUTOBLOC. M10 ZB	SCHEIBE AUTOBLOC. M10 ZB	TUERCA AUTOBLOC M10 ZB
40	F06010217	CINGHIA A 67	BELT- A 67	COURROIE A 67	RIEMEN A 67	CORREA A 67
41	G17931480	LAMA CARTER PER PULEGG.VENTOLA				
42	F01410037	ROS.M6 6,4X12,5X1,6 U6592 ZN	PLANE WASHER D.6	RONDELLE D.6	SCHEIBE D.6	ARANDELA D.6
43	G16033510	PULEGGIA D.479	DRIVEN PULLEY D.479	POULIE ENTRAINÉE D. 479	GETRIEBENE SCHEIBE D.479	POLEA CONDUCTIDA D.479
44	F06010222	CINGHIA A 81	BELT- A 81	COURROIE A 81	RIEMEN A 81	CORREA A 81
45	G17931440	CARTER PROT.ESTERNA 540G.				
46	G17931470	LAMA CARTER PULEGGIA				
47	G17931460	LAMA CARTER INTERNO				
48	F01020130	VITE M10X 1,5X90 U5737 8.8 ZN	BOLT M 10X90	VIS M 10X90	SCHRAUBE M 10X90	TORNILLO M 10X90
49	F01020476	VITE M10X 1,5X30 U5739 8.8 ZN	SCREW M10X1,5 X 30 5739 8.8 ZN	VIS M10X1,5 X 30 5739 8.8 ZN	SCHRA. M10X1,5X 30 5739 8.8 ZN	TORN. M10X1,5 X 30 5739 8.8 ZN
50	F01090216	VITE M 8X1,25X20 U5449 5.8 ZN	BOLT 8X20 UNI 5449 5.8 GALVANI	VIS 8X20 UNI 5449 5.8 ZN	SCHRAUBE 8X20 UNI 5449 5.8 ZN	TORNILLO 8X20 UNI 5449 5.8 ZN

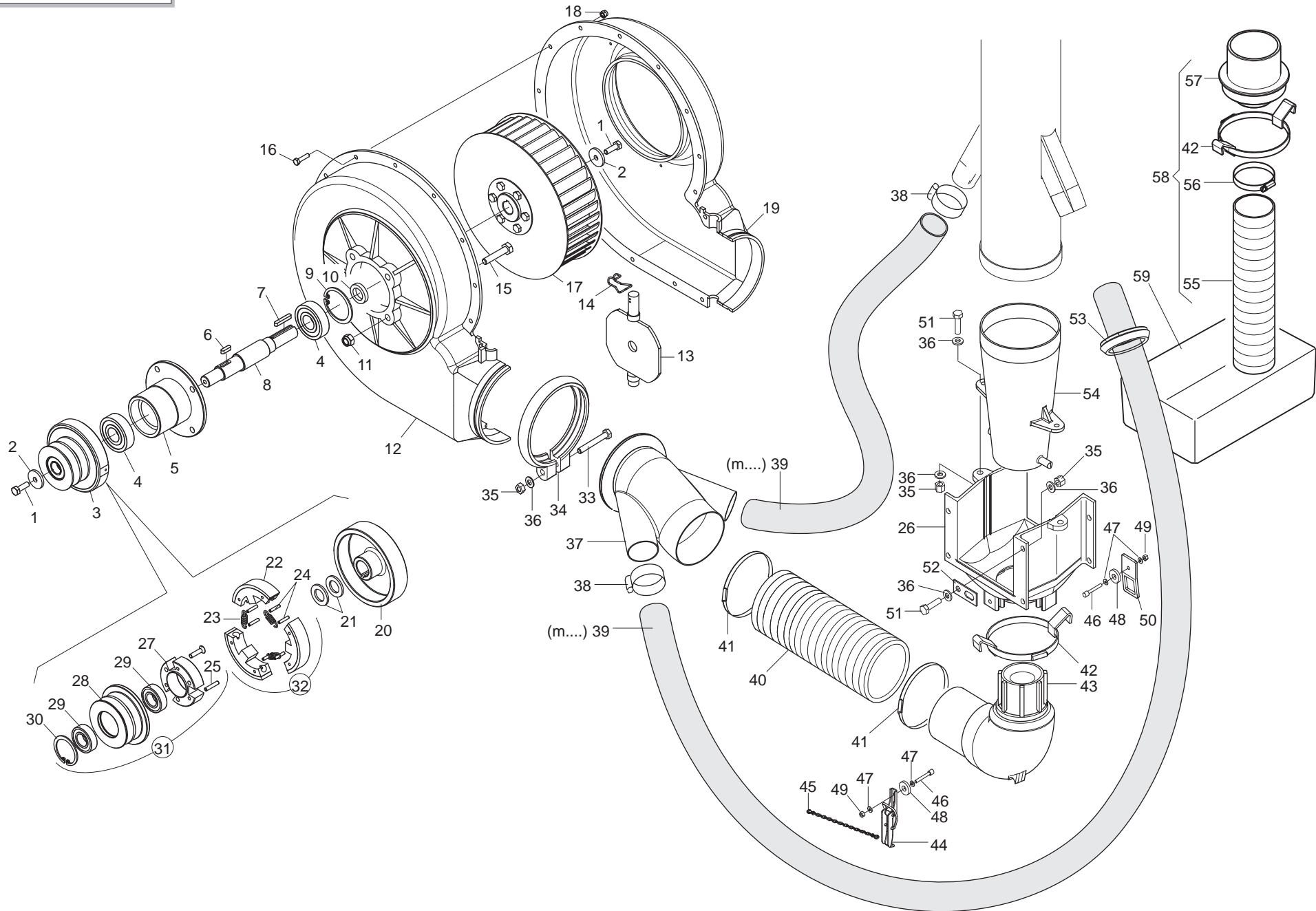

SOFFIANTE

TAV. 120

Pos.	Cod.	Descrizione	Description	Description	Benennung	Descripcion
1	F01020440	VITE M 8X1,25X25 U5739 8.8 ZN	BOLT M8 X25 5739 8.8 ZN	VIS M8 X25 5739 8.8 ZN	SCHRAUBE M8 X25 5739 8.8 ZN	TORNILLO M8 X25 5739 8.8 ZN
2	G20970032	RONDELLA 32X4X8,5	WASHER 32X4X8-5	RONDELLE 32X4X8-5	UNTERLEGSSCHEIBE 32X4X8-5	ARANDELA 32X4X8-5
3	G16050490	FRIZIONE SOFFIANTE COMPL	CLUTCH SLIPPING	EMBRAYAGE COULISS.	KUPPLUNG SICHERHEITS	ACOPLAMIENTO DESLIZANTE
4	F04010207	CUSC.D20 D52 B15 6304 Z	BEARING d20 D52 B15 6304 Z	PALIER d20 D52 B15 6304 Z	LAGER d20 D52 B15 6304 Z	COJINETE d20 D52 B15 6304 Z
5	G68005120	MOZZO ALBERO TRASMISSIONE	HUB	MOYEU	NABE	CUBO
6	F02150036	LINGUETTA 6X 6X 20 U6604A	TAB 06X6X20 UNI6604	LANGUETTE 06X6X20 UNI6604	FEDERKEIL 06X6X20 UNI6604	LENGSeta 06X6X20 UNI6604
7	G55140006	LINGUETTA 06X6X36 UNI6604	TAB 06X6X36 UNI6604	LANGUETTE 06X6X36 UNI6604	FEDERKEIL 06X6X36 UNI6604	LENGUETA 06X6X36 UNI6604
8	F06100691	ALBERO GIRANTE R.L.PULEG.80				
9	F02050392	ANELLO E. DI 62X 2 U7437 C70	SEEGER RING E. 62X 2 U7437 C70	SEEGER E. 62X 2 U7437 C70	SEEGERING E. 62X 2 U7437 C70	ANILLO E. 62 X 2 U7437 C70
10	G68005125	ANELLO 22X34X6	RING 22X34X6	BAGUE 22X34X6	RING 22X34X6	ANILLO 22X34X6
11	F01230048	DADO M10X 1,5 D982 8 ZN	NUT AUTOBLOC. M10 ZB	ECROU AUTOBLOC. M10 ZB	SCHEIBE AUTOBLOC. M10 ZB	TUERCA AUTOBLOC M10 ZB
12	G68005098	GUSCIO DX SOFFIANTE	RIGHT BLOWER SHELL	COQUILLE DROITE TURBINE	RE SCHALE GEBLÄSE	CASCO DER. TURBINA
13	G68005121	DEFLETTORE	DEFLECTOR	DEFLECTEUR	ABLENKER	DEFLECTOR
14	F02400016	MOLLA DI SICUREZZA	SPRING FOR SECURITY		FEDER SIG.	
15	F01020114	VITE M10X 1,5X50 U5737 8.8 ZN	SCREW M10X 1,5X50 U5737 8.8 ZN	VIS M10X 1,5X50 U5737 8.8 ZN	SCHRA.M10X 1,5X50 U5737 8.8 ZN	TORN. M10X 1,5X50 U5737 8.8 ZN
16	F01020406	VITE M 6X 1X 25 U5739 8.8 ZN	BOLT M6X25	VIS M6X25	SCHRAUBE M 6X25	TORNILLO M 6X25
17	G68005081	GIRANTE	IMPELLER	ROUE	LAUFRAD	RODETE
18	F01230022	DADO M 6X 1 D982 8 ZN	NORM.SELF-LOCKING NUT 6 GALVAN	ECROU AUTOB.NOR.6 ZN	SELBSTSP. MUTTER NOR.6 ZN	TUERCA AUTOB. NOR. 6 ZN
19	G68005099	GUSCIO SX SOFFIANTE	LEFT BLOWER SHELL	COQUILLE GAUCHE TURBINE	LI SCHALE GEBLÄSE	CASCO IZQ. TURBINA
20	G16050550	CAMPANA	BELL	CLOCKE	GLOCKE	CAMPANA
21	G16050560	DISTANZIATORE	SPACER	ENTRETOISE	DISTANZSTUCK	DISTANCIADOR
22	G16050510	MASSA	SKATE	PATIN	KUFE	PATIN
23	G18904390	MOLLA	SPRING	RESSORT	FEDER	MUELLE
24	F02100061	SPINA E.P. 4X 20 U6873 C70 BR	SPINA E.P. 4X20	SPLIT PIN 4X20	GOUPIILLE 4X20	CLAVIJA ELASTICA 4X20
25	F02100313	SPINA EL.5 X26 DIN 1481	PIN EL. 5 X26 DIN 1481	GOUPIILLE EL.5 X26 DIN 1481	SPANNSTIFT 5 X26 DIN 1481	CLAVIJA EL.5 X26 DIN 1481
26	G68005034	CORPO	CASING	CORPS	KTRPER	CUERPO
27	G16050540	MOZZO PORTAMASSE	HUB	MOYEU	NABE	CUBO
28	G16050530	PULEGGIA	DRIVEN PULLEY	POULIE ENTRAINEE	GETRIEBENE SCHEIBE	POLEA CONDUCIDA
29	F04010131	CUSC.D20 D42 B12 6004-2RSX EX>	BEARING 6004 2RS EX. SKF	ROULEMENT 6004	LAGER 6004	COJINETE 6004
30	F02050359	ANELLO E. DI 42X1,75 U7437 C70				
31	G16050520	PULEGGIA COMPL	DRIVEN PULLEY COMPL	POULIE ENTRAINEE COMPL	GETRIEBENE SCHEIBE KOMPL	POLEA CONDUCIDA COMPL
32	G16050500	MASSE	SKATES	PATINS	KUFE	PATINES
33	F01020083	VITE M 8X1,25X70 U5737 8.8 ZN	BOLT M8X70	VIS M8X70	SCHRAUBE M 8X70	TORNILLO M 8X70
34	G15355240	FASCETTA STRINGITUBO	PIPE CLAMP	COLLIER DE SERRAGE	ROHRSCHELLE	ABRAZADERA PARA MANGUERA
35	F01230034	DADO M 8X1,25 D982 8	SELF LOCK.NUT M8X1,25 D982 8ZN	ECROU AUTOBL.M8X1,25 D982 8 ZN	SELBST.MUTT.M8X1,25 D982 8 ZN	TUERCA AUTO. M8X1,25 D982 8 ZN
36	F01410051	ROS.M8 8,4X 17X1,6 U6592 ZN	WASHER M8 8,4X17X1,6 U6592 ZN	RONDEL. M8 8,4X17X1,6 U6592 ZN	SCHEIBE M8 8,4X17X1,6 U6592 ZN	ARANDELA M8 8,4X17X1,6 U6592ZN
37	G19005350	TUBO USCITA VENTOLA	UNION	RACCORD	ANSCHLUSSSTUCK	UNIN
38	F02300021	FASCETTA STRING. 40/60 H.8	STRING FASTEN.STRAPAS 40/60 H.8	COLLIER DE SERRAGE 40/60 H.8	SCELLE 40/60 H.8	ABRAZADERA 40/60 H.8
39	F03100493	TUBO EOLO PU 50	EOLO PIPE 50	TUBE EOLO 50	ROHR EOLO 50	TUBO EOLO 50
40	F03100427	TUBO FLESSIBILE D.100	FLEXIBLE PIPE D.100	TUBE FLEXIBLE D.100	SCHLAUCH D.100	TUBO FLEXIBILE D.100
41	F02300025	FASCETTA STRING. 90/110 H.12	STRING FASTENING STRAPS 90/110	COLLIER DE SERRAGE 90/110	ROHRSCHELLE 90/110	ABRAZADERA APRET. 90/110
42	G16021020	GANCIO CHIUSURA A LEVA	LEVER-CLOSED HOOK	CROCHET FERMETURE A LEVIER	HEBELSCHLISSHAKEN	GANCHO CIERRE DE PALANCA
43	G68005079	CURVA 145X147,5	145X147,5 BEND	COUDE D'AIR 145X147,5	KNIESTCK 145X147,5	CURVA 145X147,5
44	G16021040	LEVA CHIUSURA	CLOSURE LEVER	LEVIER DE FERMETURE	ABSCHLUSSHEBEL	PALANCA DE CIERRE
45	G13812311	CATENELLA CON MOSCHETTONE	CHAIN WITH SPRING CATCH	CHAINETTE AVEC MOUSQUETON	KETTE MIT KARABINERHAKEN	CADENA CON GANCHO
46	F01040030	VITE M 4X 0,7X35 U5931 12.9 ZN	BOLT 4 X30 5931 8.G GALVANIZ.	VIS 4 X30 5931 8.G ZN	SCHRAUBE 4 X30 5931 8.G ZN	TORNILLO 4 X30 5931 8.G ZN
47	F01410011	ROS.M4 4,3X 9X0,8 U6592 ZN	PLANE WASHER 4,5X 9 6592	RONDELLE 4,5X 9 6592	SCHEIBE 4,5X 9 6592	ARANDELA 4,5X 9 6592
48	G20970104	RONDELLA 21X4X8,5	WASHER 21X4X8-5	RONDELLE 21X4X8-5	UNTERLEGSSCHEIBE 21X4X8-5	ARANDELA 21X4X8-5
49	F01230016	DADO M 4X 0,7 D982 8 ZN	NORM.SELF-LOCKING NUT 4 GALVAN	ECROU AUTOB.NOR.4 ZN	SELBSTSP. MUTTER NOR. 4 ZN	TUERCA AUTOB. NOR. 4 ZN
50	G16021010	ATTACCO GANCIO CHIUSURA A LEVA	LEVER-OPERATED HOOK COUPLING	FIXATION CROCHET FERM.A LEVIER	KUPPLUNG HEBELSCHLISSHAKEN	CONEX. GANCHO CIERRE PALANCA
51	F01020445	VIT.M 8X1,25X 30 U5739 8.8 ZN	BOLT M 8X30	VIS M 8X30	SCHRAUBE M 8X30	TORNILLO M 8X30
52	G16020910	SUPP.SENSORE ALBERO DISTRIB.ZN	GALVANIS. TRANSM. SHAFT SENSOR	SUPP. CAPTEUR ARBRE DISTRIBUTI	HALTERUNG SENSOR VERTEILERWELL	SOPORTE SENSOR ARBOL DE DISTRI
53	F03011139	GUARNIZIONE D.70	SEAL D.70	GARNITURE D.70	DICHTUNG D.70	JUNTA D.70
54	F17920220	CONO DISTRIBUTORE 40 USCITE	DIFFUSOR	DIFFUSEURS	DIFFUSOREN	DIFUSORES
55	F03100421	TUBO ASPIREX 60 COLORE GRIGIO	PIPE ASPIREX 60 - GREY	TUBE ASPIREX 60 COULEUR GRIS	ROHR ASPIREX 60 FARBE GRAU	TUBO ASPIREX 60 COLOR GRIS
56	F02300022	FASCETTA STRING. 50/70 H.9	FASTEN. STRAPS 50/70 H.9	COLLIER DE SERRAGE 50/70 H.9	SCELLE 50/70 H.9	ABRAZADERA 50/70 H.9
57	G19003460	IMBUTO PROVA DI SEMINA	SOWING TEST FUNNEL	GOULOTTE ESSAI DEBIT	TRICHTER ABDREHPROBE	EMBUDO PRUEBA DE SEMBRADO
58	G15326850	IMBUTO PROVA DI SEMINA COMPL.	GOULOTTE ESSAY DEBIT COMPL.	GOULOTTE ESSAI DEBIT COMPL.	TRICHTER ABDREHPROBE KOMPL.	EMBUDO PRUEBA DE SEMINADO COMP
59	F05150370	BACINELLA 45X38X19	TRAY 45X38X19	BAC ESSAIS DE DEBIT 45X38X19	WANNE 45X38X19	CUBETA 45X38X19

A - Mandata OLIO - In OIL flux
Portata MAX di olio = 35 litri/min. ad una pressione di 150 bar.

B - Ritorno OLIO - Out OIL flux

N.B.

Collegare il tubo di ritorno (B) direttamente a scarico tramite l'apposito innesto in assenza di pressione. Se il trattore non ne fosse provvisto, consultare la **Casa Costruttrice** dello stesso.

Non si deve assolutamente usare il distributore idraulico per il ritorno dell'olio.

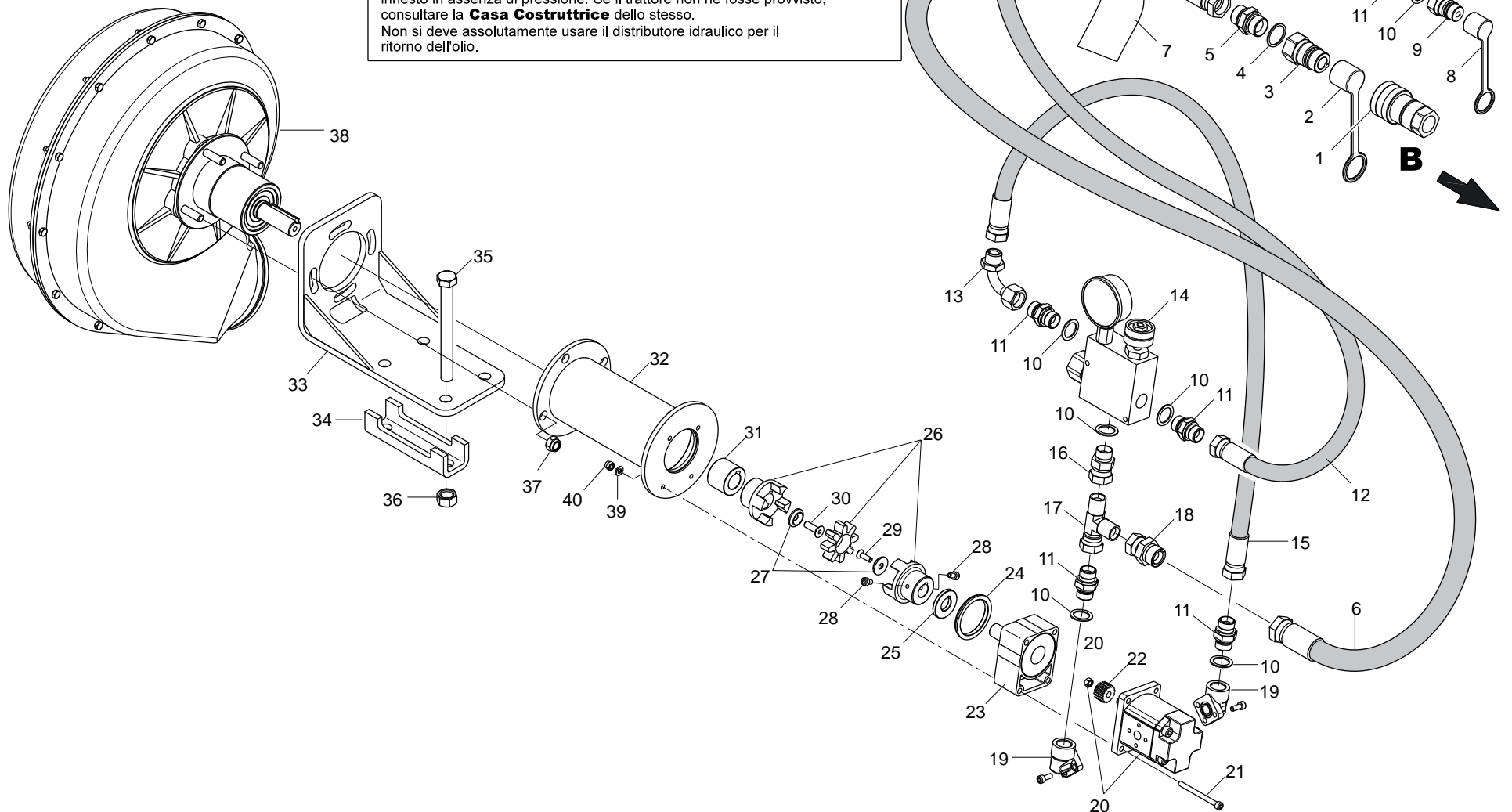

AZIONAMENTO OLEODINAMICO SOFFIANTE DIPENDENTE DA TRATTORE

TAV. 130

Pos.	Cod.	Descrizione	Description	Description	Benennung	Descripcion
1	F03150949	INNESTO RAP.FEMM.3/4 VALVOLA	QUICK-CONNECT 3/4 VALVE FEM.	PRISE A BILLE F/ELLE CONE 3/4	SCHNELLKUPPLUNG NUT 3/4	ACOPLA. RæP.HEMB.3/4 VæLVULA
2	F05150493	TAPPO INNESTO MASCHIO TF34	TF 34 MALE CONNECTION PLUG	CLAPET ACCOUPLEMENT MALE TF34	PFPROPFEN KUPPLUNG GEWINDEZAPFE	TAPA ACOPLAMIENTO MACHO TF34
3	F03150936	INNESTO RAP.MASCH.3/4 A VALV.	QUICK CONNECT MALE CONE 3/4 CO	PRISE A BILLE MALE CONE 3/4	SCHNELLKUPPLUNG GEWINDE KONISC	ACOPLAMIENTO RæPIDO MACHO CONO
4	F03151239	ROS. 27 X35X1,5 RAME -3/4"	3/4 COPPER WASHER	RONDELLE CUIVRE ϕ	UNTERLEGSCHIEBE KUPFER 3/4	ARANDELA COBRE 3/4
5	F03150299	NIPPLO MM CIL.CIL 3/4-3/4 ZN	NIPLES	NIPLES 3/4"GAS	NIPLES 3/4" GAS	NIPLE 3/4 - 3/4
6	G17930500	TUBO 3/4R2 F3/4-F3/4 2500	PIPE 3/4R2 F3/4-F3/4 2500	TUBE 3/4R2 F3/4-F3/4 2500	ROHR 3/4R2 F3/4-F3/4 2500	TUBO 3/4R2 F3/4-F3/4 2500
7	G19704520	DECALCOMANIA NON COLL.AL DISTR				
8	F05150325	CAPPUC.F X INN.M RAP.1/2 ROSSO	COVER CONNECT F 1/2 RED	COUVERCLE CONNEXION F 1/2 ROSE	DECKEL W 1/2 SCHNELLKUPP. ROT	PAC PROTECCION F 1/2 ROJO
9	F03150935	INNESTO RAP.MASCH.1/2 A VALV.	QUICK CONNECT MALE CONE 1/2	CONNEXION RAPIDE MALE CONE 1/2	SCHNELLKUPP.GEWINDE KONISC 1/2	ACOPLAMIENTO RAP.MACHO CONO 1/2
10	F03151237	ROS. 21 X27X1,5 RAME -1/2"	COPPER WASHER 21X27X1,5 1/2	RONDELLE CUIVRE 1/2 21X27X1,5	SCHEIBE KUPFER 1/2 21X27X1,5	ARANDELA COBRE 1/2 21X27X1,5
11	F03150255	NIPPLO MASCH.CIL.1/2-1/2 ZN	NIPLE 1/2"GAS	NIPLE 1/2"GAS	NIPLE 1/2"GAS	NIPLE 1/2"GAS
12	G15355300	TUBO 1/2 R2 F1/2-F1/2 L.2500	PIPE 1/2 R2 F1/2-F1/2 L.2500	TUBE 1/2 R2 F1/2-F1/2 L.2500	ROHR 1/2 R2 F1/2-F1/2 L.2500	TUBO 1/2 R2 F1/2-F1/2 L.2500
13	F03150858	CURVA 90°F.GIREV.1/2 - M.1/2	ELBOW 90[F. SWIVEL 1/2 -M.1/2	COUDE 90[F. TOURN.1/2 - M.1/2	KNIESTUCK 90[F.DREHB.1/2 - M.	CURVA 90 F.GIRAT.1/2 - M.1/2C
14	F03150541	VALVOLA PRIORIT.MANOM.P0550304	GUAGE PRIORITY VALVE	VALVE DE PRIORITE AVEC MANOME	PRIORITZTSVENTIL	VæLVULA PRIORITARIA MANMETRO V
15	G15355340	TUBO 1/2R2 500	PIPE 1/2R2 500	TUBE 1/2R2 500	ROHR 1/2R2 500	TUBO 1/2R2 500
16	F03150056	NIPPLO M-F 1/2 ZN	NIPPLE M-F 1/2 ZINC.	NIPPLE M-F 1/2 ZING.	NIPPEL M-F 1/2 VERZINK	NIPLE M-H 1/2 CINC.
17	F03151208	RACCORDO L 2M1/2 F1/2 ZN	UNION L 1/2	RACCORD L ®	ANSCHLUSSTsCK L 1/2	UNIN L 1/2 R
18	F03150089	NIPPLO M3/4-F1/2 GIREVOLE ZN	NIPPLE M3/4-F1/2 SWIVEL ZN	NIPPLE M3/4-F1/2 TOURNANT ZN	NIPPELZYL. M3/4-F1/2 DREHBAR	NIPLE M3/4-F1/2 GIRATORIO ZN
19	F03151203	RACCORDO A GOMITO 1/2'	1/2' ANGLED UNION	RACCORD A COUDE ®	WINKELANSCHLUSSTsCK 1/2'	CODO DE UNIN 1/2' R
20	F03151264	MOTORE INGR.DX 5,9 COMPL				
21	F01040070	VITE M 6X 1X70 U5931 8.8 ZN	BOLT M 6 X1 X 70	VIS M6X1 X 70	SCHRAUBE M6 X 1 X 70	TORNILLO M6 X1 X 70
22	F03151250	SEMIGIUNTO DENTATO Z-14 MOTORE	SEMI-COUPLING Z-14 ENGINE SIDE	SEMIJOINT Z-14 COTE MOTEUR	HALBKUPPLUNG Z-14 MOTORSEITE	SEMIJUNTA Z-14 LADO MOTOR
23	F06140023	TENDICINGHIA	BELT TIGHTENER	TENDEUR DE COURROIE	RIEMENSPANNER	SENSOR DE CORREA
24	G15355510	ANELLO	RING	BAGUE	RING	ANILLO
25	G15355480	DISTANZIALE D.18 ZN	SPACER D.18 GALVAN.	ENTRETOISE D.18 ZN	DISTANZSTsCK D.18 ZN	DISTANCIADOR D.18 ZN
26	G15355490	GIUNTO ELASTICO D.18-22	LOCK COUPLING D.18-22	JOINT DE BLOCAGE D.18-22	SPERRKUPPLUNG D.18-22	JUNTA DE BLOQUEO D.18-22
27	G15355500	RONDELLA AUTOCENTRANTE ZN	SELF-CENTERING WASHER ZN	RONDELLE AUTOCENTREE ZN	SELBSTZENTR.UNTERLEGSCH. ZN	ARANDELA AUTOCENTRADORA ZN
28	F01040058	VITE M 6X 1X10 U5931 8.8 ZN	BOLT 6 X10 5931 8.G GALVANIZ	VIS 6 X10 5931 8.G ZN	SCHRAUBE 6 X10 5931 8.G ZN	TORNILLO 6 X10 5931 8.G ZN
29	F01030038	VITE M 6X 1X20 U5933 10.9 ZD	BOLT M6X20	VIS M 6X20	SCHRAUBE M6X20	TORNILLO M6X20
30	F01030056	VITE M 8X1,25X25 U5933 10.9 ZD	BOLT 8X25 5933 10.9 GALVANIZED	VIS 8X25 5933 10.9 ZN	SCHRAUBE 8X25 5933 10.9 ZN	TORNILLO 8X25 5933 10.9 ZN
31	G15355470	DISTANZIALE D.22 ZN	SPACER D.22 GALVAN.	ENTRETOISE D.22 ZN	DISTANZSTsCK D.22 ZN	DISTANCIADOR D.22 ZN
32	G15355460	SUPPORTO TIROCINGHIA	BELT TIGHTENER SUPPORT	SUPPORT TIRE-COURROIE	RIEMENZUGHALTERUNG	SOPORTE SENSOR CORREA
33	G17930261	ASS.SUPPORTO SOFFIANTE				
34	G13710560	SCONTRIO Q 100	FLANGE 'U' SP.8 100 2F16 118	BRIDE 'U' 100 SP.8 2F16 118	ANSCHLAG 'U' 100 SP.8 2F16 118	EL.DE EMPALME 'U' 100 2F16 118
35	F01020276	VITE M16X 2X170 U5737 8.8 ZN	SCREW M16X2X170 U5737 8.8 ZN	VIS M16X2X170 U5737 8.8 ZN	SCHR. M16X2X170 U5737 8.8 ZN	TORNIL. M16X2X170 U5737 8.8 ZN
36	F01220266	DADO M16X 2 D980 8 ZN	NUT M16X 2 D980 8 ZN	ECROU M16X 2 D980 8 ZN	MUTTER M16X 2 D980 8 ZN	TUERCA M16X 2 D980 8 ZN
37	F01230048	DADO M10X 1,5 D982 8 ZN	NUT AUTOBLOC. M10 ZB	ECROU AUTOBLOC. M10 ZB	SCHEIBE AUTOBLOC. M10 ZB	TUERCA AUTOBLOC M10 ZB
38	G68005001	SOFFIANTE COMPLETA SENZA PUL.	BLOWER COMPLETE W/O PULLEY	SOUFFLANTE COMP.SANS POULIE K	OMPL. GEBLZSE O. RIEMENSCH. S	OPLADORA COMPLETA SIN PUL. S

TELAIO PORTA ELEMENTI ASSOLCATORI
TAV. 140

Pos.	Cod.	Descrizione	Description	Description	Benennung	Descripcion
1	G17917650	ASS.TELAIO CENTRALE				
2	G16016580	ANELLO SUPPORTO TUBI	SUPPORTING RING	BAGUE SUPPORT	HALTERUNGSRING	ANILLO SOPORTE
3	F01020510	VITE M12X1,75X30 U5739 8.8 ZN	BOLT M 12X30	VIS M 12X30	SCHRAUBE M 12X30	TORNILLO M 12X30
4	F20120349	PUNTALE Q.50 ALETT.POLIT.NERO				
5	F01020231	VITE M14X 2X190 U5737 8.8 BR	BOLT M 14 X190 5737 8.G	VIS M 14 X190 5737 8.G	SCHRAUBE M 14 X190 5737 8.G	TORNILLO M 14 X190 5737 8.G
6	F01230073	DADO M14X 2 D982 8 ZN	SELF LOCK. NUT M14X2 D982 8 ZN	ECROU AUTOBL. M14X2 D982 8 ZN	SELBSTSP.MUTT. M14X2 D982 8 ZN	TUERCA AUTOBL. M14X2 D982 8 ZN
7	F20110715	CAV.Q.M10X 1,5X 30 61X 80 ZN				
8	F01220033	DADO M10X 1,5 D980 8 ZN	NUT M10X 1,5 D980 8 ZN	ECROU M10X 1,5 D980 8 ZN	MUTTER M10X 1,5 D980 8 ZN	TUERCA M10X 1,5 D980 8 ZN
9	G17916000	LAMA SUPPORTO TUBI	PIPE SUPPORT	SUPPORT TUBES	ROHRHALTERUNG	SOPORTE TUBOS
10	F01220048	DADO M12X1,75 D980 8 ZN	NUT M12X1,75 D980 8 ZN	ECROU M12X1,75 D980 8 ZN	SCHEIBE M12X1,75 D980 8 ZN	TUERCA M12X1,75 D980 8 ZN
11	F01410076	ROS.M12 13X 24X2,5 U6592 ZN	PLANE WASHER D12 UNI 6592 ZN	RONDELLE D12 UNI 6592 ZN	SCHEIBE D12 UNI 6592 ZN	ARANDELA D12 UNI 6592 ZN
12	GA7911070	ASS.TEL.LATERALE SX				
13	GA7911060	ASS.TEL.LATERALE DX				
14	GA7911140	ASS.TEL.LATERALE SX 500				
15	GA7911150	ASS.TEL.LATERALE DX 500				
16	G17919290	ASS.TELAIO LATERALE SX 400				
17	G17919280	ASS.TELAIO LATERALE DX 400				
18	GA7910660	ASS.TEL.LATERALE SX 450				
19	GA7910650	ASS.TEL.LATERALE DX 450				
20	F01020212	VITE M14X 2X 90 U5737 8.8 ZN	SCREW M14X 2X 90 U5737 8.8 ZN	VIS M14X 2X 90 U5737 8.8 ZN	SCHARUBE M14X2X90 U5737 8.8 ZN	TORNILLO M14X2X90 U5737 8.8 ZN
21	F01220255	DADO M14X 2 D980 8 ZN	NUT- TRISTOP M14X2 D980 8 ZN	ECROU TRISTOP M14X2 D980 8 ZN	MUTTER TRISTOP M14X2 D980 8 ZN	TUERCA TRISTOP M14X2 D980 8 ZN
22	F01020041	VITE M 6X 1X 45 U5737 8.8 ZN	BOLT 6 X45 5737 8.G GALVANIZED	VIS 6 X45 5737 8.G ZN	SCHRAUBE 6 X45 5737 8.G ZN	TORNILLO 6 X45 5737 8.G ZN
23	F01220011	DADO M 6X 1 D980 8 ZN	NUT M6X1 D980 8 ZN	ECROU M6X1 D980 8 ZN	MUTTER M6X1 D980 8 ZN	TUERCA M6X1 D980 8 ZN
24	F02200584	SPINA SICUR. D. 12X70 ZN	PIN D12 L70 ZN	FICHE D12 L70 ZN	STIFT D12 L70 ZN	CLAVIJA D12 L70 ZN
25	G10710032	PUNTELLO	PROP	ETRESILLON	STsTZE	PUNTAL
26	G17918090	ASS.SUPPORTO PUNTELLO				
27	G13812311	CATENELLA CON MOSCHETTONE	CHAIN WITH SPRING CATCH	CHAINETTE AVEC MOUSQUETON	KETTE MIT KARABINERHAKEN	CADENA CON GANCHO

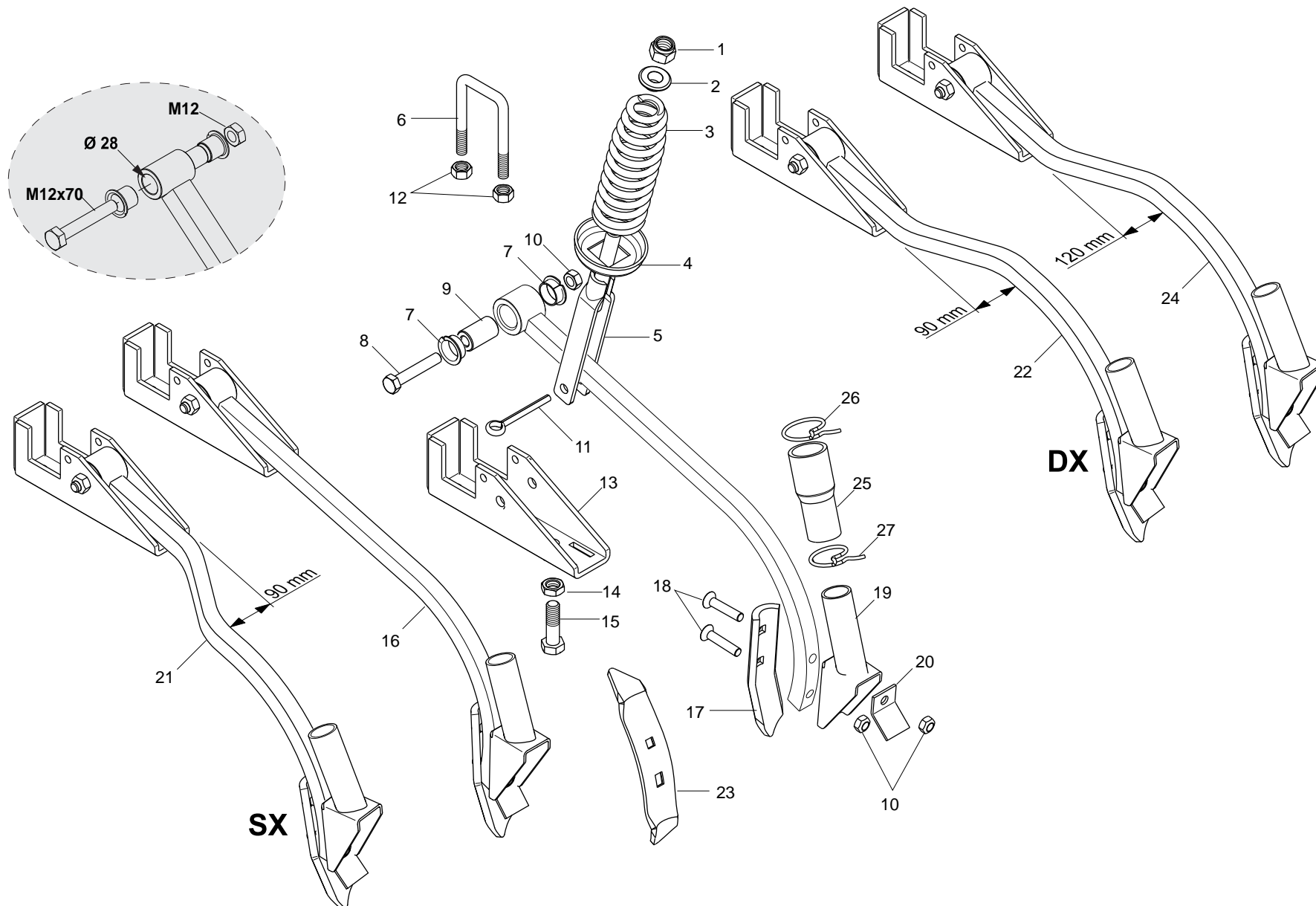

ELEMENTI OPERATORI A MOLLA

TAV. 150

Pos.	Cod.	Descrizione	Description	Description	Benennung	Descripcion
1	F01230084	DADO M16X1,5 D982 6 ZN	SELF LOCKING NUT M16X1,5	ECROU AUTOBL. M16X1,5	SELBSTSPERR.MUTTER M16X1,5	DADO AUTOBL. M16X1,5
2	G17940931	BOCCOLA GUIDA MOLLA ZN				
3	G16940510	MOLLA COMPRESSIONE ELEMENTO	ELEMENT COMPRESSION SPRING	RESSORT COMPRESSION +L+MENT	DRUCKFEDER ELEMENT	MUELLE COMPRESIEN ELEMENTO
4	G16940540	RONDELLA FERMO MOLLA COMPRESS.	COMPRESS. SPRING LOCK WASHER	RONDELLE ARR-T RESSORT COMPRES	SPERRSCHEIBE DRUCKFEDER	ARANDELA DE TOPE MUELLE COMPRESIEN
5	G16940560	GUIDA MOLLA	SPRING GUIDE	GUIDAGE RESSORT	FEDERF_HRUNG	GU-A MUELLE
6	F20110740	CAV.Q.M12X1,75X 35 63X 98 ZN	U BOLT M12X63 -95 ZN	CAVALIER M12X63 -95 ZN	VERBINDUNG M12X63 -95 ZN	PERNO EN U M12X63 -95 ZN
7	F04150034	CUSCINETTO FLANGIATO 25X28X16				
8	F01020164	VITE M12X1,75X70 U5737 8.8 ZN	SCREW M12X1,75X70 U5737 8.8 ZN	VIS M12X1,75X70 U5737 8.8 ZN	SCHR. M12X1,75X70 U5737 8.8 ZN	TORN. M12X1,75X70 U5737 8.8 ZN
9	G18803270	BOCCOLA 12 X25 X42				
10	F01220048	DADO M12X1,75 D980 8 ZN	NUT M12X1,75 D980 8 ZN	ECROU M12X1,75 D980 8 ZN	SCHEIBE M12X1,75 D980 8 ZN	TUERCA M12X1,75 D980 8 ZN
11	F02200272	COPIGLIA 10X 60 U1336 ZN	SPLIT PIN 10 X60 1336 GALVAN.	GOUPILLE 10 X60 1336 ZN	SPLINT 10 X60 1336 ZN	PASADOR 10 X60 1336 ZN
12	F01220048	DADO M12X1,75 D980 8 ZN	NUT M12X1,75 D980 8 ZN	ECROU M12X1,75 D980 8 ZN	SCHEIBE M12X1,75 D980 8 ZN	TUERCA M12X1,75 D980 8 ZN
13	G16940991	ASS.SUPPORTO MOLLA				
14	F01200432	DADO M14X 1,5 U5589 6S ZN	NUT M14X1.5	ECROU M14X1.5	MUTTER M14X1.5	DADO M14X1.5
15	F01020547	VITE M14X 2X50 U5739 8.8 ZN	BOLT M14X2X50	VIS M14X2X50	SCHRAUBE M14X2X50	TORNILLO M14X2X50
16	G17940081	MONT.MOLLA				
17	G16940530	PUNTALE DRITTO	STRAIGHT TIP	EMBOUT DROIT	GERADE ST_TZE	PUNTAL RECTO
18	F01060114	BUL.M10X 1,5X 50 U6104 4.6 BR	BOLT M 10X50 6104 4.6	BOULON M 10X50 6104 4.6	SCHRAUBE M 10X50 6104 4.6	PERNO M 10X50 6104 4.6
19	G17940010	SCARPETTA MOLLA	SLIDE SPRING	SABOT RESSORT	FEDERSCHUH	GUIA DE APOLLO MUELLE
20	G17940040	LAMA DISCESA SEME	SEED DELIVERY BLADE	LAME DESCENTE GRAINE	SAMENFALLMESSER	CUCHILLA BAJADA SEMILLAS
21	G17940601	MONT.MOLLA SX				
22	G17940581	MONT.MOLLADX				
23	G16941020	VOMERE MOLLA ELEMENTO	PLOWSHARE SPRING ELEMENT	SOC RESSORT ELEMENT	PFLUGSCHAR FEDER ELEMENT	REJA MUELLE ELEMENTO
24	G17940621	MONT.MOLLA 120 DX				
25	F05150361	RIDUZIONE	REDUCTION	REDUCTION	UNTERSETZUNG	REDUCCIN R
26	G65336001	MOLLA SPEC.ZN STRING.CONC. SP	SPEC SPRING ZN MAN. PIPE CLAMP	RESSORT SPEC. ZN SERRE-TUBE LO	SPEZIALFEDER ZN DsNGERSCHELLE.	MUELLE ESPEC. ZN APLASTA ABONO
27	G65336025	MOLLA SPEC.ZN STRINGIT.ASP.SP	SPEC SPRING ZN FAN . PIPE CLAMP	RESSORT SPEC. ZN SERRE-TUBE AS	SPEZIALFEDER ZN RORRSCHELLE AB	MUELLE ESPEC. ZN APRIETA TUBOS

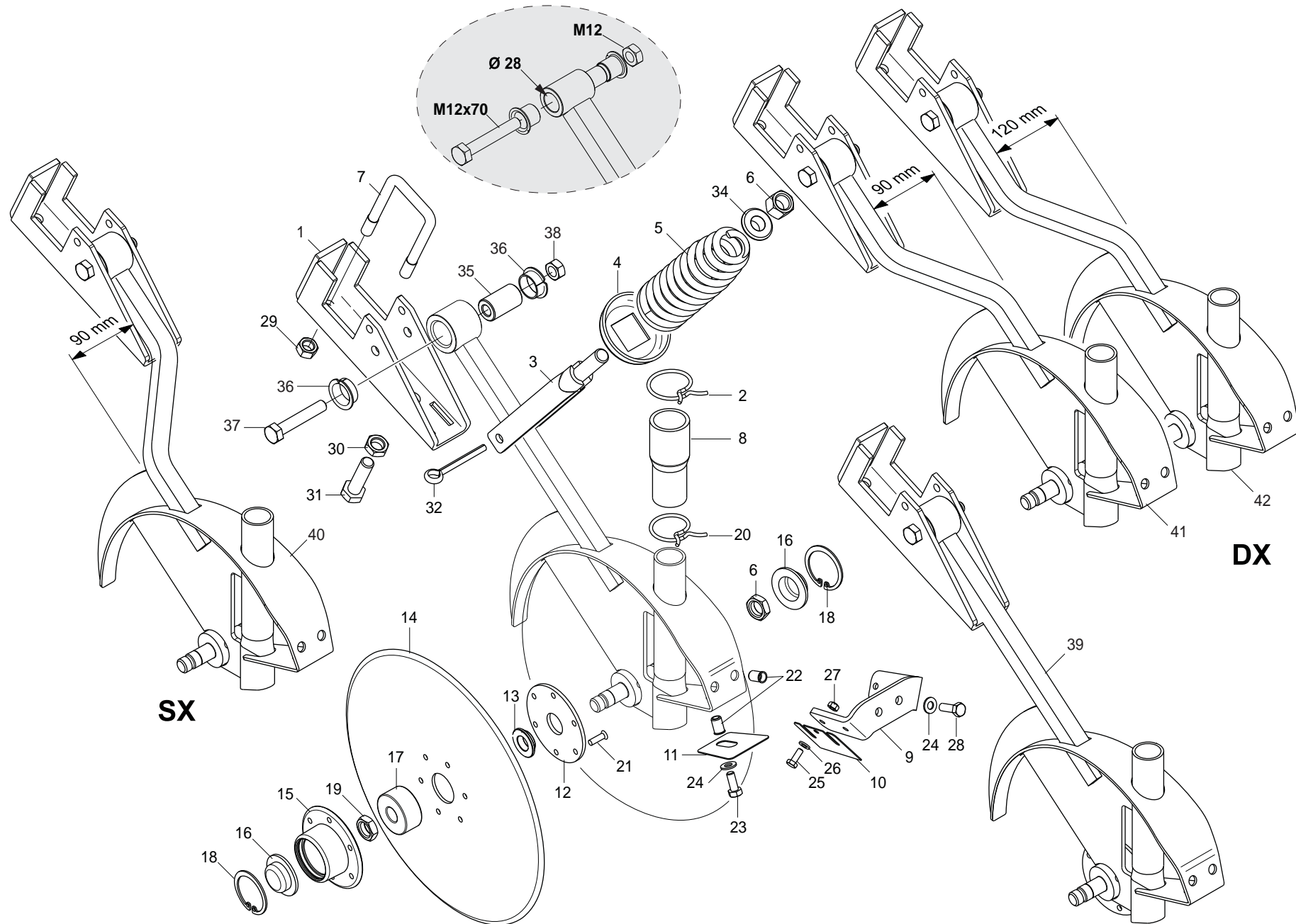

ELEMENTI OPERATORI A DOPPIO DISCO

TAV. 160

Pos.	Cod.	Descrizione	Description	Description	Benennung	Descripcion
1	G16940991	ASS.SUPPORTO MOLLA				
2	G65336001	MOLLA SPEC.ZN STRING.CONC. SP	SPEC SPRING ZN MAN. PIPE CLAMP	RESSORT SPEC. ZN SERRE-TUBE LO	SPEZIALFEDER ZN DsNGERSCHELLE.	MUELLE ESPEC. ZN APLASTA ABONO
3	G16940560	GUIDA MOLLA	SPRING GUIDE	GUIDAGE RESSORT	FEDERF_HRUNG	GU-A MUELLE
4	G16940540	RONDELLA FERMO MOLLA COMPRESS.	COMPRESS. SPRING LOCK WASHER	RONDELLE ARR-T RESSORT COMPRES	SPERRSCHEIBE DRUCKFEDER	ARANDELA DE TOPE MUELLE COMPRE
5	G16940510	MOLLA COMPRESSIOE ELEMENTO	ELEMENT COMPRESSION SPRING	RESSORT COMPRESSION +L+MENT	DRUCKFEDER ELEMENT	MUELLE COMPRESIÉN ELEMENTO
6	F01200442	DADO M16X 1,5 U5589 6.8 ZN	NUT 16X1-5 UNI 5589 6.8 GALVAN	ECROU 16X1-5 UNI 5589 6.8 ZN	MUTTER 16X1-5 UNI 5589 6.8 ZN	TUERCA 16X1-5 UNI 5589 6.8 ZN
7	F20110740	CAV.Q.M12X1,75X 35 63X 98 ZN	U BOLT M12X63 -95 ZN	CAVALIER M12X63 -95 ZN	VERBINDUNG M12X63 -95 ZN	PERNO EN U M12X63 -95 ZN
8	F05150361	RIDUZIONE	REDUCTION	REDUCTION	UNTERSETZUNG	REDUCCIN R
9	G17940850	LAMA SUPPORTO RASCHIATERRA	SOIL SCRAPER SUPPORT	SUPPORT RACLEUR	HALTERUNG ERDSCHABER	SOPORTE RASCADOR TIERRA
10	G17940750	RASCHIATERRA DISCO	DISK SOIL-SCRAPER	RACLEUR DISQUE	ERDSCHABER SCHEIBE	RASCADOR DISCO
11	G17940770	RASCHIATERRA CENTRALE DISCO	CENTRAL SOIL SCRAPER	DECROTTOIR CENTRAL	ZENTRALER ABSTREIFER	RASCADOR DE TIERRA CENTRAL
12	G22310057	FLANGIA INTERNA DISCO DP	INNER DISK FLANGE DP	BRIDE INT. DISQUE DP	INNENFLANSCH SCHEIBE DP	BRIDA INTERIOR DISCO DP
13	G13825081	BOCCOLA PARAPOLVERE DISCO	DISC DUST SEAL BUSH	DOUILLE PARE-POUSSI+RE DISQUE	BUCHSE STAUBABDECKUNG SCHEIBE	MANGUITO GUARDAPOLVO DISCO
14	G17940910	DISCO ASSOLCATORE D.320	FURROW OPENER DISK D.320	DISQUE OUVR DD D.320	SCHIEBE SZSCHAR D.320	DISCOS SURCADORES D.320
15	G15223651	SUPPORTO CUSCINETTO DISCO	DISK BEARING SUPPORT	SUPPORT PALIER DISQUE	SCHEIBENLAGERBsCHSE	SOPORTE COJINETE DISCO
16	G66248248	TAPPO IN PLASTICA	PLASTIC PLUG	BOUCHON EN PLASTIQUE	PLASTIKPFROPFEN	TAPN DE PLÆSTICO D
17	F04010084	CUSC.D17D47 B22,2 3303 LLU/DDU	BEARING 3303 2RS	PALIER 3303 2RS	LAGER 3303 2RS	COJINETE 3303 2RS
18	F02050370	ANELLO E. DI 47X1,75 U7437 C70	SEEGER RING 47X 1,75 U7437 C70	SEEGER E. 47X 1,75 U7437 C70	SEEGERING E. 47X1,75 U7437 C70	ANILLO E. 47X 1,75 U7437 C70
19	G15220540	DADO M16X1,5 SX	NUT M16X1-5 LEFT	ECROU M16X1-5 GCH	MUTTER M16X1-5 LI	TUERCA M16X1-5 IZQ
20	G65336025	MOLLA SPEC.ZN STRINGIT.ASP.SP	SPEC SPRING ZN FAN . PIPE CLAM	RESSORT SPEC. ZN SERRE-TUBE AS	SPEZIALFEDER ZN RORHSCHELLE AB	MUELLE ESPEC. ZN APRIETA TUBOS
21	F02250431	RIBATTINO TPS 5X19 U752	PACK RIVETS TPS 5 X 19 KG	PAQUET RIVETS TPS 5 X 19 KG	PACKUNG NIETEN TPS 5 X 19 KG	PAQU. DE REMACHES TPS 5 X 19
22	F02250682	INSERTO FIL.M 8X16 ZN T.RIDOTT	CYLINDRICAL NUT 8X16 ZG T.RIDO	ECROU CYLINDRIQUE 8X16 ZG T.RI	ZYLINDRISCHE MUTTER 8X16 ZG	TUERCA CILINDRICA 8X16 ZG T.RI
23	F01020436	VITE M 8X1,25X 20 U5739 8.8 ZN	SCREW M8X1,25X20 U5739 8.8 ZN	VIS M8X1,25X20 U5739 8.8 ZN	SCHRA. M8X1,25X20 U5739 8.8 ZN	TORN. M8X1,25X20 U5739 8.8 ZN
24	F01420048	ROS.M8 8,4X 24X 2 U6593 ZN	PLANE WASHER D.8	RONDELLE D.8	SCHEIBE D.8	ARANDELA D.8
25	F01020403	VITE M 6X 1X 16 U5739 8.8 ZN	SCREW M6X1X16 U5739 8.8 ZN	VIS M6X1X16 U5739 8.8 ZN	SCHRAUBE M6X1X16 U5739 8.8 ZN	TORNILLO M6X1X16 U5739 8.8 ZN
26	F01420036	ROS.M6 6,4X 18X 2 U6593 ZN	FLAT WASHER 6-6X 18X2 6593 ZN	ROND. PLATE 6-6X 18X2 6593 ZN	SCHEIBE 6-6X 18X2 6593 ZN	ARAND. PLANA 6-6X 18X2 6593 ZN
27	F01220011	DADO M 6X 1 D980 8 ZN	NUT M6X1 D980 8 ZN	ECROU M6X1 D980 8 ZN	MUTTER M6X1 D980 8 ZN	TUERCA M6X1 D980 8 ZN
28	F01020440	VITE M 8X1,25X25 U5739 8.8 ZN	BOLT M8 X25 5739 8.8 ZN	VIS M8 X25 5739 8.8 ZN	SCHRAUBE M8 X25 5739 8.8 ZN	TORNILLO M8 X25 5739 8.8 ZN
29	F01220048	DADO M12X1,75 D980 8 ZN	NUT M12X1,75 D980 8 ZN	ECROU M12X1,75 D980 8 ZN	SCHEIBE M12X1,75 D980 8 ZN	TUERCA M12X1,75 D980 8 ZN
30	F01200432	DADO M14X 1,5 U5589 6S ZN	NUT M14X1.5	ECROU M14X1.5	MUTTER M14X1.5	DADO M14X1.5
31	F01020547	VITE M14X 2X50 U5739 8.8 ZN	BOLT M14X2X50	VIS M14X2X50	SCHRAUBE M14X2X50	TORNILLO M14X2X50
32	F02200272	COPIGLIA 10X 60 U1336 ZN	SPLIT PIN 10 X60 1336 GALVAN.	GROUPILLE 10 X60 1336 ZN	SPLINT 10 X60 1336 ZN	PASADOR 10 X60 1336 ZN
33	F01230084	DADO M16X1,5 D982 6 ZN	SELF LOCKING NUT M16X1,5	ECROU AUTOBL. M16X1,5	SELBSTSPERR.MUTTER M16X1,5	DADO AUTOBL. M16X1,5
34	G17940931	BOCCOLA GUIDA MOLLA ZN				
35	G18803270	BOCCOLA 12 X25 X42				
36	F04150034	CUSCINETTO FLANGIATO 25X28X16				
37	F01020164	VITE M12X1,75X70 U5737 8.8 ZN	SCREW M12X1,75X70 U5737 8.8 ZN	VIS M12X1,75X70 U5737 8.8 ZN	SCHR. M12X1,75X70 U5737 8.8 ZN	TORN. M12X1,75X70 U5737 8.8 ZN
38	F01220048	DADO M12X1,75 D980 8 ZN	NUT M12X1,75 D980 8 ZN	ECROU M12X1,75 D980 8 ZN	SCHEIBE M12X1,75 D980 8 ZN	TUERCA M12X1,75 D980 8 ZN
39	G17940861	MONT.DISCHI DOPPI				
40	G17940871	MONT.DISCHI DOPPI 90 SX				
41	G17940881	MONT.DISCHI DOPPI 90 DX				
42	G17940891	MONT.DISCHI DOPPI 120 DX				

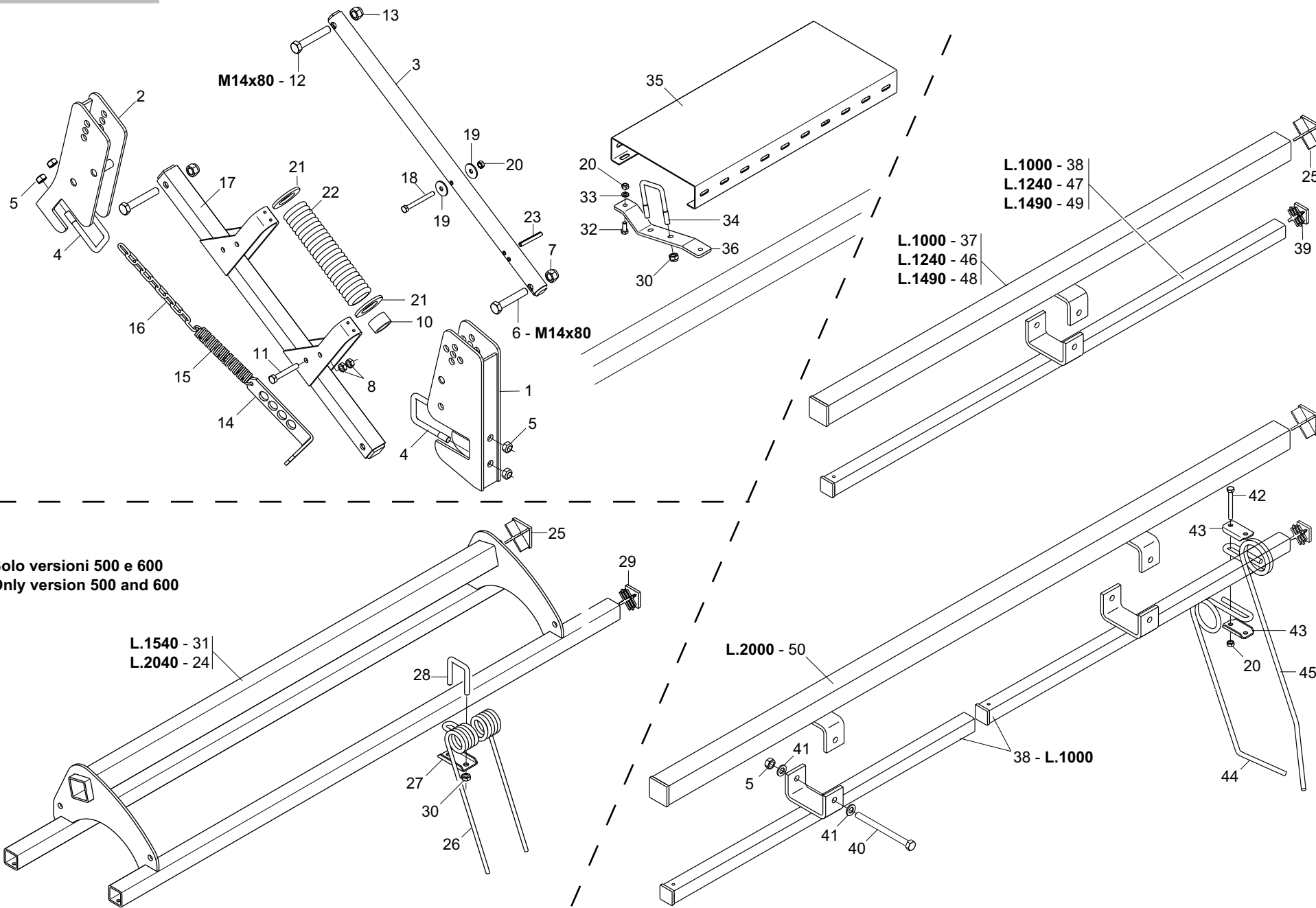

ERPICE COPRISEME

TAV. 170

Pos.	Cod.	Descrizione	Description	Description	Benennung	Descrpcion
1	G17917940	ASS.ATTACCO ERPICE COPRISEME				
2	G17917910	ASS.ATTACCO ERPICE COPRISEME				
3	G16041760	TUBO SUP.ERPICE	PIPE SUPPORT	TUBE SUPPORT	ALTERUNGSROHR	TUBO SOPORTE
4	F20110740	CAV.Q.M12X1,75X 35 63X 98 ZN	U BOLT M12X63 -95 ZN	CAVALIER M12X63 -95 ZN	VERBINDUNG M12X63 -95 ZN	PERNO EN U M12X63 -95 ZN
5	F01220048	DADO M12X1,75 D980 8 ZN	NUT M12X1,75 D980 8 ZN	ECROU M12X1,75 D980 8 ZN	SCHEIBE M12X1,75 D980 8 ZN	TUERCA M12X1,75 D980 8 ZN
6	F01020210	VITE M14X 2X 80 U5737 8.8 ZN	SCREW M14X 2X 80 U5737 8.8 ZN	VIS M14X 2X 80 U5737 8.8 ZG	SCHRA. M14X 2X80 U5737 8.8 ZN	TORN. M14X 2X 80 U5737 8.8 ZN
7	F01220255	DADO M14X 2 D980 8 ZN	NUT- TRISTOP M14X2 D980 8 ZN	ECROU TRISTOP M14X2 D980 8 ZN	MUTTER TRISTOP M14X2 D980 8 ZN	TUERCA TRISTOP M14X2 D980 8 ZN
8	F01200270	DADO M10X 1,5 U5588 6.8 ZN	NUT M10X 1,5 U5588 6.8 ZN	ECROU M10X 1,5 U5588 6.8 ZN	MUTTER M10X 1,5 U5588 6.8 ZN	TUERCA M10X 1,5 U5588 6.8 ZN
9	F01420118	ROS.M36 39X 66X 5 U6593 ZN	WASHER M36 39X66X5 U6593 ZN	RONDELLE M36 39X66X5 U6593 ZN	SCHEIBE M36 39X66X5 U6593 ZN	ARANDELA M36 39X66X5 U6593 ZN
10	G18802050	BOCCOLA 35,25X45X18				
11	F01020122	VITE 10X 1,5X 70 U5737 8.8 ZN	BOLT 10X 1,5X 70 U5737 8.8 ZB	VIS 10X 1,5X 70 U5737 8.8 ZB	SCHR.10X 1,5X 70 U5737 8.8 ZB	TORN.10X 1,5X 70 U5737 8.8 ZB
12	F01020212	VITE M14X 2X 90 U5737 8.8 ZN	SCREW M14X 2X 90 U5737 8.8 ZN	VIS M14X 2X 90 U5737 8.8 ZN	SCHARUBE M14X2X90 U5737 8.8 ZN	TORNILLO M14X2X90 U5737 8.8 ZN
13	F01200306	DADO M14X 2 U5588 6.8 ZN	NUT M14X2	ECROU M14X2	MUTTER M14X2	DADO M14X2
14	G17917990	LAMA DI REGOLAZIONE				
15	G18903540	MOLLA TRAZIONE SCARPETTE	PLANTER SHOE TRACTION SPRING	RESSORT TRACTION SABOTS	ZUGFEDER SZSCHAREN	MUELLE TRACCIN GUA APOYO AR
16	G16240510	CATENA GENOVESE L.235 ZN	GENOAN CHAIN D.5 L.235 GALVAN	CHAINE GENOISE D.5 L.235 ZN	KETTE GENOVESE D.5 L.235 ZN	CADENA GENOVESA D.5 L.235 ZN
17	G16243441	TUBO INFERIORE ERPICE				
18	F01020086	VITE M 8X1,25X80 U5737 8.8 ZN	BOLT M8X1X80	VIS M8X1X80	SCHRAUBE M8X1X80	TORNILLO M8X1X80
19	G20970032	RONDELLA 32X4X8,5	WASHER 32X4X8-5	RONDELLE 32X4X8-5	UNTERLEGSCHIEBE 32X4X8-5	ARANDELA 32X4X8-5
20	F01220022	DADO M 8X1,25 D980 8 ZN	NUT M8X 1,25 D980 8 ZN	ECROU M8X 1,25 D980 8 ZN	MUTTER M8X 1,25 D980 8 ZN	TUERCA M8X 1,25 D980 8 ZN
21	F01420118	ROS.M36 39X 66X 5 U6593 ZN	WASHER M36 39X66X5 U6593 ZN	RONDELLE M36 39X66X5 U6593 ZN	SCHEIBE M36 39X66X5 U6593 ZN	ARANDELA M36 39X66X5 U6593 ZN
22	G18903560	MOLLA COMPRESSIONE ERPICE	SPRING.	RESSORT COMPL.	DRUCKFEDER	MUELLE COMP.
23	F02100146	SPINA E.P. 8X 55 U6873 C70 BR	PIN EL. .8 X55 DIN 1481	FICHE EL.8 X55 DIN 1481	SPANNSTIFT 8 X55 DIN 1481	CLAVIJA EL.8 X55 DIN 1481
24	G17919410	ASS.BARRA SUPP.MOLLE				
25	F20120349	PUNTALE Q.50 ALETT.POLIT.NERO				
26	G18904190	MOLLA COPRISEME POST.	SEED COVERING SPRING	RESSORT RECOUVRE-GRAINES	SAATGUTZUSTREICHFEDER	MUELLE CUBRESEMILLAS
27	G16240780	PIASTRINA MOLLA COPRISEME	PLATE SEED COVER SPRING	PLAQUETTE RESSORT COUVRE-GRAIN	PLZTTCHEN SAMENABDECKFEDER	PLAQUETA MUELLE CUBRESEMILLAS
28	F20110705	CAV.Q.M10X 1,5X 30 51X 62 ZN	U-BOLT GALVAN	CAVALIER ZN	BsGELBOLZEN ZN	PERNO EN U ZN
29	F20120348	PUNTALE Q.40	TIP Q.40	MANCHON Q.40 PLASTIQUE	STTSSELSCHAFT Q.40	PUNTAL Q.40
30	F01220033	DADO M10X 1,5 D980 8 ZN	NUT M10X 1,5 D980 8 ZN	ECROU M10X 1,5 D980 8 ZN	MUTTER M10X 1,5 D980 8 ZN	TUERCA M10X 1,5 D980 8 ZN
31	GA7911160	ASS.BARRA SUPP.MOLLE 500				
32	F01020436	VITE M 8X1,25X 20 U5739 8.8 ZN	SCREW M8X1,25X20 U5739 8.8 ZN	VIS M8X1,25X20 U5739 8.8 ZN	SCHRA. M8X1,25X20 U5739 8.8 ZN	TORN. M8X1,25X20 U5739 8.8 ZN
33	F01410051	ROS.M8 8,4X 17X1,6 U6592 ZN	WASHER M8 8,4X17X1,6 U6592 ZN	RONDEL. M8 8,4X17X1,6 U6592 ZN	SCHEIBE M8 8,4X17X1,6 U6592 ZN	ARANDELA M8 8,4X17X1,6 U6592 ZN
34	F20110715	CAV.Q.M10X 1,5X 30 61X 80 ZN				
35	G15311740	PEDANA L.600	PLATFORM L.600	MARCHEPIED L600	TRITTBRETT L.2700	PLATAFORMA L 600
36	G17919480	PIATTO SUPP.SCALINO				
37	G17916990	ASS.SUPPORTO ERPICE LAT.				
38	G17917000	ASS.SUPPORTO MOLLE LAT.				
39	F20120346	PUNTALE Q 35 ALETT.POLIT.NERO				
40	F01020179	VITE M12X1,75X150 5737 8.8 ZN	SCREW M12X1,75X150 5737 8.8 ZN	VIS M12X1,75X150 5737 8.8 ZN	SCHRA.M12X1,75X150 5737 8.8 ZN	TORN. M12X1,75X150 5737 8.8 ZN
41	F01410076	ROS.M12 13X 24X2,5 U6592 ZN	PLANE WASHER D12 UNI 6592 ZN	RONDELLE D12 UNI 6592 ZN	SCHEIBE D12 UNI 6592 ZN	ARANDELA D12 UNI 6592 ZN
42	F01020083	VITE M 8X1,25X70 U5737 8.8 ZN	BOLT M 8X70	VIS M 8X70	SCHRAUBE M 8X70	TORNILLO M 8X70
43	G07000026	PIASTR.DENTI A MOLLA ZN	GALVAN. SPRING TOOTHED PLATE	PLAQUE DENTS A RESSORT ZN	PLATTE FEDERZZHNE ZN	PLACA DIENTES DE MUELLE ZN
44	G18903640	MOLLA CORTA COPRISEME D.9	SPEC. SPRING SHORT TOOTH D.9	DENT HERSE RECOUVR COURTE D.9	SPEZIALFEDER M. KURZ.ZAHN D.9	MUELLE ESPEC.DIENTE CORTO D.9
45	G18903650	MOLLA LUNGA COPRISEME D.9	SPEC. SPRING LONG TOOTH D.9	DENT HERSE RECOUVR LONGUE D.9	SPEZIALFEDER M. LANG.ZAHN D.9	MUELLE ESPEC.DIENTE LARGO D.9
46	GA7910710	ASS.TUBO SUPP.ERPICE 1250				
47	G16240400	TUBO INFERIORE ERPICE	LOWER HARROW TUBE	TUBE INFERIEUR HERSE	UNTERES ROHR EGGE	TUBO INFERIOR GRADA
48	G17917010	ASS.SUPPORTO ERPICE LAT.				
49	G16240430	TUBO INFERIORE ERPICE	LOWER HARROW TUBE	TUBE INFERIEUR HERSE	UNTERES ROHR EGGE	TUBO INFERIOR GRADA
50	G17917270	ASS.TUBO SUPPORTO ERICE 2000				

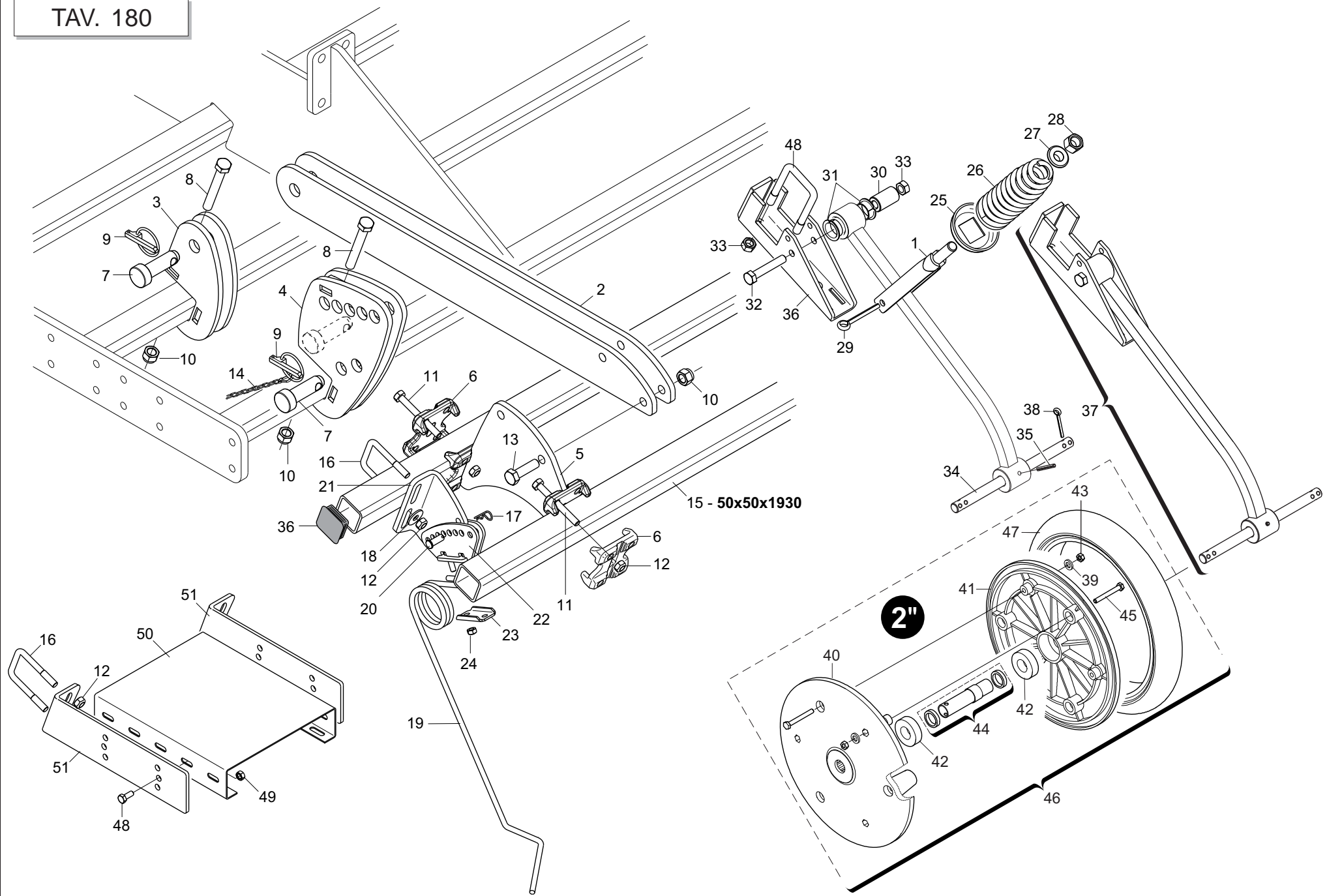

DOPPIO RUOTINO PREMISEME

TAV. 180

Pos.	Cod.	Descrizione	Description	Description	Benennung	Descripcion
1	G16940560	GUIDA MOLLA	SPRING GUIDE	GUIDAGE RESSORT	FEDERF_HRUNG	GU-A MUELLE
2	GA7910850	BARRA SOSTEGNO RUOTINI				
3	GA7910810	ASS.SUPP.BARRA RUOTINI				
4	GA7910900	ASS.REGOLAZ.PROFONDITA'				
5	GA7910800	ASS.SUPP.RUOTINI				
6	G19204230	SUPPORTO MANICOTTO TQ.50				
7	F20100048	PERNO D22 L48 C40 ZN				
8	F01020214	VITE M14X 2X100 U5737 8.8 ZN	BOLT 14X100 5737 8.G GALVANIZ.	VIS 14X100 5737 8.G ZN	SCHRAUBE 14X100 5737 8.G ZN	TORNILLO 14X100 5737 8.G ZN
9	F02200507	SPINA SCATTO D. 9 B/83 ZN	SNAP PIN D9 B/83 ZN	FICHE A DETENTE D9 B/83 ZN	EINRASTSTIFT D9 B/83 ZN	CLAVIJA DE MUELLE D9 B/83 ZN
10	F01230073	DADO M14X 2 D982 8 ZN	SELF LOCK. NUT M14X2 D982 8 ZN	ECROU AUTOBL. M14X2 D982 8 ZN	SELBSTSP.MUTT. M14X2 D982 8 ZN	TUERCA AUTOBL. M14X2 D982 8 ZN
11	F01020132	VITE M10X1,5X 90 U5737 10.9 ZD	SCREW M10X 1,5X 90 U5737 10.9Z	VIS M10X 1,5X 90 U5737 10.9ZG	SCHRAUBE M410X 1,5X 90 U5737 1	TORNIL. M10X 1,5X 90 U5737 10.
12	F01220033	DADO M10X 1,5 D980 8 ZN	NUT M10X 1,5 D980 8 ZN	ECROU M10X 1,5 D980 8 ZN	MUTTER M10X 1,5 D980 8 ZN	TUERCA M10X 1,5 D980 8 ZN
13	F01020547	VITE M14X 2X50 U5739 8.8 ZN	BOLT M14X2X50	VIS M14X2X50	SCHRAUBE M14X2X50	TORNILLO M14X2X50
14	G13812311	CATENELLA CON MOSCHETTONE	CHAIN WITH SPRING CATCH	CHAINETTE AVEC MOUSQUETON	KETTE MIT KARABINERHAKEN	CADENA CON GANCHO
15	G16710780	TUBO Q. 50X 4X1930				
16	F20110715	CAV.Q.M10X 1,5X 30 61X 80 ZN				
17	F02200342	COPIGLIA R 2X 50 ZN	SPLIT PIN R 2X50 ZN	GOUPILLE R 2X50 ZN	SPLINT R 2X50 ZN	CHAVETA R 2X50 ZN
18	F01420060	ROS.M10 10,5X 30X2,5 U6593 ZN	WASHER 10,5X30	RONDELLE 10,5X30	SCHEIBE 10,5X30	ARANDELA 10,5X30
19	G18904650	MOLLA COPRISEME X RUOTINI				
20	F02100336	PERNO D.10 UNI 1710 ZN	PIN D.10 UNI 1676/DIN 71752	PIVOT D.10 UNI 1676/DIN 71752	BOLZEN D.10 UNI 1676/DIN 71752	PERNO D.10 UNI 1676/DIN 71752
21	G17941020	ATTACCO REGOLAZ.PROFONDITA'				
22	G17941040	ASS.SUPP.MOLLA				
23	G07000026	PIASTR.DENTI A MOLLA ZN	GALVAN. SPRING TOOTHED PLATE	PLAQUE DENTS A RESSORT ZN	PLATTE FEDERZZHNE ZN	PLACA DIENTES DE MUELLE ZN
24	F01220022	DADO M 8X1,25 D980 8 ZN	NUT M8X 1,25 D980 8 ZN	ECROU M8X 1,25 D980 8 ZN	MUTTER M8X 1,25 D980 8 ZN	TUERCA M8X 1,25 D980 8 ZN
25	G16940540	RONDELLA FERMO MOLLA COMPRESS.	COMPRESS. SPRING LOCK WASHER	RONDELLE ARR-T RESSORT COMPRES	SPERRSCHEIBE DRUCKFEDER	ARANDELA DE TOPE MUELLE COMPRES
26	G16940510	MOLLA COMPRESSIONE ELEMENTO	ELEMENT COMPRESSION SPRING	RESSORT COMPRESSION +L+MENT	DRUCKFEDER ELEMENT	MUELLE COMPRESIÉN ELEMENTO
27	G17940931	BOCCOLA GUIDA MOLLA ZN				
28	F01230085	DADO M16X 2 D982 8 ZN	NUT M16X 2 D982 8 ZN	ECROU M16X 2 D982 8 ZN	MUTTER M16X 2 D982 8 ZN	TUERCA M16X 2 D982 8 ZN
29	F02200271	COPIGLIA 10X 40 U1336 ZN	SPLIT PIN 10 X40 1336 GALVAN.	GOUPILLE 10 X40 1336 ZN	SPLINT 10 X40 1336 ZN	PASADOR 10 X40 1336 ZN
30	G18803270	BOCCOLA 12 X25 X42				
31	F04150034	CUSCINETTO FLANGIATO 25X28X16				
32	F01020164	VITE M12X1,75X70 U5737 8.8 ZN	SCREW M12X1,75X70 U5737 8.8 ZN	VIS M12X1,75X70 U5737 8.8 ZN	SCHR. M12X1,75X70 U5737 8.8 ZN	TORN. M12X1,75X70 U5737 8.8 ZN
33	F01220048	DADO M12X1,75 D980 8 ZN	NUT M12X1,75 D980 8 ZN	ECROU M12X1,75 D980 8 ZN	SCHEIBE M12X1,75 D980 8 ZN	TUERCA M12X1,75 D980 8 ZN
34	G17940980	PERNO SUPP.RUOTE				
35	F02100091	SPINA E.P. 5X 45 U6873 C70 BR	PIN EL. .5 X45 DIN 1481	FICHE EL. 5 X45 DIN 1481	SPANNSTIFT 5 X45 DIN 1481	CLAVIJA EL.5 X45 DIN 1481
36	G16940991	ASS.SUPPORTO MOLLA				
37	G17941000	MONT.SUPP.DOPPIO RUOT.PREMIS.				
38	F02200227	COPIGLIA 5X 30 U1336 ZN	SPLIT PIN 5 X30 1336 GALVAN.	GOUPILLE 5 X30 1336 ZN	SPLINT 5 X30 1336 ZN	PASADOR 5 X30 1336 ZN
39	F01020070	VITE M 8X1,25X45 U5737 8.8 ZN	BOLT 8 X45 5737 8.G GALVANIZED	VIS 8 X45 5737 8.G ZN	SCHRAUBE 8 X45 5737 8.G ZN	TORNILLO 8 X45 5737 8.G ZN
40	F06120147	SEMICERCHIO PLA RUOTA 2"	PLASTIC HALF RIM 2" WHEEL	DEMI-JANTE PLAST. ROUE 2"	HALBFELGE PLA RAD 2"	SEMIARO PL-ST.RUEDA 2"
41	F06120146	SEMICERCHIO PLA RUOTA 1"	PLASTIC HALF RIM 1" WHEEL	DEMI-JANTE PLAST. ROUE 1"	HALBFELGE PLA RAD 1"	SEMIARO PL-ST.RUEDA 1"
42	F04010131	CUSC.D20 D42 B12 6004-2RSH EX>	BEARING 6004 2RS EX. SKF	ROULEMENT 6004	LAGER 6004	COJINETE 6004
43	F01230022	DADO M 6X 1 D982 8 ZN	NORM.SELF-LOCKING NUT 6 GALVAN	ECROU AUTOB.NOR.6 ZN	SELBSTSP. MUTTER NOR.6 ZN	TUERCA AUTOB. NOR. 6 ZN
44	G15226620	KIT DIST./GUARNIZIONI RUOTA V2				
45	F01020042	VITE M 6X 1X 50 U5737 8.8 ZN	BOL.M 6X 1X 50 U5737 8.8 ZG	VIS 6 X50 5737 8.G ZN	SCHRAUBE 6 X50 5737 8.G ZN	TORNILLO 6x50 5737 8.G ZN
46	F06120075	RUOTA DA 2 POLLICI MT	RUBBER WHEEL 2"X13' PLA.2 BEAR	ROUE CAOUTCHOUTEE	GUMMIRAD	RUEDA DE CAUCHO
47	F06120165	COPERTURA 2' X 13'	RUBBER RING 2X13'	COUVERT FARMF ROUE COMPR 2"X13'	MANTEL 2' X 13'	CUBIERTA 2' X 13'
48	F01020436	VITE M 8X1,25X 20 U5739 8.8 ZN	SCREW M8X1,25X20 U5739 8.8 ZN	VIS M8X1,25X20 U5739 8.8 ZN	SCHRA. M8X1,25X20 U5739 8.8 ZN	TORN. M8X1,25X20 U5739 8.8 ZN
49	F01260043	DADO FLANG.M8 D6923 8.8 ZN	FLANGE NUT M8 DIN 6923 8.8 GAL	ECROU BRIDE .M8 DIN 6923 8.8 Z	GEFLANSCHTE MUTTER M8 DIN6923	TUERCA BRIDA M8 DIN 6923 8.8 Z
50	G15171770	PEDANA 250X300X60 SP2 ZN				
51	G16242471	SUPPORTO SCALINO	STEP SUPPORT	SUPPORT MARCHE	STUFENHALTERUNG	SOPORTE ESCALON

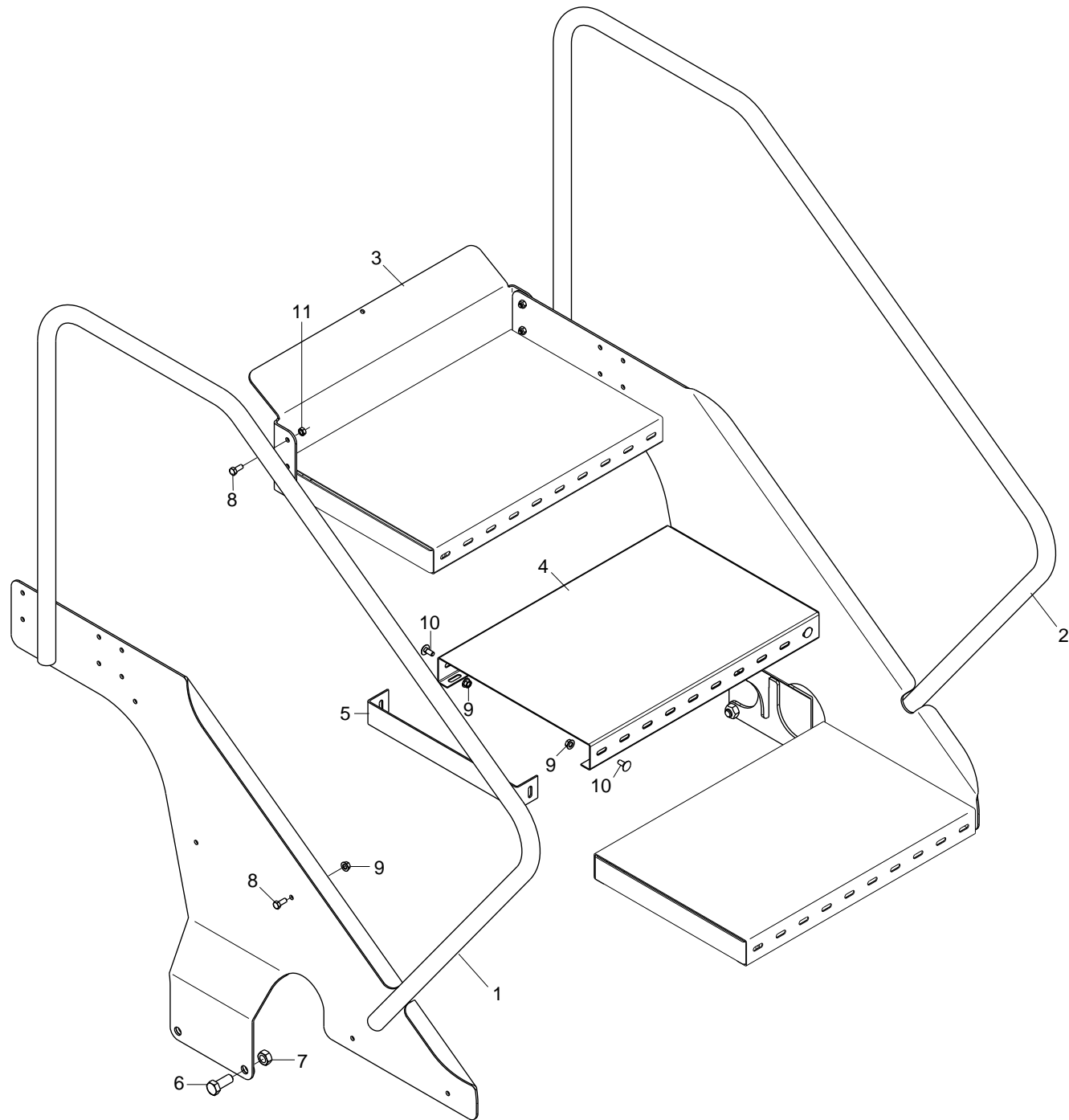

SCALETTA DI ISPEZIONE

TAV. 190

Pos.	Cod.	Descrizione	Description	Description	Benennung	Descripcion
1	GA7911010	ASS.SUPP.SCALINI SX				
2	GA7911020	ASS.SUPP.SCALINI DX				
3	G17915161	LAMA CONTENIMENTO FIANCATE				
4	G17917220	PEDANA 400 X 600 X 58 SP2 ZN>				
5	G16310680	TERMINALE PEDANA	GALVANIZED PLATFORM END	PIECE TERMINALE MARCHEPIED ZN	LAUFSTEGABSCHLUSS ZN	TERMINAL PLATAFORMA ZN
6	F01020566	VITE M16X 2X40 U5739 8.8 ZN	BOLTM16X2X40	VISM16X2X40	SCHRAUBE M16X2X40	TORNILLO M16X2X40
7	F01220266	DADO M16X 2 D980 8 ZN	NUT M16X 2 D980 8 ZN	ECROU M16X 2 D980 8 ZN	MUTTER M16X 2 D980 8 ZN	TUERCA M16X 2 D980 8 ZN
8	F01020436	VITE M 8X1,25X 20 U5739 8.8 ZN	SCREW M8X1,25X20 U5739 8.8 ZN	VIS M8X1,25X20 U5739 8.8 ZN	SCHRA. M8X1,25X20 U5739 8.8 ZN	TORN. M8X1,25X20 U5739 8.8 ZN
9	F01260043	DADO FLANG.M8 D6923 8.8 ZN	FLANGE NUT M8 DIN 6923 8.8 GAL	ECROU BRIDE .M8 DIN 6923 8.8 Z	GEFLANSCHTE MUTTER M8 DIN6923	TUERCA BRIDA M8 DIN 6923 8.8 Z
10	F01060040	BUL.M 8X1,25X 20 U5732 4.6 ZG	BOLT 8 X20 5732 4.6 GALVANIZED	VIS 8 X20 5732 4.6 ZN	SCHRAUBE 8 X20 5732 4.6 ZN	TORNILLO 8 X20 5732 4.6 ZN
11	F01220022	DADO M 8X1,25 D980 8 ZN	NUT M8X 1,25 D980 8 ZN	ECROU M8X 1,25 D980 8 ZN	MUTTER M8X 1,25 D980 8 ZN	TUERCA M8X 1,25 D980 8 ZN

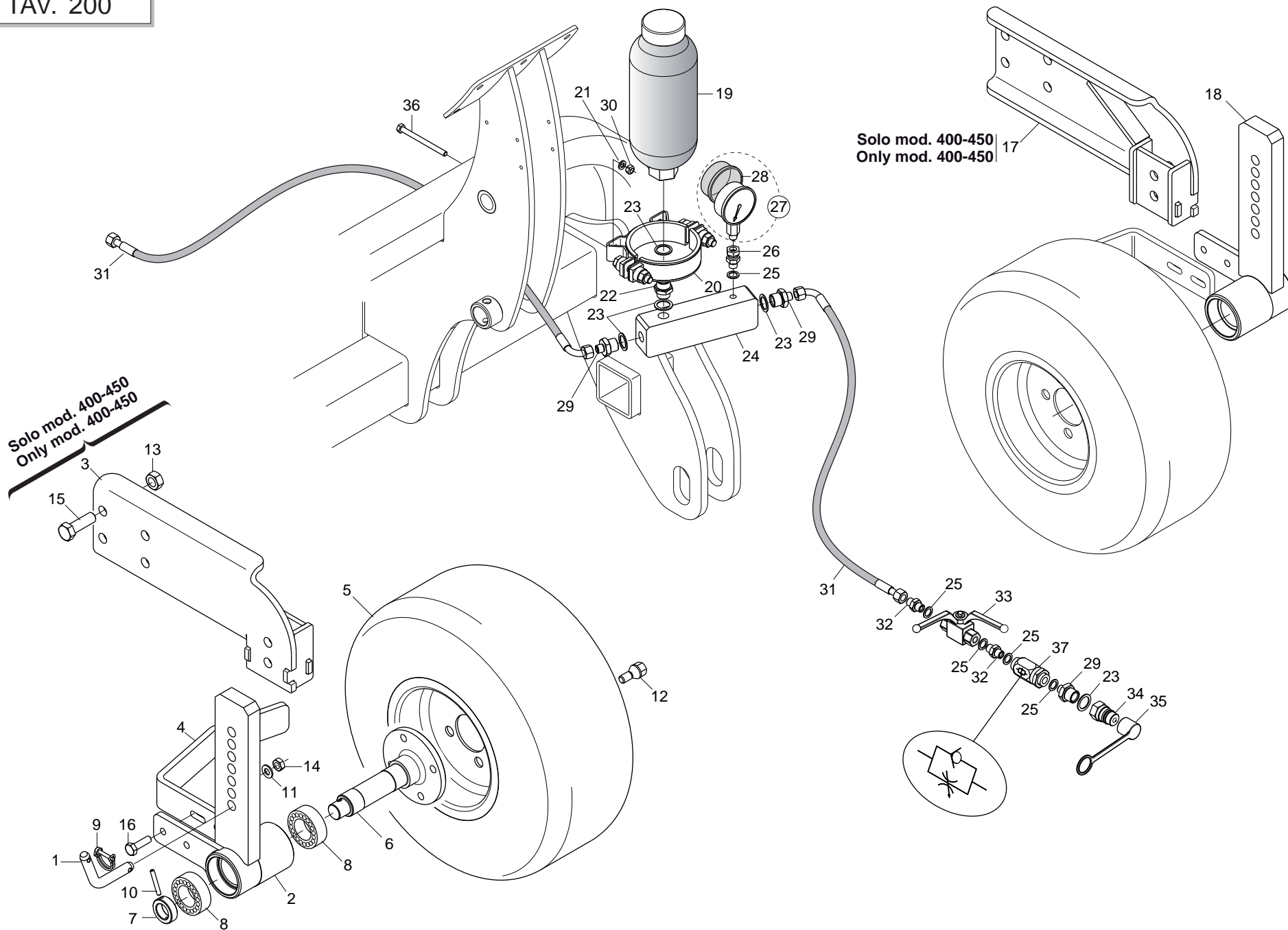

RUOTINI DI PROFONDITÀ

TAV. 200

Pos.	Cod.	Descrizione	Description	Description	Benennung	Descripcion
1	G17916010	PERNO FERMO RUOTINO ZN	GALVAN. WHEEL RETAINING PIN	PIVOT ARRET ROUET ZN	SPERRZAPFEN ROLLE ZN	PERNO BLOQUEO RUEDECILLA ZN
2	G17913901	ASS.SUPPORTO RUOTINO DX				
3	G17913891	ASS.SUPP.REGOLAZ.PROFOND.DX				
4	G17913870	LAMA RASCHIATERRA	SOIL SCRAPER BLADE	LAME RACLEUSE	MESSER ERDSCHABER	CUCHILLA RASCADOR TIERRA
5	G17913041	ASS.RUOTINO PROF.CAMERA D'ARIA				
6	G17913030	ASSE RUOTINO D.35	WHEEL AXLE	AXE ROUES	RZDERACHSEN	EJE RUEDAS
7	G16010080	BOCCOLA 25X40X13 ZN	BUSHING 25X40X13 ZN	BOITE 25X40X13 ZN	BÜCHSE 25X40X13 ZN	CASQUILLO 25X40X13 ZN
8	F04010345	CUSC.D35 D62 B20 63007 2RS1>	BEARING 63007 2RS1	PALIER 63007 2RS1	LAGER 63007 2RS1	COJINETE 63007 2RS1
9	F02200595	SPINOTTO X INGRANAGGIO				
10	F02100121	SPINA E.P. 6X 40 U6873 C70 BR	ELASTIC PIN 6X40	GOUJON ELASTIQUE 6X40	SPANNHUELSE 6X40	PASADOR 6X40
11	F01410064	ROS.M10 10,5X 20X 2 U6592 ZN	WASHER M10 10,5X20X2 U6592 ZN	RONDELL.M10 10,5X20X2 U6592 ZN	SCHEIBE M10 10,5X20X2 U6592 ZN	ARAND. M10 10,5X20X2 U6592 ZN
12	F01250028	DADO COLON.CON.60°M12X20 ZN	STUD BOLT M12X20 ZN	COLONNETTE M12X20 ZN	SCHRAUBBOLZEN M12X20 ZN	ESP-RRAGO M12X20 ZN
13	F01230085	DADO M16X 2 D982 8 ZN	NUT M16X 2 D982 8 ZN	ECROU M16X 2 D982 8 ZN	MUTTER M16X 2 D982 8 ZN	TUERCA M16X 2 D982 8 ZN
14	F01220033	DADO M10X 1,5 D980 8 ZN	NUT M10X 1,5 D980 8 ZN	ECROU M10X 1,5 D980 8 ZN	MUTTER M10X 1,5 D980 8 ZN	TUERCA M10X 1,5 D980 8 ZN
15	F01020252	VITE M16X 2X 50 U5737 8.8 ZN	SCREW M16X 2X 50 U5737 8.8 ZN	VIS M16X 2X 50 U5737 8.8 ZN	SCHR. M16X 2X 50 U5737 8.8 ZN	TORN. M16X 2X 50 U5737 8.8 ZN
16	F01020479	VITE M10X 1,5X35 U5739 8.8 ZN	SCREW M10X1,5X35 U5739 8.8 ZN	VIS M10X1,5X35 U5739 8.8 ZN	SCHR. M10X1,5X35 U5739 8.8 ZN	TORN. M10X1,5X35 U5739 8.8 ZN
17	G17913861	ASS.SUPP.REGOLAZ.PROFOND.SX				
18	G17913851	ASS.SUPPORTO RUOTINO SX				
19	F03151286	ACCUMULATORE AZOTO 1,5L 20BAR				
20	F02350056	STAFFA FISSAGGIO ACCUMULATORE				
21	F01410051	ROS.M8 8,4X 17X1,6 U6592 ZN	WASHER M8 8,4X17X1,6 U6592 ZN	RONDEL. M8 8,4X17X1,6 U6592 ZN	SCHEIBE M8 8,4X17X1,6 U6592 ZN	ARANDELA M8 8,4X17X1,6 U6592ZN
22	F03150255	NIPPLO MASCH.CIL.1/2-1/2 ZN	NIPLE 1/2"GAS	NIPLE 1/2"GAS	NIPLE 1/2"GAS	NIPLE 1/2"GAS
23	F03151237	ROS. 21 X27X1,5 RAME -1/2"	COPPER WASHER 21X27X1,5 1/2	RONDELLE CUIVRE 1/2 21X27X1,5	SCHEIBE KUPFER 1/2 21X27X1,5	ARANDELA COBRE 1/2 21X27X1,5
24	G17916270	PIATTO SUPPORTO RACCORDO IDR.	SUPPORT	SUPPORT	HALTERUNG	SOPORTE
25	F01500012	RONDELLA IN RAME 1/4"	WASHER	RONDELLE	SCHEIBE	ARANDELA
26	F03151180	NIPPLO M-F-GIREV.1/4 ZN X MAN.	NIPPLE M-F SW.1/4ZN FOR SLEEVE	NIPPLE M-F- TOURNANT a ZN X MA	NIPPEL M-F DREHB. 1/4 ZN F. MU	NIPLE M-H GIRAT.1/4 ZN X MAN.
27	F03151163	MANOMETRO 250 BAR ATTACCO 1/4'	PRESSURE 250 BAR	MANOMETRE DE 0 A 250 BARS	MANOMETER VON 0 BIS 250 B	MANMETRO DE 0 A 250 BAR M
28	F03151263	CUFFIA PROTEZ.MANOM.F03151163				
29	F03150211	NIPPLO MM CIL-CIL 1/2-1/4 ZN	NIPLE 1/4-1/2	NIPLE 1/4-1/2	NIPLE 1/4-1/2	NIPLE 1/4-1/2
30	F01220222	DADO TRISTOP M 8	NUT- TRISTOP M 8	ECROU TRISTOP M 8	MUTTER TRISTOP M 8	TUERCA TRISTOP M 8
31	G21210001	TUBO 1/4 R2 C-F 1/4 L.1600	PIPE 1/4 R1 C-F 1/4 L.1600	TUBE 1/4 R1 C-F 1/4 L. 1600	ROHR 1/4 R1 C-F 1/4 L. 1600	TUBO 1/4 R1 C-F 1/4 L.1600
32	F03150266	NIPPLO MM CIL-CIL 1/4-1/4 ZN	NIPPLE GALV.CYL.MALE 1/4 ZN	NIPPLE MALE CYL. 1/4 ZN	NIPPELZYL.1/4 ZN	NIPLE MACHO CIL.1/4 ZN
33	F03151245	RUBINETTO F-F 1/4	COCK F.-F. 1/4"	ROBINET F.-F. 1/4"	HAHN F.-F. 1/4"	GRIFO H.-H. 1/4"
34	F03150935	INNESTO RAP.MASCH.1/2 A VALV.	QUICK CONNECT MALE CONE 1/2	CONNEXION RAPIDE MALE CONE 1/2	SCHNELLKUPP.GEWINDE KONISC 1/2	ACOPLAMIENTO.RAP.MACHO CONO 1/2
35	F05150325	CAPPUC.F X INN.M RAP.1/2 ROSSO	COVER CONNECT F 1/2 RED	COUVERCLE CONNEXION F 1/2 ROSE	DECKEL W 1/2 SCHNELLKUPP. ROT	PAC PROTECCION F 1/2 ROJO
36	F01020090	VITE M8X1,25X100 U5737 8.8 ZN	BOLT 8 X100 5737 8.G GALVANIZ.	VIS 8 X100 5737 8.G ZN	SCHRAUBE 8 X100 5737 8.G ZN	TORNILLO 8 X100 5737 8.G ZN
37	F03151226	REGOL.DI FLUSSO VRF 1/4' GAS	1/4' GAS VALVE VRF	SOUPAPE REG DEBIT VRF 1/4" GAZ	VENITL VRF 1/4' GAS	VæLVULA VRF 1/4' GAS

TRATTORE - TRACTOR

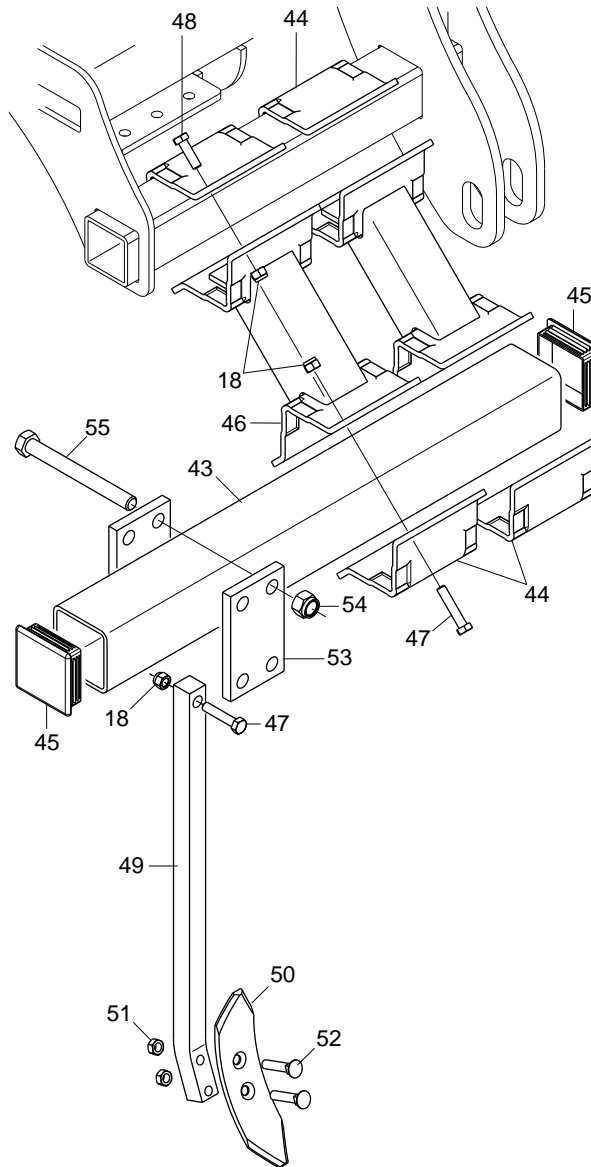
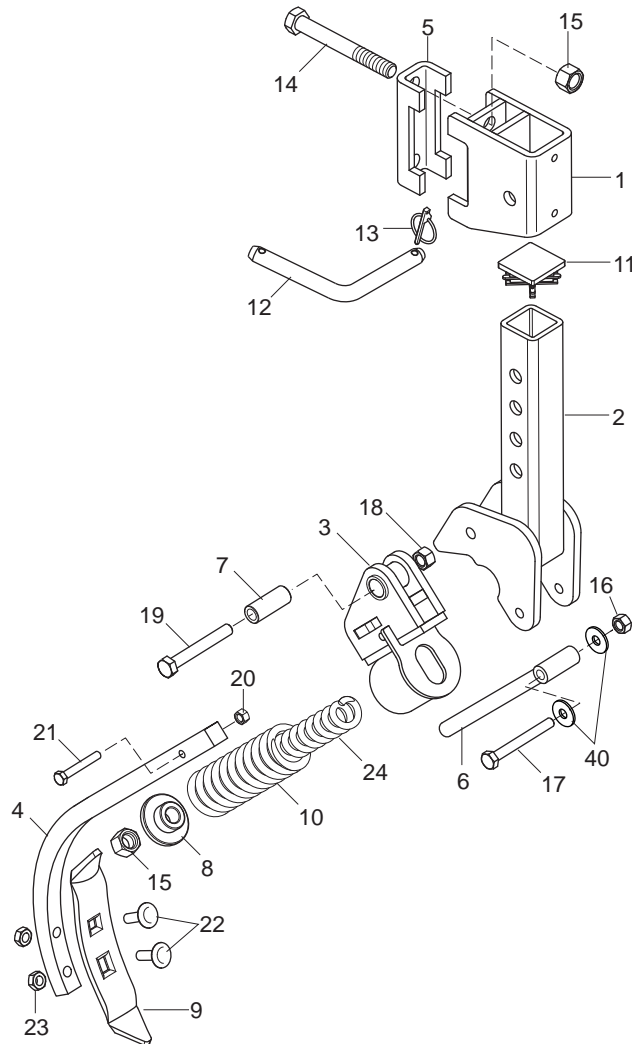

SEMINATRICE - SEED DRILL

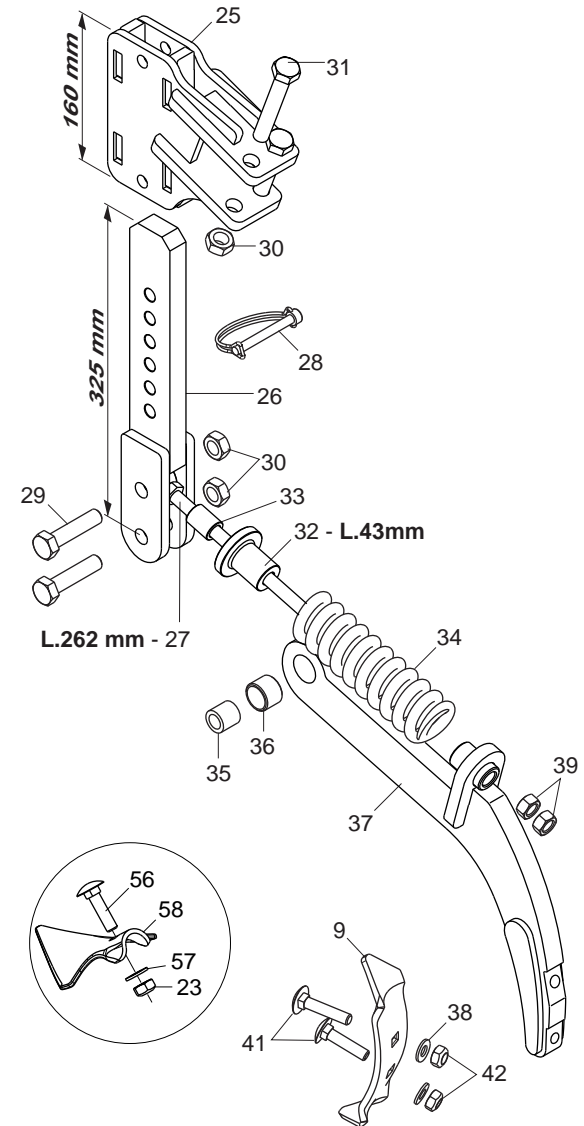

ROMPITRACCIA

TAV. 210

Pos.	Cod.	Descrizione	Description	Description	Benennung	Descripcion
1	G17940170	PIASTRA DI BATTUTA	PLATE	PLAQUE	PLATTE	PLACA
2	G17940340	TUBO REGOLAZIONE PROFOND.	ADJUSTMENT TUBE	TUBE REGLAGE	ROHR EINSTELLUNG	TUBO REGULACIEN
3	G17940290	SUPPORTO MOLLA	SPRING SUPPORT BRACKET	+TRIER SUPPORT RESSORT	FEDERHALTB. GEL	ESTRIBO SOPORTE MUELLE
4	G17940060	MOLLA OPERATRICE	OPERATING SPRING	RESSORT DE FONCTIONNEMENT	ARBEITSFEDER	ARBEITSFEDER
5	G36200241	SCONTRO U Q.80	FLANGE 'U' 80	BRIDE 'U' 80	ANSCHLAG 'U' 80	ELEMENTO DE EMPALME 'U' 80
6	G17940200	ASS.ASSE DI REGOLAZIONE ZN	GALVAN. ADJUSTMENT AXLE ASSEMB	ASS. AXE DE REGLAGE ZINGUE	EINSTELLUNGSEINHEIT ACHSE ZN	ASS. EJE DE REGULACION ZN
7	G17940390	BOCCOLA 12X20X50	BUSHING 12X20X50	BOITE 12X20X50	B. CHSE 12X20X50	CASQUILLO 12X20X50
8	G17940260	FONDELLO PER MOLLA	SPRING BOTTOM	CULOT POUR RESSORT	BODENSCHLEIBE F_R FEDER	FONDO PARA MUELLE
9	G16941020	VOMERE MOLLA ELEMENTO	PLOWSHARE SPRING ELEMENT	SOC RESSORT ELEMENT	PFLUGSCHAR FEDER ELEMENT	REJA MUELLE ELEMENTO
10	G18904201	MOLLA ELEMENTO OPERATORE ZN	OPERADORES ELEMENT SPRING	RESSORT ELEMENT OPERATEUR	FEDER ELEMENT FAHRER	MUELLE ELEMENTO OPERADOR
11	F20120349	PUNTALE Q.50 ALETT. POLIT. NERO				
12	G17916060	PERNO REGOLAZIONE MOLLA ZN	ADJUSTMENT PIN	PIVOT REGL.	EINSTELLZAPFEN	PERNO REGULAC.
13	F02200463	SPINA SCATTO D. 5 B/81 ZN	SNAP PIN D5 B/81 ZN	FICHE A DETENTE D5 B/81 ZN	EINRASTSTIFT D5 B/81 ZN	CLAVIJA DE MUELLE D5 B/81 ZN
14	F01020268	VITE M16X 2X130 U5737 8.8 ZN	SCREW 16X130 5737 8.G GALVAN.*	VIS 16X130 5737 8.G ZN *	SCHRAUBE 16X130 5737 8.G ZN	TORNILLO 16X130 5737 8.G ZN
15	F01230085	DADO M16X 2 D982 8 ZN	NUT M16X 2 D982 8 ZN	ECROU M16X 2 D982 8 ZN	MUTTER M16X 2 D982 8 ZN	TUERCA M16X 2 D982 8 ZN
16	F01230048	DADO M10X 1,5 D982 8 ZN	NUT AUTOBLOC. M10 ZB	ECROU AUTOBLOC. M10 ZB	SCHEIBE AUTOBLOC. M10 ZB	TUERCA AUTOBLOC M10 ZB
17	F01020132	VITE M10X1,5X 90 U5737 10.9 ZD	SCREW M10X 1,5X 90 U5737 10.9Z	VIS M10X 1,5X 90 U5737 10.9ZG	SCHRAUBE M410X 1,5X 90 U5737 1	TORNIL. M10X 1,5X 90 U5737 10.
18	F01230059	DADO M12X1,75 D982 8 ZN	NUT M12X1,75 D982 8 ZN	ECROU M12X1,75 D982 8 ZN	MUTTER M12X1,75 D982 8 ZN	TUERCA M12X1,75 D982 8 ZN
19	F01020168	VITE M12X1,75X90 U5737 8.8 ZN	SCREW M12X1,75X90 U5737 8.8 ZN	VIS M12X1,75X90 U5737 8.8 ZN	SCHR. M12X1,75X90 U5737 8.8 ZN	TORN. M12X1,75X90 U5737 8.8 ZN
20	F01230034	DADO M 8X1,25 D982 8	SELF LOCK.NUT M8X1,25 D982 8ZN	ECROU AUTOBL.M8X1,25 D982 8 ZN	SELBST.MUTT.M8X1,25 D982 8 ZN	TUERCA AUTO. M8X1,25 D982 8 ZN
21	F01020077	VITE M 8X1,25X60 U5737 8.8 ZN	SCREW M8X1,25X60 U5737 8.8 ZN	VIS M8X1,25X60 U5737 8.8 ZN	SCHRA. M8X1,25X60 U5737 8.8 ZN	TORN. M8X1,25X60 U5737 8.8 ZN
22	F01060500	BUL.M10X 1,5X 45 5735 8.G BR	SCREW 10X45 5735 8.G BR	VIS 10X45 5735 8.G BR.	SCHRAUBE 10X45 5735 8.G BR.	TORNILLO 10X45 5735 8.G BR.
23	F01220033	DADO M10X 1,5 D980 8 ZN	NUT M10X 1,5 D980 8 ZN	ECROU M10X 1,5 D980 8 ZN	MUTTER M10X 1,5 D980 8 ZN	TUERCA M10X 1,5 D980 8 ZN
24	G18904380	MOLLA COMPRESSIONE SU MOLLA ZN	COMPRESSION SPRING ZN	RESSORT COMPRESSION ZN	DRUCKFEDER ZN	MUELLE COMPRESIEN ZN
25	G17914272	ASS.SUPPORTO ROMPITRACCIA				
26	G17914352	ASS.REGOLAZIONE PROFONDITA'				
27	G17914401	VITE DI REGOLAZIONE ZN				
28	F02200584	SPINA SICUR. D. 12X70 ZN	PIN D12 L70 ZN	FICHE D12 L70 ZN	STIFT D12 L70 ZN	CLAVIJA D12 L70 ZN
29	F01020203	VITE 14X 2X 60 U5737 8.8 ZN	BOLT M 14X60	VIS M 14X60	SCHRAUBE M 14X60	TORNILLO M 14X60
30	F01220255	DADO M14X 2 D980 8 ZN	NUT- TRISTOP M14X2 D980 8 ZN	ECROU TRISTOP M14X2 D980 8 ZN	MUTTER TRISTOP M14X2 D980 8 ZN	TUERCA TRISTOP M14X2 D980 8 ZN
31	F01020212	VITE M14X 2X 90 U5737 8.8 ZN	SCREW M14X 2X 90 U5737 8.8 ZN	VIS M14X 2X 90 U5737 8.8 ZN	SCHARUBE M14X2X90 U5737 8.8 ZN	TORNILLO M14X2X90 U5737 8.8 ZN
32	G17914422	TONDO GUIDA E BATTUTA MOLLA ZN				
33	G18801560	BOCCOLA 12,5 X20 X26,5 ZN	BUSHING 12.5 X 20 X 26.5- GALV	BOITE 12-5 X20 X26-5 ZN	BsCHSE 12-5 X20 X26-5 ZN	CASQUILLO 12-5 X20 X26-5 ZN
34	G18904200	MOLLA ELEMENTO OPERATORE ZN	OPERATOR/AES ELEMENT SPRING	RESSORT ELEMENT OPERATEUR	FEDER ELEMENT FAHRER	MUELLE ELEMENTO OPERADOR
35	G17914380	BOCCOLA 14,25X22X21 ZN	BUSHING 14,25X22X21 ZN	BOITE 14,25X22X21 ZN	BUCHSE 14,25X22X21 ZN	CASQUILLO 14,25X22X21 ZN
36	G17914370	BOCCOLA 22,25X27X20 ZN	BUSHING 22,25X27X20 ZN	BOITE 22,25X27X20 ZN	BUCHSE 22,25X27X20 ZN	CASQUILLO 22,25X27X20 ZN
37	G17914322	ASS.SUPPORTO VOMERE				
38	F01430023	ROS.M10 10,5X 18X0,9 U8842J ZN	WASHER D10 DIN 6798 D.INT.ZN	RONDELLE D10 DIN 6798 D. INT.	UNT. SCHEIBE D10 DIN 6798 D.IN	ARANDELA D10 DIN 6798 D.INT.ZN
39	F01200293	DADO M12X1,75 U5588 6.8 ZN	NUT M12X1,75 U5588 6.8 ZN	ECROU M12X1,75 U5588 6.8 ZN	MUTTER M12X1,75 U5588 6.8 ZN	TUERCA M12X1,75 U5588 6.8 ZN
40	F01420060	ROS.M10 10,5X 30X2,5 U6593 ZN	WASHER 10,5X30	RONDELLE 10,5X30	SCHEIBE 10,5X30	ARANDELA 10,5X30
41	F01060114	BUL.M10X 1,5X 50 U6104 4.6 BR	BOLT M 10X50 6104 4.6	BOULON M 10X50 6104 4.6	SCHRAUBE M 10X50 6104 4.6	PERNO M 10X50 6104 4.6
42	F01200270	DADO M10X 1,5 U5588 6.8 ZN	NUT M10X 1,5 U5588 6.8 ZN	ECROU M10X 1,5 U5588 6.8 ZN	MUTTER M10X 1,5 U5588 6.8 ZN	TUERCA M10X 1,5 U5588 6.8 ZN
43	G14210030	TUBO Q.100X6X 849				
44	G16122200	PIASTRA ATTACCO DISCHI				
45	F03150772	TAPPO X TUBO 100X100 SP.5-6	PROTECTION PLUG 100 SP.5-6	BOUCHON DE PROTECTION 100 SP.5	SCHUTZPFROPFEN 100 SP.5-6	TAPN DE PROTECCIN 100 SP.5-6
46	GA7910980	ASS.SUPP.ROMPITRACCIA				
47	F01020188	VITE M12X1,75X60 U5737 10.9 ZD	SCREW M12X1,75X 60 U5737 10.9Z	VIS M12X1,75X 60 U5737 10.9ZG	SCHRAUBE M12X1,75X 60 U5737 10	TORNIL. M12X1,75X 60 U5737 10.
48	F01020528	VITE M12X1,75X40 U5739 10.9 ZD	SCREW 12X40 5739 10.9 ZN	VIS 12X40 5739 10.9 ZN	SCHRAUBE 12X40 5739 10.9 ZN	TORNILLO 12X40 5739 10.9 ZN
49	F20120340	MOLLA ROMPITRACCIA 30X30	WIPERMARK SPRING 30X30	RESSORT PAILLASS. TRACES 30X30	FEDER ZEICHEN MATTE 30X30	MUELLE LIMPIABARROS 30X30
50	F20120071	VOMERE REVERSIBILE 65X8X255				
51	F01220048	DADO M12X1,75 D980 8 ZN	NUT M12X1,75 D980 8 ZN	ECROU M12X1,75 D980 8 ZN	SCHEIBE M12X1,75 D980 8 ZN	TUERCA M12X1,75 D980 8 ZN
52	F20120041	BULLONE M12X60				
53	R18515700	PLACA PRINDERE SCORMONITOR				
54	F01230131	DADO M20X 2,5 D982 6 ZN	NUT M20X 2,5 D982 6 ZN	ECROU M20X 2,5 D982 6 ZN	MUTTER M20X 2,5 D982 6 ZN	TUERCA M20X 2,5 D982 6 ZN
55	F01020322	VITE M20X2,5X190 U5737 10.9 ZD	SCREW M20X2,5X190 5737 10.9 ZN	VIS M20X2,5X190 5737 10.9 ZN	SCHRA. M20X2,5X190 5737 10.9 ZN	TORN. M20X2,5X190 5737 10.9 ZN
56	F01060113	BUL.M10X 1,5X 40 U6104 4.6 BR	SCREW 10X40 6104 4.6	BOULON 10X40 6104 4.6	SCHRAUBE 10X40 6104 4.6	PERNO 10X40 6104 4.6
57	F01410064	ROS.M10 10,5X 20X 2 U6592 ZN	WASHER M10 10,5X20X2 U6592 ZN	RONDELL.M10 10,5X20X2 U6592 ZN	SCHEIBE M10 10,5X20X2 U6592 ZN	ARAND. M10 10,5X20X2 U6592 ZN
58	F20120102	ZAPPETTA PICC. PER MOLLE	HOE BLADE-SMALL-FOR SPRINGS	BINETTE PETITE POUR RESSORTS	KLEINES MESSER F. FEDERN	SALLETE PEQ. PARA MUELLE

TAV. 220

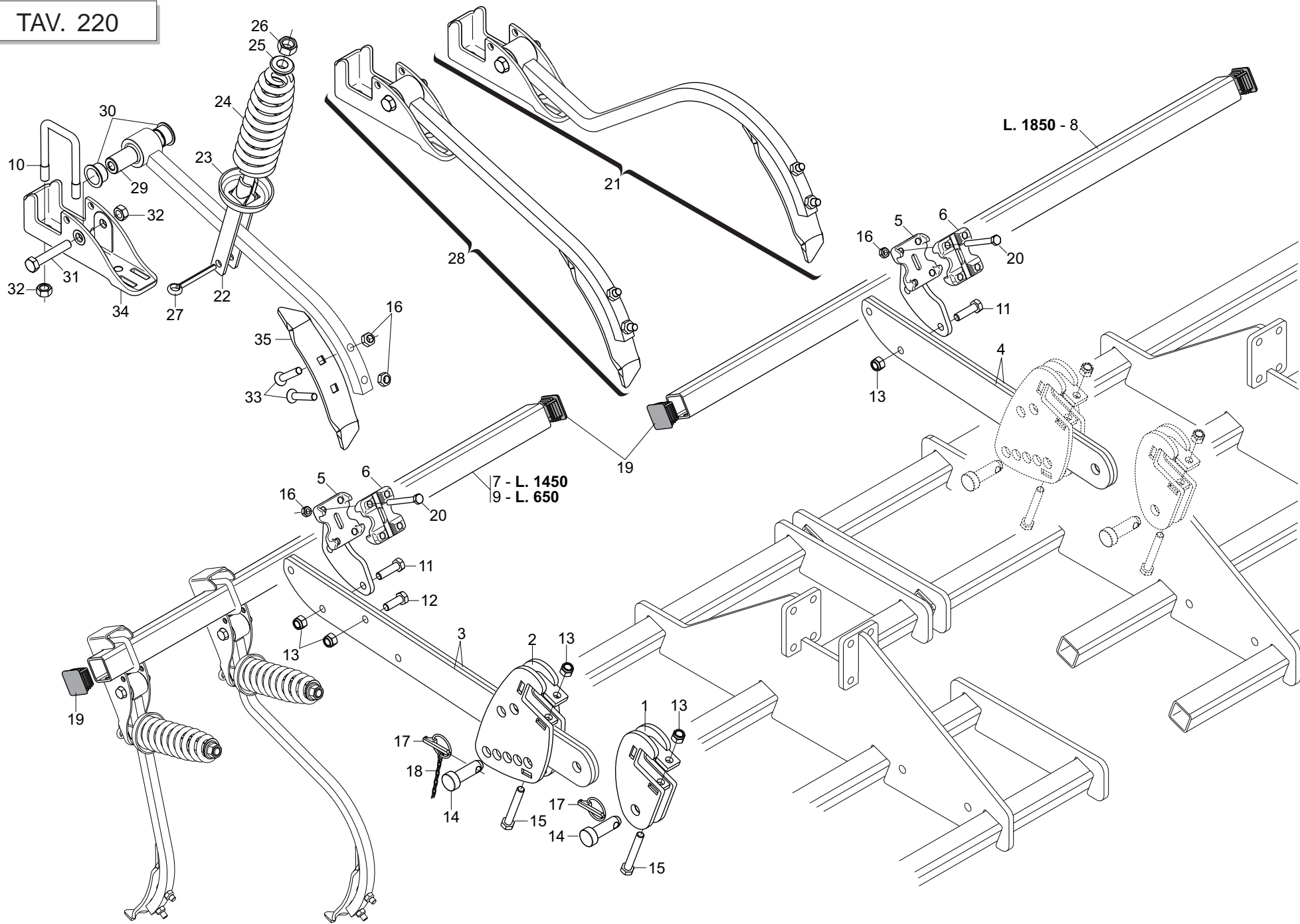

PREPARATORE ANTERIORE

TAV. 220

Pos.	Cod.	Descrizione	Description	Description	Benennung	Descripcion
1	GA7910810	ASS.SUPP.BARRA RUOTINI				
2	GA7910900	ASS.REGOLAZ.PROFONDITA'				
3	GA7910850	BARRA SOSTEGNO RUOTINI				
4	GA7910950	BARRA SOSTEGNO PREPARATORE				
5	GA7910920	ASS.SUPP.PREPARATORE				
6	G19204230	SUPPORTO MANICOTTO TQ.50				
7	G14215710	TUBO Q. 50X 4X1450 FORO D.10				
8	GA7910940	TUBO Q. 50X 4X1850				
9	G15311560	TUBO Q. 50X 4X 950				
10	F20110740	CAV.Q.M12X1,75X 35 63X 98 ZN	U BOLT M12X63 -95 ZN	CAVALIER M12X63 -95 ZN	VERBINDUNG M12X63 -95 ZN	PERNO EN U M12X63 -95 ZN
11	F01020547	VITE M14X 2X50 U5739 8.8 ZN	BOLT M14X2X50	VIS M14X2X50	SCHRAUBE M14X2X50	TORNILLO M14X2X50
12	F01020544	VITE M14X 2X40 U5739 8.8 ZN	BOLT M14X2X40	VIS M14X2X40	SCHRAUBE M14X2X40	TORNILLO M14X2X40
13	F01230073	DADO M14X 2 D982 8 ZN	SELF LOCK. NUT M14X2 D982 8 ZN	ECROU AUTOBL. M14X2 D982 8 ZN	SELBSTSP.MUTT. M14X2 D982 8 ZN	TUERCA AUTOBL. M14X2 D982 8 ZN
14	F20100048	PERNO D22 L48 C40 ZN				
15	F01020214	VITE M14X 2X100 U5737 8.8 ZN	BOLT 14X100 5737 8.G GALVANIZ.	VIS 14X100 5737 8.G ZN	SCHRAUBE 14X100 5737 8.G ZN	TORNILLO 14X100 5737 8.G ZN
16	F01220033	DADO M10X 1,5 D980 8 ZN	NUT M10X 1,5 D980 8 ZN	ECROU M10X 1,5 D980 8 ZN	MUTTER M10X 1,5 D980 8 ZN	TUERCA M10X 1,5 D980 8 ZN
17	F02200507	SPINA SCATTO D. 9 B/83 ZN	SNAP PIN D9 B/83 ZN	FICHE A DETENTE D9 B/83 ZN	EINRASTSTIFT D9 B/83 ZN	CLAVIJA DE MUELLE D9 B/83 ZN
18	G13812311	CATENELLA CON MOSCHETTONE	CHAIN WITH SPRING CATCH	CHAINETTE AVEC MOUSQUETON	KETTE MIT KARABINERHAKEN	CADENA CON GANCHO
19	F20120349	PUNTALE Q.50 ALETT.POLIT.NERO				
20	F01020132	VITE M10X1,5X 90 U5737 10.9 ZD	SCREW M10X 1,5X 90 U5737 10.9Z	VIS M10X 1,5X 90 U5737 10.9ZG	SCHRAUBE M410X 1,5X 90 U5737 1	TORNIL. M10X 1,5X 90 U5737 10.
21	G17941080	MONT.MOLLA PIEGATA				
22	G16940560	GUIDA MOLLA	SPRING GUIDE	GUIDAGE RESSORT	FEDERF_HRUNG	GU-A MUELLE
23	G16940540	RONDELLA FERMO MOLLA COMPRESS.	COMPRESS. SPRING LOCK WASHER	RONDELLE ARR-T RESSORT COMPRES	SPERRSCHEIBE DRUCKFEDER	ARANDELA DE TOPE MUELLE COMPRES
24	G18904660	MOLLA COPRISEME PREPARATORE ZN				
25	G17940931	BOCCOLA GUIDA MOLLA ZN				
26	F01230085	DADO M16X 2 D982 8 ZN	NUT M16X 2 D982 8 ZN	ECROU M16X 2 D982 8 ZN	MUTTER M16X 2 D982 8 ZN	TUERCA M16X 2 D982 8 ZN
27	F02200271	COPIGLIA 10X 40 U1336 ZN	SPLIT PIN 10 X40 1336 GALVAN.	GOUPILLE 10 X40 1336 ZN	SPLINT 10 X40 1336 ZN	PASADOR 10 X40 1336 ZN
28	G17941110	MONT.MOLLA				
29	G18803270	BOCCOLA 12 X25 X42				
30	F04150034	CUSCINETTO FLANGIATO 25X28X16				
31	F01020164	VITE M12X1,75X70 U5737 8.8 ZN	SCREW M12X1,75X70 U5737 8.8 ZN	VIS M12X1,75X70 U5737 8.8 ZN	SCHR. M12X1,75X70 U5737 8.8 ZN	TORN. M12X1,75X70 U5737 8.8 ZN
32	F01220048	DADO M12X1,75 D980 8 ZN	NUT M12X1,75 D980 8 ZN	ECROU M12X1,75 D980 8 ZN	SCHEIBE M12X1,75 D980 8 ZN	TUERCA M12X1,75 D980 8 ZN
33	F01060114	BUL.M10X 1,5X 50 U6104 4.6 BR	BOLT M 10X50 6104 4.6	BOULON M 10X50 6104 4.6	SCHRAUBE M 10X50 6104 4.6	PERNO M 10X50 6104 4.6
34	G16940991	ASS.SUPPORTO MOLLA				
35	G16941020	VOMERE MOLLA ELEMENTO	PLOWSHARE SPRING ELEMENT	SOC RESSORT ELEMENT	PFLUGSCHAR FEDER ELEMENT	REJA MUELLE ELEMENTO
36	F20120349	PUNTALE Q.50 ALETT.POLIT.NERO				

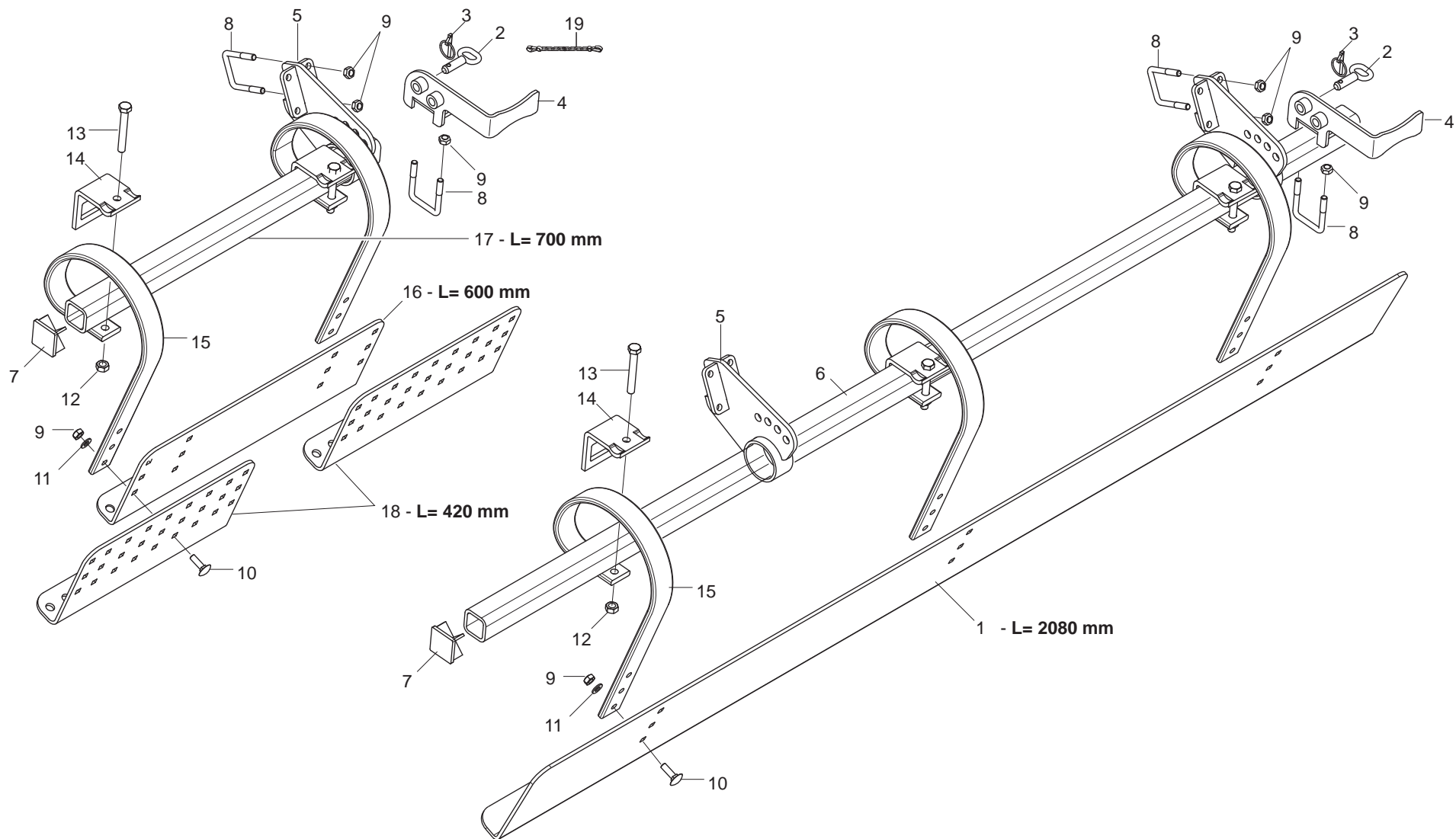

SPIANATERRA ANTERIORI

TAV. 230

Pos.	Cod.	Descrizione	Description	Description	Benennung	Descripcion
1	G17916110	LAMA LIVELLATRICE CENTRALE	CENTRAL LEVELLER BLADE	LAME NIVELEUR CENTRAL	ZENTRALE MESSER NIVELLIEREINH.	CUCHILLA NIVELADORA CENTRAL
2	G17911790	SPINA ZN	PIN ZN	GOUPILLE ZN	BOLZENSTIFT ZN	PASADOR ZN
3	F02200463	SPINA SCATTO D. 5 B/81 ZN	SNAP PIN D5 B/81 ZN	FICHE A DETENTE D5 B/81 ZN	EINRASTSTIFT D5 B/81 ZN	CLAVIJA DE MUELLE D5 B/81 ZN
4	G17911750	REGOLAZIONE ANGOLO LAVORO	ROTATION LEVER	LEVIER DE ROTATION	DREHEBEL	PALANCA DE ROTACION
5	G17911721	ROTAZIONE ASSE	SUPPORT PIPE	SUPPORT TUBE	ROHRHALTERUNG	SOPORTE TUBO
6	R17011640	TUBO Q. 50X 4X1750	GALVAN. SQUARE 50X 4X1750	TUBE CARRE 50X 4X1750	ROHR Q. 50X 4X1750	TUBO CUADRADO 50X 4X1750
7	F20120349	PUNTALE Q.50 ALETT.POLIT.NERO				
8	F20110715	CAV.Q.M10X 1,5X 30 61X 80 ZN				
9	F01220033	DADO M10X 1,5 D980 8 ZN	NUT M10X 1,5 D980 8 ZN	ECROU M10X 1,5 D980 8 ZN	MUTTER M10X 1,5 D980 8 ZN	TUERCA M10X 1,5 D980 8 ZN
10	F01060076	BUL.M10X 1,5X 40 U5732 4.6 BR	SCREW M10X1,5X40 U5732 8.8 ZN	VIS M10X 1,5X40 U5732 8.8 ZN	SCHR. M10X 1,5X40 U5732 8.8 ZN	TORN. M10X 1,5X40 U5732 8.8 ZN
11	F01410064	ROS.M10 10,5X 20X 2 U6592 ZN	WASHER M10 10,5X20X2 U6592 ZN	RONDELL.M10 10,5X20X2 U6592 ZN	SCHEIBE M10 10,5X20X2 U6592 ZN	ARAND. M10 10,5X20X2 U6592 ZN
12	F01220048	DADO M12X1,75 D980 8 ZN	NUT M12X1,75 D980 8 ZN	ECROU M12X1,75 D980 8 ZN	SCHEIBE M12X1,75 D980 8 ZN	TUERCA M12X1,75 D980 8 ZN
13	F01020168	VITE M12X1,75X90 U5737 8.8 ZN	SCREW M12X1,75X90 U5737 8.8 ZN	VIS M12X1,75X90 U5737 8.8 ZN	SCHR.M12X1,75X90 U5737 8.8 ZN	TORN. M12X1,75X90 U5737 8.8 ZN
14	G67002042	STAFFA 70X8	BRACKET 70X8	BRIDE 70X8	BsGEL 70X8	ABRAZADERA 70X8
15	F20120336	MOLLA LIVELLATRICE S.VOMERE	LEVELLER SPRING	RESSORT NIVELEUR	FEDER NIVELLIEREINHEIT	MUELLE NIVELADORA
16	G17916090	LAMA LIVELLATRICE LATERALE	SIDE LEVELLER BLADE	LAME NIVELEUR LATERAL	SEITLICHER MESSER NIVELLIEREIN	CUCHILLA NIVELADORA LATERAL
17	G17916140	TUBO Q. 50X 4X 800	PIPE 50X50X 4X 800	TUBE 50X50X 4X 800	ROHR 50X50X 4X 800	TUBO 50X50X 4X 800
18	G17916100	LAMA LIVELLATRICE LAT.430	SIDE LEVELLER BLADE	LAME NIVELEUR LATERAL	SEITLICHER MESSER NIVELLIEREIN	CUCHILLA NIVELADORA LATERAL
19	G13812311	CATENELLA CON MOSCHETTONE	CHAIN WITH SPRING CATCH	CHAINETTE AVEC MOUSQUETON	KETTE MIT KARABINERHAKEN	CADENA CON GANCHO

FUNZIONAMENTO:
 Con bobina diseccitata la valvola agisce da unidirezionale impedendo il flusso da A verso B e consentendolo in senso opposto.
 Eccitando la bobina l'otturatore si solleva consentendo il flusso in entrambe le direzioni.

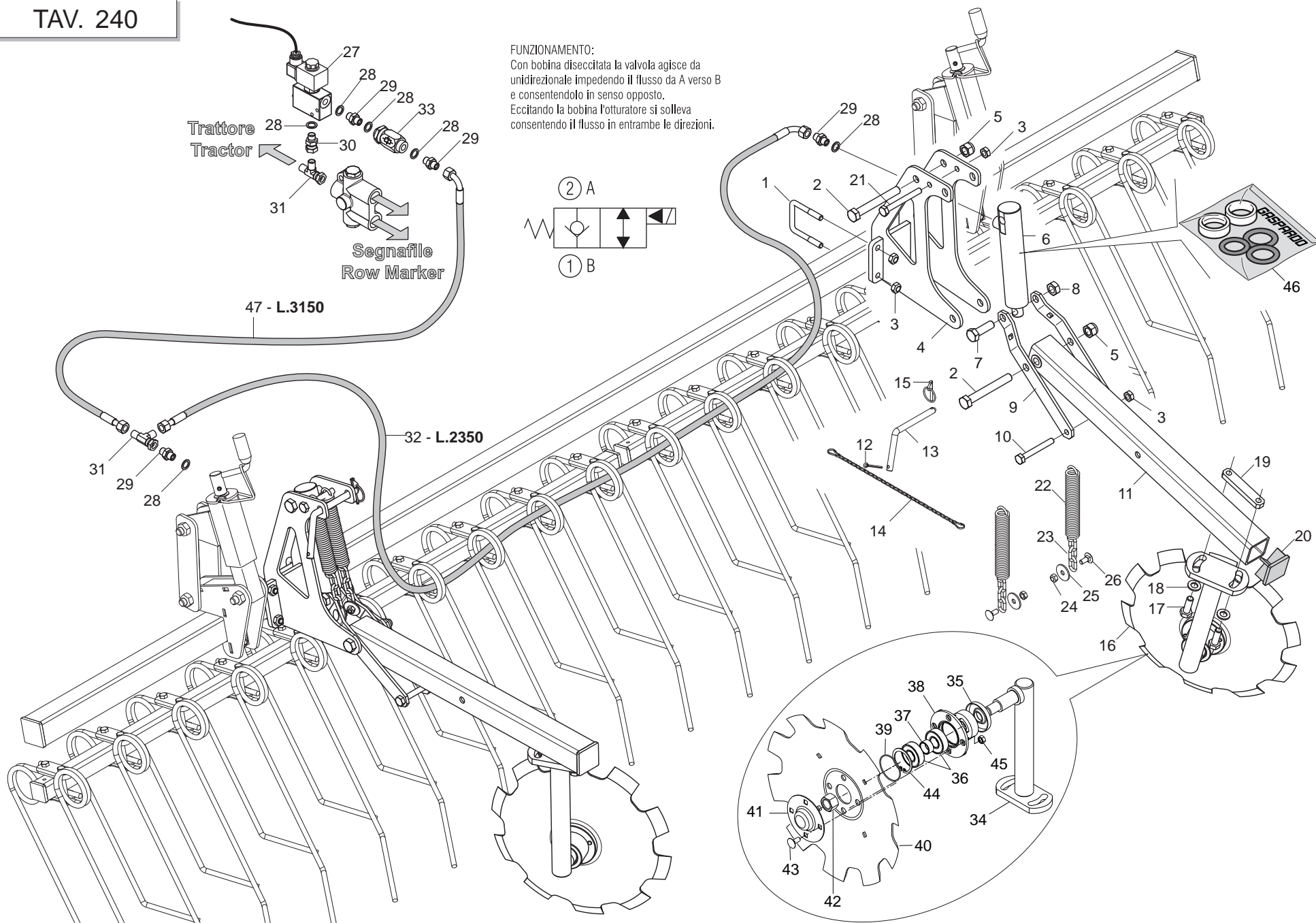
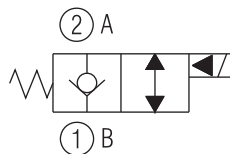

TRACCIASSENTIERI POSTERIORE

TAV. 240

Pos.	Cod.	Descrizione	Description	Description	Benennung	Descripcion
1	F20110715	CAV.Q.M10X 1,5X 30 61X 80 ZN				
2	F01020214	VITE M14X 2X100 U5737 8.8 ZN	BOLT 14X100 5737 8.G GALVANIZ.	VIS 14X100 5737 8.G ZN	SCHRAUBE 14X100 5737 8.G ZN	TORNILLO 14X100 5737 8.G ZN
3	F01220033	DADO M10X 1,5 D980 8 ZN	NUT M10X 1,5 D980 8 ZN	ECROU M10X 1,5 D980 8 ZN	MUTTER M10X 1,5 D980 8 ZN	TUERCA M10X 1,5 D980 8 ZN
4	G16070940	SUPPORTO TRACCIASSENTIERI	SUPPORT	SUPPORT	HALTERUNG	SOPORTE
5	F01230072	DADO M14X1,5 D982 6.6 ZN	SELF LOCKING NUT M14X1,5	ECROU AUTOBL. M14X1,5	SELBSTSP.MUTT.M14X1,5	DADO AUTOBL. M14X1,5
6	G16910360	CILINDRO SE 25X35-100	CYLINDER SE 25X35-100	CYLINDRE SE 25X35-100	ZYLINDER SE 25X35-100	CILINDRO SE 25X35-100
7	F01020198	VITE M14X 2X 45 U5737 8.8 ZN	BOLT 14X45 5737 8.G GALVANIZ.	VIS 14X45 5737 8.G ZN *	SCHRAUBE 14X45 5737 8.G ZN *	TORNILLO 14X45 5737 8.G ZN *
8	F01220255	DADO M14X 2 D980 8 ZN	NUT- TRISTOP M14X2 D980 8 ZN	ECROU TRISTOP M14X2 D980 8 ZN	MUTTER TRISTOP M14X2 D980 8 ZN	TUERCA TRISTOP M14X2 D980 8 ZN
9	G16070930	LEVA SOLLEVAMENTO	LIFTING LEVER	LEVIER LEVAGE	HEBEL HEBUNG	PALANCA LEVANTAMIENTO
10	F01020128	VITE M10X 1,5X80 U5737 8.8 ZN				
11	G16070850	BRACCIO SUPPORTO DISCO	DISK ARM	BRAS DISQUE	SCHEIBENARM	BRAZO DISCO
12	F02200227	COPIGLIA 5X 30 U1336 ZN	SPLIT PIN 5 X30 1336 GALVAN.	GOUPILLE 5 X30 1336 ZN	SPLINT 5 X30 1336 ZN	PASADOR 5 X30 1336 ZN
13	G22280025	CHIAVISTELLO PUNTELLO ID	PROP LATCH ID	VERROU ETRESILLON ID	RIEGEL STSTZE ID	PESTILLO PUNTAL ID
14	G13812311	CATENELLA CON MOSCHETTONE	CHAIN WITH SPRING CATCH	CHAINETTE AVEC MOUSQUETON	KETTE MIT KARABINERHAKEN	CADENA CON GANCHO
15	F02200452	SPINA SCATTO D.4,4 B/80 ZN	SNAP PIN D4,4 B/80 ZN	FICHE A DETENTE D4,4 B/80 ZN	EINRASTSTIFT D4,4 B/80 ZN	CLAVIJA DE MUELLE D4,4 B/80 ZN
16	G15317292	MONT.DISCO SEGNAFILE				
17	F01020512	VITE M12X1,75X35 U5739 8.8 ZN	SCREW M12X1,75X35 5739 8.8 ZN	VIS M12X1,75X35 5739 8.8 ZN	SCHR. M12X1,75X35 5739 8.8 ZN	TORN. M12X1,75X35 5739 8.8 ZN
18	F01410076	ROS.M12 13X 24X2,5 U6592 ZN	PLANE WASHER D12 UNI 6592 ZN	RONDELLE D12 UNI 6592 ZN	SCHEIBE D12 UNI 6592 ZN	ARANDELA D12 UNI 6592 ZN
19	G16070920	SCONTRIO 100X20 -10 2M12 80	STRIKER PLATE 100X20 -10 2M12	BUTEE 100X20 -10 2M12 80	ANSCHLAG 100X20 -10 2M12 80	ELEMENTO DE EMPALME 100X20
20	F20120349	PUNTALE Q.50 ALETT.POLIT.NERO				
21	F01020130	VITE M10X 1,5X90 U5737 8.8 ZN	BOLT M 10X90	VIS M 10X90	SCHRAUBE M 10X90	TORNILLO M 10X90
22	G18903540	MOLLA TRAZIONE SCARPETTE	PLANTER SHOE TRACTION SPRING	RESSORT TRACTION SABOTS	ZUGFEDER SZSCHAREN	MUELLE TRACCIN GUA APOYO AR
23	G16041240	CATENA GENOVESE D.5 L.79 ZN	GENOAN CHAIN D.5 L.79 ZN	CHAINE GENOISE D.5 L.79 ZN	KETTE GENOVESE D.5 L.79 ZN	CADENA GENOVESA D.5 L.79 ZN
24	F01220022	DADO M 8X1,25 D980 8 ZN	NUT M8X 1,25 D980 8 ZN	ECROU M8X 1,25 D980 8 ZN	MUTTER M8X 1,25 D980 8 ZN	TUERCA M8X 1,25 D980 8 ZN
25	F01420048	ROS.M8 8,4X 24X 2 U6593 ZN	PLANE WASHER D.8	RONDELLE D.8	SCHEIBE D.8	ARANDELA D.8
26	F01060040	BUL.M 8X1,25X 20 U5732 4.6 ZG	BOLT 8 X20 5732 4.6 GALVANIZED	VIS 8 X20 5732 4.6 ZN	SCHRAUBE 8 X20 5732 4.6 ZN	TORNILLO 8 X20 5732 4.6 ZN
27	G16070900	VALVOLA CABLATATA	VALVE	SOUPAPE	VENTIL	VALVULA
28	F01500012	RONDELLA IN RAME 1/4"	WASHER	RONDELLE	SCHEIBE	ARANDELA
29	F03150266	NIPPLO MM CIL-CIL 1/4-1/4 ZN	NIPPLE GALV.CYL.MALE 1/4 ZN	NIPPLE MALE CYL. 1/4 ZN	NIPPELZYL.1/4 ZN	NIPLE MACHO CIL.1/4 ZN
30	F03150045	NIPPLO MF GIREVOLE 1/4 ZN CIL	NIPPLE MF GIREVOLE 1/4 ZN CIL.	NIPPLE MF GIREVOLE 1/4 ZN CIL.	NIPPEL MF GIREV. 1/4 ZN. CIL	NIPLE MF GIREVOLE 1/4 ZN CIL.
31	F03151217	RACCORDO -T- LATER.M-M-FG 1/4	T M-FG-M + CONNECTION PIPE	RACCORD T M-FG-M 1/4	ANSCHLUSST M-FG-M 1/4	UNION T M-HG-M 1/4
32	G22505140	TUBO 1/4R2 C-F 1/4 L.2350 LM	PIPE 1/4R1 C-F 1/4 L.2350 LM	TUBE 1/4R1 C-F 1/4 L. 2350 LM	ROHR 1/4R1 C-F 1/4 L.2350 LM	TUBO 1/4R1 C-F 1/4 L.2350 LM
33	F03151226	REGOL.DI FLUSSO VRF 1/4' GAS	1/4' GAS VALVE VRF	SOUPAPE REG DEBIT VRF 1/4" GAZ	VENITL VRF 1/4' GAS	VæLVULA VRF 1/4' GAS
34	G15317283	ASS.SUPPORTO DISCO SEGNAFILE				
35	G16610430	FONDELLO ZN.				
36	F04010156	CUSC.d20 D47 B14 6204 2RSH				
37	G18801270	BOCCOLA 21 X25 X12 ZN	BUSHING 21 X 25 X 12 ZN	BOITE 21 X25 X12 ZN	BsCHSE 21 X25 X12 ZN	CASQUILLO 21 X25 X12 ZN
38	G16610160	SUPP.CUSCINETTI DISCO SEGN.ZN.	GALVAN. ROWMAKER DISK BEARING	SUPPORT ROULEMENTS DISQUE TRAC	SCHEIBENLAGERHALTERUNG	SOPORTE COJINETE DE DISCO MARC
39	F03010576	ANELLO OR 50,52X1,78 NBR	GASKET OR 033 DOWTY	BAGUE OR 033 DOWTY	RING OR 033 DOWTY	ANILLO OR 033 DOWTY
40	G16072590	DISCO SEGNAFILE D.350	ROW MARKER DISK D.350	DISQUE TRACEUR D350	SPURREISSERSCHEIBE D. 350	DISCO MARCARDOR DE FILAS O 350
41	G16610190	CHIUSURA CUSCINETTO ZN	GALVAN. BEARING CLOSURE	FERMETURE ROULEMENT ZN	LAGERVERSCHLUSS ZN	CIERRE COJINETE ZN
42	F01230098	DADO M18X 2,5 D982 8 ZN	NUT M18X 2,5 D982 8 ZN	ECROU M18X 2,5 D982 8 ZN	MUTTER M18X 2,5 D982 8 ZN	TUERCA M18X 2,5 D982 8 ZN
43	F01060040	BUL.M 8X1,25X 20 U5732 4.6 ZG	BOLT 8 X20 5732 4.6 GALVANIZED	VIS 8 X20 5732 4.6 ZN	SCHRAUBE 8 X20 5732 4.6 ZN	TORNILLO 8 X20 5732 4.6 ZN
44	F02050370	ANELLO E. DI 47X1,75 U7437 C70	SEEGER RING 47X 1,75 U7437 C70	SEEGER E. 47X 1,75 U7437 C70	SEEGERING E. 47X1,75 U7437 C70	ANILLO E. 47X 1,75 U7437 C70
45	F01200244	DADO M 8X1,25 U5588 6.8 ZN	NUT M8	ECROU M8	MUTTER M8	DADO M8
46	F03100200	KIT GUARNIZ.CILINDRO 16910360	16910360 CYLINDER GASKETS	JOINTS CYLINDRE 16910360	DICHTUNG ZYLINDER 16910360	PROTECCIONES CILINDRO 16910360
47	G15210950	TUBO 1/4 R2 C-F 1/4 L.3150	PIPE 1/4-R2 C-F 1/4 M.3150	TUBE 1/4-R2 C-F 1/4 M.3150	ROHR 1/4-R2 C-F 1/4 M.3150	TUBO 1/4-R2 C-F 1/4 M.3150



TABELLE INGOMBRO E LUCI
TAV. 250

Pos.	Cod.	Descrizione	Description	Description	Benennung	Descripcion
1	G17917040	ASS.SUPPORTO FANALI				
2	G16715250	SUPPORTO TABELLA				
3	F01220022	DADO M 8X1,25 D980 8 ZN	NUT M8X 1,25 D980 8 ZN	ECROU M8X 1,25 D980 8 ZN	MUTTER M8X 1,25 D980 8 ZN	TUERCA M8X 1,25 D980 8 ZN
4	F01220033	DADO M10X 1,5 D980 8 ZN	NUT M10X 1,5 D980 8 ZN	ECROU M10X 1,5 D980 8 ZN	MUTTER M10X 1,5 D980 8 ZN	TUERCA M10X 1,5 D980 8 ZN
5	F01020436	VITE M 8X1,25X 20 U5739 8.8 ZN	SCREW M8X1,25X20 U5739 8.8 ZN	VIS M8X1,25X20 U5739 8.8 ZN	SCHRA. M8X1,25X20 U5739 8.8 ZN	TORN. M8X1,25X20 U5739 8.8 ZN
6	F01410051	ROS.M8 8,4X 17X1,6 U6592 ZN	WASHER M8 8,4X17X1,6 U6592 ZN	RONDEL. M8 8,4X17X1,6 U6592 ZN	SCHEIBE M8 8,4X17X1,6 U6592 ZN	ARANDELA M8 8,4X17X1,6 U6592ZN
7	F20110715	CAV.Q.M10X 1,5X 30 61X 80 ZN				
8	F05010357	N.2 PANNELLI CARICHI SPORGENTI	N.2 JUTTING LOAD PANELS	N.2 PANNEAUX CHARGES SAILLANT	N.2 TAFELN VORSRINGENDE LADUN	2 PANELES CARGADOS SALIENTES
9	F06220010	VOLANTINO 4 LOBI M12X25	8-LOBE HANDWHEEL M12X25	VOLANT 8 LOBES M12X25	HANDRAD 8 BUCKEL M12X25	VOLANTE 8 LOBI M12X25
10	G67008050	TERMINALE ROTONDO 28	ROUND END 28	PIECE TERMIN.RONDE 28	RUNDER ABSCHLUSS 28	TERMINAL REDONDO 28
11	G17912000	KIT LUCI EUROTRIS COMPL				
12	F05010080	CABLAGGIO PER KIT LUCI	LIGHT WIRING HARNESS	CABLAGE KIT PHARES	VERKABELUNG LAMPENKIT	CABLEADO JUEGO LUCES
13	F05010076	FANALE X KIT LUCI	LAMP KIT LIGHTS COMPL.	FEU KIT ECLAIRAGE COMPL.	LAMPEN KIT LICHT KOMPL.	FAROL SET LUCES COMPL.
14	F05010221	CATARIFRANGENTE TONDO D.80 >	D.80 ROUND REFLECTOR	CATADIOPTRE ROND D.80	RUNDER R_CKSTRAHLER D.80	PAPEL REFRACTARIO REDONDO D.80
15	F01220200	DADO M 5X 0,8 D980 8 ZN	NUT M5X 0,8 D980 8 ZN	ECROU M5X 0,8 D980 8 ZN	MUTTER M5X 0,8 D980 8 ZN	TUERCA M5X 0,8 D980 8 ZN

TAV. 260

 Codice - Code Descrizione - Description		Lunghezze Lengths		Classe - Size (A x B) 	Tipo - Type (*)		Forcelle - Yokes (**)				
		min.	max.				Z6 (1"3/8)	Z6 (1"3/4)	Z8 (32x38)	Z20 (1"3/4)	Z21 (1"3/8)
F08011711	CARD.B1 Z6-Z6 L700	700	1100	B1 (22 x 54)	A	A	G58161015	F08011772	F08011742	F08011758	F08011767
F08011712	CARD.B3 Z6-Z6 L1300	1300	2000	B3 (27 x 70)	A	A	—	G58161016	F08011743	—	—
F08011713	CARD.B1 Z8-Z6 L700	700	1100	B1 (22 x 54)	A	A	G58161015	F08011772	F08011742	F08011758	F08011767
F08011714	CARD.B1 Z20-Z6 L700	700	1100	B1 (22 x 54)	A	A	G58161015	F08011772	F08011742	F08011758	F08011767
F08011715	CARD.B1 Z8-Z6 L900 R.LIB	900	1400	B1 (22 x 54)	A	B	G58161015	F08011772	F08011742	F08011758	F08011767
F08011716	CARD.B1 Z6-Z6 L900 R.LIB	900	1400	B1 (22 x 54)	A	B	G58161015	F08011772	F08011742	F08011758	F08011767
F08011719	CARD.B2 Z6-Z6 L900	900	1400	B2 (23,8 x 61,3)	A	B	—	—	—	—	—
F08011720	CARD.B3 Z8-Z6 L1300	1300	2000	B3 (27 x 70)	A	A	—	G58161016	F08011743	—	—
F08011757	CARD.B1 Z20-Z6 L900 R.L	900	1400	B1 (22 x 54)	A	B	G58161015	F08011772	F08011742	F08011758	F08011767
F08011764	CARD.R4 Z20-Z6 L1210 OM-RL	1210		R4 (27 x 74,6)	A	C	F08011768	—	F08011766	F08011774	F08011773

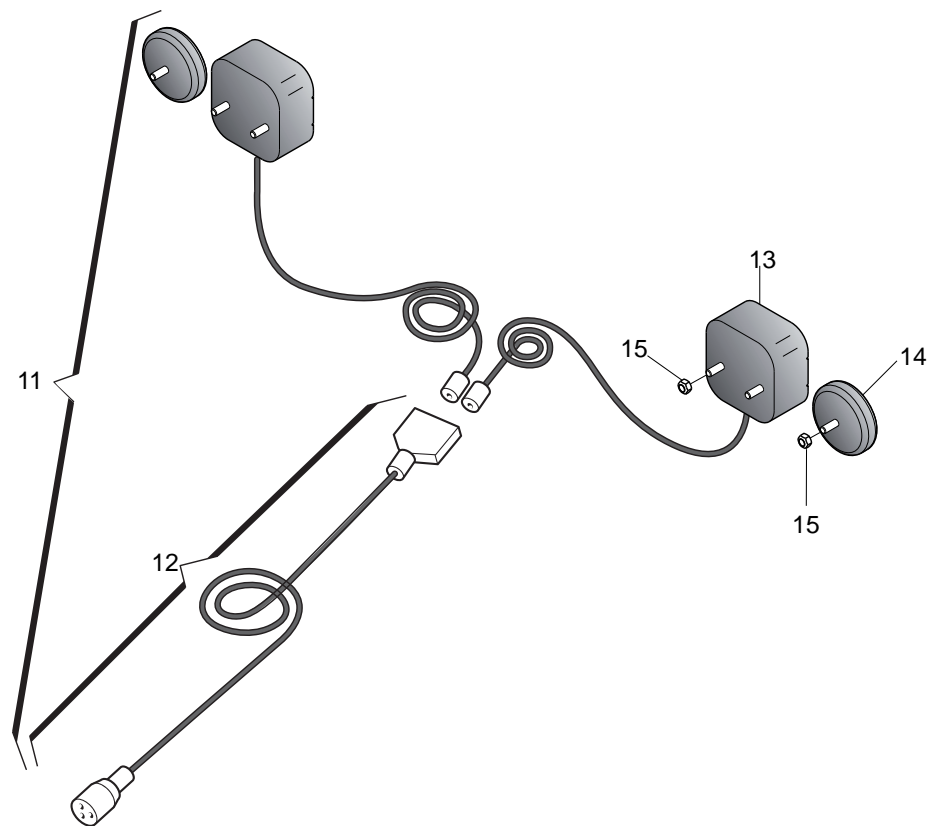
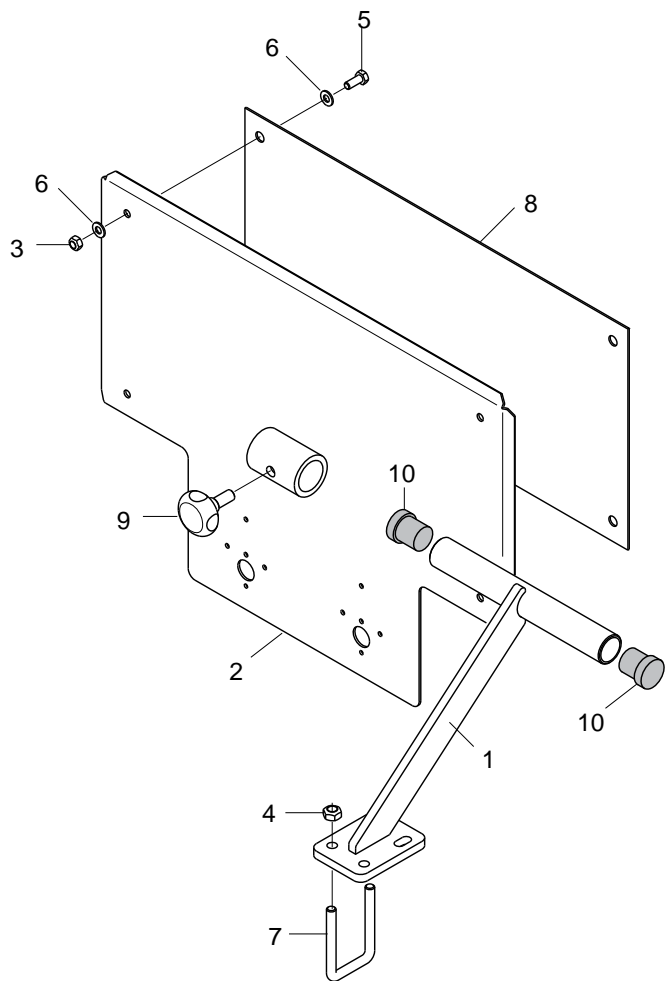
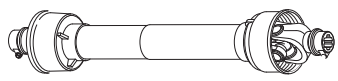
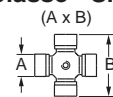
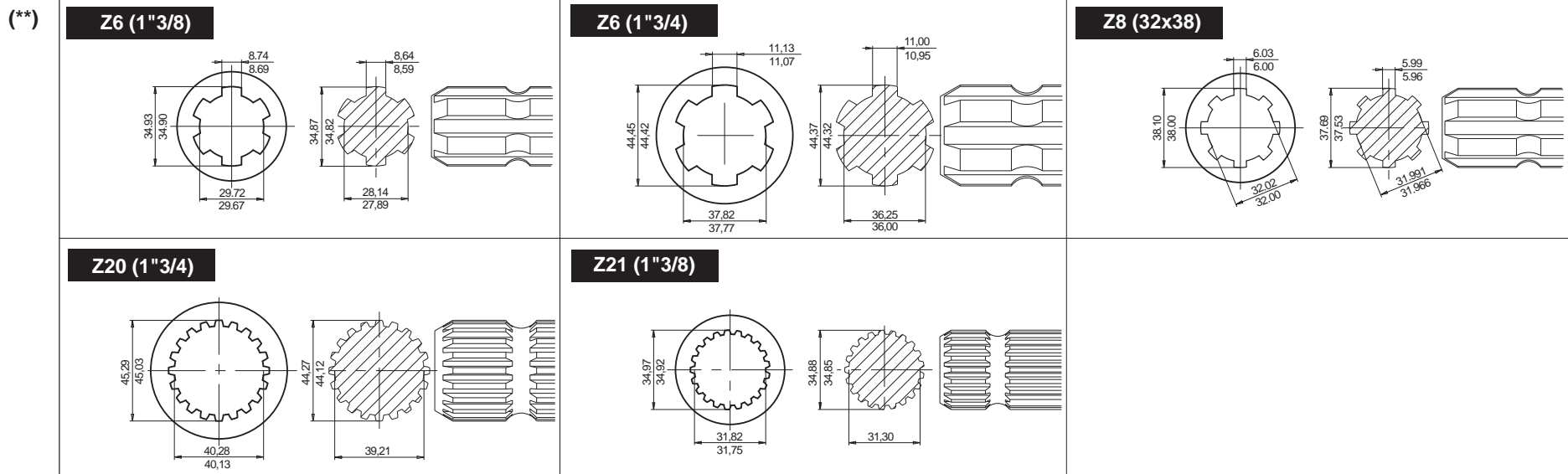
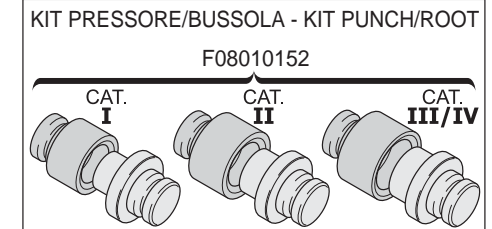
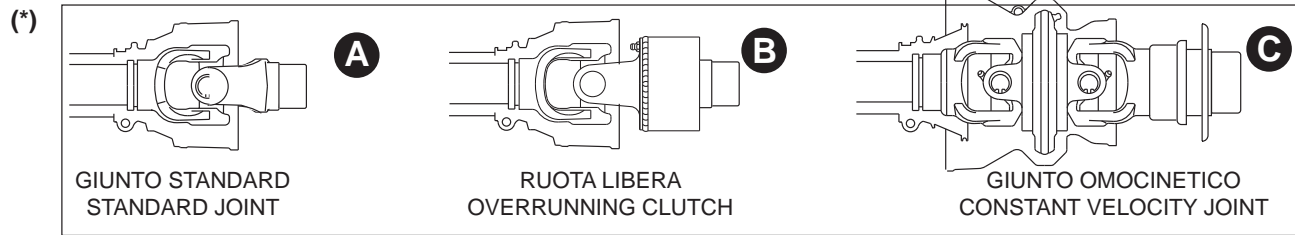

ALBERI CARDANICI

TAV. 260

Pos.	Cod.	Descrizione	Description	Description	Benennung	Descripcion
	F08010152	KIT PRESSORE BUSSOLA CAT I-IV>	TOOLS FOR PTO YOKE CAT I-IV			
	F08011711	CARD.B1 Z6-Z6 L700	CARD.B1 Z6-Z6 L700	CARD.B1 Z6-Z6 L700	KARD.B1 Z6-Z6 L700	CARD.B1 Z6-Z6 L700
	F08011712	CARD.B3 Z6-Z6 L1300	UNIVERSAL JOINT T40 1020F 112	CARD. T40 1020F 112 112 1 CAT	KARDAN T40 1020F 112 112 1CAT	CARDæN T40 1020F 112 112 1CAT
	F08011713	CARD.B1 Z8-Z6 L700	UNIV.JOINT B1070BA32A60 Z-8 Z-	CARD. B1070BA32A60 Z-8 Z-6	KARDAN B1070BA32A60 Z-8 Z-6	CARD+N B1070BA32A60 Z-8 Z-6
	F08011714	CARD.B1 Z20-Z6 L700				
	F08011715	CARD.B1 Z8-Z6 L900 R.LIB				
	F08011716	CARD.B1 Z6-Z6 L900 R.LIB	UNIV.JOINT CE T100710 112 R12	CARD ROUE LIBRE T100710 112R12	KARDAN CE T100710 112 R12	CARDAN CE T100710 112 R12
	F08011719	CARD.B2 Z6-Z6 L900	UNIVERSAL JOINT 102 071 N T07	CARD. 102 071 N T07 T07 1 CAT	KARDAN 102 071 N T07 T07 1CAT	CARDæN 102 071 N T07 T07 1CAT
	F08011720	CARD.B3 Z8-Z6 L1300				
	F08011742	FORCELLA CARD.32X38 Z8 B1	PTO YOKE Z8 B1	FOURCHETTE CARDAN Z8 B1	GABEL KARDAN Z8 B1	HORQUILLA CARDAN Z8 B1
	F08011743	FORCELLA CARD.32X38 Z8 B3	YOKE CARD.32X38 Z8 B3			
	F08011757	CARD.B1 Z20-Z6 L900 R.L >				
	F08011758	FORCELLA CARD.1"3/4 Z20 B1 >				
	F08011764	CARDANO OM 3/4Z20-RL Z6 L1381				
	F08011766	FORCELLA CARD.32X38 Z8 R4				
	F08011767	FORCELLA CARD.1 3/8 Z21 B1 >				
	F08011768	FORCELLA CARD.1 3/8 Z6 R4				
	F08011772	FORCELLA CARD.1"3/4 Z6 B1 >				
	F08011773	FORCELLA CARD.1 3/8 Z21 R4 >				
	F08011774	FORCELLA CARD.1 3/4 Z20 R4				
	G58161015	FORCELLA CARD.1'3/8 Z6 B1				
	G58161016	FORCELLA CARD.1'3/8 Z6 B3 >				

**USATE SEMPRE RICAMBI ORIGINALI
ALWAYS USE ORIGINAL SPARE PARTS
IMMER DIE ORIGINAL-ERSATZTEILE VERWENDEN
EMPLOYEZ TOUJOURS LES PIECES DE RECHANGE ORIGINALES
UTILIZAR SIEMPRE REPUESTOS ORIGINALES**

GASPARDO

**Servizio Assistenza Tecnica - After Sales Service
Servizio Ricambi - Spare Parts Service
+39 0434 695410**

DEALER:



GASPARDO

G19531020



MASCHIO GASPARDO SpA
Sede legale e stabilimento produttivo
Via Marcello, 73 - 35011 Campodarsego (Padova) - Italy
Tel. +39 049 9289810
Fax +39 049 9289900
Email: info@maschio.com
www.maschionet.com

MASCHIO GASPARDO SpA
Stabilimento produttivo
Via Mussons, 7 - 33075
Morsano al Tagliamento (PN) - Italy
Tel. +39 0434 695410
Fax +39 0434 695425
Email: info@gaspardo.it

MASCHIO DEUTSCHLAND GMBH
Äußere Nürnberger Straße 5
D - 91177 Thalmässing
Deutschland
Tel. +49 (0) 9173 79000
Fax +49 (0) 9173 790079

MASCHIO FRANCE Sarl
1, Rue de Mérignan ZA
F - 45240 La Ferte St. Aubin
France
Tel. +33 (0) 2.38.64.12.12
Fax +33 (0) 2.38.64.66.79

MASCHIO IBERICA S.L.
Calle Cabernet, 10
Polígono Industrial Clot de Moja
Olerdola - 08734 Barcelona
Tel. +34 93.81.99.058
Fax +34 93.81.99.059

MASCHIO-GASPARDO USA Inc
120 North Scott Park Road
Eldridge, IA 52748 - USA
Ph. +1 563 2859937
Fax +1 563 2859938
e-mail: info@maschio.us

ООО МАСКИО-ГАСПАРДО РУССИЯ
Улица Пушкина, 117 Б
404126 Волжский
Волгоградская область
Тел. +7 8443 525065
факс. +7 8443 525064

MASCHIO-GASPARDO ROMANIA S.R.L.
Strada Înfrâtitirii, F.N.
315100 Chisineu-Cris (Arad) - România
Tel. +40 257 307030
Fax +40 257 307040
e-mail: maschio@maschio.ro

MASCHIO MIDDLEEAST
P.O. Box 922388
Amman, 11192 Jordan
Tel. 962 605511384
Fax 962 6 5538398
e-mail: tahaeng@nets.com.jo

GASPARDO-MASCHIO TURCHIA
MASCHIO-GASPARDO CANADA Inc
MASCHIO-GASPARDO CINA
MASCHIO-GASPARDO POLAND
MASCHIO-GASPARDO UCRAINA
GASPARDO BIELORUSSIA
MASCHIO-GASPARDO KOREA