

MASCHIO GASPARDO S.p.A.

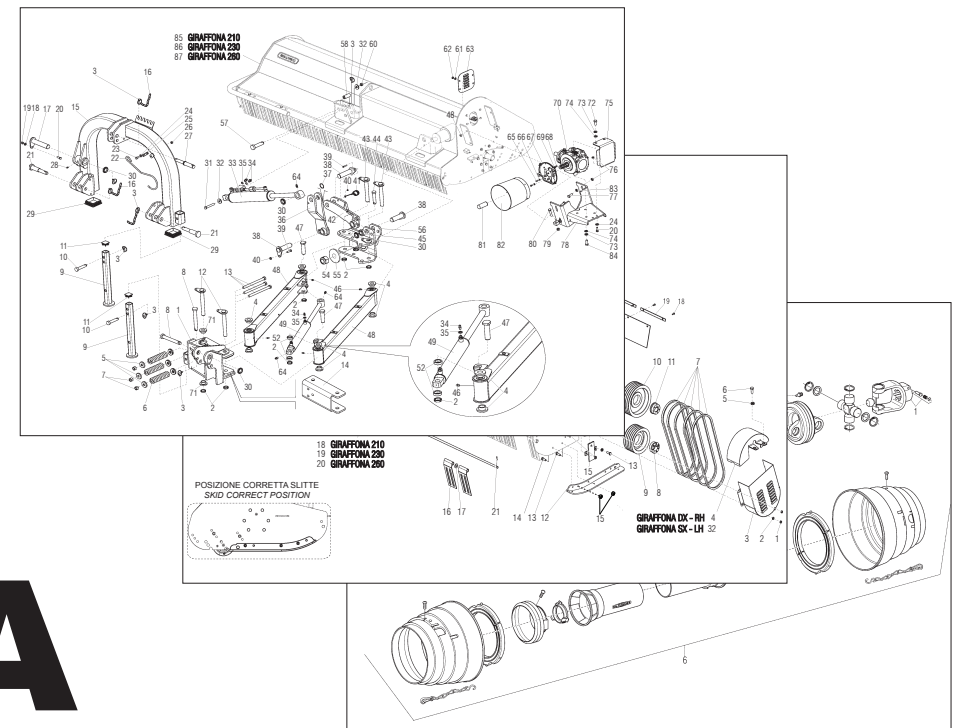

GIRAFFONA

Cod: F07011300 2015-01

- *) Valido per Paesi UE
- *) Valid for EU member countries
- *) Valable dans les Pays UE
- *) Gilt für EU-Mitgliedsländer
- *) Válido para Países UE

- IT** PARTI DI RICAMBIO
- EN** SPARE PARTS
- DE** ERSATZTEILE
- FR** PIÈCES DÉTACHÉES
- ES** PIEZAS DE REPUESTO

ITALIANO	ENGLISH	DEUTSCH	FRANÇAIS	ESPAÑOL
PARTI DI RICAMBIO	SPARE PARTS	ERSATZTEILE	PIECES DÉTACHÉES	RESPUESTOS
<p>Le ordinazioni delle parti di ricambio vanno fatte presso i nostri concessionari di zona e devono essere sempre corredate dalle seguenti indicazioni:</p> <ul style="list-style-type: none"> - Tipo, modello e numero di matricola dell'attrezzatura. Tali dati sono stampigliati nell'apposita targhetta di cui è dotata ogni attrezzatura. - Numero di codice della parte richiesta rilevabile dal catalogo ricambi. - Descrizione del particolare e quantità richiesta. - Numero della tavola. - Mezzo di trasporto. Nel caso questa voce non sia specificata, la Ditta Costruttrice, pur dedicando a questo servizio una particolare cura, non risponde di eventuali ritardi di spedizione dovuti a cause di forza maggiore. Le spese di trasporto si intendono sempre a carico del destinatario. La merce viaggia a rischio e pericolo del committente anche se venduta franco destino. <p>NOTA: Il termine (Dx) Destro o (Sx) Sinistro della macchina o di parti di essa, è inteso guardando la macchina dalla parte posteriore. Le eccezioni saranno indicate.</p>	<p><i>Orders must be transmitted through our area dealers and should always include the following indications:</i></p> <ul style="list-style-type: none"> - Type, model and serial number of the machine. <i>These data are punched on the data plate with which every implement is equipped.</i> - Code number of the required spare part. <i>This will be found in the spare parts catalogue.</i> - Description of the part and required quantity. - Table number. - Means of dispatch. <i>If this item is not indicated, the Manufacturer, while dedicating particular care to this service, shall not be held responsible for delays in delivery caused by cases of force majeure. Transport expenses shall always be at the consignee's charge. The goods travel at the purchaser's risk and peril even when sold ex destination.</i> <p>NOTE: <i>The symbols (Dx) right and (Sx) left, concerning the machine or single parts of it, are referred, as in the figure, to a rear view of them. Exceptions will be indicated.</i></p>	<p>Die Bestellungen müssen bei unseren Gebietshändlern aufgegeben werden. Bei der Bestellung sind stets die folgenden Angaben zu machen:</p> <ul style="list-style-type: none"> - Typ, Modell und Serien-Nummer des Geräts. Diese Daten stehen auf dem Typenschild, mit dem jedes Gerät versehen ist. - Artikel Nr. der erforderlichen Ersatzteile. Diese stehen im Ersatzteil-Katalog. - Beschreibung des Ersatzteils und die erforderliche Stückzahl. - Tafelnummer. - Versandmittel. Wenn dieser Punkt nicht spezifiziert wird, haftet die Herstellerfirma nicht für etwaigen Lieferverzug aufgrund höherer Gewalt, auch wenn er diesen Service besonders aufmerksam abwickelt. Die Frachtkosten gehen dagegen immer zu Lasten des Empfängers. Die Ware reist auf Gefahr und Risiko des Auftraggebers, auch wenn frei Haus Verkauft vereinbart worden ist. <p>N.B.: Die Merkzeichen (Dx) rechts und (Sx) links betreffen eine rückwärtige Aussicht der Maschine oder Teile von ihr (siehe Bild). Ausnahmen werden gezeigt.</p>	<p><i>Les ordres doivent être effectués auprès de nos concessionaires de zone en précisant les indications suivantes:</i></p> <ul style="list-style-type: none"> - Type, modèle et numéro de série de la machine. <i>Ces données sont gravées sur la plaque d'identification de chaque outil.</i> - Numéro de code de la pièce détachée indiqué sur le catalogue des pièces détachées. - Description de la pièce et quantité requise. - Numéro de plan. - Moyen d'expédition. <i>Si cette rubrique n'est pas indiquée, le Constructeur, bien que soucieux de ce service, ne répond pas des retards d'expédition pour des causes de force majeure. Les frais de transport sont toujours à la charge du destinataire. La marchandise voyage aux risques et périls de l'acheteur même si vendue franco de port.</i> <p>N.B.: <i>Les références (Dx) droit et (Sx) gauche de la machine ou des parties de la même, est entendue, comme de la figure, en regardant la machine de derriere dans le sens de marche.</i></p>	<p>Los pedidos han de efectuarse en nuestros concesionarios de zona y deben incluir siempre las siguientes indicaciones:</p> <ul style="list-style-type: none"> - Tipo, modelo y número de matrícula del equipo. Dichos datos están impresos en la relativa placa presente en el equipo. - Número de código de la parte requerida presente en el catálogo respuestas. - Descripción de la pieza y cantidad requerida. - Numero de ilustración. - Medio de transporte. En caso que este ítem no esté especificado, el Fabricante, aún prestando la debidas consideraciones para este aspecto, no responde por eventuales retardos de env'o debidos a causas de fuerza mayor. Los gastos de transporte se consideran siempre a cargo del destinatario. La mercadería viaja bajo riesgo y peligro del comprador, incluso cuando se vende franco destino. <p>N.B.: La referencia (Dx) derecha o (Sx) izquierda de la máquina o de sus componentes, se entiende, como en la figura, mirando la máquina por la parte trasera. Se indicarán las excepciones.</p>

INDICE

<i>N° Tavola</i>	<i>Descrizione</i>	<i>Pagina</i>
TAV. 010	Telaio destro e terzo punto.....	4
TAV. 020	Telaio sinistro e terzo punto	8
TAV. 030	Trasmissione.....	12
TAV. 040	Rullo.....	14
TAV. 050	Rotore	16
TAV. 060	Moltiplicatore 540 rpm - Bondioli per versione destra.....	18
TAV. 070	Moltiplicatore 540 rpm - Bondioli per versione sinistra	20
TAV. 080	Impianto idraulico.....	22
TAV. 090	Accessori optional.....	24
TAV. 100	Rotore speciale (optional).....	26
TAV. 110	Cardano omocinetico Walterscheid	28

INDEX

<i>N° Table</i>	<i>Description</i>	<i>Page</i>
TAV. 010	Right frame and 3rd point hitch.....	4
TAV. 020	Left frame and 3rd point hitch	8
TAV. 030	Transmission.....	12
TAV. 040	Roller.....	14
TAV. 050	Rotor	16
TAV. 060	Gearbox 540 rpm - Bondioli for right version	18
TAV. 070	Gearbox 540 rpm - Bondioli for left version	20
TAV. 080	Hydraulic plant	22
TAV. 090	Optional fitting	24
TAV. 100	Special rotor (optional).....	26
TAV. 110	Walterscheid constant velocity PTO shaft.....	28

TAV. 010

- 85 GIRAFFONA 210
- 86 GIRAFFONA 230
- 87 GIRAFFONA 260

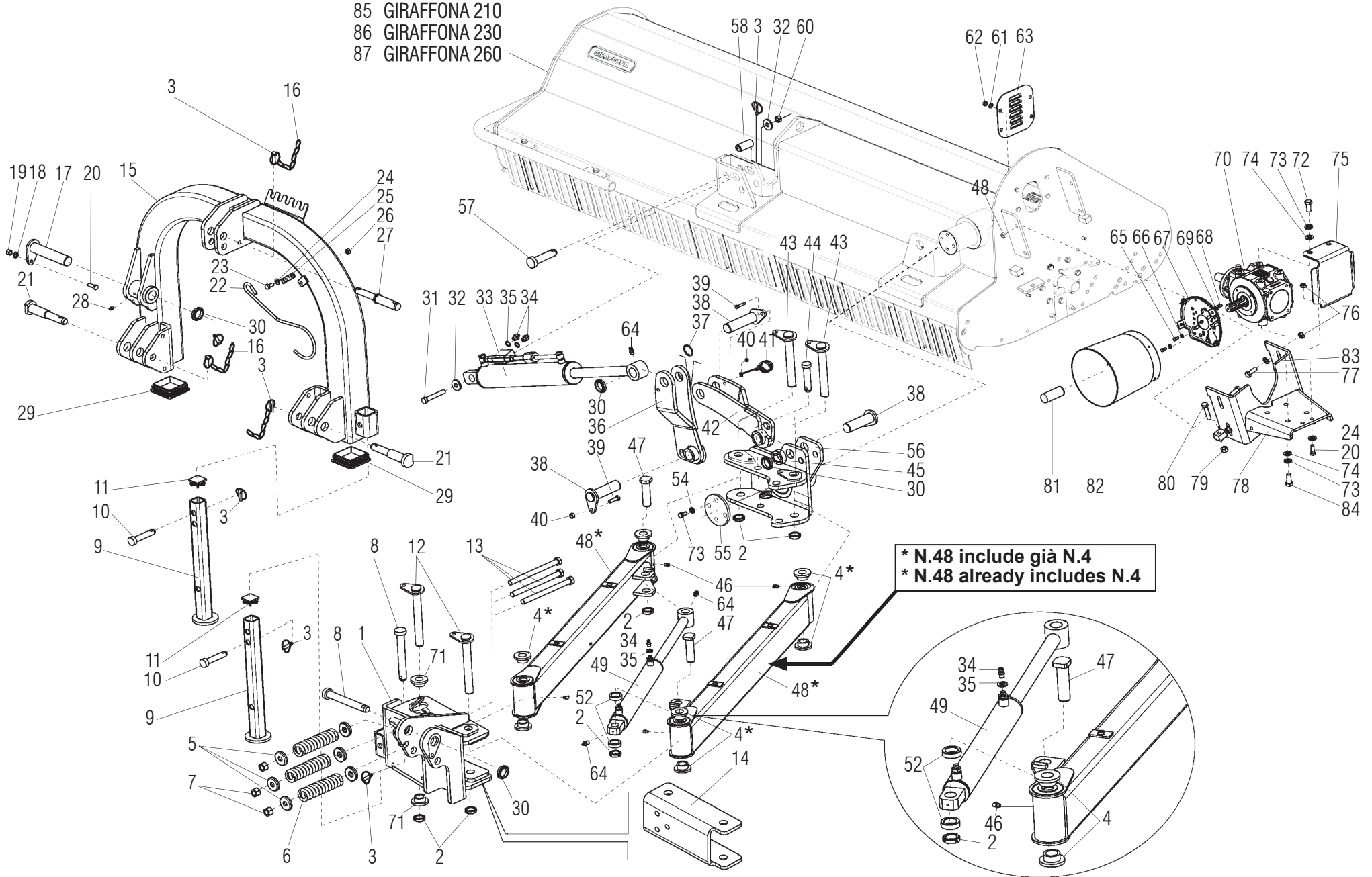

TELAIO DESTRO E TERZO PUNTO / RIGHT FRAME AND 3rd POINT HITCH

TAV. 010

Pos.	Cod.	Descrizione	Description	Benennung	Description	Description
1	M50400716	COMPOSTO ATTACCO 3° PUNTO	LINKAGE 3RD POINT	DREIPUNKTVERBINDUNG	ATTELAGE 3EME POINT	ATAQUE 3 PUNTO
2	F02010133	GHIERA AU.GUP M40X1,5 T.4H ZN	SELF LOCKING NUT M40X1,5	COLLIER AUTOBL.M40X1,5 T.4H ZN	SELBSTSP. NUTMUTTER M40X1,5	VIROLA AUTOBL. M40X1,5 T.4H ZN
3	F02200529	SPINA SCATTO D.11 ZN	SNAP PIN D.11	EINRASTSTIFT D.11	FICHE A DETENTE D.11	CLAVIJA DE MUELLE D.11
4	M07700545	BOCCOLA D=30 D=40 L=30	BUSHING D=30 D=40 L=30	BUECHSE D=30 D=40 L=30	BOUCLE D=30 D=40 L=30	ARANDELA D=30 D=40 L=30
5	G16610430	FONDELLO	BOTTOM	BODENSCHIEBE	CULOT	FONDO
6	M50400567	MOLLA	SPRING	FEDER	RESSORT	MUELLE
7	F01200136	DADO M20X 1,5 U5587 6S ZN	NUT M20X1,5	MUTTER M20X1,5	ECROU M20X1,5	DADO M20X1,5
8	F20100077	PERNO D=28 L=194 ZN	PIN D=28 L=200	STIFT D=28 L=200	GOUJON D=28 L=200	PERNO D=28 L=200
9	M12400590	PIEDINO L=550	SUPPORT	FRASE STANDER	SUPPORT FRAISE	SOPORTE FRESADORA
10	F20100049	PERNO D22 L86 C43 ZN	PIN D.22	BOLZEN D.22	GOUJON D.22	PERNO D.22
11	F20120349	PUNTALE Q.50 ALETT.POLIT.NERO	CAP	DECKEL	BOUCHON	CORCHO
12	M07700534	PERNO D=40 L=263	PIN D=30 L=263	STIFT D=30 L=263	GOUJON D=30 L=263	PERNO D=30 L=263
13	F01010181	VITE M20X1,5X250 U5738 8.8 ZN	BOLT M20X1,5X250	SCHRAUBE M20X1,5X250	VIS M20X1,5X250	TORNILLO M20X1,5X250
14	M07700528	PIASTRA ROTAZIONE	PLATE	PLATTE	PLAQUETTE	PLAQUITA
15	M50400523	CASTELLO 3° PUNTO	COMPLETE 3RD POINT	3. PUNKT KOMPLETT	3EME POINT COMPL.	TERCER PUNTO COMPL.
16	M63112581	ASSIEME CATENELLA L.333 ZN	CHAIN	KETTE	CHAINE	CADENA
17	M50400591	PERNO FLOTTANTE D=40 L=195	PIN D=40 L=195	PIN D=40 L=195	GOUJON D=40 L=195	PERNO D=40 L=195
18	F01480123	ROS.G 12,5X22,9X 4 EX.C70 ZN	WASHER M12 ZGP EXTRA P.	UNTERLEGSCHIEBE M12 ZGP EXTRA P.	RONDELLE M12 ZGP EXTRA P.	ARANDELA M12 ZGP EXTRA P.
19	F01200073	DADO M12X1,25 U5587 6S ZN	NUT M12X1,25 U5587 6S ZN	MUTTER M12X1,25	ECROU M12X1,25	TUERCA M12X1,25
20	F01010288	VITE M12X1,25X35 U5740 8.8 ZN	SCREW M12X1,25X35 U5740 8.8 ZN	SCHR.M12X1,25X35 U5740 8.8 ZN	VIS M12X1,25X35 U5740 8.8 ZN	TORN.M12X1,25X35 U5740 8.8 ZN
21	M21400563	PERNO ATTACCO BARRA.2°-3° C.	PIN FOR BAR LINKAGE	VERB.BOLZEN SCHUTZ HOLM	GOUJON ATTELAGE BARRE	PERNO ATAQUE BARRA
22	F20120400	GANCIO SOSTEGNO CARDANO	SHAFT HOOK	GELENKWELLE - HACKEN	SUPPORT CARDAN	SOPORTE CARDAN
23	F01010281	VITE M12X1,25X25 U5740 8.8 ZN	BOLT M 12X1,25X25	SCHRAUBE M 12X1,25X25	VIS M 12X1,25X25	TORNILLO M 12X1,25X25
24	F01410076	ROS.M12 13X 24X2,5 U6592 ZN	WASHER D12 U6592 ZN	SCHEIBE D12 U6592 ZN	RONDELLE D12 U6592 ZN	ARANDELA D12 U6592 ZN
25	F20120401	FASCETTA FERMA CARDANO ZN	LOCK	ARRET	BLOCKIERUNG	FAJA SEGURO DEL CARDÁN
26	F01220047	DADO M12X1,25 D980 8 ZN	NUT M12X1,25 D980 8 ZN	MUTTER M12X1,25 D980 8 ZN	ECROU M12X1,25 D980 8 ZN	TUERCA M12X1,25 D980 8 ZN
27	F20100130	PERNO ATTACCO TIRANTE	PIN	STIFT	GOUJON	PERNO
28	F01100061	ING.M10X1 7663-A 9SMNPB28 ZN	GREASE NIPPLE M10X1 7663-A ZN	SCHMIERBUECHSE M10X1 7663-A ZN	GRAISSEUR M10X1 7663-A ZN	ENGRASADOR M10X1 7663-A ZN
29	F05100163	TAPPO*PLT X TUBO	CAP	DECKEL	BOUCHON	CORCHO
30	F02010034	GHIERA AU.GUK M40X1,5 T.4H ZN	SELF LOCKING NUT	SELBSTSP. NUTMUTTER	COLLIER AUTOBL.	VIROLA AUTOBL.
31	F01010124	VIT.M16X 1,5X100 U5738 8.8 ZN	BOLT M16X1,5X100	SCHRAUBE M16X1,5X100	VIS M16X1,5X100	TORNILLO M16X1,5X100
32	F01500023	ROS. 17 X45X6 D6340 C50 ZD	ELASTIC DISK	ELASTISCHE SCHEIBE	DISQUE ELASTIQUE	DISCO ELASTICO
33	M50400545	COMP. MART.IDR.A=80 C=400 L712	JACK SCREW ASSY	SPINDELVERSTELLUNGSTEIL	VERIN	MARTINETE
34	F03150310	NIPPLO MM CIL-CIL 3/8-1/4 ZN	NIPPLE CYL.MALE3/8-1/4 ZN	NIPPELZYL 3/8-1/4 ZN	NIPPLE MALE CYL.3/8-1/4 ZN	NIPLE MACHO CIL.3/8-1/4 ZN
35	F03100023	ROS. 17 X23X1,5 RAME -3/8"	WASHER 17X 23X1,5 -3/8"	SCHEIBE 17X 23X1,5 RAME -3/8"	RONDELLE 17X 23X1,5 -3/8"	ARANDELA 17X 23X1,5 -3/8"
36	M50400560	COMPOSTO BIELLA	CONNECTING ROD	PLEUELSTANGE	BIELLE	BIELA
37	M48000307	ANELLO RINF.40X50X1,5 C70 TEMP	STIFFENER RING 40X50X1,5 C70	BAGUE DE RENFORCEM. 40X50X1,5	SEEGER RING 40X50X1,5 C70	ANILLO REFUERZO 40X50X1,5
38	M50400578	PERNO D=40 L=130	PIN D=40 L=130	STIFT D=40 L=130	GOUJON D=40 L=130	PERNO D=40 L=130
39	F01020450	VITE M 8X1,25X40 U5739 8.8 ZN	BOLT M 8X40	SCHRAUBE M 8X40	VIS M 8X40	TORNILLO M 8X40
40	F01220022	DADO M 8X1,25 D980 8 ZN	NUT M8X 1,25 D980 8 ZN	MUTTER M8X 1,25 D980 8 ZN	ECROU M8X 1,25 D980 8 ZN	TUERCA M8X 1,25 D980 8 ZN
41	M21100654	MOLLA PER TUBO SPANDICONC.	SPRING	FEDER	RESSORT	RESORTE
42	M50400562	PIATTO BIELLA	PLATE	PLATTE	PLAT	PLATO
43	M07700540	PERNO D=40 L=207	PIN D=30 L=207	STIFT D=30 L=207	GOUJON D=30 L=207	PERNO D=30 L=207
44	F20100063	PERNO D25 L91 C40 ZN	BOLT D25 L91 C40 ZN	BOLZEN D25 L91 C40 ZN	BOULON D25 L91 C40 ZN	PERNO D25 L91 C40 ZN
45	M09400578	DISTANZIALE D=60 D=40.5 L=22	SPACER	DISTANZSTUECK	ENTRETOISE	DISTANCIADOR

----- CONTINUA A PAGINA SEGUENTE -----
 ----- CONTINUED ON NEXT PAGE -----

TAV. 010

- 85 GIRAFFONA 210
- 86 GIRAFFONA 230
- 87 GIRAFFONA 260

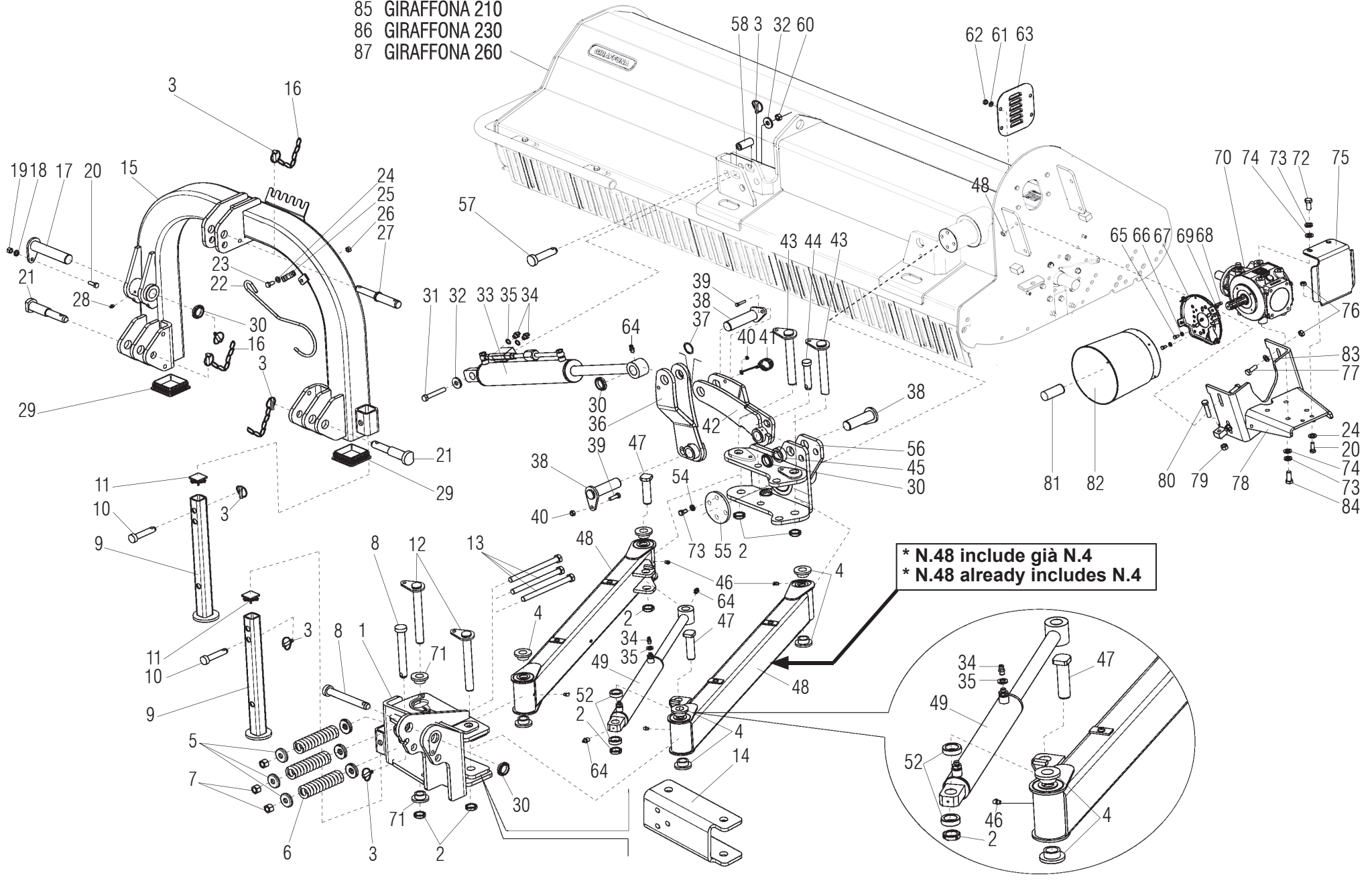

TELAIO DESTRO E TERZO PUNTO / RIGHT FRAME AND 3rd POINT HITCH

TAV. 010

Pos.	Cod.	Descrizione	Description	Benennung	Description	Description
<p>----- CONTINUA DA PAGINA PRECEDENTE ----- ----- CONTINUED FROM PRECEDING PAGE -----</p>						
46	F01100063	ING.M10X1 7663-C 9SMNPB28 ZN	GREASE NIPPLE M10X1	SCHMIERBUECHSE M10X1	GRAISSEUR M10X1	ENGRASADOR M10X1
47	M07700539	COMP.PERNO D=30 L=109	PIN D=30 L=109	STIFT D=30 L=109	GOUJON D=30 L=109	PERNO D=30 L=109
48	M07700529	PARALLELOGRAMMA GIRAFFONA	ARM	ARM	BRAS	BRAZO
49	M50400550	COMP. MART.IDR.A=60 C=380 L630	JACK SCREW ASSY	SPINDELVERSTELLUNGSTEIL	VERIN	MARTINETE
52	M23400528	ROSETTA D=48,3 D=32,5 L=15	WASHER D=48,3 D=32,5 L=15	SCHEIBE D=48,3 D=32,5 L=15	ROSETTE D=48,3 D=32,5 L=15	ARANDELLA D=48,3 D=32,5 L=15
54	F01480145	ROS.G 17X29 X 5 FLZNNC-240H	GROWER WASHER 17X29	RONDELLE GROWER 17X29	SCHEIBE GROWER 17X29	ARANDELA GROWER 17X29
55	M50400785	ROSETTA DI BLOCCAGGIO	PLANE WASHER	SCHEIBE	RONDELLE	ARANDELA
56	M50400718	GIUNTO MOVIMENTAZIONE	JOINT	VERBINDUNG	JOINT	JUNTA
57	F20100078	PERNO D28 L93 C43 ZN	PIN D.28	BOLZEN D.28	GOUJON D.28	PERNO D.28
58	M50400556	DISTANZIALE D=30 D=20 L=65	SPACER D=30 D=20 L=65	DISTANZST.D=30 D=20 L=65	ENTRETOISE D=30 D=30 L=65	DISTANCIAD.D=30 D=20 L=65
60	F01220070	DADO M16X 1,5 D980 8 ZN	NUT M16X 1,5 D980 8 ZB	MUTT.M16X 1,5 D980 8 ZB	ECRO.M16X 1,5 D980 8 ZB	TUER.M16X 1,5 D980 8 ZB
61	F01410064	ROS.M10 10,5X 20X 2 U6592 ZN	WASHER M10 10,5X20X2 U6592 ZN	SCHEIBE M10 10,5X20X2 U6592 ZN	RONDELL.M10 10,5X20X2 U6592 ZN	ARAND. M10 10,5X20X2 U6592 ZN
62	F01220034	DADO M10X1,25 D980 8 ZN	NUT M10X1,25 D980 8 ZB	MUTT.M10X1,25 D980 8 ZB	ECRO.M10X1,25 D980 8 ZB	TUER.M10X1,25 D980 8 ZB
63	M07400939	CARTER FIANCATA	CARTER	GEHAEUSE	CARTER	CARTER
64	F01100011	INGRAS.A SFERA M6X1 DRITTO A	SPHERE NIPPLE M6X1/A	KUGELFETTBSCHSE M6X1/A	GRAISSEUR A BILLES M6X1/A	ENGRAS. DE ESFERAS M6X1/A
65	F01020432	VITE M 8X1,25X16 U5739 8.8 ZN	BOLT M 8X16	SCHRAUBE M 8X16	VIS M 8X16	TORNILLO M 8X16
66	F01410051	ROS.M8 8,4X 17X1,6 U6592 ZN	WASHER M8 8,4X17X1,6 U6592 ZN	SCHEIBE M8 8,4X17X1,6 U6592 ZN	RONDEL. M8 8,4X17X1,6 U6592 ZN	ARANDELA M8 8,4X17X1,6 U6592ZN
67	M37100106	ATTACCO PROTEZIONE	PROTECTION SUPPORT CARDAN	GELENKWELLENSCHUTZ HALTER	SUPPORT PROTECTION	SOPORTE PROTECCION CARDANICO
68	F01020403	VITE M 6X 1X 16 U5739 8.8 ZN	SCREW M6X1X16 U5739 8.8 ZN	SCHRAUBE M6X1X16 U5739 8.8 ZN	VIS M6X1X16 U5739 8.8 ZN	TORNILLO M6X1X16 U5739 8.8 ZN
69	F01410037	ROS.M6 6,4X12,5X1,6 U6592 ZN	PLANE WASHER D.6	SCHEIBE D.6	RONDELLE D.6	ARANDELA D.6
70	M50400207	SCATOLA MOLTIPL.	GEARBOX	WECHSELGETRIEBEGEHAEUSE	BOITE DE VITESSE	CAJA CAMBIO
71	M07700537	BOCCOLA D=65 D=30,3 L=18	BUSHING D=65 D=30,3 L=18	BUECHSE D=65 D=30,3 L=18	BOUCLE D=65 D=30,3 L=18	ARANDELA D=65 D=30,3 L=18
72	F01010337	VITE M16X1,5X 35 U5740 8.8 ZN	BOLT M 16	SCHRAUBE M 16	VIS M 16	TORNILLO M 16
73	F01010341	VITE M16X1,5X45 U5740 8.8ZN	SCR. M16X1,5X45 U5740 8.8ZN	VIS M16X1,5 X45 U5740 8.8 ZN	SCHR.M16X1,5 X45 U5740 8.8 ZN	TORN.M16X1,5 X45 U5740 8.8 ZN
74	F01410100	ROS.M16 17X 30X 3 U6592 ZN	WASHER M16 17X30X3 U6592 ZN	SCHEIBE M16 17X30X3 U6592 ZN	RONDELLE M16 17X30X3 U6592 ZN	ARANDELA M16 17X30X3 U6592 ZN
75	M50400705	PROTEZIONE LATERALE	SIDE PROTECTION	SEITENSCHUTZ	PROTECTION LAT.	PROTECCION LATERAL
76	F01220059	DADO M14X 1,5 D980 8 ZN	NUT M14X 1,5 D980 8 ZB	MUTTER M14X 1,5 D980 8 ZB	ECROU M14X 1,5 D980 8 ZB	TUERCA M14X 1,5 D980 8 ZB
77	F01010318	VITE M14X 1,5X40 U5740 8.8 ZN	BOLT M 14X1,5X40	SCHRAUBE M 14X1,5X40	VIS M 14X1,5X40	TORNILLO M 14X1,5X40
78	M50400706	SUPPORTO SCATOLA	BRACKET	HALTERUNG	SUPPORT	SOPORTE
79	F01200089	DADO M14X 1,5 U5587 6S ZN	NUT M14X 1,5 U5587 6S ZB	MUTTER M14X 1,5 U5587 6S ZB	ECROU M14X 1,5 U5587 6S ZB	TUERCA M14X 1,5 U5587 6S ZB
80	F01010323	VITE M14X1,5 X70 U5740 8.8 ZN	BOLT M 14X1,5X70	SCHRAUBE M 14X1,5X70	VIS M 14X1,5X70	TORNILLO M 14X1,5X70
81	M38100146	MANICOTTO PROTEZIONE PDF	P.T.O. PROTECTION	ZAPFWELLENSCHUTZ P.T.O.	MANCHON DE PROTECTION P.T.O.	MANGUITO PROTECCION P.T.O.
82	M68100106	PROTEZIONE CARDANO	CARDAN PROTECTION	GELENKWELLENSCHUTZ	PROTECTION CARDAN	PROTECCION CARDANICO
83	F01410088	ROS.M14 15X 28X2,5 U6592 ZN	WAS.M14 15X 28X2,5 U6592 ZB	SCH.M14 15X 28X2,5 U6592 ZB	RON.M14 15X 28X2,5 U6592 ZB	ARA.M14 15X 28X2,5 U6592 ZB
84	F01010339	VITE M16X1,5X 40 U5740 8.8 ZN	BOLT M 16X1,5X40	SCHRAUBE M 16X1,5X40	VIS M 16X1,5X40	TORNILLO M 16X1,5X40
85	M50421501	COMP. TELAIO GIRAFFONA 210	COMPLETE FRAME GFHD 210	KOMPL.RAHMEN GFHD 210	CHASSIS COMPL. GFHD 210	TELAR COMPL. GFHD 210
86	M50423501	COMP. TELAIO GIRAFFONA 230	COMPLETE FRAME GFHD 230	KOMPL.RAHMEN GFHD 230	CHASSIS COMPL. GFHD 230	TELAR COMPL. GFHD 230
87	M50425501	COMP. TELAIO GIRAFFONA 260	COMPLETE FRAME GFHD 260	KOMPL.RAHMEN GFHD 260	CHASSIS COMPL. GFHD 260	TELAR COMPL. GFHD 260

TAV. 020

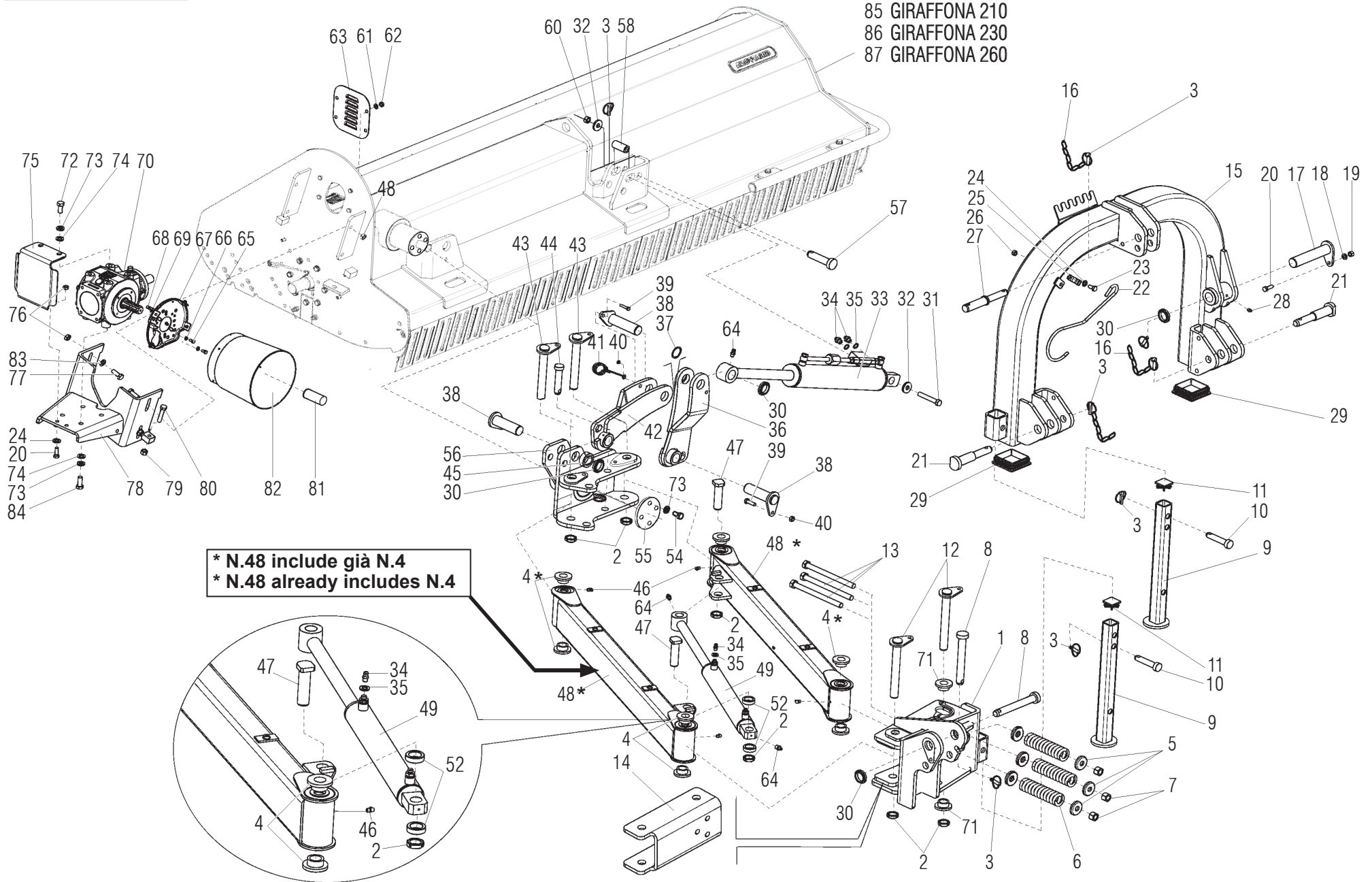

TELAIO SINISTRO E TERZO PUNTO / LEFT FRAME AND 3rd POINT HITCH

TAV. 020

Pos.	Cod.	Descrizione	Description	Benennung	Description	Description
1	M07700525	COMPOSTO ATTACCO 3° PUNTO	LINKAGE 3RD POINT	DREIPUNKTVERBINDUNG	ATTELAGE 3EME POINT	ATAQUE 3 PUNTO
2	F02010133	GHIERA AU.GUP M40X1,5 T.4H ZN	SELF LOCKING NUT M40X1,5	COLLIER AUTOBL.M40X1,5 T.4H ZN	SELBSTSP. NUTMUTTER M40X1,5	VIROLA AUTOBL. M40X1,5 T.4H ZN
3	F02200529	SPINA SCATTO D.11 ZN	SNAP PIN D.11	EINRASTSTIFT D.11	FICHE A DETENTE D.11	CLAVIJA DE MUELLE D.11
4	M07700545	BOCCOLA D=30 D=40 L=30	BUSHING D=30 D=40 L=30	BUECHSE D=30 D=40 L=30	BOUCLE D=30 D=40 L=30	ARANDELA D=30 D=40 L=30
5	G16610430	FONDELLO	BOTTOM	BODENSCHIEBE	CULOT	FONDO
6	M50400567	MOLLA	SPRING	FEDER	RESSORT	MUELLE
7	F01200136	DADO M20X 1,5 U5587 6S ZN	NUT M20X1,5	MUTTER M20X1,5	ECROU M20X1,5	DADO M20X1,5
8	F20100077	PERNO D=28 L=194 ZN	PIN D=28 L=200	STIFT D=28 L=200	GOUJON D=28 L=200	PERNO D=28 L=200
9	M12400590	PIEDINO L=550	SUPPORT	FRASE STANDER	SUPPORT FRAISE	SOPORTE FRESADORA
10	F20100049	PERNO D22 L86 C43 ZN	PIN D.22	BOLZEN D.22	GOUJON D.22	PERNO D.22
11	F20120349	PUNTALE Q.50 ALETT.POLIT.NERO	CAP	DECKEL	BOUCHON	CORCHO
12	M07700534	PERNO D=40 L=263	PIN D=30 L=263	STIFT D=30 L=263	GOUJON D=30 L=263	PERNO D=30 L=263
13	F01010181	VITE M20X1,5X250 U5738 8.8 ZN	BOLT M20X1,5X250	SCHRAUBE M20X1,5X250	VIS M20X1,5X250	TORNILLO M20X1,5X250
14	M07700528	PIASTRA ROTAZIONE	PLATE	PLATTE	PLAQUETTE	PLAQUITA
15	M07700523	CASTELLO 3° PUNTO	COMPLETE 3RD POINT	3. PUNKT KOMPLETT	3EME POINT COMPL.	TERCER PUNTO COMPL.
16	M58100930	ASSIEME CATENELLA L.333 ZN	CHAIN	KETTE	CHAINE	CADENA
17	M50400591	PERNO FLOTTANTE D=40 L=195	PIN D=40 L=195	STIFT D=40 L=195	GOUJON D=40 L=195	PERNO D=40 L=195
18	F01480123	ROS.G 12,5X22,9X 4 EX.C70 ZN	WASHER M12 ZGP EXTRA P.	UNTERLEGSCHIEBE M12 ZGP EXTRA P.	RONDELLE M12 ZGP EXTRA P.	ARANDELA M12 ZGP EXTRA P.
19	F01200073	DADO M12X1,25 U5587 6S ZN	NUT M12X1,25 U5587 6S ZN	MUTTER M12X1,25	ECROU M12X1,25	TUERCA M12X1,25
20	F01010288	VITE M12X1,25X35 U5740 8.8 ZN	SCREW M12X1,25X35 U5740 8.8 ZN	SCHR.M12X1,25X35 U5740 8.8 ZN	VIS M12X1,25X35 U5740 8.8 ZN	TORN.M12X1,25X35 U5740 8.8 ZN
21	M21400563	PERNO ATTACCO BARRA.2°-3° C.	PIN FOR BAR LINKAGE	VERB.BOLZEN SCHUTZHOLM	GOUJON ATTELAGE BARRE	PERNO ATAQUE BARRA
22	F20120400	GANCIO SOSTEGNO CARDANO	SHAFT HOOK	GELENKWELLE - HACKEN	SUPPORT CARDAN	SOPORTE CARDAN
23	F01010281	VITE M12X1,25X25 U5740 8.8 ZN	BOLT M 12X1,25X25	SCHRAUBE M 12X1,25X25	VIS M 12X1,25X25	TORNILLO M 12X1,25X25
24	F01410076	ROS.M12 13X 24X2,5 U6592 ZN	WASHER D12 U6592 ZN	SCHEIBE D12 U6592 ZN	RONDELLE D12 U6592 ZN	ARANDELA D12 U6592 ZN
25	F20120401	FASCETTA FERMA CARDANO ZN	LOCK	ARRET	BLOCKIERUNG	FAJA SEGURO DEL CARDÁN
26	F01220047	DADO M12X1,25 D980 8 ZN	NUT M12X1,25 D980 8 ZN	MUTTER M12X1,25 D980 8 ZN	ECROU M12X1,25 D980 8 ZN	TUERCA M12X1,25 D980 8 ZN
27	F20100130	PERNO ATTACCO TIRANTE	PIN	STIFT	GOUJON	PERNO
28	F01100061	ING.M10X1 7663-A 9SMNPB28 ZN	GREASE NIPPLE M10X1 7663-A ZN	SCHMIERBUECHSE M10X1 7663-A ZN	GRAISSEUR M10X1 7663-A ZN	ENGRASADOR M10X1 7663-A ZN
29	F05100163	TAPPO*PLT X TUBO	CAP	DECKEL	BOUCHON	CORCHO
30	F02010034	GHIERA AU.GUK M40X1,5 T.4H ZN	SELF LOCKING NUT	SELBSTSP. NUTMUTTER	COLLIER AUTOBL.	VIROLA AUTOBL.
31	F01010124	VIT.M16X 1,5X100 U5738 8.8 ZN	BOLT M16X1,5X100	SCHRAUBE M16X1,5X100	VIS M16X1,5X100	TORNILLO M16X1,5X100
32	F01500023	ROS. 17 X45X6 D6340 C50 ZD	ELASTIC DISK	ELASTISCHE SCHEIBE	DISQUE ELASTIQUE	DISCO ELASTICO
33	M50400545	COMP. MART.IDR.A=80 C=400 L712	JACK SCREW ASSY	SPINDELVERSTELLUNGSTEIL	VERIN	MARTINETE
34	F03150310	NIPPLO MM CIL-CIL 3/8-1/4 ZN	NIPPLE CYL.MALE3/8-1/4 ZN	NIPPELZYL.3/8-1/4 ZN	NIPPLE MALE CYL.3/8-1/4 ZN	NIPLE MACHO CIL.3/8-1/4 ZN
35	F03100023	ROS. 17 X23X1,5 RAME -3/8"	WASHER 17X 23X1,5 -3/8"	SCHEIBE 17X 23X1,5 RAME -3/8"	RONDELLE 17X 23X1,5 -3/8"	ARANDELA 17X 23X1,5 -3/8"
36	M07700520	COMPOSTO BIELLA	CONNECTING ROD	PLEUELSTANGE	BIELLE	BIELA
37	M48000307	ANELLO RINF.40X50X1,5 C70 TEMP	STIFFENER RING 40X50X1,5 C70	BAGUE DE RENFORCEM. 40X50X1,5	SEEGER RING 40X50X1,5 C70	ANILLO REFUERZO 40X50X1,5
38	M50400578	PERNO D=40 L=130	PIN D=40 L=130	STIFT D=40 L=130	GOUJON D=40 L=130	PERNO D=40 L=130
39	F01020450	VITE M 8X1,25X40 U5739 8.8 ZN	BOLT M 8X40	SCHRAUBE M 8X40	VIS M 8X40	TORNILLO M 8X40
40	F01220022	DADO M 8X1,25 D980 8 ZN	NUT M8X 1,25 D980 8 ZN	MUTTER M8X 1,25 D980 8 ZN	ECROU M8X 1,25 D980 8 ZN	TUERCA M8X 1,25 D980 8 ZN
41	M21100654	MOLLA PER TUBO SPANDICONC.	SPRING	FEDER	RESSORT	RESORTE
42	M50400562	PIATTO BIELLA	PLATE	PLATTE	PLAT	PLATO
43	M07700540	PERNO D=40 L=207	PIN D=30 L=207	STIFT D=30 L=207	GOUJON D=30 L=207	PERNO D=30 L=207
44	F20100063	PERNO D25 L91 C40 ZN	BOLT D25 L91 C40 ZN	BOLZEN D25 L91 C40 ZN	BOULON D25 L91 C40 ZN	PERNO D25 L91 C40 ZN
45	M09400578	DISTANZIALE D=60 D=40.5 L=22	SPACER	DISTANZSTUECK	ENTRETOISE	DISTANCIADOR

----- CONTINUA A PAGINA SEGUENTE -----
 ----- CONTINUED ON NEXT PAGE -----

TAV. 020

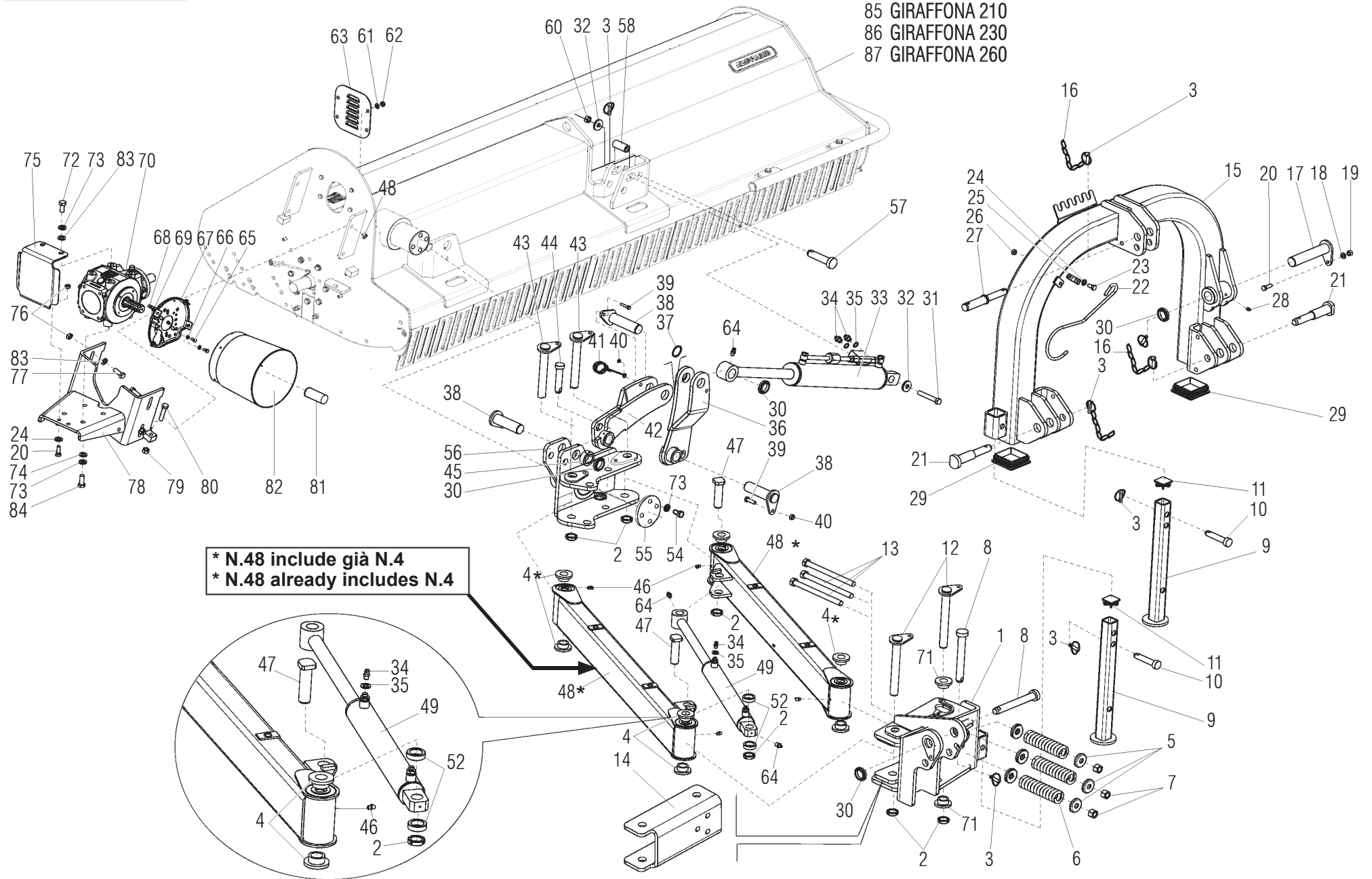

TELAIO SINISTRO E TERZO PUNTO / LEFT FRAME AND 3rd POINT HITCH

TAV. 020

Pos.	Cod.	Descrizione	Description	Benennung	Description	Description
----- CONTINUA DA PAGINA PRECEDENTE ----- ----- CONTINUED FROM PRECEDING PAGE -----						
46	F01100063	ING.M10X1 7663-C 9SMNPB28 ZN	GREASE NIPPLE M10X1	SCHMIERBUECHSE M10X1	GRAISSEUR M10X1	ENGRASADOR M10X1
47	M07700539	COMP.PERNO D=30 L=109	PIN D=30 L=109	STIFT D=30 L=109	GOUJON D=30 L=109	PERNO D=30 L=109
48	M07700529	PARALLELOGRAMMA GIRAFFONA	ARM	ARM	BRAS	BRAZO
49	M50400550	COMP. MART.IDR.A=60 C=380 L630	JACK SCREW ASSY	SPINDELVERSTELLUNGSTEIL	VERIN	MARTINETE
52	M23400528	ROSETTA D=48,3 D=32,5 L=15	WASHER D=48,3 D=32,5 L=15	SCHEIBE D=48,3 D=32,5 L=15	ROSETTE D=48,3 D=32,5 L=15	ARANDELLA D=48,3 D=32,5 L=15
54	F01480145	ROS.G 17X29 X 5 FLZNNC-240H	GROWER WASHER 17X29	RONDELLE GROWER 17X29	SCHEIBE GROWER 17X29	ARANDELA GROWER 17X29
55	M50400785	ROSETTA DI BLOCCAGGIO	PLANE WASHER	SCHEIBE	RONDELLE	ARANDELLA
56	M50400718	GIUNTO MOVIMENTAZIONE	JOINT	VERBINDUNG	JOINT	JUNTA
57	F20100078	PERNO D28 L93 C43 ZN	PIN D.28	BOLZEN D.28	GOUJON D.28	PERNO D.28
58	M50400556	DISTANZIALE D=30 D=20 L=65	SPACER D=30 D=20 L=65	DISTANZST.D=30 D=20 L=65	ENTRETOISE D=30 D=30 L=65	DISTANCIAD.D=30 D=20 L=65
60	F01220070	DADO M16X 1,5 D980 8 ZN	NUT M16X 1,5 D980 8 ZB	MUTT.M16X 1,5 D980 8 ZB	ECRO.M16X 1,5 D980 8 ZB	TUER.M16X 1,5 D980 8 ZB
61	F01410064	ROS.M10 10,5X 20X 2 U6592 ZN	WASHER M10 10,5X20X2 U6592 ZN	SCHEIBE M10 10,5X20X2 U6592 ZN	RONDELL.M10 10,5X20X2 U6592 ZN	ARAND. M10 10,5X20X2 U6592 ZN
62	F01220034	DADO M10X1,25 D980 8 ZN	NUT M10X1,25 D980 8 ZB	MUTT.M10X1,25 D980 8 ZB	ECRO.M10X1,25 D980 8 ZB	TUER.M10X1,25 D980 8 ZB
63	M07400939	CARTER FIANCATA	CARTER	GEHAEUSE	CARTER	CARTER
64	F01100011	INGRAS.A SFERA M6X1 DRITTO A	SPHERE NIPPLE M6X1/A	KUGELFETTBSCHSE M6X1/A	GRAISSEUR A BILLES M6X1/A	ENGRAS. DE ESFERAS M6X1/A
65	F01020432	VITE M 8X1,25X16 U5739 8.8 ZN	BOLT M 8X16	SCHRAUBE M 8X16	VIS M 8X16	TORNILLO M 8X16
66	F01410051	ROS.M8 8,4X 17X1,6 U6592 ZN	WASHER M8 8,4X17X1,6 U6592 ZN	SCHEIBE M8 8,4X17X1,6 U6592 ZN	RONDEL. M8 8,4X17X1,6 U6592 ZN	ARANDELA M8 8,4X17X1,6 U6592 ZN
67	M37100106	ATTACCO PROTEZIONE	PROTECTION SUPPORT CARDAN	GELENKWELLENSCHUTZ HALTER	SUPPORT PROTECTION	SOPORTE PROTECCION CARDANICO
68	F01020403	VITE M 6X 1X 16 U5739 8.8 ZN	SCREW M6X1X16 U5739 8.8 ZN	SCHRAUBE M6X1X16 U5739 8.8 ZN	VIS M6X1X16 U5739 8.8 ZN	TORNILLO M6X1X16 U5739 8.8 ZN
69	F01410037	ROS.M6 6,4X12,5X1,6 U6592 ZN	PLANE WASHER D.6	SCHEIBE D.6	RONDELLE D.6	ARANDELA D.6
70	M07700201	SCATOLA MULTIPL.	GEARBOX	WECHSELGETRIEBEGEHAUSE	BOITE DE VITESSE	CAJA CAMBIO
71	M07700537	BOCCOLA D=65 D=30,3 L=18	BUSHING D=65 D=30,3 L=18	BUECHSE D=65 D=30,3 L=18	BOUCLE D=65 D=30,3 L=18	ARANDELA D=65 D=30,3 L=18
72	F01010337	VITE M16X1,5X 35 U5740 8.8 ZN	BOLT M 16	SCHRAUBE M 16	VIS M 16	TORNILLO M 16
73	F01010341	VITE M16X1,5X45 U5740 8.8ZN	SCR. M16X1,5X45 U5740 8.8ZN	VIS M16X1,5 X45 U5740 8.8 ZN	SCHR.M16X1,5 X45 U5740 8.8 ZN	TORN.M16X1,5 X45 U5740 8.8 ZN
74	F01410100	ROS.M16 17X 30X 3 U6592 ZN	WASHER M16 17X30X3 U6592 ZN	SCHEIBE M16 17X30X3 U6592 ZN	RONDELLE M16 17X30X3 U6592 ZN	ARANDELA M16 17X30X3 U6592 ZN
75	M50400527	PROTEZIONE LATERALE	SIDE PROTECTION	SEITENSCHUTZ	PROTECTION LAT.	PROTECCION LATERAL
76	F01220059	DADO M14X 1,5 D980 8 ZN	NUT M14X 1,5 D980 8 ZB	MUTTER M14X 1,5 D980 8 ZB	ECROU M14X 1,5 D980 8 ZB	TUERCA M14X 1,5 D980 8 ZB
77	F01010318	VITE M14X 1,5X40 U5740 8.8 ZN	BOLT M 14X1,5X40	SCHRAUBE M 14X1,5X40	VIS M 14X1,5X40	TORNILLO M 14X1,5X40
78	M07700510	SUPPORTO SCATOLA	BRACKET	HALTERUNG	SUPPORT	SOPORTE
79	F01200089	DADO M14X 1,5 U5587 6S ZN	NUT M14X 1,5 U5587 6S ZB	MUTTER M14X 1,5 U5587 6S ZB	ECROU M14X 1,5 U5587 6S ZB	TUERCA M14X 1,5 U5587 6S ZB
80	F01010323	VITE M14X1,5 X70 U5740 8.8 ZN	BOLT M 14X1,5X70	SCHRAUBE M 14X1,5X70	VIS M 14X1,5X70	TORNILLO M 14X1,5X70
81	M38100146	MANICOTTO PROTEZIONE PDF	P.T.O. PROTECTION	ZAPFWELLENSCHUTZ P.T.O.	MANCHON DE PROTECTION P.T.O.	MANGUITO PROTECCION P.T.O.
82	M68100106	PROTEZIONE CARDANO	CARDAN PROTECTION	GELENKWELLENSCHUTZ	PROTECTION CARDAN	PROTECCION CARDANICO
83	F01410088	ROS.M14 15X 28X2,5 U6592 ZN	WAS.M14 15X 28X2,5 U6592 ZB	SCH.M14 15X 28X2,5 U6592 ZB	RON.M14 15X 28X2,5 U6592 ZB	ARA.M14 15X 28X2,5 U6592 ZB
84	F01010339	VITE M16X1,5X 40 U5740 8.8 ZN	BOLT M 16X1,5X40	SCHRAUBE M 16X1,5X40	VIS M 16X1,5X40	TORNILLO M 16X1,5X40
85	M07721501	COMP. TELAIO GIRAFFONA 210	COMPLETE FRAME GFHD 210	KOMPL.RAHMEN GFHD 210	CHASSIS COMPL. GFHD 210	TELAR COMPL. GFHD 210
86	M07723501	COMP. TELAIO GIRAFFONA 230	COMPLETE FRAME GFHD 230	KOMPL.RAHMEN GFHD 230	CHASSIS COMPL. GFHD 230	TELAR COMPL. GFHD 230
87	M07725501	COMP. TELAIO GIRAFFONA 260	COMPLETE FRAME GFHD 260	KOMPL.RAHMEN GFHD 260	CHASSIS COMPL. GFHD 260	TELAR COMPL. GFHD 260

- 27 GIRAFFONA 210
- 28 GIRAFFONA 230
- 29 GIRAFFONA 260

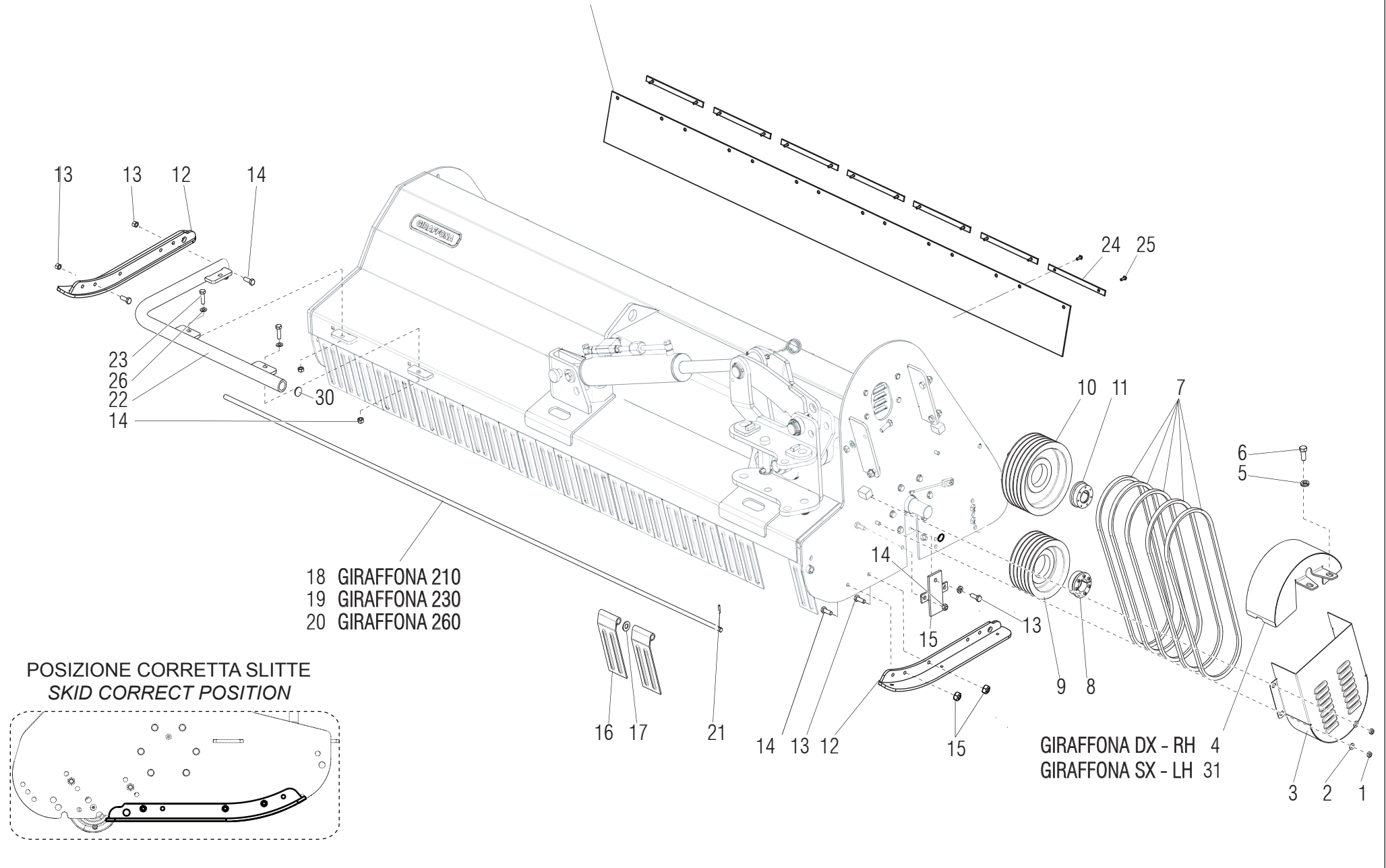

- 18 GIRAFFONA 210
- 19 GIRAFFONA 230
- 20 GIRAFFONA 260

POSIZIONE CORRETTA SLITTE
SKID CORRECT POSITION

GIRAFFONA DX - RH 4
GIRAFFONA SX - LH 31

TRASMISSIONE / TRANSMISSION

TAV. 030

Pos.	Cod.	Descrizione	Description	Benennung	Description	Description
1	F01220034	DADO M10X1,25 D980 8ZN	NUT M10X1,25 D980 8ZN	ECRO.M10X1,25 D980 8 ZB	MUTT.M10X1,25 D980 8 ZB	TUER.M10X1,25 D980 8 ZB
2	F01410064	ROS.M10 10,5X 20X 2 U6592 ZN	WASHER M10 10,5X20X2 U6592 ZN	RONDEL. M10 10,5X20X2 U6592 ZN	SCHIBE M10 10,5X20X2 U6592 ZN	ARANDEL.M10 10,5X20X2 U6592 ZN
3	M50400302	CARTER	CARTER	CARTER	GEHAEUSE	CARTER
4	M50400709	CARTER PROTEZIONE TRASMISSIONE	TRANSMISSION GUARD			
5	F01480145	ROS.G 17X29 X 5 FLZNNC-240H	GROWER WASHER 17X29	RONDELLE GROWER 17X29	SCHEIBE GROWER 17X29	ARANDELA GROWER 17X29
6	F01010337	VITE M16X1,5X35 U5740 8.8ZN	SCR. M16X1,5X35 U5740 8.8ZN	VIS M 16	SCHRAUBE M 16	TORNILLO M 16
7	F06010112	CINGHIA SPB SV. 1600	BELT SPB SV. 1600	COURROIE SPB 1600	SCHAUBE SPB 1600	CORREA SPB 1600
8	F06060039	CALETTATORE AUTOCENTR.45X80	SELF CENTR.CLAMP.EL.45X80	EMBOITEMENT AUTOBLOCANT 45X80		
9	T40005128	PULEGGIA D=200 5V	PULLEY	POULIE	SCHEIBE	ROLDANA
10	T40005120	PULEGGIA D=250 5V	PULLEY TORNADO 230-250-280	POULIE TORNADO 230-250-280	SCHEIBE TORNADO 230-250-280	POLEA TORNADO 230-250-280
11	F06060038	CALETTATORE AUTOCENTR.40X80	SELF CENTR.CLAMP.EL.40X80			
12	M31400532	SLITTA TORNADO	SKID TORNADO	GLISSIERE	GLEITKUFE	TRINEO
13	F01010288	VITE M12X1,25X35 U5740 8.8ZN	SCR. M12X1,25X35 U5740 8.8ZN	VIS M12X1,25X35 U5740 8.8 ZN	SCHR.M12X1,25X35 U5740 8.8 ZN	TORN.M12X1,25X35 U5740 8.8 ZN
14	F01220047	DADO M12X1,25 D980 8ZN	NUT M12X1,25 D980 8ZN	ECROU M12X1,25 D980 8 ZN	MUTTER M12X1,25 D980 8 ZN	TUERCA M12X1,25 D980 8 ZN
15	M03400949	PIATTO CHIUSURA ASOLA	PROTECTION	PROTECTION	SCHUTZ	PROTECCION
16	M31400550	BANDELLA PROTEZIONE L=93 ZN 07	PROTECTION BAR	BANDE PROTECTION	SCHUTZWORNE	ALETA PROTECCION
17	F01410100	ROS.M16 17X 30X 3 U6592 ZN	WASHER M16 17X30X3 U6592 ZN	RONDELLE M16 17X30X3 U6592 ZN	SCHRAUBE M16 17X 30X3 U6592 ZN	ARANDELA M16 17X30X 3 U6592 ZN
18	T24215085	ASTA BANDELLE CR 210	PROTECTION FLAP BAR CR210	TIGE PALETTE PROTECTION CR210	DAS TURBAND STANGE CR210	VARILLA BANDA CR210
19	M03422936	PERNO BANDELLE D=15 L=2302	PIN	GOUJON	BOLZEN	PERNO
20	M03425936	PERNO BANDELLE D=15 L=2606	PIN	GOUJON	BOLZEN	PERNO
21	F02100114	SPINA E.P. 6X 30 U6873 C70 BR	ELASTIC PIN 6X30	GOUJON ELASTIQUE 6X30	SPANNHUELSE 6X30	ESPINA ELASTICA 6X30
22	M50400588	PROTEZIONE ANTERIORE	FRONT PROTECTION	PROTECTION AVANT	VORDERER SCHUTZ	PROTECCION DELANTERA
23	F01010291	VITE M12X1,25X40 U5740 8.8ZN	SCR. M12X1,25X40 U5740 8.8ZN	VIS M12X1,25X40 U5740 8.8 ZN	SCHR.M12X1,25X40 U5740 8.8 ZN	TORN. M12X1,25X40 U5740 8.8 ZN
24	M07400953	PIATTO PER ATTACCO GOMMA	PLATE	PLAT	PLATTE	PLATO
25	F02250160	RIVETTO STR. 6,4X22 ACCIAIO	RIVET	RIVET	KUPFERNIET	REMACHE
26	F01410076	ROS.M12 13X 24X2,5 U6592 ZN	WASHER 12 13X 24X2,5 U6592 ZN	RONDEL. M12 13X24X2,5 U6592 ZN	SCHEIBE M12 13X24X2,5 U6592 ZN	ARANDELA M12 13 X24X2,5 ZN
27	T24215681	PROTEZ. POSTERIORE PVC L=2080	REAR GUARD PVC L=2080			
28	M03422961	PROTEZ. POSTERIORE PVC L=1113	REAR GUARD PVC L=1113			
29	M03425961	PROTEZ. POSTERIORE PVC L=1265	POST PROTECTION PVC L=1265			
30	F05100019	TAPPO AD ALETTA D. 34 PLT	PLUG D.34	BOUCHON FERMETURE D.34	VERSCHLUSSPFRPFEN D.34	TAPON CLAUSURA D.34
31	M07700543	CARTER PROT. TRASM.NE	TRANSMISSION GUARD			

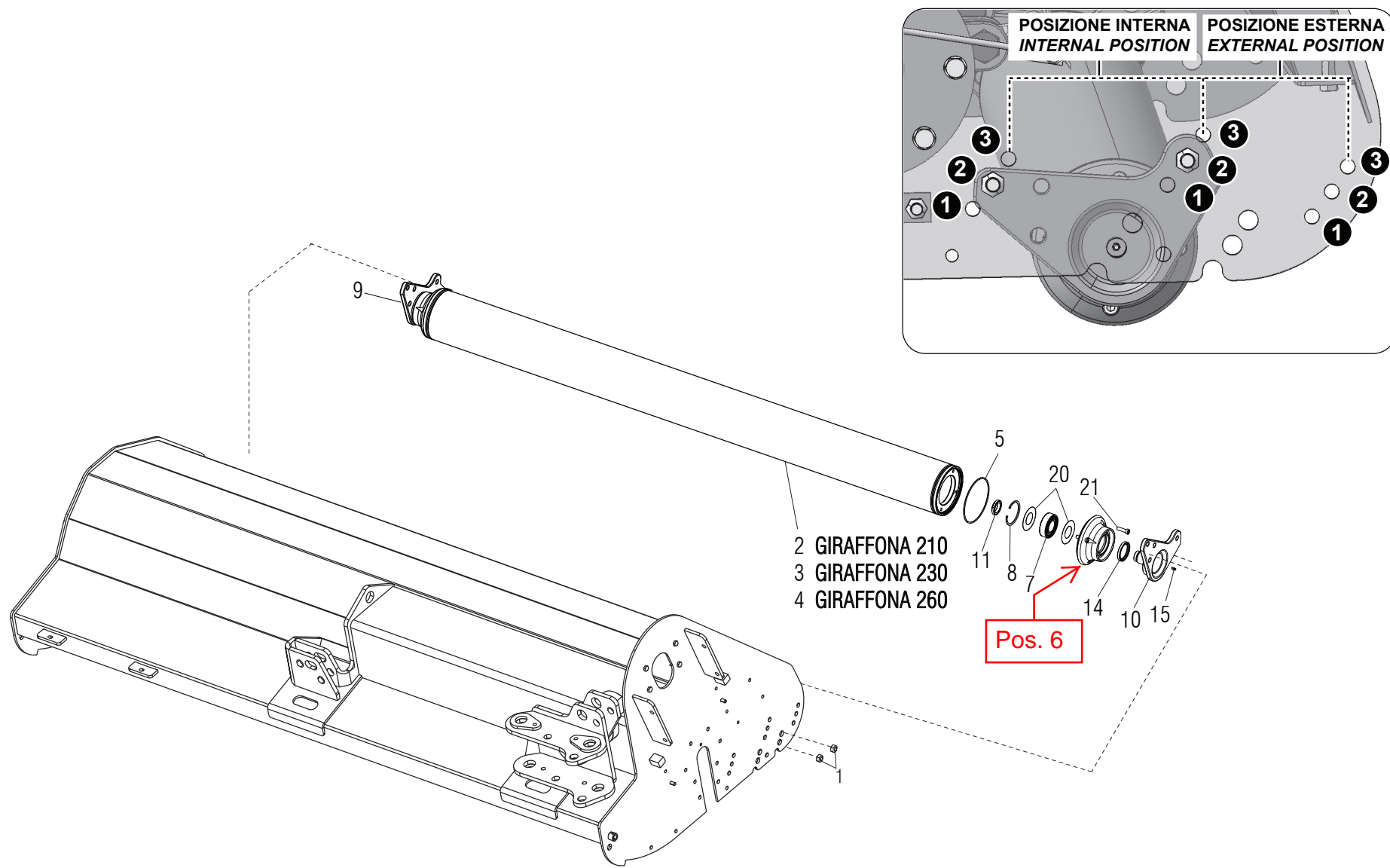

RULLO / ROLLER

TAV. 040

Pos.	Cod.	Descrizione	Description	Benennung	Description	Description
1	F01220059	DADO M14X 1,5 D980 8 ZN	NUT M14X 1,5 D980 8 ZB	MUTTER M14X 1,5 D980 8 ZB	ECROU M14X 1,5 D980 8 ZB	TUERCA M14X 1,5 D980 8 ZB
2	M30421601	ASSIEME RULLO MOD.210	ROLLER ASSEMBLY MOD.210	LAEUFER KOMPL. MOD.210	ROTOR COMPL. MOD.210	ROTOR COMPL. MOD.210
3	M30423601	ASSIEME RULLO MOD.230	ROLLER ASSEMBLY MOD.230	LAEUFER KOMPL. MOD.230	ROTOR COMPL. MOD.230	ROTOR COMPL. MOD.230
4	M30425601	ASSIEME RULLO MOD.260	ROLLER ASSEMBLY MOD.260	LAEUFER KOMPL. MOD.260	ROTOR COMPL. MOD.260	ROTOR COMPL. MOD.260
5	F03010758	ANEL. OR 148,82X3,53 NBR 70	GASKET OR 148,82X3,53 NBR 70	RING OR 148,82X3,53 NBR 70	BAGUE OR 148,82X3,53 NBR 70	ANILLO OR 148,82X3,53 NBR 70
6	M30400607	SUPPORTO CUSCINETTO RULLO	ROLLER SUPPORT	WALZEHALTER	SUPPORT ROULEAU	SOPORTE RODILLO
7	F04010327	CUSC.D40 D80 B23 62208 2RS1	BEARING D40 D80 B23 62208 2RS1	LAGER D40 D80 B23 62208 2RS1	ROULEMENT D40 D80 B23 62208 2RS1	COJINETTE D40 D80 B23 62208 2RS1
8	F02050425	ANELLO E. DI 80X 2,5 U7437 C70	SEEGER RING D.80	SEEGERRING D.80	BAGUE SEEGER D.80	ANILLO SEEGER D.80
9	M30400608	STAFFA RULLO DX	ROLLER SUPPORT	WALZEHALTER	SUPPORT ROULEAU	SOPORTE RODILLO
10	M30400609	STAFFA RULLO SX	ROLLER SUPPORT	WALZEHALTER	SUPPORT ROULEAU	SOPORTE RODILLO
11	F02010022	GHIERA AU.GUK M35X1,5 T.4H ZN	SELF LOCKING NUT M35X1,5	SELBSTSP. NUTMUTTER M35X1,5	COLLIER AUTOBL. M35X1,5	VIROLA AUTOBL. M35X1,5
12	F01410076	ROS.M12 13X 24X2,5 U6592 ZN	WASHER D12 U6592 ZN	SCHEIBE D12 U6592 ZN	RONDELLE D12 U6592 ZN	ARANDELA D12 U6592 ZN
13	F01220047	DADO M12X1,25 D980 8 ZN	NUT M12X1,25 D980 8 ZN	MUTTER M12X1,25 D980 8 ZN	ECROU M12X1,25 D980 8 ZN	TUERCA M12X1,25 D980 8 ZN
14	F03010160	ANELLO T.A. 50X 65X 8 D3760NBR	OIL SEAL 50X65X8	OELABDICHTUNG 50X65X8	PARE-HUILE 50X65X8	PARA-ACEITE 50X65X8
15	F01100011	ING.M 6X1 7663-A 9SMNPB28 ZN	GREASE NIPPLE M6X1 7663-A ZN	SCHMIERBUECHE M6X1 7663-A ZN	GRAISS. A BILLE M6X1 7663A ZN	ENGRAS. DE ESFERAS M6X1 7663-A
16	F01010288	VITE M12X1,25X35 U5740 8.8 ZN	BOLT M12X1,25X35 U5740 8.8 ZN	SCHR.M12X1,25X35 U5740 8.8 ZN	VIS M12X1,25X35 U5740 8.8 ZN	TORN.M12X1,25X35 U5740 8.8 ZN
17	M22421602	RASCHIA FANGO 210	MUD SCRAPER 210	ABSTREIFER FUR SCHLAMM 210	DECROTTOIR POUR BOUE 210	RASCADOR PARA FANGO 210
18	M22423602	RASCHIA FANGO 230	MUD SCRAPER 230	ABSTREIFER FUR SCHLAMM 230	DECROTTOIR POUR BOUE 230	RASCADOR PARA FANGO 230
19	M22425602	RASCHIA FANGO 260	MUD SCRAPER 260	ABSTREIFER FUR SCHLAMM 260	DECROTTOIR POUR BOUE 260	RASCADOR PARA FANGO 260
20	M30400617	ROSETTA SPESS. D=80 D=42 ,5	WASHER M10 10,5X20X2 U6592 ZN	SCHEIBE M10 10,5X20X2 U6592 ZN	RONDELL.M10 10,5X20X2 U6592 ZN	ARAND. M10 10,5X20X2 U6592 ZN
21	F01040110	VIT.M10X1,25X 35 U5931 8.8 ZN	BOLT M10X1,25X35 U5931 8.8 ZN	SCHRAUBE M10X1,25X35 U5931 8.8	VIS M10X1,25X35 U5931 8.8 ZN	TORNILLO M10X1,25X35 U5931 8.8

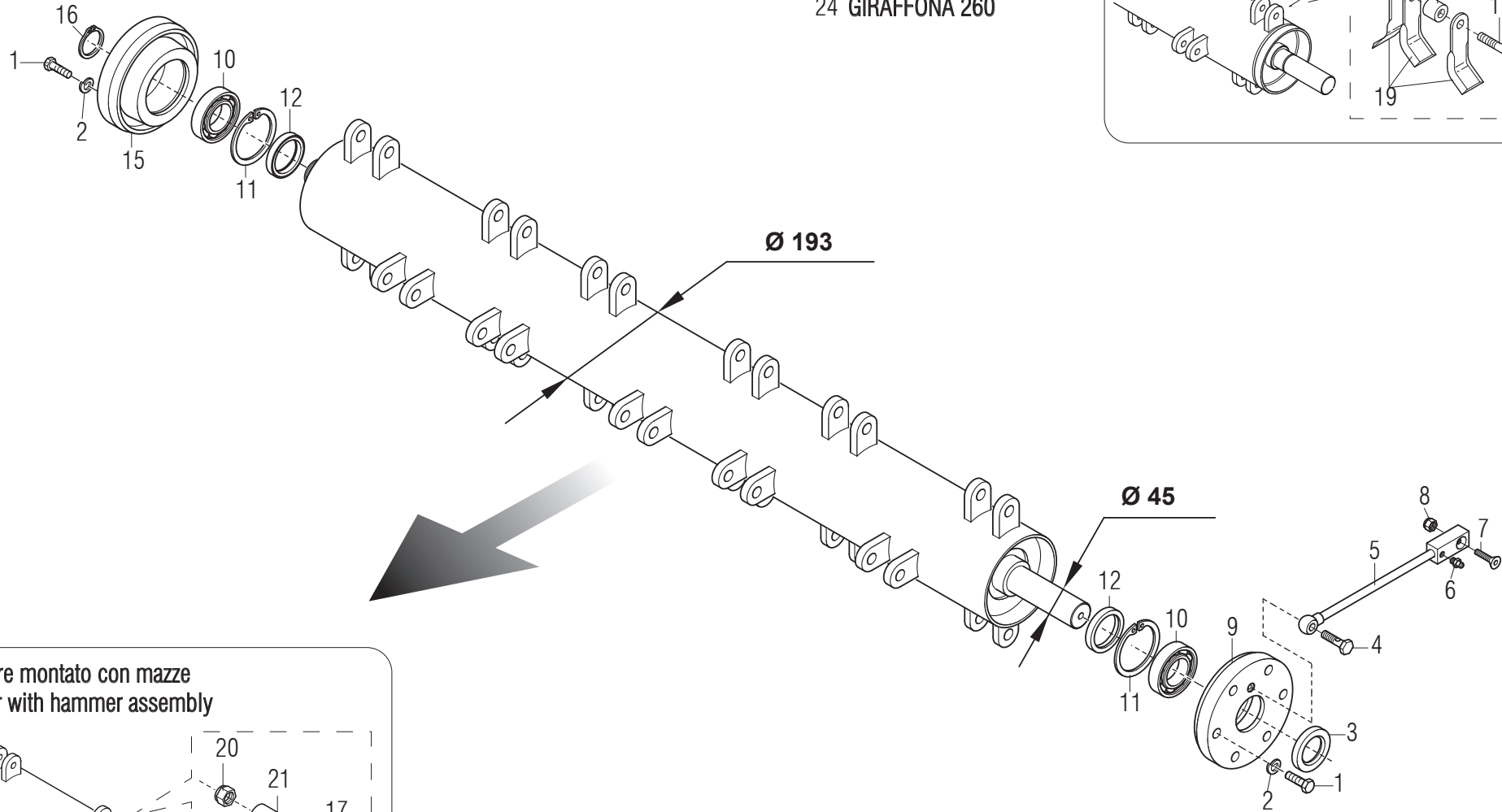

- 22 GIRAFFONA 210
- 23 GIRAFFONA 230
- 24 GIRAFFONA 260

Rotore montato con coltelli
Rotor with knives assembly

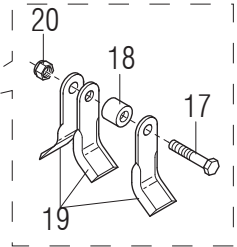

Rotore montato con mazze
Rotor with hammer assembly

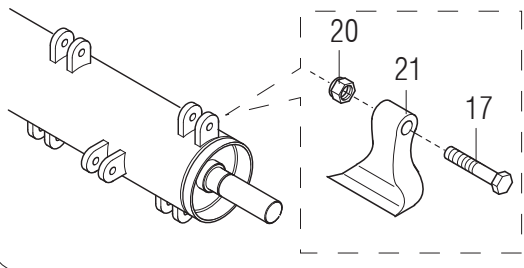

- 25 GIRAFFONA 210
- 26 GIRAFFONA 230
- 27 GIRAFFONA 260

ROTORE / ROTOR

TAV. 050

Pos.	Cod.	Descrizione	Description	Benennung	Description	Description
1	F01010288	VITE M12X1,25X35 U5740 8.8 ZN	SCREW M12X1,25X35 U5740 8.8 ZB	SCHR.M12X1,25X35 U5740 8.8 ZB	VIS M12X1,25X35 U5740 8.8 ZB	TORN.M12X1,25X35 U5740 8.8 ZB
2	F01480123	ROS.G 12,5X22,9X 4 EX.C70 ZN	WASHER M12 ZGP EXTRA P.	UNTERLEGSCHIEBE M12 ZGP EXTRA	RONDELLE M12 ZGP EXTRA P.	ARANDELA M12 ZGP EXTRA P.
3	F03010313	ANELLO T.AS 55X 80X10 D3760NBR	OIL SEAL 55X80X10	OELABDICHTUNG 55X80X10	PARE-HUILE 55X80X10	PARA-ACEITE 55X80X10
4	T24004003	VITE FORATA PER INGRASSAGGIO	BOLT	SCHRAUBE	VIS	TORNILLO
5	T24004000	ASSIEME INGRASSATORE	GREASE NIPPLE	SCHMIERNIPPEL	GRAISSEUR	ENGRASADOR
6	F01100011	INGRAS.A SFERA M6X1 DRITTO	A SPHERE NIPPLE M6X1/A	KUGELFETTBSCHSE M6X1/A	GRAISSEUR A BILLES M6X1/A	ENGRAS. DE ESFERAS M6X1/A
7	F01030058	VITE M 8X1,25X30 U5933 10.9 ZD	SCREW M8X1,25X30 U5933 10,9 ZB	SCHRAUBE M8X1,25X30 U5933 10,9	VIS M8 X1,25 X30 U5933 10,9 ZB	TORNILLO M8X1,25X30 U5933 10,9
8	F01220022	DADO M 8X1,25 D980 8 ZN	SELF LOCKING NUT M8X1,25 980V	SELBSTSP.MUTT. M8X1,25 980-V	ECROU AUTOBL. M8X1,25 980-V	DADO AUTOBL. M8X1,25 980-V
9	M03400456	SUPPORTO ROTORE SX	ROTOR SUPPORT	ROTORHALTER	SUPPORT ROTOR	SOPORTE ROTOR
10	F04010033	CUSC.D55 D100 B25 22211	BEARING D55 D100 B25	ROULEMENT D55 D100 B25	LAGER D55 D100 B25	COJINETE D55 D100 B25
11	F02050471	ANELLO E. DI100X 3 U7437 C70	SEEGER RING D.100	SEEGERRING D.100	BAGUE SEEGER D.100	ANILLO SEEGER D.100
12	F03010218	ANELLO T.A. 65X100X10 D3760NBR	RING T.A. 65X100X10 D3760 NBR	SCHUTZRING 65X100X10 D3760 NBR	BAGUE 65X100X10 D3760 NBR	ANILLO 65X100X10 D3760 NBR
15	M03400455	SUPPORTO ROTORE DX	ROTOR SUPPORT	ROTORHALTER	SUPPORT ROTOR	SOPORTE ROTOR
16	F02050215	ANELLO E. DE 55X 2 U7435 C70	SEEGER RING D.55	SEEGERRING D.55	BAGUE SEEGER D.55	ANILLO D.55
17	F01010175	VITE M20X1,5X120 U5738 8.8 ZN	BOLT M 20X1,5X120	SCHRAUBE M 20X1,5X120	VIS M 20X1,5X120	TORNILLO M 20X1,5X120
18	M03400407	DISTANZIALE D=30 D=20 L=28 ZN	BUSHING	BUECHSE	BOUCLE	ARANDELA
19	M03400406	COLTELLO 15 A Y	BLADE "Y" 15	MESSER "Y" 15	COUTEAU "Y" 15	CUCHILLO "Y" 15
20	F01230258	DADO M20X 1,5 D985 6S ZN	SELF LOCKING NUT M20X1,5	SELBSTSPERR.MUTTER M20X1,5	ECROU AUTOBL. M20X1,5	DADO AUTOBL. M20X1,5
21	M03400410	MAZZA 14	HAMMER 14	SCHLEGEL 14	MARTEAUX 14	MARTILLO 14
22	M3442142002	COMP. R.COLT. TIGRE210 NO SUP.	BLADES HOLDER ROTOR TIGRE 210	MESSERHALTERROTOR TIGRE 210	ROTOR PORTE COUTEAUX TIGRE 210	ROTOR PORTA DIENTES TIGRE 210
23	M3442342002	COMP. R.COLT. TG230 BS220-SUP.	BLADES HOLDER ROTOR TIGRE 230	MESSERHALTERROTOR TIGRE 230	ROTOR PORTE COUTEAUX TIGRE 230	ROTOR PORTA DIENTES TIGRE 230
24	M3442542002	COMP. R.COLT. TIGRE250 NO SUP.	BLADES HOLDER ROTOR TIGRE 250	MESSERHALTERROTOR TIGRE 250	ROTOR PORTE COUTEAUX TIGRE 250	ROTOR PORTA DIENTES TIGRE 250
25	M3442142001	COMP. R.MAZZE TIGRE210 NO SUP.	HAMMERS HOLDER ROTOR TIGRE 210	SCHLEGELHALTERROTOR TIGRE 210	ROTOR PORTE MARTEAUX TIGRE 210	ROTOR PORTA MARTILL.TIGRE 210
26	M3442342001	COMP. R.MAZZE TG230 BS220-SUP.	HAMMERS HOLDER ROTOR TIGRE 230	SCHLEGELHALTERROTOR TIGRE 230	ROTOR PORTE MARTEAUX TIGRE 230	ROTOR PORTA MARTILL.TIGRE 230
27	M3442542001	COMP. R.MAZZE TIGRE250 NO SUP.	HAMMERS HOLDER ROTOR TIGRE 250	SCHLEGELHALTERROTOR TIGRE 250	ROTOR PORTE MARTEAUX TIGRE 250	ROTOR PORTA MARTILL.TIGRE 250

BONDIOLI - per versione destra for right version

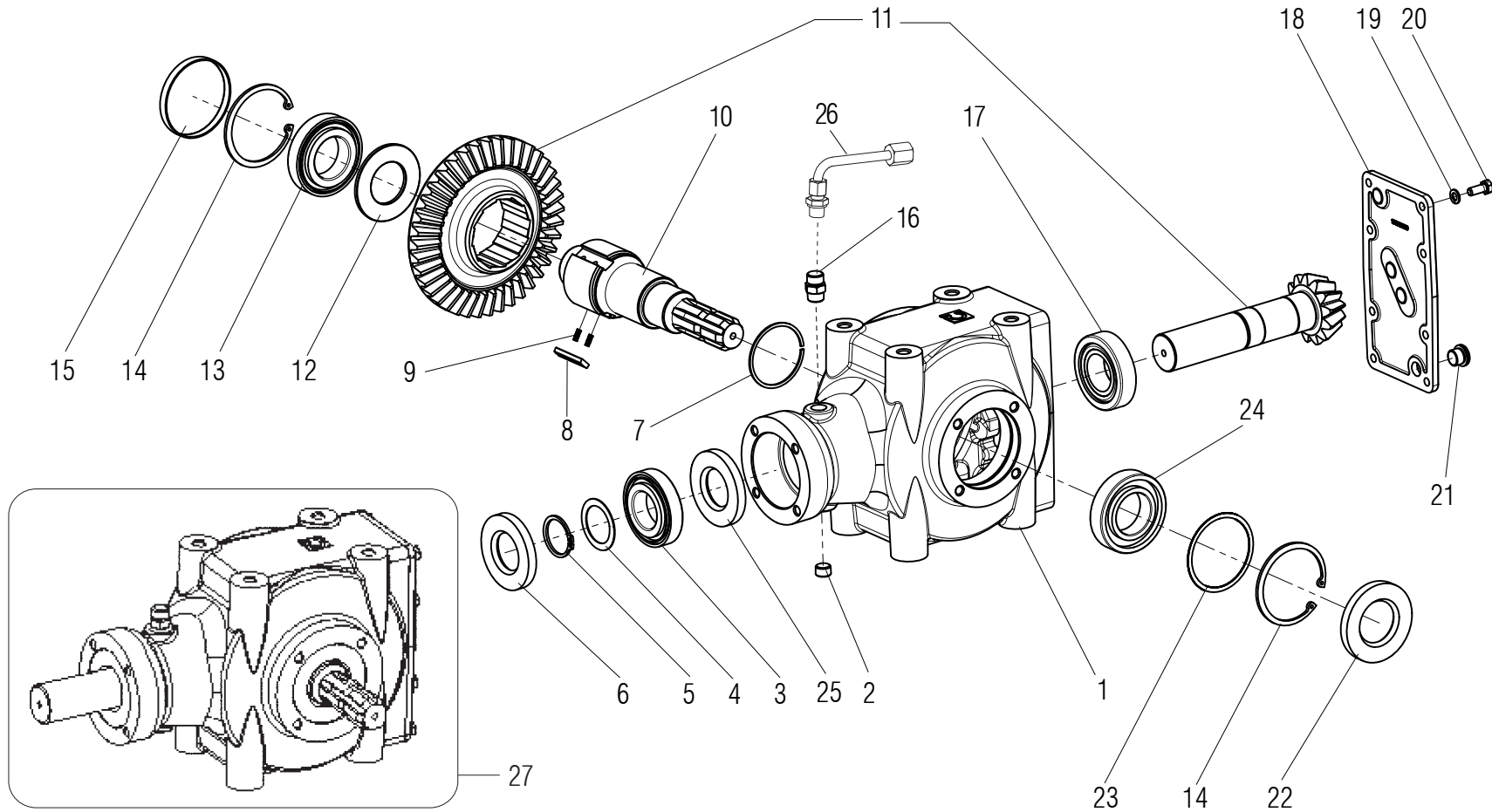

MOLTIPLICATORE 540 rpm - Bondioli per versione destra/ GEARBOX 540 rpm - Bondioli for right version

TAV. 060

Pos.	Cod.	Descrizione	Description	Benennung	Description	Description
1	M50400911	SCATOLA	GEARBOX	WECHSELGETRIEBEGEHAEUSE	BOITE DE VITESSE	CAJA CAMBIO
2	F03150719	TAPPO 3/8 GAS	CAP	DECKEL	BOUCHON	CORCHO
3	F04050017	CUSC.D40 D80 T19,75 30208	BEARING 30208	LAGER 30208	ROULEMENT 30208	COJINETE 30208
4	M50400904	ANELLI DI SPESSORAMENTO E.040	SPACER	DISTANZSTUECK	ENTRETOISE	DISTANCIADOR
5	F02050570	ANELLO E. DE 40X 2,5 U7436 C70	SPACER RING	BAGUE	RING	ANILLO
6	F03010277	ANELLO T.AS 40X 80X10 D3760NBR	OIL SEAL 40X80X10	OELABDICHTUNG 40X80X10	BOURAGE 40X80X10	JUNTA DE ACEITE 40X80X10
7	M50400909	ANELLO EL. E. 68 X1,70	LOCKRING FOR SHAFT	RING	BAGUE D'ARRET	ANILLO ELASTICO
8	M50400903	PIASTRINA	PLATE	PLATTE	PLAQUETTE	PLAQUITA
9	M50400905	MOLLA PER RUOTA LIBERA	SPRING	FEDER	RESSORT	RESSORTE
10	M50400901	ALBERO ASSE.	SHAFT	WELLE	ARBRE	ARBOL
11	M50400912	COPPIA CONICA	BEVEL GEAR PAIR	KEGELRITZELSATZ	COUPLE CONIQUE	PAR CONICO
12	M50400902	DISTANZIALE	SPACER	DISTANZSTUECK	ENTRETOISE	DISTANCIADOR
13	F04050018	CUSC.D45 D85 T20,75 30209	BEARING D45 D85 T20,75 30209	LAGER D45 D85 T20,75 30209	ROULEMENT D45 D85 T20,75 30209	COJINETE D45 D85 T20,75 30209
14	F02050436	ANELLO E. DI 85X 3 U7437 C70	ELASTIC RING UNI 7437	RING UNI 7437	BAGUE ELASTIQUE UNI 7437	ANILLO UNI 7437
15	M50400906	TAPPO CHIUSURA 85X10	COVER D. 85X10	DECKEL D. 85X10	COUVERCLE D. 85X10	TAPA D. 85X10
16	F03150718	TAPPO 3/8" GAS CON SFIATO	OIL BREATHER PLUG	OELENTLUEFTERSTOPFEN	BOUCHON D'HUILE SOUPIRAIL	TAPON ACEITE
17	F04050072	CUSC.D40 D80 T24,75 32208	BEARING 32208	LAGER 32208	ROULEMENT 32208	COJINETE 32208
18	M50400908	KIT COPERCHIO POST.	COVER	DECKEL	COUVERCLE	TAPA
19	F01410051	ROS.D.8	GROWER WASHER D.8	SCHEIBE GROWER D.8	RONDELLE GROWER D.8	ARANDELA GROWER D.8
20	F01020436	VITE M 8X1,25X 20 U5739 8.8 ZN	SCREW M8X1,25X20 U5739 8.8 ZN	SCHRA. M8X1,25X20 U5739 8.8 ZN	VIS M8X1,25X20 U5739 8.8 ZN	TORN. M8X1,25X20 U5739 8.8 ZN
21	M29100112	TAPPO SCARICO OLIO	OIL OUTLET PLUG	OELABLASSPFROPFEN	BOUCHON DE VIDANGE HUILE	TAPON DESCARGADO ACEITE
22	F03010290	ANELLO T.AS 45X 85X10 D3760NBR	OIL SEAL 45X85X10	OELABDICHTUNG 45X85X10	PARE-HUILE 45X85X10	PARA-ACEITE 45X85X10
23	M58100127	KIT SPES.BONDIOLI	REINFORCEMENTS	VERSTAERKERUNGEN	RENFORTS	RENFUERZOS
24	F04010185	CUSC.D45 D85 B19 6209	BEARING D45 D85 6209	LAGER D45 D85 6209	ROULEMENT D45 D85 6209	COJINETE D45 D85 6209
25	F03010119	ANELLO T.AS 40X 72X7 D3760NBR	OIL SEAL	OELABDICHTUNG	PARE-HUILE	PARA-ACEITE
26	M07400216	PROLUNGA*SFIATO 90°	BREATHING PLUG 90°	ENTLUEFTERSTOPFEN 90°	BOUCHON DE SOUPIRAIL 90°	TAPON RESPIRADERO 90°
27	M50400207	SCATOLA MOLTIPL.	COMPLETE GEARBOX	WECHSELGETRIEBE KOMPL.	BOITE DE VITESSE COMPL.	CAJA CAMBIO COMPLETA

BONDIOLI - per versione sinistra for left version

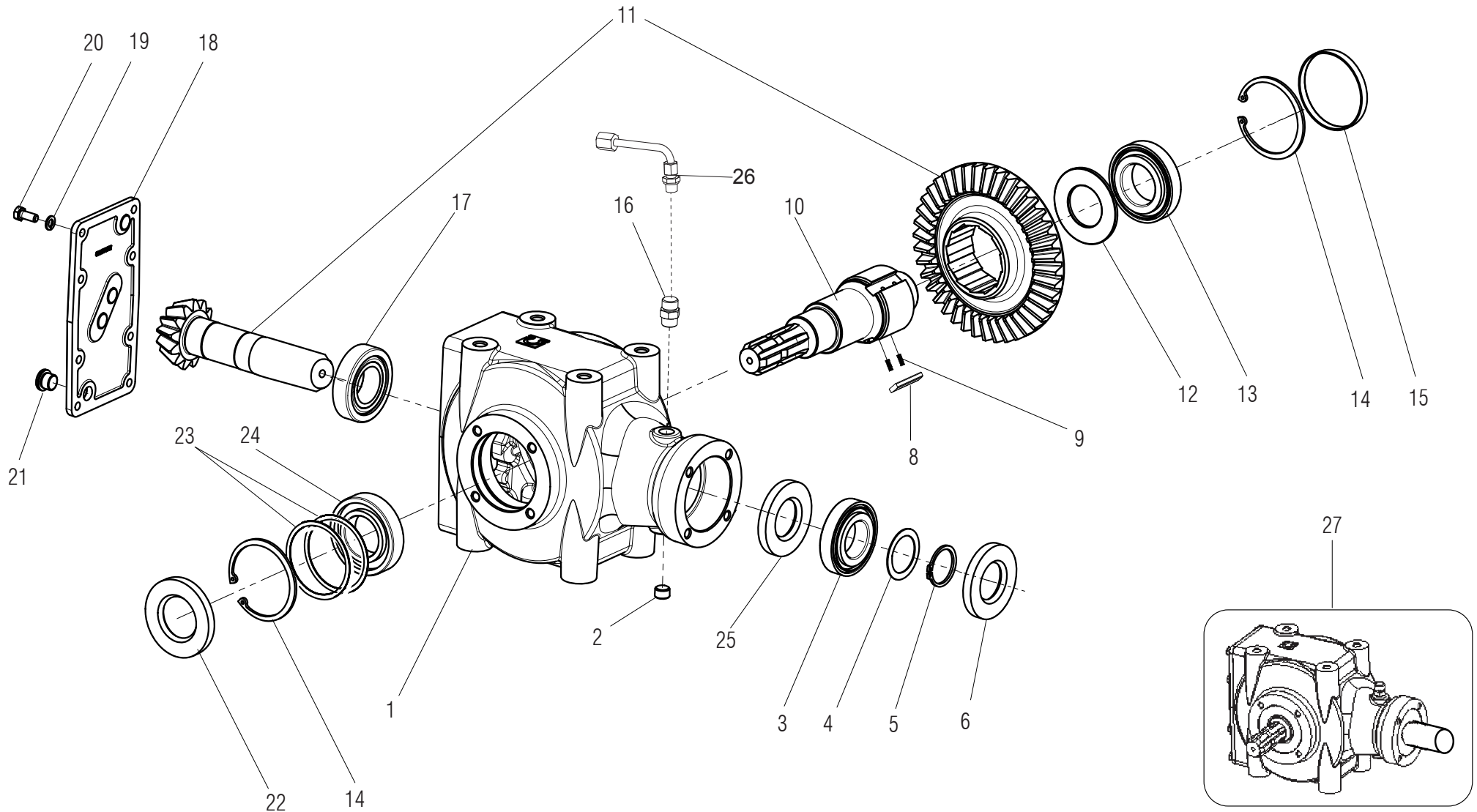

MOLTIPLICATORE 540 rpm - Bondioli per versione sinistra / GEARBOX 540 rpm - Bondioli for left version

TAV. 070

Pos.	Cod.	Descrizione	Description	Benennung	Description	Description
1	M50400911	SCATOLA	GEARBOX	WECHSELGETRIEBEGEHAUEUSE	BOITE DE VITESSE	CAJA CAMBIO
2	F03150719	TAPPO 3/8 GAS	CAP	DECKEL	BOUCHON	CORCHO
3	F04050017	CUSC.D40 D80 T19,75 30208	BEARING 30208	LAGER 30208	ROULEMENT 30208	COJINETE 30208
4	M50400904	ANELLI DI SPESSORAMENTO E.040	SPACER	DISTANZSTUECK	ENTRETOISE	DISTANCIADOR
5	F02050570	ANELLO E. DE 40X 2,5 U7436 C70	SPACER RING	BAGUE	RING	ANILLO
6	F03010277	ANELLO T.AS 40X 80X10 D3760NBR	OIL SEAL 40X80X10	OELABDICHTUNG 40X80X10	BOURAGE 40X80X10	JUNTA DE ACEITE 40X80X10
7	M50400909	ANELLO EL. E. 68 X1,70	LOCKRING FOR SHAFT	RING	BAGUE D'ARRET	ANILLO ELASTICO
8	M50400903	PIASTRINA	PLATE	PLATTE	PLAQUETTE	PLAQUITA
9	M50400905	MOLLA PER RUOTA LIBERA	SPRING	FEDER	RESSORT	RESSORTE
10	M30500156	ALBERO ASSE.	SHAFT	WELLE	ARBRE	ARBOL
11	M30500256	COPPIA CONICA	BEVEL GEAR PAIR	KEGELRITZELSATZ	COUPLE CONIQUE	PAR CONICO
12	M50400902	DISTANZIALE	SPACER	DISTANZSTUECK	ENTRETOISE	DISTANCIADOR
13	F04050018	CUSC.D45 D85 T20,75 30209	BEARING D45 D85 T20,75 30209	LAGER D45 D85 T20,75 30209	ROULEMENT D45 D85 T20,75 30209	COJINETE D45 D85 T20,75 30209
14	F02050436	ANELLO E. DI 85X 3 U7437 C70	ELASTIC RING UNI 7437	RING UNI 7437	BAGUE ELASTIQUE UNI 7437	ANILLO UNI 7437
15	M50400906	TAPPO CHIUSURA 85X10	COVER D. 85X10	DECKEL D. 85X10	COUVERCLE D. 85X10	TAPA D. 85X10
16	F03150718	TAPPO 3/8" GAS CON SFIATO	OIL BREATHER PLUG	OELENTLUEFTERSTOPFEN	BOUCHON D'HUILE SOUPIRAIL	TAPON ACEITE
17	F04050072	CUSC.D40 D80 T24,75 32208	BEARING 32208	LAGER 32208	ROULEMENT 32208	COJINETE 32208
18	M50400908	KIT COPERCHIO POST.	COVER	DECKEL	COUVERCLE	TAPA
19	F01410051	ROS.D.8	GROWER WASHER D.8	SCHEIBE GROWER D.8	RONDELLE GROWER D.8	ARANDELA GROWER D.8
20	F01020436	VITE M 8X1,25X 20 U5739 8.8 ZN	SCREW M8X1,25X20 U5739 8.8 ZN	SCHRA. M8X1,25X20 U5739 8.8 ZN	VIS M8X1,25X20 U5739 8.8 ZN	TORN. M8X1,25X20 U5739 8.8 ZN
21	M29100112	TAPPO SCARICO OLIO	OIL OUTLET PLUG	OELABLASSPFROPFEN	BOUCHON DE VIDANGE HUILE	TAPON DESCARGADO ACEITE
22	F03010290	ANELLO T.AS 45X 85X10 D3760NBR	OIL SEAL 45X85X10	OELABDICHTUNG 45X85X10	PARE-HUILE 45X85X10	PARA-ACEITE 45X85X10
23	M58100127	KIT SPES.BONDIOLI	REINFORCEMENTS	VERSTAERKERUNGEN	RENFORTS	RENFUERZOS
24	F04010185	CUSC.D45 D85 B19 6209	BEARING D45 D85 6209	LAGER D45 D85 6209	ROULEMENT D45 D85 6209	COJINETE D45 D85 6209
25	F03010119	ANELLO T.AS 40X 72X7 D3760NBR	OIL SEAL	OELABDICHTUNG	PARE-HUILE	PARA-ACEITE
26	M07400216	PROLUNGA*SFIATO 90°	BREATHER PLUG 90°	ENTLUEFTERSTOPFEN 90°	BOUCHON DE SOUPIRAIL 90°	TAPON RESPIRADERO 90°
27	M07700201	SCATOLA MOLTIPL.	COMPLETE GEARBOX	WECHSELGETRIEBE KOMPL.	BOITE DE VITESSE COMPL.	CAJA CAMBIO COMPLETA

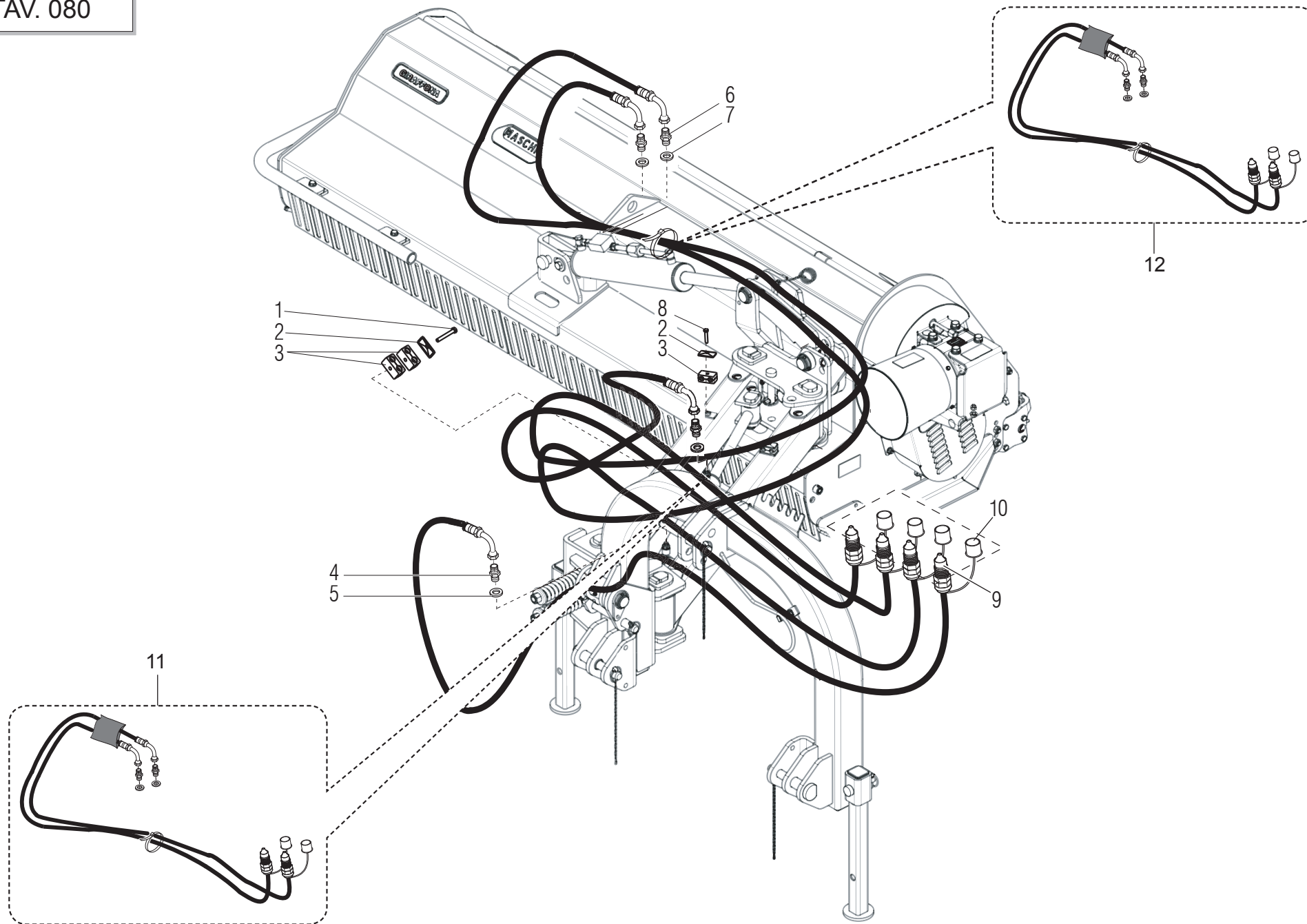

IMPIANTO IDRAULICO - HYDRAULIC PLANT

TAV. 080

Pos.	Cod.	Descrizione	Description	Benennung	Description	Description
1	F01020077	VITE M 8X1,25X60 U5737 8.8 ZN	SCREW M8X1,25X60 U5737 8.8 ZN	SCHRA. M8X1,25X60 U5737 8.8 ZN	VIS M8X1,25X60 U5737 8.8 ZN	TORN. M8X1,25X60 U5737 8.8 ZN
2	F03150993	PIATTO X COLLARE SUPERIORE ZN	PLATE	PLATTE	PLAT	PLATO
3	F03150992	COPPIA COLLARI X TUBO D.16	DOUBLE SUPPORT	DOPPELHALTER	SUPPORT DOUBLE	SOPORTE DOBLE
4	F03150211	NIPPLO MM CIL-CIL 1/2-1/4 ZN	NIPLE MM 1/4-1/2 ZN	NIPLE GG 1/4-1/2 ZN	NIPLE MM 1/4-1/2 ZN	NIPLE MM 1/4-1/2 ZN
5	F03151237	ROS. 21 X27X1,5 RAME -1/2"	COPPER WASHER 21X27X1,5 1/2	SCHEIBE KUPFER 21X27X1,5 1/2	RONDELLE CUIVRE 21X27X1,5 1/2	ARANDELA COBRE 21X27X1,5 1/2
6	F03150211	NIPPLO MM CIL-CIL 1/2-1/4 ZN	NIPLE MM 1/4-1/2 ZN	NIPLE GG 1/4-1/2 ZN	NIPLE MM 1/4-1/2 ZN	NIPLE MM 1/4-1/2 ZN
7	F03151237	ROS. 21 X27X1,5 RAME -1/2"	COPPER WASHER 21X27X1,5 1/2	SCHEIBE KUPFER 21X27X1,5 1/2	RONDELLE CUIVRE 21X27X1,5 1/2	ARANDELA COBRE 21X27X1,5 1/2
8	F01020450	VITE M 8X1,25X40 U5739 8.8 ZN	BOLT M 8X40	SCHRAUBE M 8X40	VIS M 8X40	TORNILLO M 8X40
9	F03150935	INNESTO RAP.MASCH.1/2 A VALV.	QUICK CONNECT MALE CONE 1/2	CONNEXION RAPIDE MALE CONE 1/2	SCHNELLKUPP.GEWINDE KONISC 1/2	ACOPLAMIEN.RAP.MACHO CONO 1/2
10	F05150325	CAPPUC.F X INN.M RAP.1/2 ROSSO	COVER CONNECT F 1/2 RED	COUVERCLE CONNEXION F 1/2 ROSE	DECKEL W 1/2 SCHNELLKUPP. ROT	PAC PROTECCION F 1/2 ROJO
11	F03060023	KIT TUBAZIONI IDR.X GFN L=2900	HIDRAULIC CONNECTIONS KIT	KIT HYDRAULIC TUBE	KIT HYDRAUL. ROHR	KIT HIDRAULICO
12	F03060021	KIT TUBAZ.IDR.X GFN L=4900	HIDRAULIC CONNECTIONS KIT	KIT HYDRAULIC TUBE	KIT HYDRAUL. ROHR	KIT HIDRAULICO

**SLITTA ANTIUSURA
NO WEAR SKID**

OPTIONAL

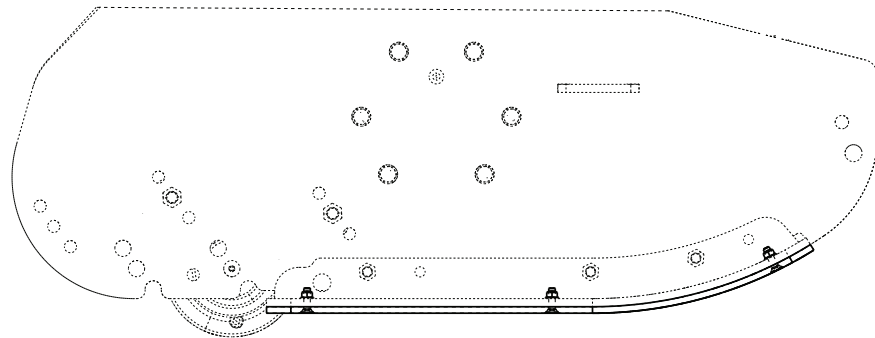
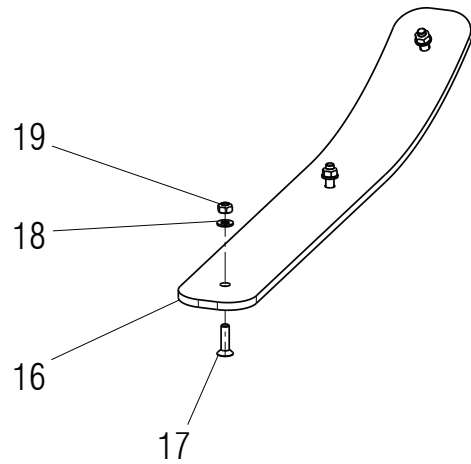

**CONVOGLIATORE INTERNO
INTERNAL CONVEYOR**

OPTIONAL

- 1 - GIRAFFONA 210
- 2 - GIRAFFONA 230
- 3 - GIRAFFONA 260

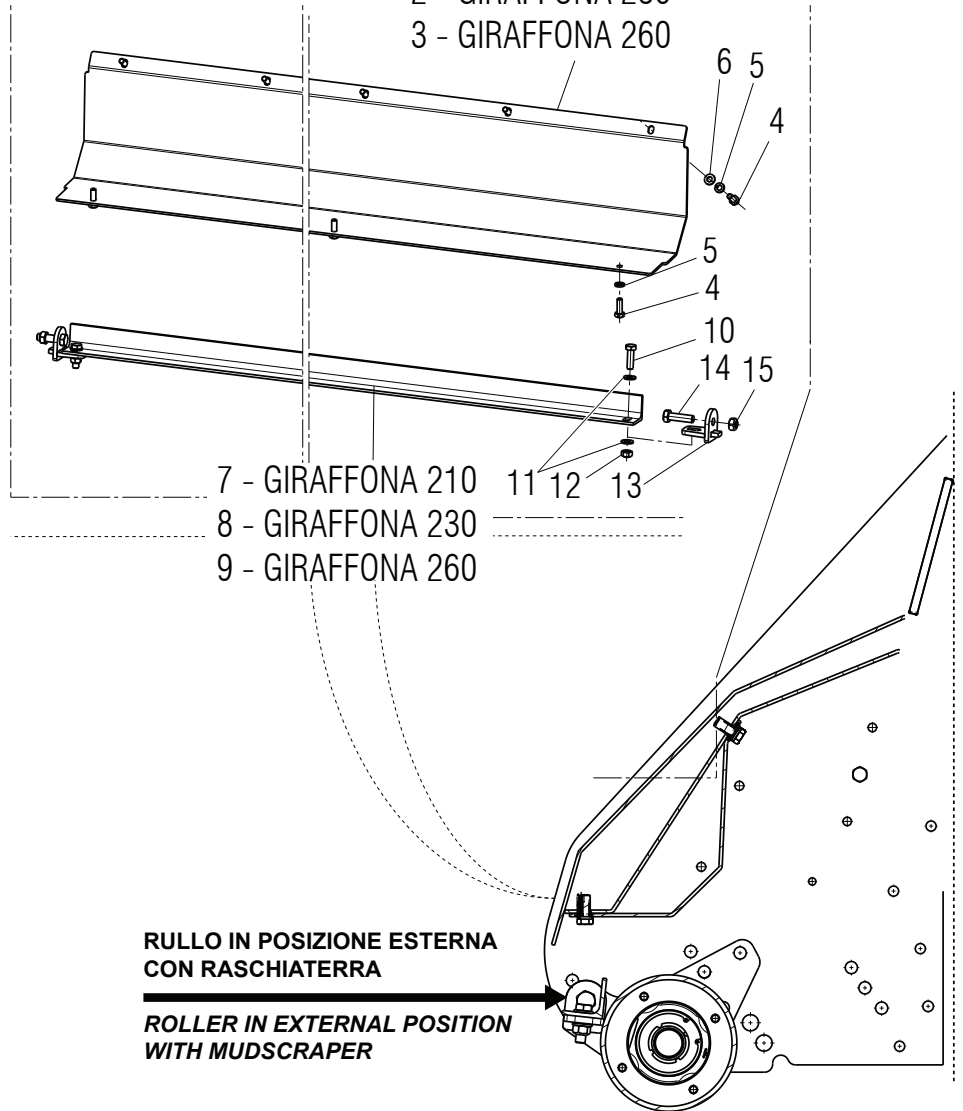

**RULLO IN POSIZIONE ESTERNA
CON RASCHIATERRA**

**ROLLER IN EXTERNAL POSITION
WITH MUDSCRAPER**

ACCESSORI OPTIONAL - OPTIONAL FITTING

TAV. 090

Pos.	Cod.	Descrizione	Description	Benennung	Description	Description
1	M50421738	CONVOGLIATORE INTERNO	INTERNAL CONVEYOR			
2	M50423738	CONVOGLIATORE INTERNO	INTERNAL CONVEYOR			
3	M50425738	CONVOGLIATORE INTERNO	INTERNAL CONVEYOR			
4	F01020476	VITE M10X1,5X30 U5739 8.8ZN	SCR. M10X1,5X30 U5739 8.8ZN	VIS M10X1,5X30 U5739 8.8 ZN	SCHRAUBE M10X1,5X30U5739 8.8ZN	TORNIL.M10X1,5X30 U5739 8.8 ZN
5	F01480112	ROS.G 10,5X19X 3 FLZNNC - 240H	GROWER WASHER D.10	RONDELLE GROWER D.10	SCHEIBE GROWER D.10	ARANDELA GROWER D.10
6	F01410064	ROS.M10 10,5X 20X 2 U6592 ZN	WASHER M10 10,5X20X2 U6592 ZN	RONDEL. M10 10,5X20X2 U6592 ZN	SCHEIBE M10 10,5X20X2 U6592 ZN	ARANDEL.M10 10,5X20X2 U6592 ZN
7	M50421737	RASCHIATERRA	MUD SCRAPER			
8	M50423737	RASCHIATERRA	MUD SCRAPER			
9	M50425737	RASCHIATERRA	MUD SCRAPER			
10	F01010291	VITE M12X1,25X40 U5740 8.8ZN	SCR. M12X1,25X40 U5740 8.8ZN	VIS M12X1,25X40 U5740 8.8 ZN	SCHR.M12X1,25X40 U5740 8.8 ZN	TORN. M12X1,25X40 U5740 8.8 ZN
11	F01410076	ROS.M12 13X 24X2,5 U6592 ZN	WASHER 12 13X 24X2,5 U6592 ZN	RONDEL. M12 13X24X2,5 U6592 ZN	SCHEIBE M12 13X24X2,5 U6592 ZN	ARANDELA M12 13 X24X2,5 ZN
12	F01220047	DADO M12X1,25 D980 8ZN	NUT M12X1,25 D980 8ZN	ECROU M12X1,25 D980 8 ZN	MUTTER M12X1,25 D980 8 ZN	TUERCA M12X1,25 D980 8 ZN
13	M30400619	SUPPORTO	SUPPORT			
14	F01010320	VITE	SCREW			
15	F01220059	DADO M14X1,5 D980 8ZN	NUT M14X1,5 D980 8ZN	ECROU M14X 1,5 D980 8 ZN	MUTTER M14X 1,5 D980 8 ZN	TUERCA M14X 1,5 D980 8 ZN
16	M50400778	SLITTA ANTIUSURA	NO WEAR SKID			
17	F01030058	VITE M8X1,25X30 U5933 10.9ZD	SCR. M8X1,25X30 U5933 10.9ZD	VIS M8 X1,25 X30 U5933 10,9 ZD	SCHRAUBE M8X1,25X30 U5933 10,9	TORNILLO M8X1,25X30 U5933 10,9
18	F01410051	ROS.M8 8,4X 17X1,6 U6592 ZN	WASHER M8 8,4X17X1,6 U6592 ZN	RONDELLE M8 8,4X17X1,6 U6592ZN	SCHEIBE M8 8,4X17X1,6 U6592 ZN	ARANDELA M8 8,4X17X1,6 U6592ZN
19	F01220022	DADO M8X1,25 D980 8ZN	NUT M8X1,25 D980 8ZN	ECROU M8X 1,25 D980 8 ZN	MUTTER M8X 1,25 D980 8 ZN	TUERCA M8X 1,25 D980 8 ZN

**ASSIEME ROTORE SPECIALE A MAZZE "14"
TYPE "14" HAMMERS SPECIAL ROTOR ASSEMBLY**

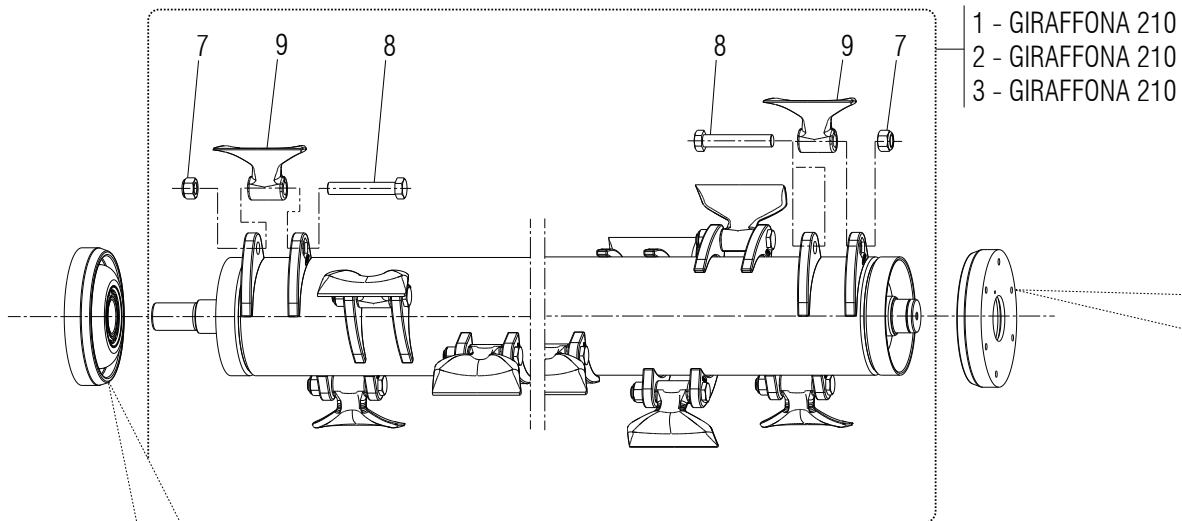

- 1 - GIRAFFONA 210
- 2 - GIRAFFONA 210
- 3 - GIRAFFONA 210

**SUPPORTO ROTORE DX
RH ROTOR SUPPORT**

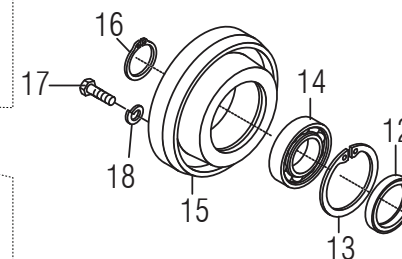

**ASSIEME ROTORE SPECIALE A COLTELLI "15"
TYPE "15" KNIVES SPECIAL ROTOR ASSEMBLY**

**SUPPORTO ROTORE SX
LH ROTOR SUPPORT**

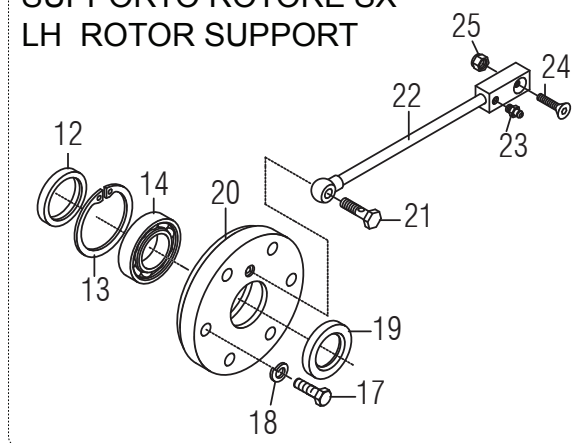

- 4 - GIRAFFONA 210
- 5 - GIRAFFONA 210
- 6 - GIRAFFONA 210

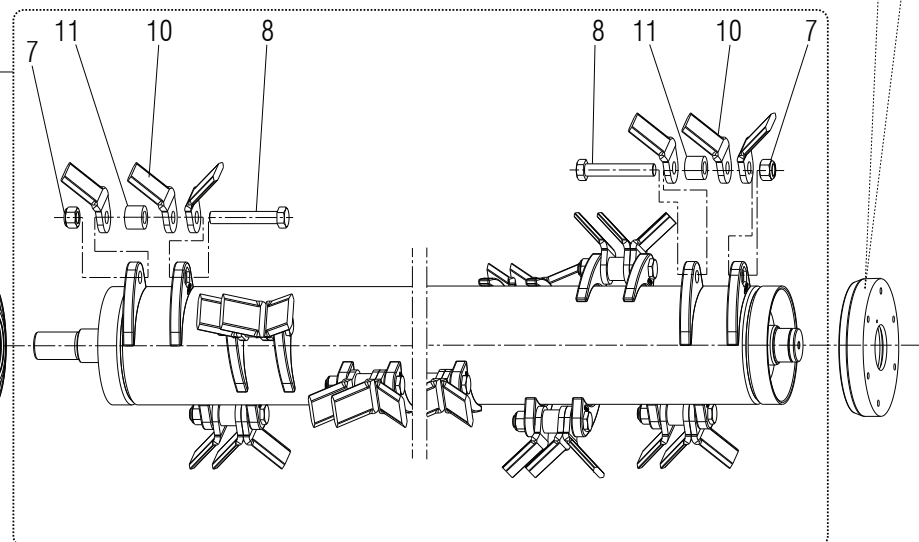

ROTORE SPECIALE OPTIONAL - OPTIONAL SPECIAL ROTOR

TAV. 100

Pos.	Cod.	Descrizione	Description	Benennung	Description	Description
1	M34421431	ROTORE SPECIALE M14 NO SUP.	SPECIAL ROTOR M14			
2	M34423431	ROTORE SPECIALE M14 NO SUP.	SPECIAL ROTOR M14			
3	M34425431	ROTORE SPECIALE M14 NO SUP.	SPECIAL ROTOR M14			
4	M34421432	COMP.ROTORE SPEC.C15 NO SUP.	SPECIAL ROTOR C15			
5	M34423432	COMP.ROTORE SPEC.C15 NO SUP.	SPECIAL ROTOR C15			
6	M34425432	COMP.ROTORE SPEC.C15 NO SUP.	SPECIAL ROTOR C15			
7	F01230258	DADO M20X1,5 U7474 8SZN	NUT M20X1,5 U7474 8SZN	ECROU AUTOBL. M20X1,5	SELBSTSPERR.MUTTER M20X1,5	DADO AUTOBL. M20X1,5
8	F20110092	VIT. M20X1.5X116 SPEC. BR.8.8	BOLT M20X1.5X116 SPEC. BR.8.8		BOZEN M20X1.5X116 SPEC. BR.8.8	TORNILLO AUTOBL. M20X1
9	M03400410	MAZZA 14	HAMMER 14			MARTILLO 14
10	M03400406	COLTELLO 15 A Y	BLADE "Y" 15	COUTEAU "Y" 15	MESSER "Y" 15	CUCHILLO "Y" 15
11	M03400407	DISTANZIALE D=38 D=20 L=29 ZN	BUSHING	BOUCLE	BUECHSE	ARANDELA
12	F03010218	ANELLO T.A. 65X100X10 D3760NBR	OIL SEAL 65X100X10	PARE-HUILE 65X100X10 D3760NBR	OELABDICHTUNG 65X100X10 D3760	ANILLO 65X100X10
13	F02050471	ANELLO E. DI100X 3 U7437 C70	SEEGER RING D.100	BAGUE SEEGER D.100	SEEGERRING D.100	ANILLO SEEGER D.100
14	F04010033	CUSC.D55 D100 B25 22211	BEARING D55 D100 B25	ROULEMENT D55 D100 B25	LAGER D55 D100 B25	COJINETE D55 D100 B25
15	M03400455	SUPPORTO ROTORE DX	RIGHT ROTOR SUPPORT			
16	F02050215	ANELLO E. DE 55X 2 U7435 C70	RET. RING FOR SHAFT 55X2 U7435	BAGUE ELASTIQUE UNI 7435	RING 55X 2 U7435 C70	ANILLO UNI 7435
17	F01010288	VITE M12X1,25X35 U5740 8.8ZN	SCR. M12X1,25X35 U5740 8.8ZN	VIS M12X1,25X35 U5740 8.8 ZN	SCHR.M12X1,25X35 U5740 8.8 ZN	TORN.M12X1,25X35 U5740 8.8 ZN
18	F01480123	ROS.G 12,5X22,9X 4 FLZNNC-240H	WASHER M12 ZGP EXTRA P.	RONDELLE M12 ZGP EXTRA P.	UNTERLEGSSCHEIBE M12 ZGP EXTRA	ARANDELA M12 ZGP EXTRA P.
19	F03010313	ANELLO T.AS 55X 80X10 D3760NBR	OIL SEAL 55X 80X10 D3760NBR	BAGUE T.AS 55X 80X10 D3760NBR	SCHUTZRING 55X 80X10 D3760NBR	ANILLO T.AS 55X 80X10 D3760NBR
20	M03400456	SUPPORTO ROTORE SX	LEFT ROTOR SUPPORT			
21	T24004003	VITE FORATA PER INGRASSAGGIO	BOLT	VIS	SCHRAUBE	TORNILLO
22	T24004000	ASSIEME INGRASSATORE	GREASE NIPPLE	GRAISSEUR	SCHMIERNIPPEL	ENGRASADOR
23	F01100011	ING.M 6X1 7663-A 9SMNPB28 ZN	GREASE NIPPLE M6X1 7663-A ZN	GRAISS. A BILLE M6X1 7663A ZN	SCHMIERBUECHE M6X1 7663-A ZN	ENGRAS. DE ESFE. M6X1 7663-AZN
24	F01030058	VITE M8X1,25X30 U5933 10.9ZD	SCR. M8X1,25X30 U5933 10.9ZD	VIS M8 X1,25 X30 U5933 10,9 ZD	SCHRAUBE M8X1,25X30 U5933 10,9	TORNILLO M8X1,25X30 U5933 10,9
25	F01220022	DADO M8X1,25 D980 8ZN	NUT M8X1,25 D980 8ZN	ECROU M8X 1,25 D980 8 ZN	MUTTER M8X 1,25 D980 8 ZN	TUERCA M8X 1,25 D980 8 ZN

TAV. 110

WALTERSCHEID

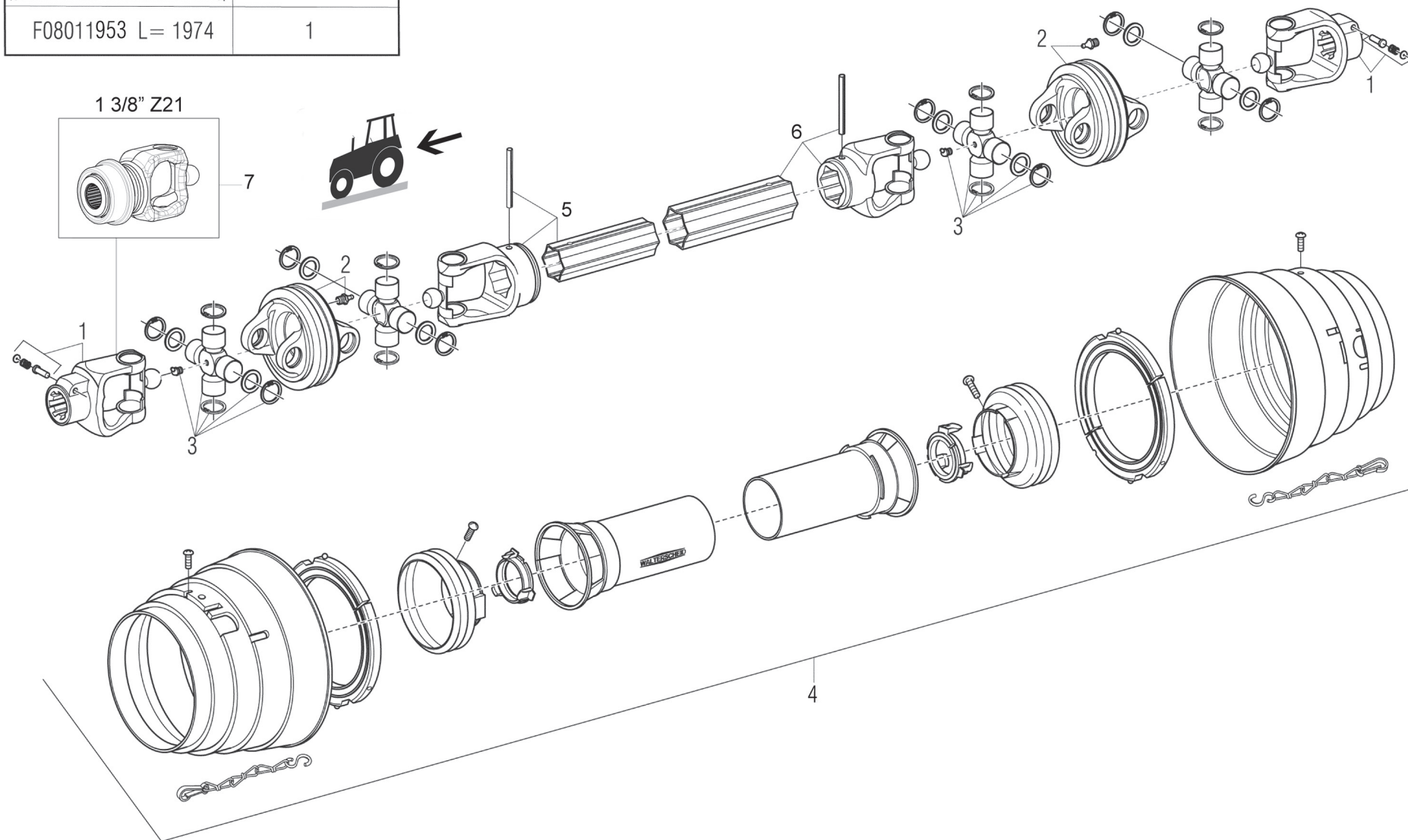
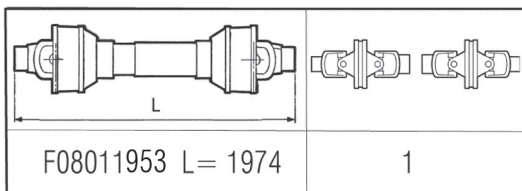

CARDANO OMOCINETICO WALTERSCHEID / WALTERSCHEID COSTANT VELOCITY PTO SHAFT

TAV. 110

Pos.	Cod.	Descrizione	Description	Benennung	Description	Description
1	F08012027	FORC.ASG WS 3/8 Z6	LINKAGE FORK	GABELSTUECK	FOURCHE ATTELAGE	HORQUILLAATAQUE
2	F08012030	FORC.DOP.	DOUBLEYOKE+GREASENIPPLE	DOPPELGABEL+SCHMIERNIPPEL	MACHOIRE DOUBLE+GRAISSEUR	HORQUILLA DOBLA+ENGRASADOR
3	F08012029	CROC. WS	SPIDER ASSY	GELENKKREUZ KOMPL.	CROISIERE COMPL.	CRUCETA COMPLETA
4	F08012033	PROT.	CARDAN PROTECTION	GELENKWELLENSCHUTZ	PROTECTION CARDAN	PROTECCION CARDANICO
5	F08010723	FORCELLA +TUBO INTERNO +SPINA	FORK WITH INTERNAL PIPE			
6	F08010724	FORCELLA +TUBO ESTERNO +SPINA	FORK WITH EXTERNAL PIPE			
7	F08012038	FORC.AS WS1'3/8Z21*	MFORC.AS WS1'3/8Z21*			

**USATE SEMPRE RICAMBI ORIGINALI
ALWAYS USE ORIGINAL SPARE PARTS
IMMER DIE ORIGINAL-ERSATZTEILE VERWENDEN
EMPLOYEZ TOUJOURS LES PIECES DE RECHANGE ORIGINALES
UTILIZAR SIEMPRE REPUESTOS ORIGINALES**



Servizio Assistenza Tecnica - After Sales Service

+39 049 9289960

+39 049 9289836

Servizio Ricambi - Spare Parts Service

+39 049 9289888

DEALER:



MASCHIO GASPARDO SpA

Registered Office and Production Plant

Via Marcello, 73 - 35011 Campodarsego (Padova) - Italy

Tel. +39 049 9289810

Fax +39 049 9289900

info@maschio.com

www.maschionet.com

MASCHIO DEUTSCHLAND GMBH

Außere Nürnberger Straße 5

D - 91177 Thalmässing - Deutschland

Tel. +49 (0) 9173 79000

Fax +49 (0) 9173 790079

dialog@maschio.de

www.maschionet.de

MASCHIO FRANCE Sarl

1 rue Denis Papin ZA

F - 45240 La Ferte St. Aubin

France

Tel. +33 (0) 2.38.64.12.12

Fax +33 (0) 2.38.64.66.79

info@maschio.fr

000 MASCHIO-ГАСПАРДО РУССИЯ

04130, Россия,

Волгоградская область,

г. Волжский, ул. Пушкина, 117 «б».

Тел.: +7 8443 203100

факс: +7 8443 203101

e-mail: info@maschio.ru

MASCHIO GASPARDO SpA

Production Plant

Via Mussons, 7 - 33075 Morsano al Tagliamento (PN) - Italy

Tel. +39 0434 695410

Fax +39 0434 695425

info@gaspardo.it

MASCHIO GASPARDO NORTH AMERICA Inc.

112 3rd Avenue East

DeWitt - IA 52742

Ph. +1 563 6596400

Fax +1 563 6596404

info@maschio.us

MASCHIO-GASPARDO ROMANIA S.R.L.

Strada Înfrătirii, F.N.

315100 Chisineu-Cris (Arad) -România

Tel. +40 257 307030

Fax +40 257 307040

info@maschio.ro

MASCHIO IBERICA S.L.

MASCHIO-GASPARDO POLAND

MASCHIO-GASPARDO UCRAINA

GASPARDO-MASCHIO TURCHIA

MASCHIO-GASPARDO CINA

MASCHIO-GASPARDO INDIA

MASCHIO-GASPARDO KOREA