

Pièces de rechange
Spare parts list
Ersatzteilliste
Catalogo Pezzi di Ricambio



CHARRUE PORTEE
MOUNTED REVERSIBLE PLOUGH
VOLLDREHPFLUG
ARATRO PORTATO



J8584 > K9999

MULTI-MASTER 152 TA





SIGNES CODIFIÉS - STANDARD SYMBOLS - SYMBOLE - SIMBOLI CODIFICATI

OPT	Equipement optionnel
STD	Equipement livré de série
ESP	Equipement livré suivant pays
:	Pour ...
>	De ... à ...
RPL	Remplace ...
∅	Diamètre
> <	Epaisseur
<->	Longueur
<m>	Vendu au mètre
Q?	Quantité selon besoin
*	Voir note
[n]	Composant d'un assemblage
+ [n]	Assemblage comprenant les pièces [n]

OPT	Optional equipment
STD	Equipment supplied as standard
ESP	Equipment supplied for specific countries
:	For ...
>	From ... to ...
RPL	Replaces ...
∅	Diameter
> <	Thickness
<->	Length
<m>	Sold by the metre
Q?	Quantity as required
*	See note
[n]	Items making up assembly
+ [n]	Assembly made up by items [n]

OPT	Sonderausrüstung
STD	Serienausrüstung
ESP	Länderabhängige Ausrüstung
:	Für ...
>	Von ... bis ...
RPL	Ersetzt ...
∅	Durchmesser
> <	Stärke
<->	Länge
<m>	Meterware
Q?	Stückzahl nach Bedarf
*	Siehe Nota
[n]	Teil einer Baugruppe
+ [n]	Baugruppe bestehend aus den mit [n] bezeichneten Teilen

OPT	Attrezzatura opzionale
STD	Attrezzatura fornita di serie
ESP	Attrezzatura fornita secondo il paese
:	Per ...
>	Da ... A ...
RPL	Sostituisce ...
∅	Diametro
> <	Spessore
<->	Lunghezza
<m>	venduto a metro
Q?	Quantità richiesta
*	Vedi nota
[n]	Componente di un assieme
+ [n]	Assieme comprendente i componenti [n]

POUR COMMANDER DES PIÈCES DE RECHANGE, VEUILLEZ INDIQUER:

- Le numéro de fabrication de la machine
- Le numéro de la pièce
- La quantité désirée

WHEN ORDERING SERVICE-PARTS, WILL YOU PLEASE MENTION:

- The machine type and serial number
- The part number
- The quantity of parts

BEI DER BESTELLUNG VON ERSATZTEILEN IMMER ANGEBEN:

- Die Seriennummer der Maschine
- Die Nummer des Teiles
- Die gewünschte Stückzahl

NELL'ORDINARE I RICAMBI, SI PREGA DI INDICARE:

- Il tipo ed il numero di serie della macchina
- Il codice del componente
- La quantità desiderata

- Toutes les pièces détachées et sous-ensembles sont à commander au magasin pièces de rechange.
- **Les équipements optionnels (OPT)** ainsi que les **notices d'instructions** sont à commander auprès des **services commerciaux**.

- Service parts and service part assemblies are to be ordered through the spare parts department.
- **Optional equipment (OPT)** and **assembly operator's manuals** should be ordered through the **wholesaler sales department**.

- Bestellungen für Ersatzteile und Baugruppen sind an die Ersatzteilabteilung zu richten.
- **Sonderausrüstungen (OPT)** sowie **Montage- und Betriebsanleitungen**, bestellen Sie bitte bei der **Verkaufsabteilung für Maschinen**.

- I ricambi e i sotto-assiemi devono essere ordinati al Magazzino Ricambi.
- **Le attrezzature opzionali (OPT)** ed i **manuali dell'operatore** devono essere ordinati al **Servizio Commerciale**.

CATALOG./LIST N°HR009ATL

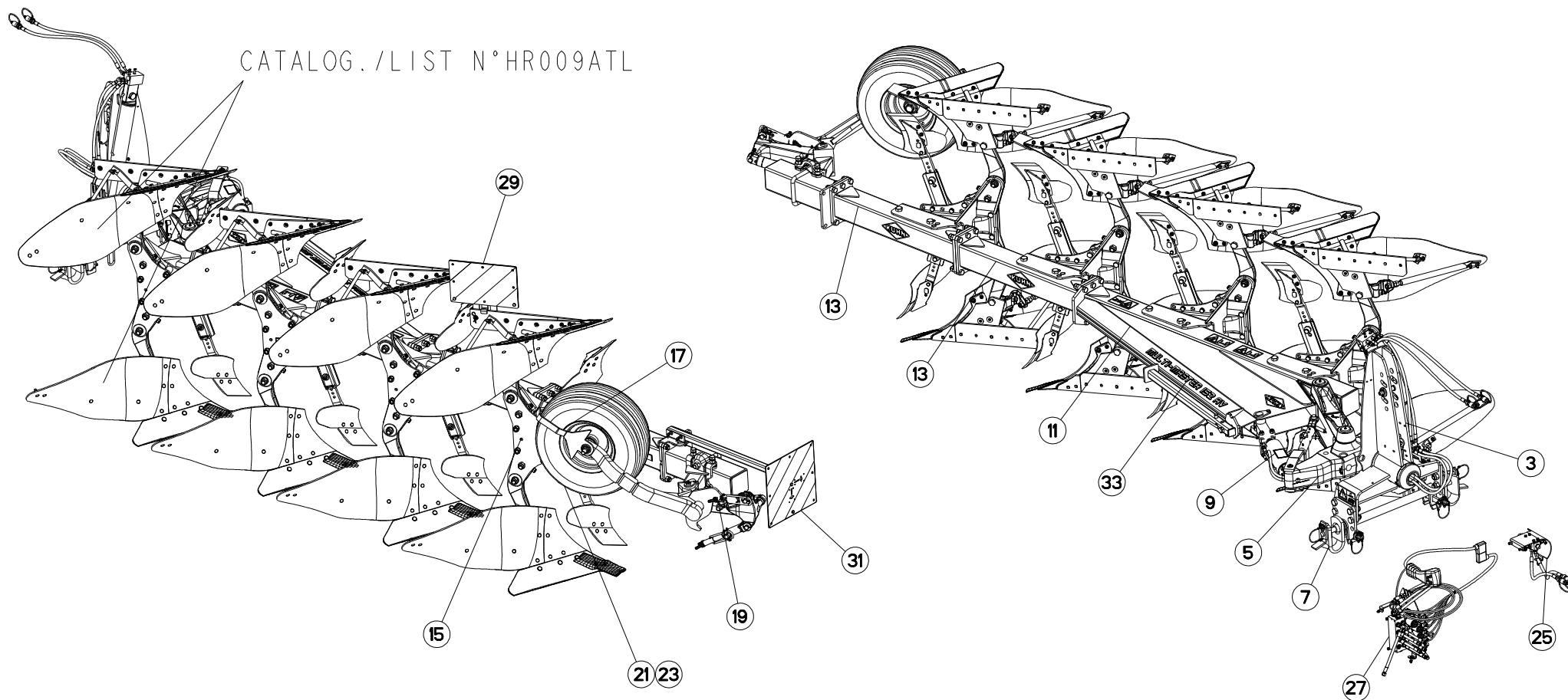



TABLE DES MATIERES - TABLE OF CONTENTS - INHALTSVERZEICHNIS - INDICE

H18R0020 A

Catalogue P.D.R. - Spare parts list - Ersatzteilliste - Pezzi di Ricambio :

HR045CTL B

Annule et remplace - Cancels and replaces - Annulliert und ersetzt - Annulla e sostituisce :

A

Page	Opt	Groupe de pièces	Parts group index	Teilegruppe	Gruppo di parti
003		AVANT-TRAIN B	HEADSTOCK B	PFLUGKOPF B	TESTA DI ROTAZIONE B
005		PARTIE MÉDIANE B MM152 AV	MAIN LINK B MM152 AV	MITTELTEIL B MM152 AV	TIRANTE PRINCIPALE B MM152 AV
007		TRAVERSE STD2 AV	CROSSBAR STD2 AV	QUERTRÄGER STD2 AV	TRAVERSA STD2 AV
009		DEPORT/DEVERS	OFFSETTING ANGLING DEVICE	VORDERFURCHENEINSTELLUNG	SFALSAMENTO/DERIVA
011		BATI 151/2 2ET AV	FRAME 151/2 2ET AV	RAHMEN 151/2 2ET AV	TELAIO 151/2 2ET AV
013		EXTENSION MM152 T AV	EXTENSION MM152 T AV	ERWEITERUNG MM152 T AV	PROLUNGA MM152 T AV
015		AGE SECURITE T80	PLOUGH LEG SAFETY T80	GRINDEL STEINSICHERUN T80	BURE DI SICUREZZA T80
017		BOITIER TIGES RASETTE	SKIMMER LEG/SUPPORT	HALTERUNG/VORSCHALESTIEL	GAMBO DEL PREVOMERE
019	OPT	ROUE DE REGULATION MM152 AV	DEPTH WHEEL MM152 AV	STÜTZRAD MM152 AV	RUOTA DI PROFONDITA MM152 AV
021	OPT	ROUE DE REGULATION Ø690X250 AM	DEPTH WHEEL Ø690X250 DAMPER	STÜTZRAD Ø690X250 STOSSDÄMPFER	RUOTA DI PROFONDITA Ø690X250 A
023	OPT	ROUE DE REGULATION Ø690X320 AM	DEPTH WHEEL Ø690X320 DAMPER	STÜTZRAD Ø690X320 STOSSDÄMPFER	RUOTA DI PROFONDITA Ø690X320 A
025	OPT	ELECTROVANNE	ELEKTROSWITCH	ELEKTROWAHLSCHALTUNG	ELETTROINTERRUTTORE
027	OPT	SELECTEUR ELECTROHYDR.4 FONC.	ELECTROHYDR.SELECTOR 4 FUNC.	ELECTROHYDR.SELECTOR 4 FUNKT.	ELECTROIDRA.SELETTORE 4 FUNZ.
029		SIGNALISATION LATERALE	SIDE SIGNALLING	SEITLICHE WARNTAFELN	SEGNALAZIONE LATERALI
031		SIGNALISATION MM152T AV	SIGNALLING MM152T AV	BELEUCHTUNG U. WARNSCHILDER MM	SEGNALAZIONE MM152T AV
033		COLL.ETIQUETTES ADHESIVES MM15	SET OF STICKERS MM152T AV	SATZ AUFKLEBER MM152T AV	SERIE ADESIVI MM152T AV

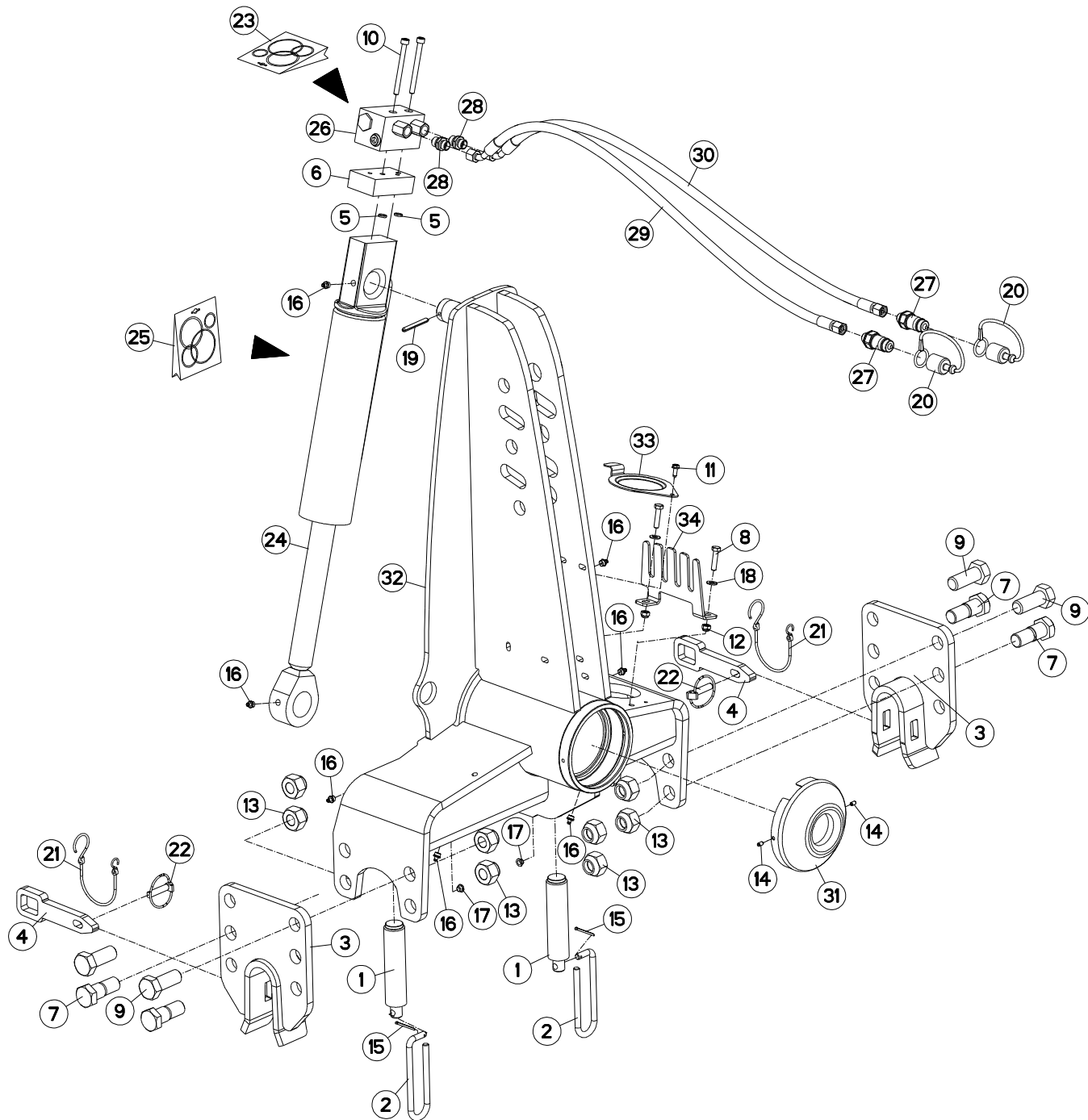



AVANT-TRAIN B

HEADSTOCK B

PFLUGKOPF B

TESTA DI ROTAZIONE B

Rep	Nr	Qt	Designation	Description	Bezeichnung	Referenza	Remarque - Remark - Bemerkung - Osservazioni
001	130126	002	BUTEE/APLOMB D36	LEVELLING ADJUSTER D36	ANSCHLAG D36	PERNO FIL.GROSSO	
002	139108	002	POIGNEE	HANDLE	HANDGRIFF	MANIGLIA	
003	582754	002	MAIN	HAND (B)	ANHAENGUNG (B)	SUPPORTO BARRA	
004	750091	002	VERROU DE TRAVERSE	LOCK	TRAGACHSERIEGEL	FERMO(30X15) D&G X TRAVERSA	
005	900142	002	BAGUE R8/BASE 900473-951129	RING R 8	RING R 8	BOCCOLA	
006	951776	001	BLOC HYDRAULIQUE	MANIFOLD, HYDRAULIC	HYDRAULIK-STUEBERBLOCK	BLOCCO IDRAULICO	
007	970108	004	VIS	SCREW	SCHRAUBE	VITE	
008	80060834	002	VIS TETE HEXAGONALE FE/ZNXC3	HEXAGON HEAD SCREW FE/ZNXC3	SECHSKANTSCHRAUBE FE/ZNXC3	VITE TESTA ESAGONALE FE/ZNXC3	
009	80062461	004	VIS TETE HEXAGONALE FE/ZNXC3	HEXAGON HEAD SCREW FE/ZNXC3	SECHSKANTSCHRAUBE FE/ZNXC3	VITE TESTA ESAGONALE FE/ZNXC3	
010	80080890	002	VIS TETE CYL.SIX P.CR.FE/ZNXC3	HEX.SOCK.HEAD CAP SCR.FE/ZNXC3	ZYLINDERSCHR.INNENSEC.FE/ZNXC3	VITE A TESTA CILINDR. FE/ZNXC3	
011	80190616	001	VIS AUTOTARAU.FE/ZNXC3 TAPTITE	SELF-CUTTING SCREW FE/ZNXC3	GEWINDE-SCHNEIDSCHRAU.FE/ZNXC3	BULLONE FE/ZNXC3	
012	80200830	002	ECROU HEX.AUTOFREINE FE/ZNXC3	SELF-LOCKING NUT FE/ZNXC3	SELBSTSICHERNDE MUTT.FE/ZNXC3	DADO AUTOBLOCCANTE FE/ZNXC3	
013	80202447	008	ECROU HEXAGONAL AUTOFREINE	SELF-LOCKING NUT	SELBSTSICHERNDE MUTTER	DADO AUTOBLOCCANTE	
014	80450610	002	GOUPILLE ELASTIQUE FLZNNC	ROLL PIN FLZNNC	SPANNHUELSE FLZNNC	SPINA ELASTICA FLZNNC	
015	80500236	002	GOUPILLE FENDUE	SPLIT PIN	SPLINT	COPPGLIA	
016	82201016	007	GRAISSEUR AUTOTARAUDANT	SELF TAPPING GREASE NIPPLE	GEWINDESCHNEID-SCHMIERNIPPEL	INGRASSATORE	
017	83040197	002	BOUCHON D'OBTURATION	CONICAL END PLUG	KEGELSTOPFEN	TAPPO DI CHIUSURA	
018	80250917	002	RONDELLE PLATE FE/ZNXC3	PLAIN WASHER FE/ZNXC3	SCHEIBE FE/ZNXC3	RONDELLA PIATTA FE/ZNXC3	
019	80450762	001	GOUPILLE ELASTIQUE FLZNNC	ROLL PIN FLZNNC	SPANNHUELSE FLZNNC	SPINA ELASTICA FLZNNC	
020	82300026	002	CAPUCHON COUPLEUR MALE	CAP MALE CONNECTOR	KAPPE KUPPLUNGSSTECKER	TAPPO	
021	83070064	002	LIEN PVC	PVC CORD	SICHERUNGSBAND	CAVO	
022	900210	002	GOUPILLE DE SECURITE D 11,50	LYNCH PIN D11,50	KLAPPSTECKER D 11,50	SPINA DI SICUREZZA	
023	951832	001	KIT PR CLAPET ANTI-RET COURT	NON RETURN VALVE	RUECKSCHLAGVENTIL	SERIE RIPARAZ.VALVOLA	: 951753
024	951131	001	VERIN NU RETOUR.40X80 C278	TURNOVER CYLINDER	DREHZYLINDER B	MARTINETTO	
025	951200	001	POCH.JOINTS (951127/8/951177)	SEALS PACKET (951127/8/951177)	DICHTSATZ FUER 951127/28/77	SERIE GUARNIZIONI	: 951131
026	H0102170	001	BLOC	BLOCK	BLOCK	BLOCCO	
027	A4074017	002	COUPLEUR MALE	CONNECTOR MALE	KUPPLUNGSTECKER	INNESTO M16X150	
028	A4080401	002	UNION MALE	MALE STUD CONNECTOR	GERADER EINSCHRAUBSTUTZEN	GIUZIONE DIRITTA ZBC	
029	A4921115	001	FLEXIBLE HYDRAULIQUE	HYDRAULIC HOSE	HYDRAULIKSCHLAUCH	TUBO GOMMA	<->1600 mm
030	A4921115	001	FLEXIBLE HYDRAULIQUE	HYDRAULIC HOSE	HYDRAULIKSCHLAUCH	TUBO GOMMA	<->1600 mm
031	H0101450	001	PROTECTEUR	GUARD	SCHUTZ	PROTEZIONE	
032	H0101500	001	POTENCE	BOOM	TRAGARM	ATTACCO ATTREZZO	
033	H0600650	001	COUVERCLE	LID	DECKEL	COPERCHIO	
034	H0601480	001	RATELIER	RACK	GESTELL	CREMAGLIERA	

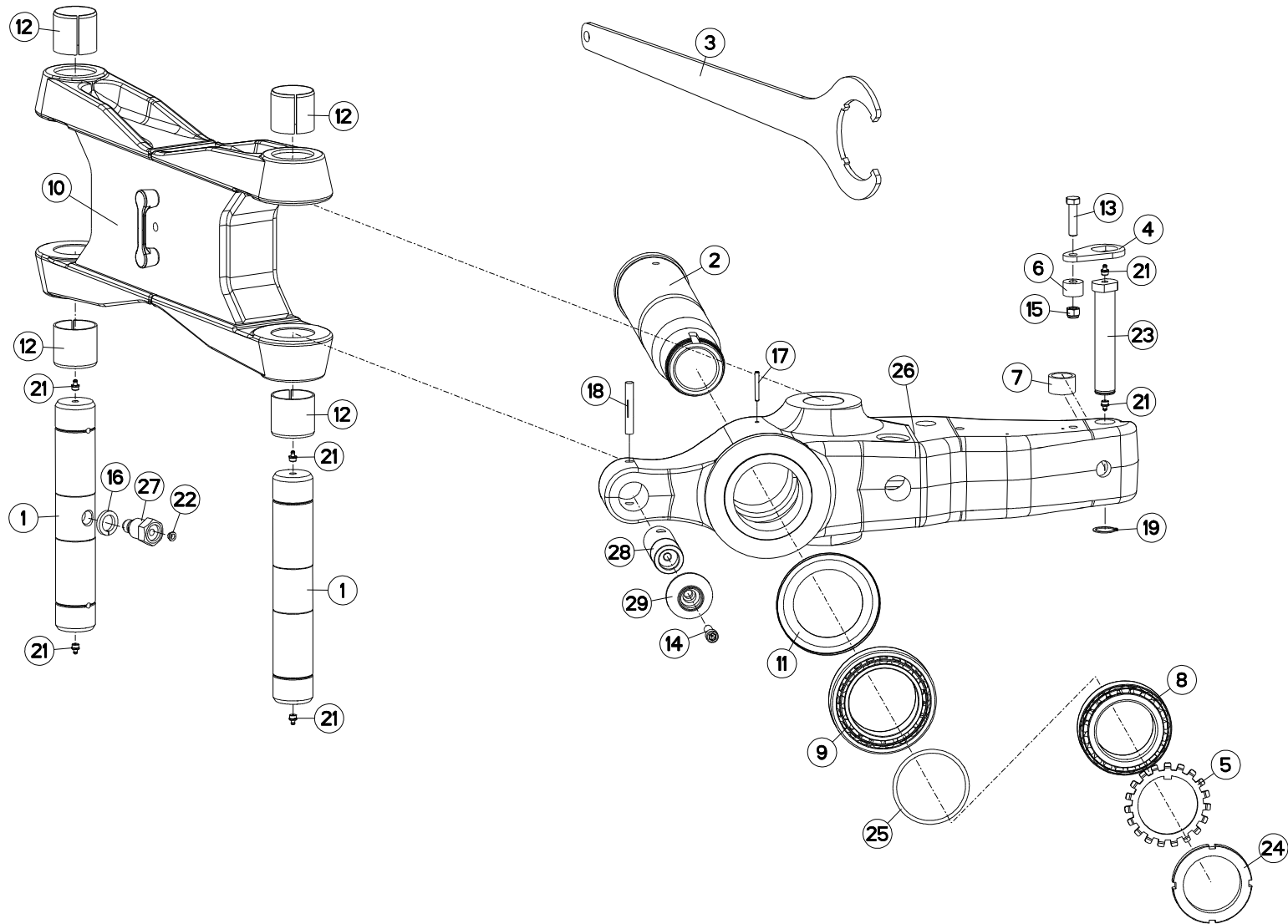



PARTIE MÉDIANE B MM152 AV

MAIN LINK B MM152 AV

MITTELTEIL B MM152 AV

TIRANTE PRINCIPALE B MM152 AV

Rep	Nr	Qt	Designation	Description	Bezeichnung	Referenza	Remarque - Remark - Bemerkung - Osservazioni
001	131251	002	AXE	PIN	ACHSE	ASSE	
002	157146	001	FUSEE	TURNOVER SHAFT	DREHZAPFEN	FUSO	
003	211829	001	CLE SPECIALE	SPANNER	SCHLUESSEL	CHIAVE	: 951115
004	212239	001	PLAQUETTE ARRETOIR	STOP PLATE	ARRETIERUNGSBLECH	PLACHETTA	
005	421191	001	RONDELLE FREIN	LOCK WASHER	SPANNSCHEIBE	RONDELLA	
006	421212	001	ENTRETOISE EP 20,25	SPACER	DISTANZSCHEIBE	DISTANZIATORE	
007	421213	001	ENTRETOISE VERIN	SPACER	DISTANZSCHEIBE	BOCCOLA	
008	81309001	001	ROULEMENT A ROULEAUX CONIQUES	TAPERED ROLLER BEARING	KEGELROLLENLAGER	CUSCINETTO A RULLI CR	
009	490102	001	ROULEMT.RLX CON 105X160X35	BEARING, ROLLER	ROLLENLAGER	CUSCINETTO	
010	582693	001	BIELLE	LINK, CONNECTING	LENKER	BIELLA	
011	951118	001	RONDELLE D'ETANCHEITE	PROTECTOR	SCHIEBE	ANELLO	
012	951521	004	BAGUE ELASTIQUE	TENSION BUSH	EINSPANNBUECHSE	SPINA ELASTICA	
013	80061211	001	VIS TETE HEXAGONALE FLZNNC	HEXAGON HEAD SCREW FLZNNC	SECHSKANTSCHRAUBE FLZNNC	VITE TESTA ESAGONALE FLZNNC	
014	80081240	001	VIS TETE CYL.SIX P.CREUX	HEX.SOCKET HEAD CAP SCREW	ZYLINDERSCHR.INNENSECHSK.	VITE A TESTA CILINDRICA	
015	80201230	001	ECROU HEX.AUTOFREINE FE/ZNXC3	SELF-LOCKING NUT FE/ZNXC3	SELBSTSICH.MUTTER FE/ZNXC3	DADO AUTOBLOCCANTE FE/ZNXC3	
016	80272484	002	RONDELLE GROWER	SPRING LOCK WASHER	FEDERRING	RONDELLA	
017	80450645	001	GOUPILLE ELASTIQUE FLZNNC	ROLL PIN FLZNNC	SPANNHUELSE FLZNNC	SPINA ELASTICA FLZNNC	
018	80541280	001	GOUPILLE CANNELEE	GROOVED PIN	KERBSTIFT	COPPIGLIA	
019	80583000	001	CIRCLIP EXTERIEUR	RETAINING RING	SICHERUNGSRING	ANELLO	
020	82201002	001	GRAISSEUR	GREASE NIPPLE	SCHMIERNIPPEL	INGRASSATORE	
021	82201016	006	GRAISSEUR AUTOTARAUDANT	SELF TAPPING GREASE NIPPLE	GEWINDESCHNEID-SCHMIERNIPPEL	INGRASSATORE	
022	83040197	001	BOUCHON D'OBTURATION	CONICAL END PLUG	KEGELSTOPFEN	TAPPO DI CHIUSURA	
023	720030	001	AXE	PIN	ACHSE	ASSE	
024	951115	001	ECROU A ENCOCHES	SLOTTED ROUND NUT	NUTMUTTER	GHIERA	60daNm 442,54lbf.ft
025	951730	001	JOINT TORIQUE OR 104,2X5,7	SEAL	DICHTUNGSRING	ANELLO	
026	H0100800	001	SUPPORT	SUPPORT	TRAEGER	SUPPORTO	
027	H0301390	002	VIS	SCREW	SCHRAUBE	VITE	
028	H0301460	001	TOURILLON	PIN	BOLZEN	PERNO	
029	H0301470	001	TOURILLON	PIN	BOLZEN	PERNO	

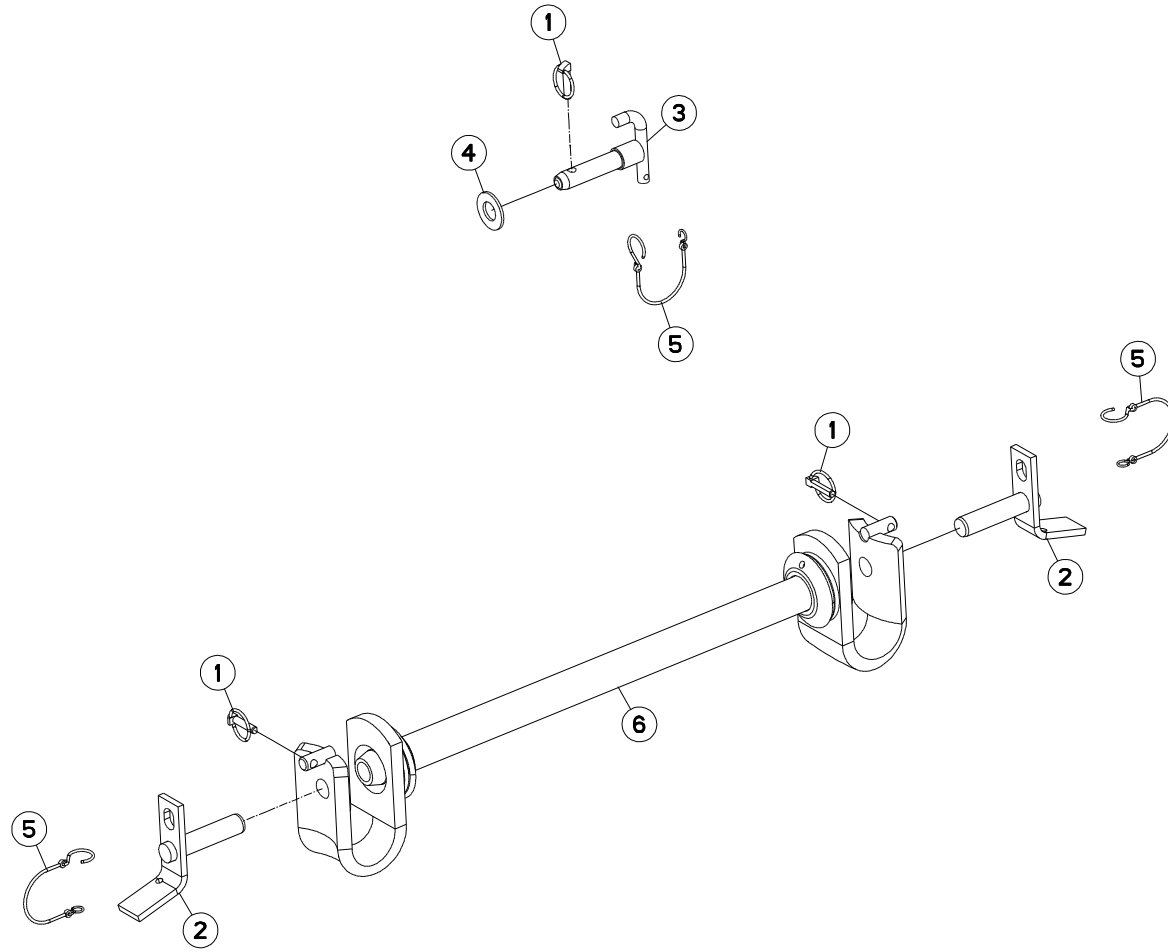



MULTI-MASTER 152 T A

J8584 > K9999

H01R0100 A

TRAVERSE STD2 AV

CROSSBAR STD2 AV

QUERTRÄGER STD2 AV

TRAVERSA STD2 AV

Rep	Nr	Qt	Designation	Description	Bezeichnung	Referenza	Remarque - Remark - Bemerkung - Osservazioni
001	541001	003	GOUPILLE RAPIDE	LYNCH PIN D10 CAT2	KLAPPSTECKER D10 KAT2	CAPPIGLIA	
002	580220	002	BROCHE	PIN, HITCH	ACHSE	PERNO	
003	580296	001	AXE 3 POINT STANDARD 2 D25	TOP LINK PIN CAT2	OBERLENKERBOLZEN KAT 2	PERNO 3 PUNTI STANDARD 2	
004	80252755	001	RONDELLE PLATE FE/ZNXC3	PLAIN WASHER FE/ZNXC3	SCHEIBE FE/ZNXC3	RONDELLA PIATTA FE/ZNXC3	
005	83070064	003	LIEN PVC	PVC CORD	SICHERUNGSBAND	CAVO	
006	H0101040	001	TRAVERSE	TUBE, CROSS	QUERTRAEGER	TRAVERSA	

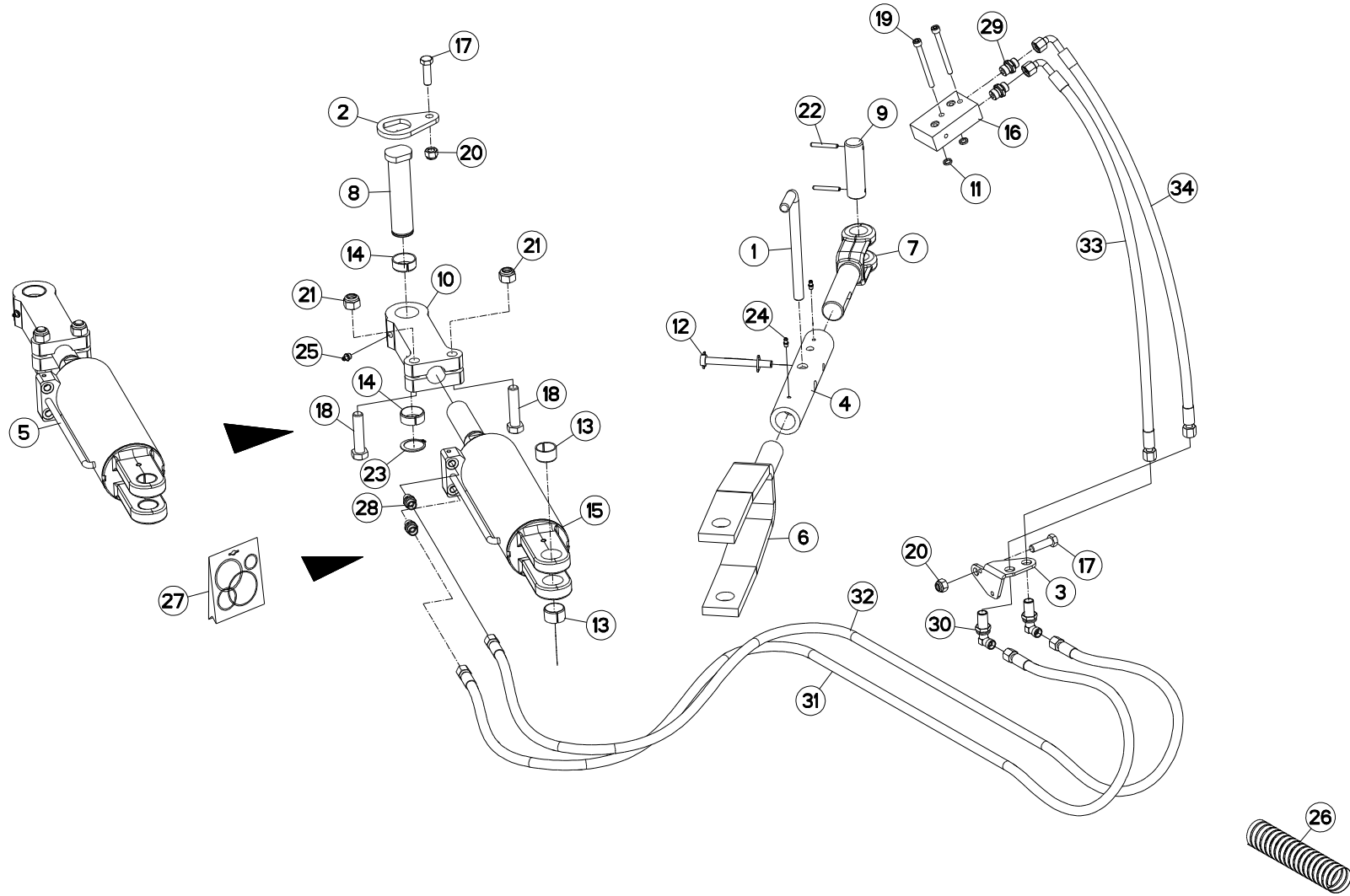



DEPORT/DEVERS

OFFSETTING ANGLING DEVICE

VORDERFURCHENEINSTELLUNG

SFALSAMENTO/DERIVA

Rep	Nr	Qt	Designation	Description	Bezeichnung	Referenza	Remarque - Remark - Bemerkung - Osservazioni
001	139046	001	BROCHE	PIN, HITCH	ACHSE	PERNO	
002	212237	001	PLAQUETTE ARRETOIR	STOP PLATE	ARRETIERUNGSBLECH	PLACHETTA	
003	227113	001	SUPPORT PASSE CLOISON	BRACKET	HALTERUNG	SUPPORTO	
004	445676	001	TUBE	TUBE	ROHR	TUBO	
005	500343	001	VERIN HYDRAULIQUE	CYLINDER, HYDRAULIC	HYDRAULIKZYLINDER	CILINDRO	
006	582692	001	TIRANT	TIE ROD	ZUGSTANGE	TIRANTE	
007	645297	001	TIRANT	TIE ROD	ZUGSTANGE	TIRANTE	
008	720029	001	AXE	PIN	ACHSE	ASSE	
009	720031	001	AXE	PIN	ACHSE	ASSE	
010	750047	001	EMBOUT	END PIECE	ENDSTUECK	GIUNTO	
011	900142	002	BAGUE R8/BASE 900473-951129	RING R 8	RING R 8	BOCCOLA	
012	920136	001	GOUPILLE CAVALIERE FE/ZNXC3	TUBE PIN FE/ZNXC3	ROHRKLAPPSTECKER FE/ZNXC3	PERNO FE/ZNXC3	
013	951522	002	BAGUE	BUSHING	HUELSE	BOCCOLA	
014	951523	002	BAGUE ELASTIQUE	TENSION BUSH	EINSPANNBUECHSE	SPINA ELASTICA	
015	951751	001	VERIN HYDRAULIQUE	CYLINDER, HYDRAULIC	HYDRAULIKZYLINDER	CILINDRO	
016	951776	001	BLOC HYDRAULIQUE	MANIFOLD, HYDRAULIC	HYDRAULIK-STEUERBLOCK	BLOCCO IDRAULICO	
017	80061248	002	VIS TETE HEXAGONALE FE/ZNXC3	HEXAGON HEAD SCREW FE/ZNXC3	SECHSKANTSCHRAUBE FE/ZNXC3	VITE TESTA ESAGONALE FE/ZNXC3	
018	80061637	002	VIS TETE HEXAGONALE FLZNNC	HEXAGON HEAD SCREW FLZNNC	SECHSKANTSCHRAUBE FLZNNC	VITE TESTA ESAGONALE FLZNNC	
019	80080890	002	VIS TETE CYL.SIX P.CR.FE/ZNXC3	HEX.SOCK.HEAD CAP SCR.FE/ZNXC3	ZYLINDERSCHR.INNENSEC.FE/ZNXC3	VITE A TESTA CILINDR. FE/ZNXC3	
020	80201230	002	ECROU HEX.AUTOFREINE FE/ZNXC3	SELF-LOCKING NUT FE/ZNXC3	SELBSTSICH.MUTTER FE/ZNXC3	DADO AUTOBLOCCANTE FE/ZNXC3	
021	80201647	002	ECROU HEX.AUTOFREINE FE/ZNXC3	SELF-LOCKING NUT FE/ZNXC3	SELBSTSICHERNDE MUTT.FE/ZNXC3	DADO AUTOBLOCCANTE FE/ZNXC3	
022	80450645	002	GOUPILLE ELASTIQUE FLZNNC	ROLL PIN FLZNNC	SPANNHUELSE FLZNNC	SPINA ELASTICA FLZNNC	
023	80583500	001	CIRCLIP EXTERIEUR	RETAINING RING	SICHERUNGSRING	ANELLO	
024	82200616	002	GRAISSEUR AUTOTAR.FE/ZNXC3	TAPPING GREASE NIPPLE FE/ZNXC3	GEWINDESCH.SCHMIERNIP.FE/ZNXC3	INGRASSATORE FE/ZNXC3	
025	82201016	001	GRAISSEUR AUTOTARAUDANT	SELF TAPPING GREASE NIPPLE	GEWINDESCHNEID-SCHMIERNIPPEL	INGRASSATORE	
026	900760	001	GAINÉ POLYAMIDE L=1200 RT 25	SHEATH L=1200	HUELLE	GUAINA POLIAMMIDE	
027	929157	001	POCHETTE DE JOINTS	SEALS PACKET (951122)	DICHTSATZ FUER 951122	COLLEZIONE GUARNIZIONI	: 951751
028	A4080400	002	UNION MALE	MALE STUD CONNECTOR	GERADER EINSCHRAUBSTUTZEN	GIUZIONE DIRITTA FEZN/XC3	
029	A4080401	002	UNION MALE	MALE STUD CONNECTOR	GERADER EINSCHRAUBSTUTZEN	GIUZIONE DIRITTA ZBC	
030	A4080750	002	COUDE EGAL / CLOISON NU ZBC	BULKHEAD ELBOW ZBC	WINKEL-SCHOTTVERSCHRAUBUNG ZBC	GIUNZIONE A 90° PASSAPARAT.ZBC	
031	A4921039	001	FLEXIBLE HYDRAULIQUE	HYDRAULIC HOSE	HYDRAULIKSCHLAUCH	TUBO GOMMA	<->2320 mm
032	A4921039	001	FLEXIBLE HYDRAULIQUE	HYDRAULIC HOSE	HYDRAULIKSCHLAUCH	TUBO GOMMA	<->2320 mm
033	A4921070	001	FLEXIBLE HYDRAULIQUE	HYDRAULIC HOSE	HYDRAULIKSCHLAUCH	TUBO GOMMA	<->850 mm
034	A4921070	001	FLEXIBLE HYDRAULIQUE	HYDRAULIC HOSE	HYDRAULIKSCHLAUCH	TUBO GOMMA	<->850 mm

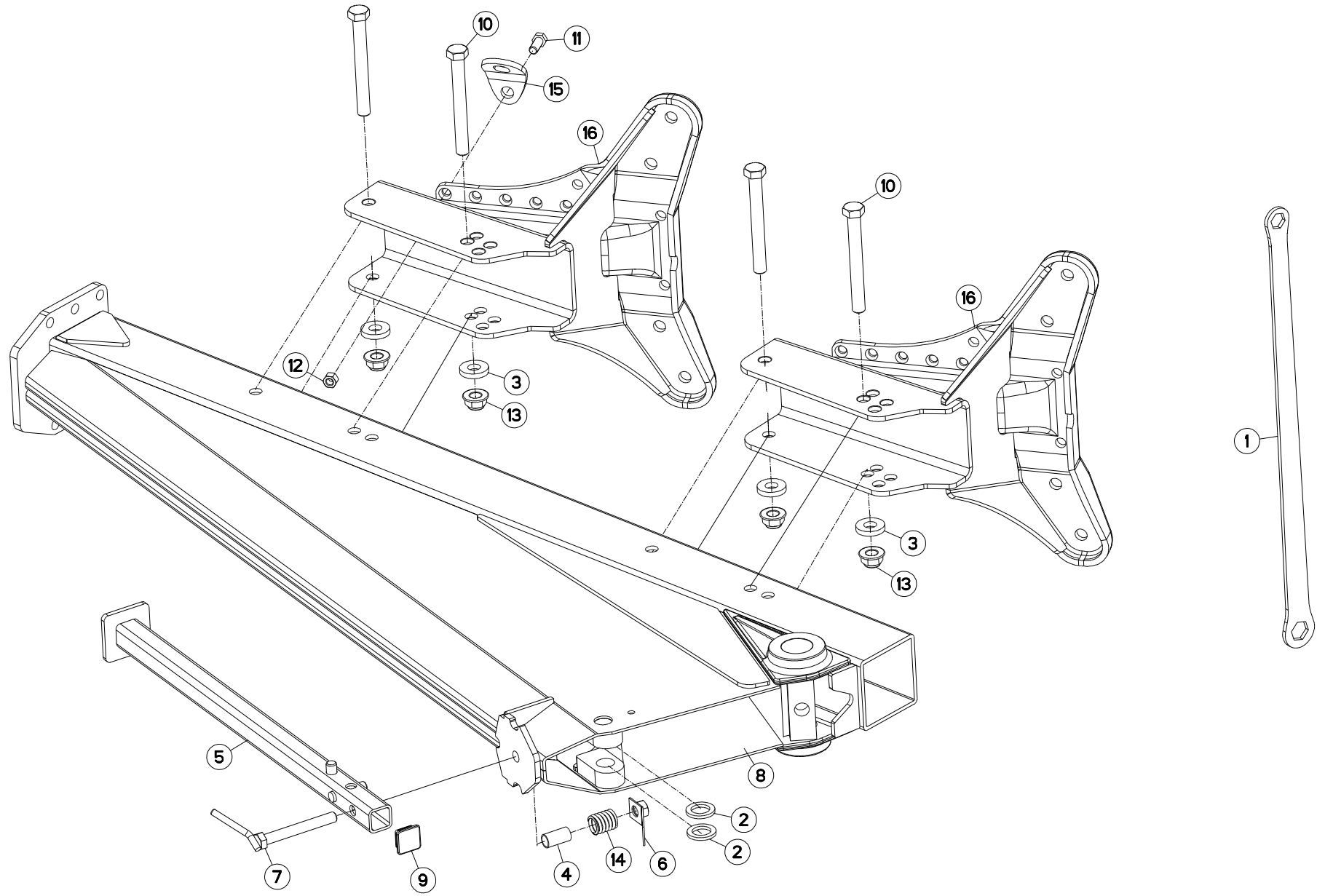



BATI 151/2 2ET AV

FRAME 151/2 2ET AV

RAHMEN 151/2 2ET AV

TELAIO 151/2 2ET AV

Rep	Nr	Qt	Designation	Description	Bezeichnung	Referenza	Remarque - Remark - Bemerkung - Osservazioni
001	211664	001	CLE 30/36	SPANNER 30/36	SCHLUESSEL 30/36	CHIAVE	: 951668
002	421173	002	RONDELLE	WASHER	SCHEIBE	RONDELLA	
003	421223	004	RONDELLE	WASHER	SCHEIBE	RONDELLA	
004	445592	001	ENTRETOISE RESSORT	SPACER	DISTANZSCHEIBE	DISTANZIALE MOLLA	
005	582144	001	BEQUILLE 1600/1700	STANDLEG 75/80	STUETZE 75/80	SUPPORTO	
006	582146	001	PATTE	PLATE	LACHE	FAZZOLETTO	
007	582518	001	AXE DE BRIDAGE	PIN	ACHSE	PERNO	
008	583356	001	BATI	FRAME, MAIN	RAHMEN	TELAIO	
009	A7250558	001	BOUCHON CARRE 50X50X5 NOIR	PLUG	STOPFEN	TAPPO	
010	951668	004	VIS	SCREW	SCHRAUBE	VITE	98daNm 723lbf.ft
011	80061641	001	VIS TETE HEXAGONALE FE/ZNXC3	HEXAGON HEAD SCREW FE/ZNXC3	SECHSKANTSCHRAUBE FE/ZNXC3	VITE TESTA ESAGONALE FE/ZNXC3	
012	80201670	001	ECROU HEXAGONAL FE/ZNXC3	NUT FE/ZNXC3	SECHSKANTMUTTER FE/ZNXC3	DADO FE/ZNXC3	
013	80202421	004	ECROU HEXAG.EMBASE AUTOFR.	SELF-LOCKING NUT	SELBSTSICHERNDE MUTTER	DADO AUTOBLOCCANTE	
014	191042	001	RESSORT DE VERROU	SPRING	FEDER F.VERRIEGELUNG	MOLLA	
015	H0202220	001	DENT	TINE	ZINKEN	DENTE	
016	H0400200	002	BOITIER SUPPORT ETANCON T 150	SUPPORT	GEHAEUSE	SCATOLA	

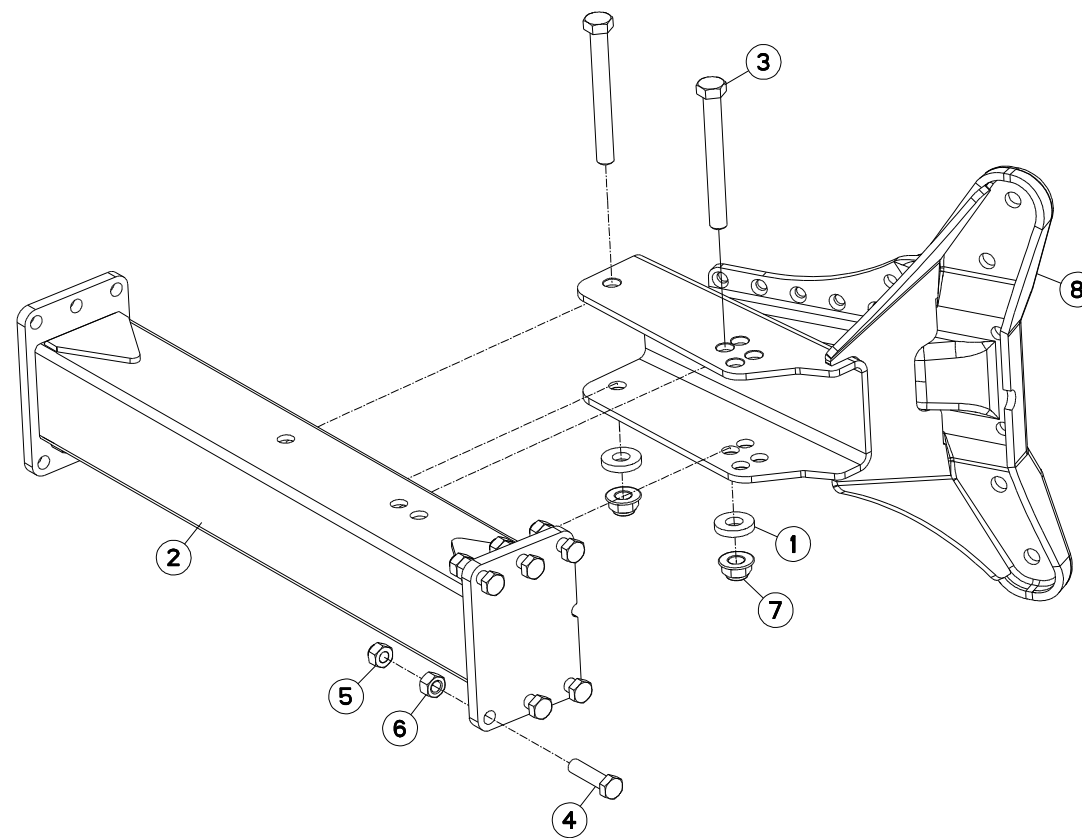



MM1523ET80102A J8584 > K9999
 MM1523ET80102AL J8584 > K9999
 MM1524T80102A J8584 > K9999
 MM1524T80102AL J8584 > K9999

H02R0168 A

EXTENSION MM152 T AV

EXTENSION MM152 T AV

ERWEITERUNG MM152 T AV

PROLUNGA MM152 T AV

Rep	Nr	Qt	Designation	Description	Bezeichnung	Referenza	Remarque - Remark - Bemerkung - Osservazioni
001	421223	002	RONDELLE	WASHER	SCHEIBE	RONDELLA	
002	583368	001	EXTENSION	EXTENSION	ERWEITERUNG	ESTENSIONE	
003	951668	002	VIS	SCREW	SCHRAUBE	VITE	98daNm 723lbf.ft
004	80062068	006	VIS TETE HEXAGONALE FLZNNC	HEXAGON HEAD SCREW FLZNNC	SECHSKANTSCHRAUBE FLZNNC	VITE TESTA ESAGONALE FLZNNC	
005	80202047	006	ECROU HEXAG. AUTOFREINE FLZNNC	SELF-LOCKING NUT FLZNNC	SELBSTSICHERNDE MUTTER FLZNNC	DADO AUTOBLOCCANTE FLZNNC	
006	80202069	006	ECROU HEXAGONAL FE/ZNXC3	NUT FE/ZNXC3	SECHSKANTMUTTER FE/ZNXC3	DADO FE/ZNXC3	
007	80202421	002	ECROU HEXAG.EMBASE AUTOFR.	SELF-LOCKING NUT	SELBSTSICHERNDE MUTTER	DADO AUTOBLOCCANTE	
008	H0400200	001	BOITIER SUPPORT ETANCON T 150	SUPPORT	GEHAEUSE	SCATOLA	

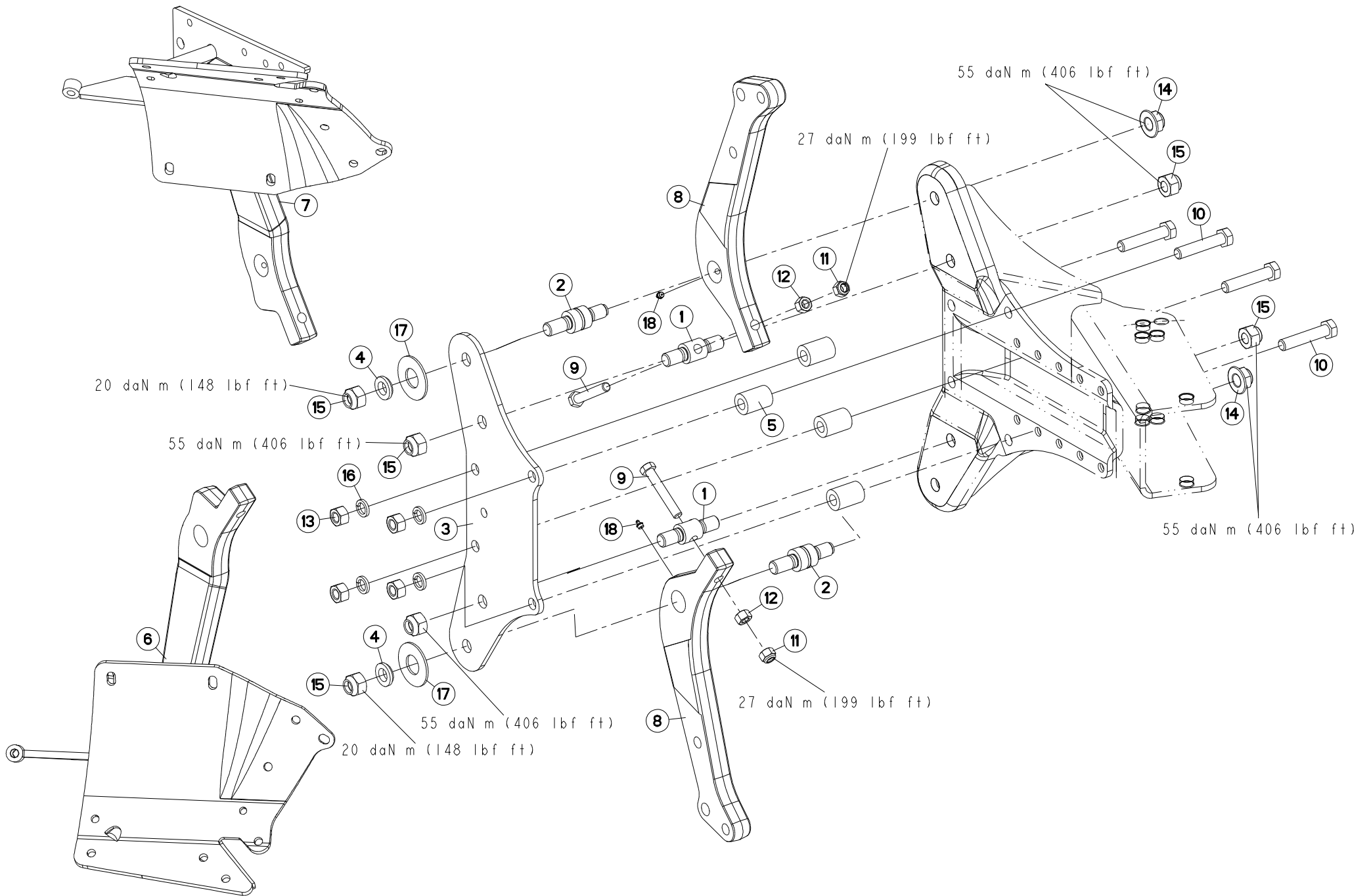



AGE SECURITE T80

PLOUGH LEG SAFETY T80

GRINDEL STEINSICHERUN T80

BURE DI SICUREZZA T80

Rep	Nr	Qt	Designation	Description	Bezeichnung	Referenza	Remarque - Remark - Bemerkung - Osservazioni
001	130147	002	NOIX/SECU.	SPINDLE	KNEBELMUTTER	PERNO	
002	130246	002	AXE D40	PIN D40	ACHSE D40	PERNO D40	
003	211604	001	FLASQUE 8 TROUS	MOULDING	KURBEL WANGE	FLANGIA	
004	421183	002	RONDELLE EPAULEE D.35 EP.10	WASHER WITH SHOULDER	BUCHSE	RONDELLA	
005	445424	004	ENTRETOISE MAST.120/150	SPACER	DISTANZSCHEIBE	BOCCOLA	
006	582196	001	SEP ETANCON T LOSANGE D	T DIAMOND FROG-LEG R	T RAUTEN HALTESTIEL R	GAMBA T LOSANGA DX	
007	582197	001	SEP ETANCON T LOSANGE G	T DIAMOND FROG-LEG L	T RAUTEN HALTESTIEL L	GAMBA T LOSANGA SX	
008	645280	002	ETANCON	SHANK	TRAGRAHMEN	TELAIO	
009	80061681	002	VIS TETE HEXAGONALE FLZNNC	HEXAGON HEAD SCREW FLZNNC	SECHSKANTSCHRAUBE FLZNNC	VITE TESTA ESAGONALE FLZNNC	27daNm 199lbf.ft
010	80062076	004	VIS TETE HEXAGONALE FE/ZNXC3	HEXAGON HEAD SCREW FE/ZNXC3	SECHSKANTSCHRAUBE FE/ZNXC3	VITE TESTA ESAGONALE FE/ZNXC3	
011	80201630	002	ECROU HEX.AUTOFREINE FE/ZNXC3	SELF-LOCKING NUT FE/ZNXC3	SELBSTSICH.MUTTER FE/ZNXC3	DADO AUTOBLOCCANTE FE/ZNXC3	
012	80201669	002	ECROU HEXAGONAL FE/ZNXC3	NUT FE/ZNXC3	SECHSKANTMUTTER FE/ZNXC3	DADO FE/ZNXC3	
013	80202070	004	ECROU HEXAGONAL FE/ZNXC3	NUT FE/ZNXC3	SECHSKANTMUTTER FE/ZNXC3	DADO FE/ZNXC3	
014	80202420	002	ECROU HEXAG.EMBA.AUOFR.FLZNNC	SELF-LOCKING NUT FLZNNC	SELBSTSICHERNDE MUTTER FLZNNC	DADO AUTOBLOCCANTE FLZNNC	
015	80202447	006	ECROU HEXAGONAL AUTOFREINE	SELF-LOCKING NUT	SELBSTSICHERNDE MUTTER	DADO AUTOBLOCCANTE	
016	80272085	004	RONDELLE GROWER FE/ZNXC3	SPRING LOCK WASHER FE/ZNXC3	FEDERRING FE/ZNXC3	RONDELLA GROWER FE/ZNXC3	
017	80283680	002	RONDELLE RESSORT	DISC SPRING	TELLERFEDER	RONDELLA A MOLLA	
018	82201016	002	GRAISSEUR AUTOTARAUDANT	SELF TAPPING GREASE NIPPLE	GEWINDESCHNEID-SCHMIERNIPPEL	INGRASSATORE	

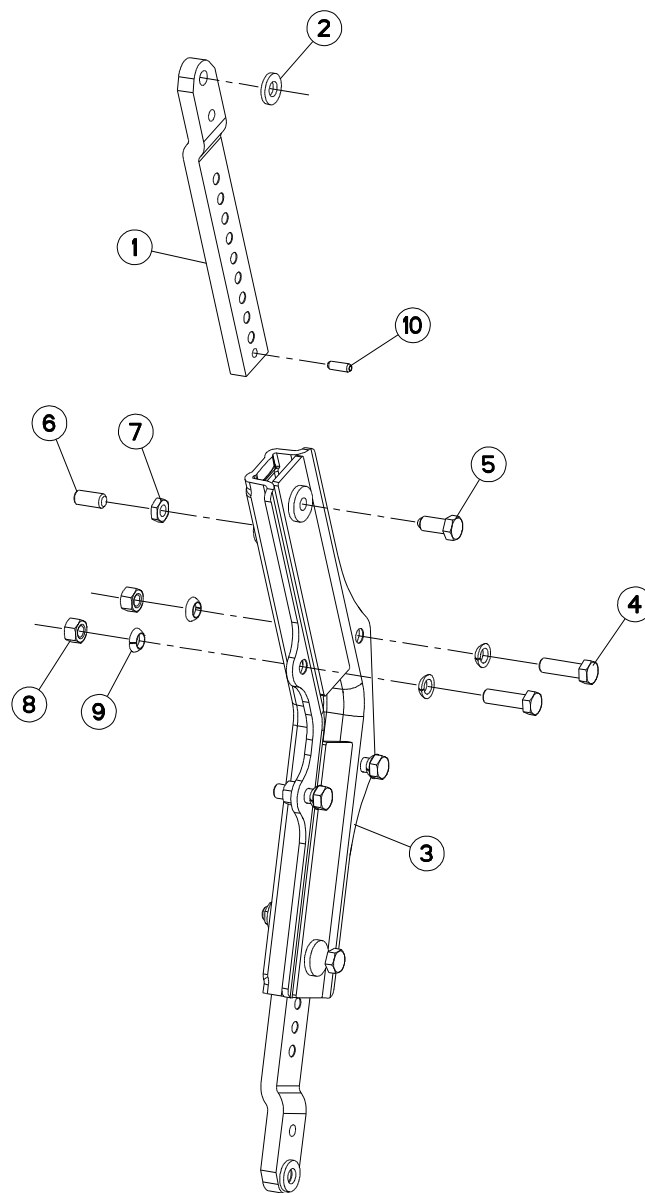



BOITIER TIGES RASETTE

SKIMMER LEG/SUPPORT

HALTERUNG/VORSCHALESTIEL

GAMBO DEL PREVOMERE

Rep	Nr	Qt	Designation	Description	Bezeichnung	Referenza	Remarque - Remark - Bemerkung - Osservazioni
001	261166	002	TIGE DE RASETTE	SKIMMER LEG	STIEL	BRACCIO AVANVOMERE	
002	422069	002	BAGUE 17 X 35 X 5 PLATE ZNB	WASHER	RING	PARAOLIO	
003	582216	001	BOITIER	HOUSING	GEHAEUSE	SCATOLA	
004	80061647	004	VIS TETE HEXAGONALE FE/ZNXC3	HEXAGON HEAD SCREW FE/ZNXC3	SECHSKANTSCHRAUBE FE/ZNXC3	VITE TESTA ESAGONALE FE/ZNXC3	19daNm 140lbf.ft
005	80091640	002	VIS TETE HEX.B.SPHE.FE/ZNXC3	HEXAGON HEAD SCREW FE/ZNXC3	SECHSKANTSCHRAUBE FE/ZNXC3	VITE TESTA ESAGONALE FE/ZNXC3	
006	80151635	002	VIS S/TETE B.PLAT HC FLZNNC	SOCKET SET SCREW FLZNNC	GEWINDESTIFT FLZNNC	VITE FLZNNC	
007	80201601	002	ECROU HEXAGONAL BAS	HEXAGON THIN NUT	FLACHE SECHSKANTMUTTER	DADO	
008	80201670	004	ECROU HEXAGONAL FE/ZNXC3	NUT FE/ZNXC3	SECHSKANTMUTTER FE/ZNXC3	DADO FE/ZNXC3	
009	80271686	008	RONDELLE RESSORT SPHERI.FLZNNC	SPHERICAL SPRING WASHER FLZNNC	FEDERRING FLZNNC	RONDELLA A MOLLA FLZNNC	
010	80450928	002	GOUPILLE ELASTIQUE FLZNNC	ROLL PIN FLZNNC	SPANNHUELSE FLZNNC	SPINA ELASTICA FLZNNC	

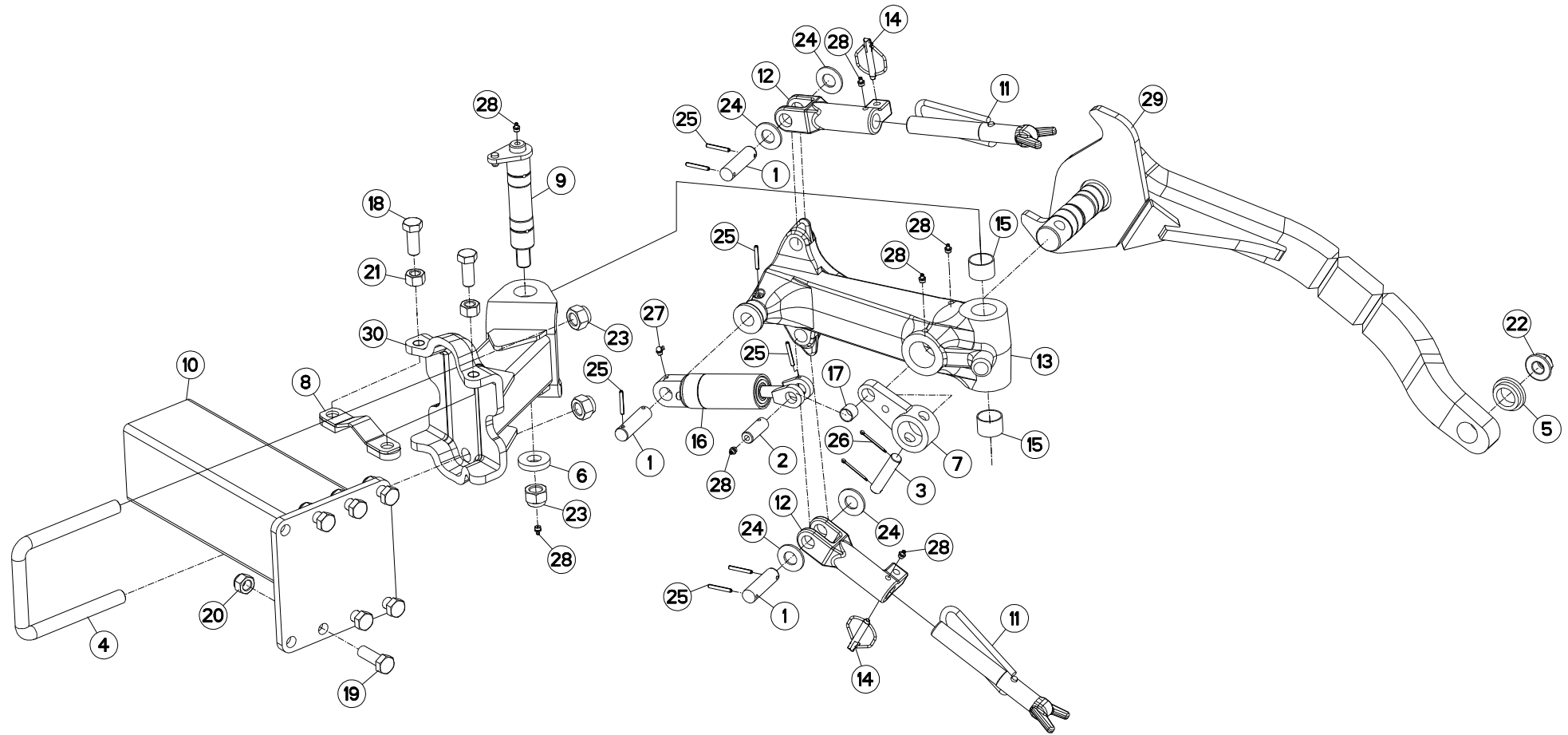



ROUE DE REGULATION MM152 AV

DEPTH WHEEL MM152 AV

STÜTZRAD MM152 AV

RUOTA DI PROFONDITA MM152 AV

Rep	Nr	Qt	Designation	Description	Bezeichnung	Referenza	Remarque - Remark - Bemerkung - Osservazioni
001	130277	003	AXE	PIN	ACHSE	ASSE	
002	130279	001	AXE	PIN	ACHSE	ASSE	
003	130283	001	AXE	PIN	ACHSE	ASSE	
004	148132	001	ETRIER	U-BOLT	BUEGEL	CAVALLOTTO	
005	421221	001	ENTRETOISE	SPACER	DISTANZHUELSE	DISTANZIALE	
006	421223	001	RONDELLE	WASHER	SCHEIBE	RONDELLA	
007	582311	001	BIELLETTE	LINK	SHUBSTANGE	BIELLA	
008	582603	001	CALE	SHIM	DISTANZPLATTE	SPESSORE	
009	582606	001	AXE PIVOT M120/150	AXLE	ACHSE	ASSE M120/150	
010	582715	001	POUTRE SUPP.ROUE	BEAM	RAHMEN	TRAVE	
011	582897	002	VIS COMPLETE	SCREW	SCHRAUBE	VITE	
012	645281	002	SUPPORT BUTEE	BRACKET	HALTERUNG	SUPPORTO	
013	645314	001	SUPPORT	SUPPORT	TRAEGER	SUPPORTO	
014	900788	002	GOUPILLE DE SECURITE	LYNCH PIN	KLAPPSTECKER	COPPIGLIA	
015	951168	002	BAGUE ROULEE	WRAPPED BUSH	GEROLLTE BUCHSE	ANELLO LUBRIFICATO	
016	951460	001	AMORTISSEUR	SHOCK ABSORBER	STOSSDAEMPFER	AMMORTIZZATORE	
017	83012225	001	BAGUE ROULEE	WRAPPED BUSH	GEROLLTE BUCHSE	ANELLO LUBRIFICATO	
018	80062049	002	VIS TETE HEXAGONALE FE/ZNXC3	HEXAGON HEAD SCREW FE/ZNXC3	SECHSKANTSCHRAUBE FE/ZNXC3	VITE TESTA ESAGONALE FE/ZNXC3	
019	80062059	006	VIS TETE HEXAGONALE FE/ZNXC3	HEXAGON HEAD SCREW FE/ZNXC3	SECHSKANTSCHRAUBE FE/ZNXC3	VITE TESTA ESAGONALE FE/ZNXC3	
020	80202030	006	ECROU HEX.AUTOFREINE FE/ZNXC3	SELF-LOCKING NUT FE/ZNXC3	SELBSTSICH.MUTTER FE/ZNXC3	DADO AUTOBLOCCANTE FE/ZNXC3	
021	80202070	002	ECROU HEXAGONAL FE/ZNXC3	NUT FE/ZNXC3	SECHSKANTMUTTER FE/ZNXC3	DADO FE/ZNXC3	
022	80202420	001	ECROU HEXAG.EMBA.AUTOFR.FLZNNC	SELF-LOCKING NUT FLZNNC	SELBSTSICHERNDE MUTTER FLZNNC	DADO AUTOBLOCCANTE FLZNNC	
023	80202440	003	ECROU HEX.AUTOFREINE FE/ZNXC3	SELF-LOCKING NUT FE/ZNXC3	SELBSTSICHERNDE MUTT.FE/ZNXC3	DADO AUTOBLOCCANTE FE/ZNXC3	
024	80252432	004	RONDELLE PLATE FE/ZNXC3	PLAIN WASHER FE/ZNXC3	SCHEIBE FE/ZNXC3	RONDELLA PIATTA FE/ZNXC3	
025	80450645	007	GOUPILLE ELASTIQUE FLZNNC	ROLL PIN FLZNNC	SPANNHUELSE FLZNNC	SPINA ELASTICA FLZNNC	
026	80500345	002	GOUPILLE FENDUE	SPLIT PIN	SPLINT	COPPIGLIA	
027	82200804	001	GRAISSEUR FE/ZNXC3	GREASE NIPPLE FE/ZNXC3	SCHMIERNIPPEL FE/ZNXC3	INGRASSATORE FE/ZNXC3	
028	82201016	007	GRAISSEUR AUTOTARAUDANT	SELF TAPPING GREASE NIPPLE	GEWINDESCHNEID-SCHMIERNIPPEL	INGRASSATORE	
029	H0501070	001	BRAS DE ROUE	ARM, WHEEL	RADARM	BRACCIO PER RUOTA	
030	H0501800	001	SUPPORT	SUPPORT	TRAEGER	SUPPORTO	

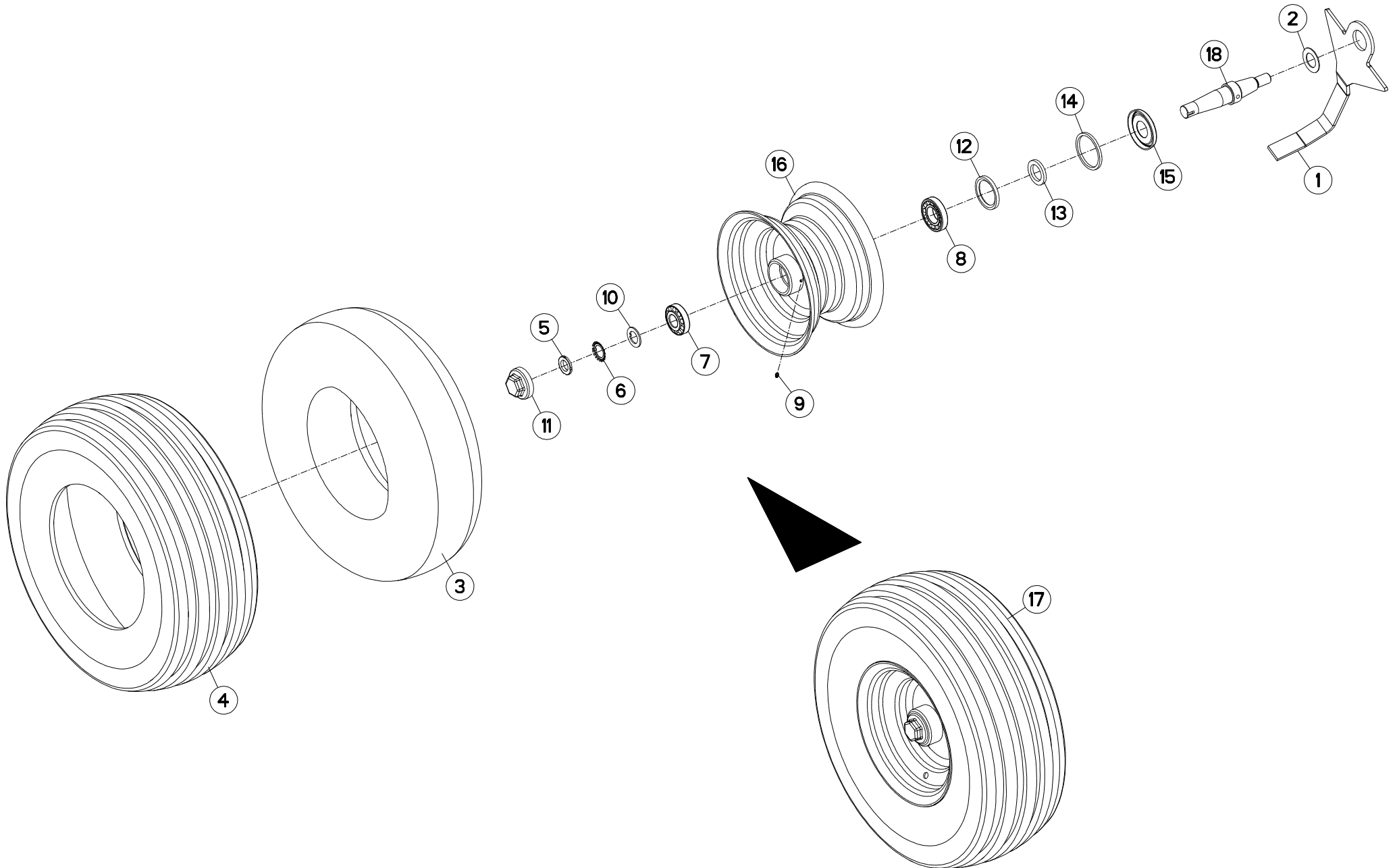



MULTI-MASTER 152 T A

J8584 > K9999

H05R0028 B

ROUE DE REGULATION Ø690X250 AM

DEPTH WHEEL Ø690X250 DAMPER

STÜTZRAD Ø690X250 STOSSDÄMPFER

RUOTA DI PROFONDITA Ø690X250 /

Rep	Nr	Qt	Designation	Description	Bezeichnung	Referenza	Remarque - Remark - Bemerkung - Osservazioni
001	227678	001	DECROTTEUR	SCRAPER, SOIL	ABSTREIFER	RASCHIETTO	
002	421281	001	RONDELLE	WASHER	SCHEIBE	RONDELLA	
003	900155	001	CHAMBRE A AIR ROUE 569124	INNER TUBE WHEEL 569124	SCHLAUCH	CAMERA	
004	900156	001	PNEU 446 10./75-12 10PR	TYRE WHEEL 446 10./75-12 10PR	REIFEN 446 10./75-12 10PR	PNEUMATICO 446 10./75-12 10PR	
005	80203018	001	ECROU A ENCOCHES	SLOTTED ROUND NUT	NUTMUTTER	DADO	
006	80293020	001	RONDELLE-FREIN	TAB WASHER	SICHERUNGSBLECH	RONDELLA-FRENO	
007	81303072	001	ROULEMENT A ROULEAUX CONIQUES	TAPERED ROLLER BEARING	KEGELROLLENLAGER	CUSCINETTO A RULLO	
008	81304079	001	ROULEMENT A ROULEAUX CONIQUES	TAPERED ROLLER BEARING	KEGELROLLENLAGER	CUSCINETTO A RULLO	
009	82200600	001	GRAISSEUR FE/ZNXC3	GREASE NIPPLE FE/ZNXC3	SCHMIERNIPPEL FE/ZNXC3	INGRASSATORE FE/ZNXC3	
010	H0500480	001	RONDELLE FREIN	WASHER	SCHEIBE	RONDELLA	
011	H0500490	001	CHAPEAU A VISSER	CAP	KAPPE	COPERCHIO	
012	H0500500	001	JOINT ETANCHE A L'HUILE	SEAL	DICHTUNG	GUARNIZIONE	
013	H0500510	001	RONDELLE	WASHER	SCHEIBE	RONDELLA	
014	H0500520	001	BAGUE FEUTRE	BUSH	HUELSE	BOCCOLA	
015	H0500530	001	CHAPEAU D'ETANCHEITE	CAP	KAPPE	COPERCHIO	
016	H0500580	001	JANTE ROUE 7.00 X 12 X 4.0	RIM	FELGE	CERCHIO	
017	H0500590	001	ROUE	WHEEL	RAD	RUOTA	6,8 bar (98.6 PSI)
018	H0500910	001	AXE	PIN	ACHSE	ASSE	

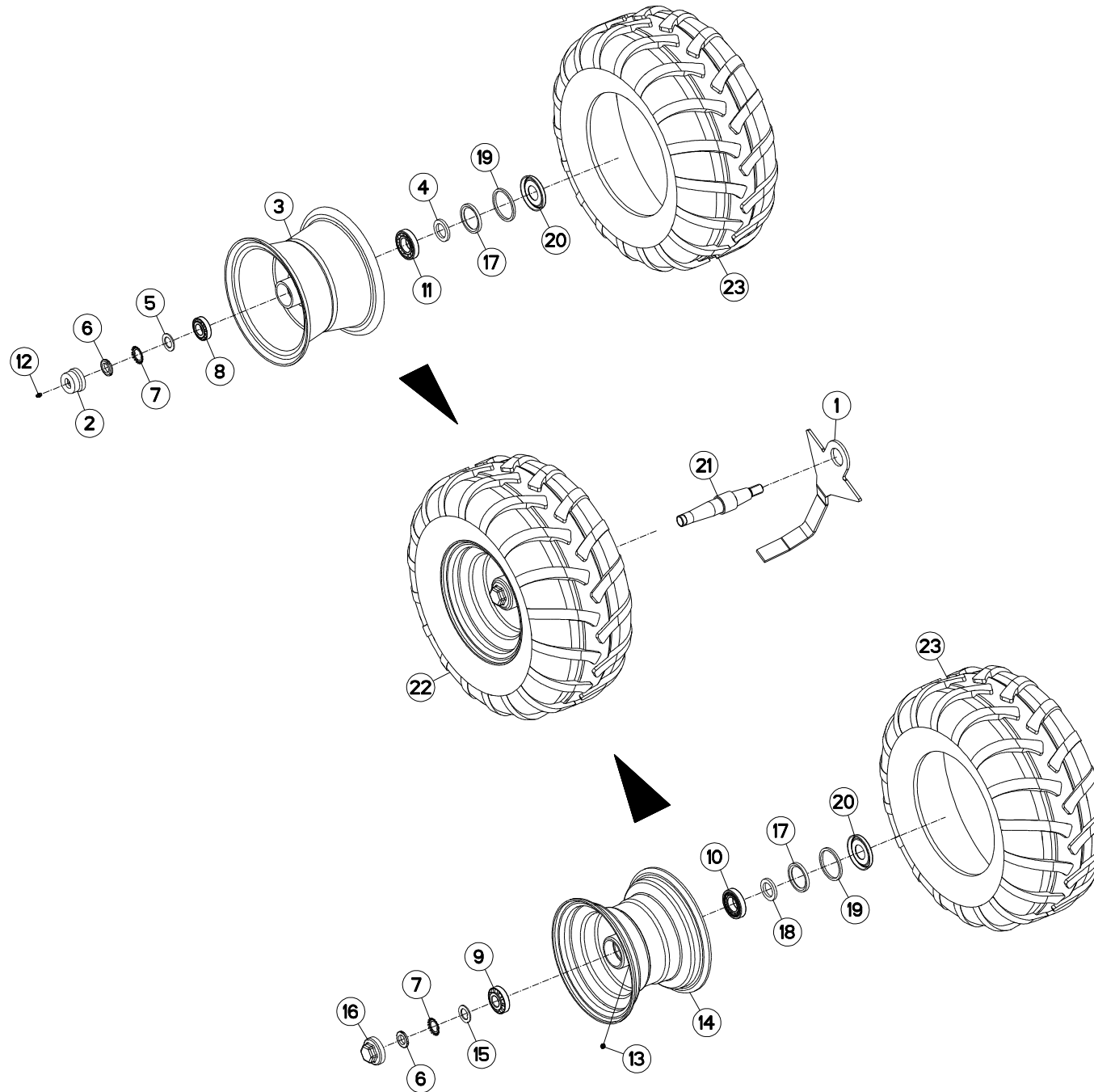



MULTI-MASTER 152 T A

J8584 > K9999

H05R0034 B

ROUE DE REGULATION Ø690X320 AM

DEPTH WHEEL Ø690X320 DAMPER

STÜTZRAD Ø690X320 STOSSDÄMPFER

RUOTA DI PROFONDITA Ø690X320 A

Rep	Nr	Qt	Designation	Description	Bezeichnung	Referenza	Remarque - Remark - Bemerkung - Osservazioni
001	227678	001	DECROTTEUR	SCRAPER, SOIL	ABSTREIFER	RASCHIETTO	
002	900135	001	CAPUCHON AVEC GRAISSEUR	CAP	KAPPE D63 40 M. SCHMIERN.	CAPPUCCIO	
003	900168	001	JANTE D660	WHEEL RIM	FELGE D660	CERCHIO	
004	951204	001	RONDELLE 60X40X7	WASHER	SCHEIBE	RONDELLA	
005	H0500480	001	RONDELLE FREIN	WASHER	SCHEIBE	RONDELLA	
006	80203018	001	ECROU A ENCOCHES	SLOTTED ROUND NUT	NUTMUTTER	DADO	
007	80293020	001	RONDELLE-FREIN	TAB WASHER	SICHERUNGSBLECH	RONDELLA-FRENO	
008	81303062	001	ROULEMENT A ROULEAUX CONIQUES	TAPERED ROLLER BEARING	KEGELROLLENLAGER	CUSCINETTO A RULLO	
009	81303072	001	ROULEMENT A ROULEAUX CONIQUES	TAPERED ROLLER BEARING	KEGELROLLENLAGER	CUSCINETTO A RULLO	
010	81304079	001	ROULEMENT A ROULEAUX CONIQUES	TAPERED ROLLER BEARING	KEGELROLLENLAGER	CUSCINETTO A RULLO	
011	81304079	001	ROULEMENT A ROULEAUX CONIQUES	TAPERED ROLLER BEARING	KEGELROLLENLAGER	CUSCINETTO A RULLO	
012	82200800	001	GRAISSEUR FE/ZNXC3	GREASE NIPPLE FE/ZNXC3	SCHMIERNIPPEL FE/ZNXC3	INGRASSATORE FE/ZNXC3	
013	82201016	001	GRAISSEUR AUTOTARAUDANT	SELF TAPPING GREASE NIPPLE	GEWINDESCHNEID-SCHMIERNIPPEL	INGRASSATORE	
014	H0500440	001	JANTE	WHEEL	FELGE	CERCHIO	
015	H0500480	001	RONDELLE FREIN	WASHER	SCHEIBE	RONDELLA	
016	H0500490	001	CHAPEAU A VISSER	CAP	KAPPE	COPERCHIO	
017	H0500500	001	JOINT ETANCHE A L'HUILE	SEAL	DICHTUNG	GUARNIZIONE	
018	H0500510	001	RONDELLE	WASHER	SCHEIBE	RONDELLA	
019	H0500520	001	BAGUE FEUTRE	BUSH	HUELSE	BOCCOLA	
020	H0500530	001	CHAPEAU D'ETANCHEITE	CAP	KAPPE	COPERCHIO	
021	H0500920	001	AXE	PIN	ACHSE	ASSE	
022	H0501110	001	ROUE	WHEEL AND TIRE ASSEMBLY	RAD	RUOTA	3,2 bar (46,4 PSI)
023	H0501120	001	PNEU	TIRE	REIFEN	PNEUMATICO	

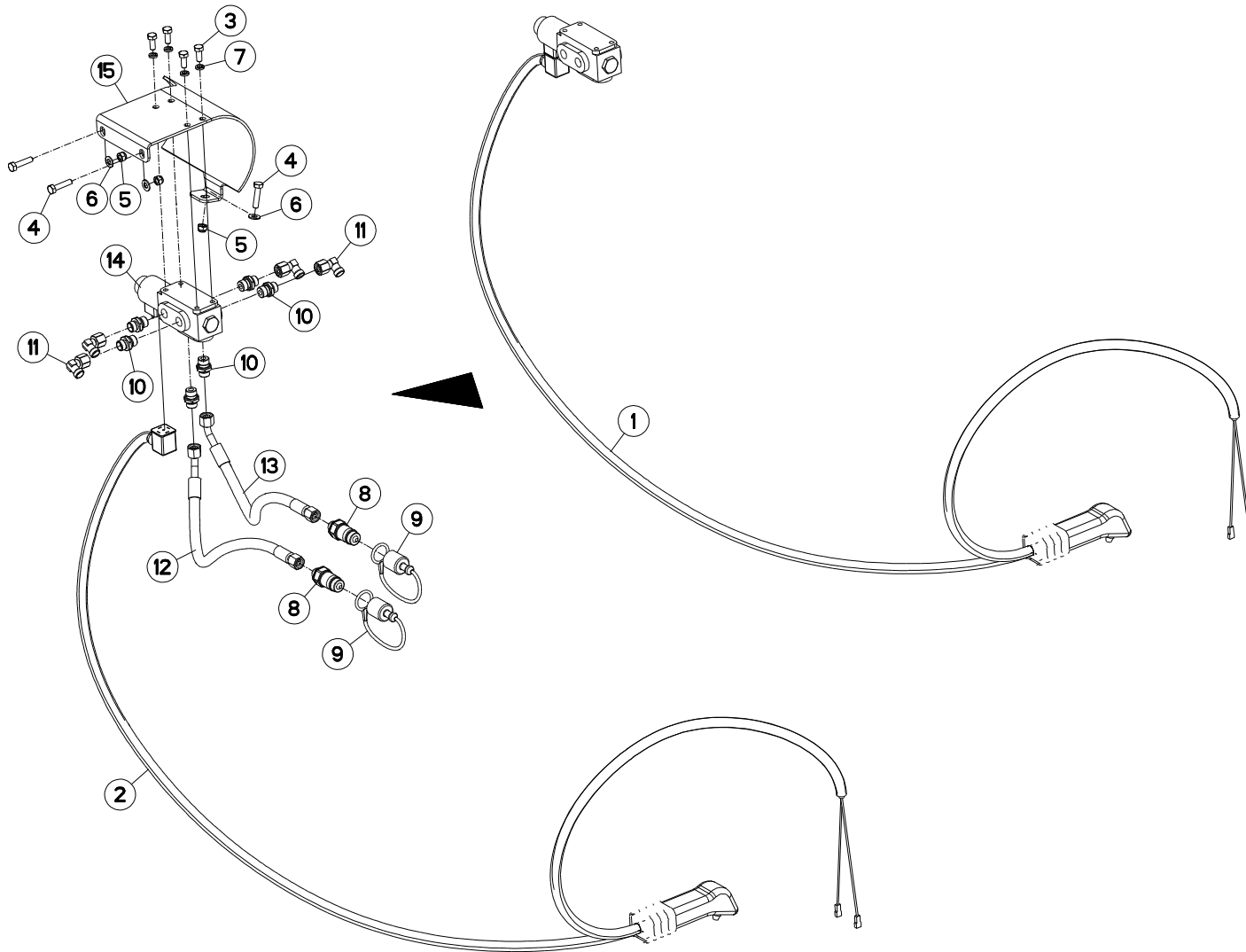



ELECTROVANNE

ELEKTROSWITCH

ELEKTROWAHLSCHALTUNG

ELETTROINTERRUTTORE

Rep	Nr	Qt	Designation	Description	Bezeichnung	Referenza	Remarque - Remark - Bemerkung - Osservazioni
001	951637	001	SELECTEUR + POIGNEE	SELECTOR + HANDEL	WAHLSCHALTVENTIL + HANGRIFF	SELETTORE + MANIGLIA	
002	952251	001	POIGNEE+CABLE SELECTEUR 951637	HANDEL	HANGRIFF	MANIGLIA	
003	80060820	004	VIS TETE HEXAGONALE FE/ZNXC3	HEXAGON HEAD SCREW FE/ZNXC3	SECHSKANTSCHRAUBE FE/ZNXC3	VITE TESTA ESAGONALE FE/ZNXC3	
004	80060834	003	VIS TETE HEXAGONALE FE/ZNXC3	HEXAGON HEAD SCREW FE/ZNXC3	SECHSKANTSCHRAUBE FE/ZNXC3	VITE TESTA ESAGONALE FE/ZNXC3	
005	80200830	003	ECROU HEX.AUTOFREINE FE/ZNXC3	SELF-LOCKING NUT FE/ZNXC3	SELBSTSICHERNDE MUTT.FE/ZNXC3	DADO AUTOBLOCCANTE FE/ZNXC3	
006	80250917	003	RONDELLE PLATE FE/ZNXC3	PLAIN WASHER FE/ZNXC3	SCHEIBE FE/ZNXC3	RONDELLA PIATTA FE/ZNXC3	
007	80270884	004	RONDELLE GROWER	SPRING LOCK WASHER	FEDERRING	RONDELLA GROWER	
008	A4074017	002	COUPLEUR MALE	CONNECTOR MALE	KUPPLUNGSTECKER	INNESTO M16X150	
009	82300026	002	CAPUCHON COUPLEUR MALE	CAP MALE CONNECTOR	KAPPE KUPPLUNGSSTECKER	TAPPO	
010	A4080401	006	UNION MALE	MALE STUD CONNECTOR	GERADER EINSCHRAUBSTUTZEN	GIUNZIONE DIRITTA ZBC	
011	A4082700	004	COUDE TOURNANT	AJUSTABLE MALE STUD ELBOW	EINSTELLBARER WINKELSTUTZEN	GIUNZIONE A 90°ORIENTABILE	
012	A4921115	001	FLEXIBLE HYDRAULIQUE	HYDRAULIC HOSE	HYDRAULIKSCHLAUCH	TUBO GOMMA	<->1600 mm
013	A4921115	001	FLEXIBLE HYDRAULIQUE	HYDRAULIC HOSE	HYDRAULIKSCHLAUCH	TUBO GOMMA	<->1600 mm
014	H0601070	001	ELECTROVANNE	ELECTRIC SHUT-OFF SLIDE	ELEKTROSCHIEBER	ELETTROVALVOLA	
015	H0601510	001	CARTER	HOUSING	GEHAEUSE	SCATOLA	

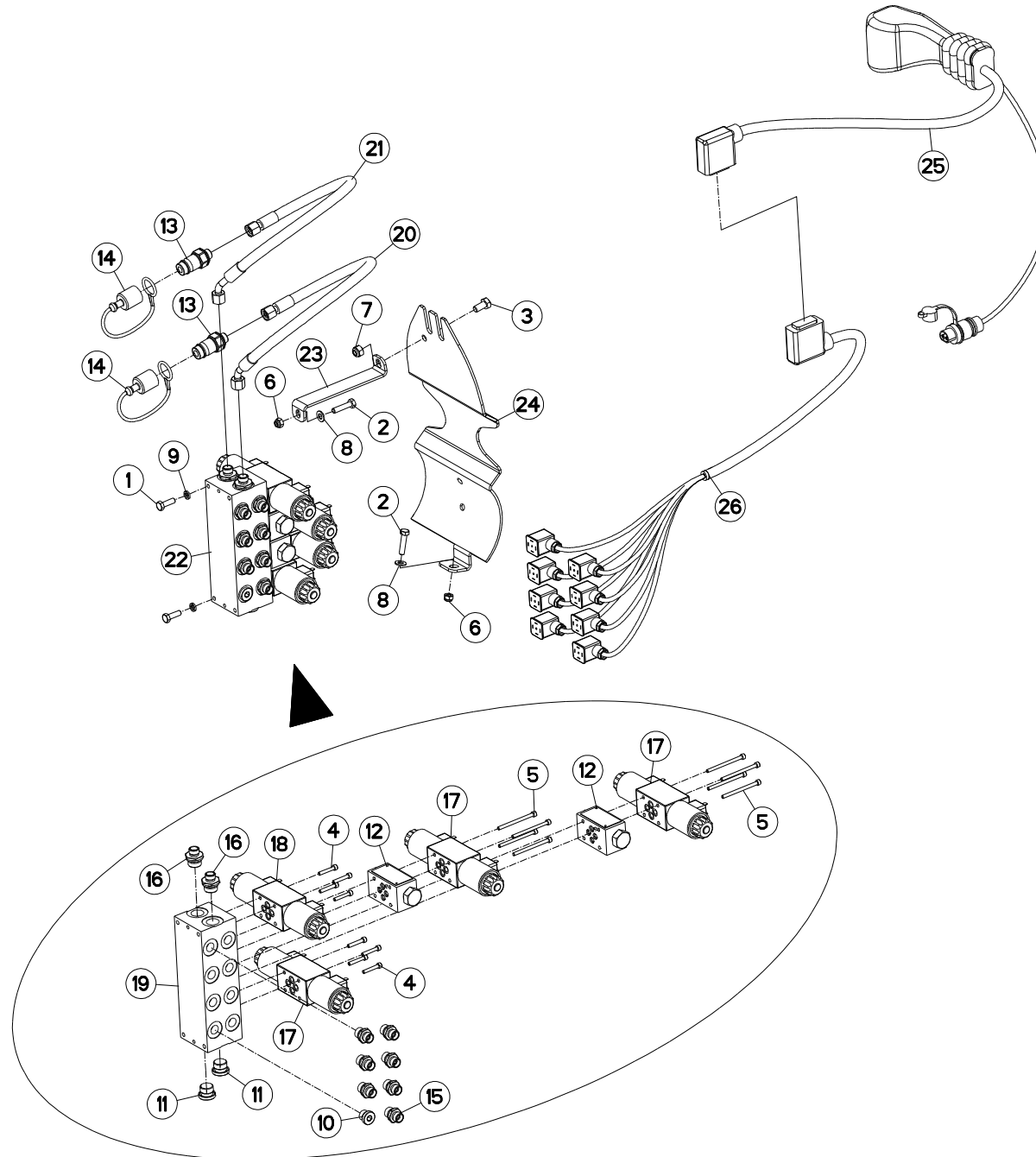



SELECTEUR ELECTROHYDR.4 FONC. ELECTROHYDR.SELECTOR 4 FUNCT. ELECTROHYDR.SELECTOR 4 FUNKT. ELECTROIDRA.SELETTORE 4 FUNZ.

Rep	Nr	Qt	Designation	Description	Bezeichnung	Referenza	Remarque - Remark - Bemerkung - Osservazioni
001	80060826	002	VIS TETE HEXAGONALE FE/ZNXC3	HEXAGON HEAD SCREW FE/ZNXC3	SECHSKANTSCHRAUBE FE/ZNXC3	VITE TESTA ESAGONALE FE/ZNXC3	
002	80060834	002	VIS TETE HEXAGONALE FE/ZNXC3	HEXAGON HEAD SCREW FE/ZNXC3	SECHSKANTSCHRAUBE FE/ZNXC3	VITE TESTA ESAGONALE FE/ZNXC3	
003	80061072	001	VIS TETE HEXAGONALE FE/ZNXC3	HEXAGON HEAD SCREW FE/ZNXC3	SECHSKANTSCHRAUBE FE/ZNXC3	VITE TESTA ESAGONALE FE/ZNXC3	
004	80080530	008	VIS TETE CYL.SIX P.CR.FE/ZNXC3	HEX.SOCK.HEAD CAP SCR.FE/ZNXC3	ZYLINDERSCHR.INNENSEC.FE/ZNXC3	VITE A TESTA CILINDR. FE/ZNXC3	
005	80080570	008	VIS TETE CYL.SIX P.CR.FE/ZNXC3	HEX.SOCK.HEAD CAP SCR.FE/ZNXC3	ZYLINDERSCHR.INNENSEC.FE/ZNXC3	VITE A TESTA CILINDR. FE/ZNXC3	
006	80200830	002	ECROU HEX.AUTOFREINE FE/ZNXC3	SELF-LOCKING NUT FE/ZNXC3	SELBSTSICHERNDE MUTT.FE/ZNXC3	DADO AUTOBLOCCANTE FE/ZNXC3	
007	80201030	001	ECROU HEX.AUTOFREINE FE/ZNXC3	SELF-LOCKING NUT FE/ZNXC3	SELBSTSICH.MUTTER FE/ZNXC3	DADO AUTOBLOCCANTE FE/ZNXC3	
008	80250917	002	RONDELLE PLATE FE/ZNXC3	PLAIN WASHER FE/ZNXC3	SCHEIBE FE/ZNXC3	RONDELLA PIATTA FE/ZNXC3	
009	80270884	002	RONDELLE GROWER	SPRING LOCK WASHER	FEDERING	RONDELLA GROWER	
010	A4061802	001	BOUCHON 3/8 CYL CHC+JOINT	PLUG + SEAL	STOPFEN + DICHRING	TAPPO	
011	A4061803	002	BOUCHON 1/2 CYL CHC+JOINT	PLUG + SEAL	STOPFEN + DICHRING	TAPPO	
012	A4071207	002	CLAPET	VALVE, FLAP	RUCKSCHLAGVENTIL	VALVOLA	
013	A4074017	002	COUPLEUR MALE	CONNECTOR MALE	KUPPLUNGSTECKER	INNESTO M16X150	
014	82300026	002	CAPUCHON COUPLEUR MALE	CAP MALE CONNECTOR	KAPPE KUPPLUNGSSTECKER	TAPPO	
015	A4080401	007	UNION MALE	MALE STUD CONNECTOR	GERADER EINSCHRAUBSTUTZEN	GIUZIONE DIRITTA ZBC	
016	A4080402	002	UNION MALE	MALE STUD CONNECTOR	GERADER EINSCHRAUBSTUTZEN	GIUZIONE DIRITTA ZBC	
017	A4050003	003	DISTRIBUTEUR CETOP3				
018	A4050005	001	DISTRIBUTEUR CETOP3				
019	A4101036	001	EMBASE	BASE	GRUNDPLATTE	BASE	
020	A4921115	001	FLEXIBLE HYDRAULIQUE	HYDRAULIC HOSE	HYDRAULIKSCHLAUCH	TUBO GOMMA	<->1600 mm
021	A4921115	001	FLEXIBLE HYDRAULIQUE	HYDRAULIC HOSE	HYDRAULIKSCHLAUCH	TUBO GOMMA	<->1600 mm
022	H0500740	001	SELECTEUR ELECTROHYDR. 4 FONC.	ELECTROHYDR. SELECTOR 4 FUNCT.	ELECTROHYDR. SELECTOR 4 FUNKT.	ELECTROIDRA. SELETTORE 4 FUNZ.	
023	H0600600	001	RENFORT	REINFORCEMENT	VERSTAERCKUNG	RINFORZO	
024	H0601520	001	CARTER	HOUSING	GEHAEUSE	SCATOLA	
025	H0600090	001	POIGNEE DE CDE ERGOKIT.4 INV.	JOYSTICK	STEUERKNUEPPEL	BARRA DI COMMANDO	
026	H0600100	001	FAISCEAU ELECTRIQUE 4,00M	ELECTRIC CABLE	KABELBAUM	FASCIO ELETTRICO	

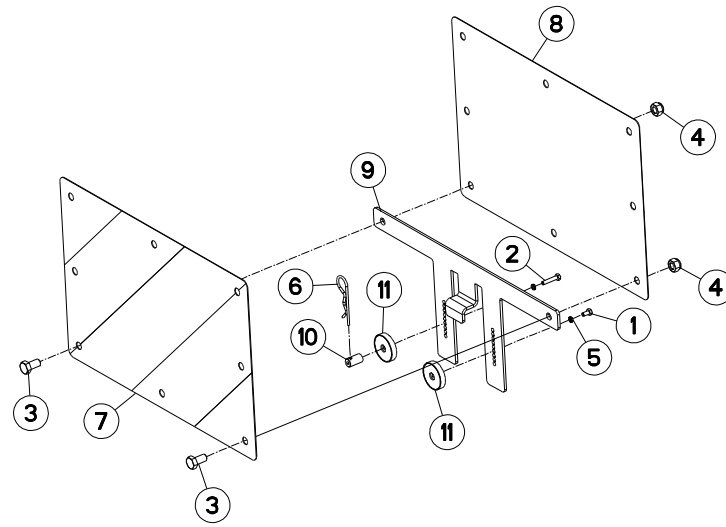



SIGNALISATION LATERALE

SIDE SIGNALLING

SEITLICHE WARNTAFELN

SEGNALAZIONE LATERALI

Rep	Nr	Qt	Designation	Description	Bezeichnung	Referenza	Remarque - Remark - Bemerkung - Osservazioni
001	80060510	001	VIS TETE HEXAGONALE FE/ZNXC3	HEXAGON HEAD SCREW FE/ZNXC3	SECHSKANTSCHRAUBE FE/ZNXC3	VITE TESTA ESAGONALE FE/ZNXC3	
002	80060527	001	VIS TETE HEXAGONALE FE/ZNXC3	HEXAGON HEAD SCREW FE/ZNXC3	SECHSKANTSCHRAUBE FE/ZNXC3	VITE TESTA ESAGONALE FE/ZNXC3	
003	80061072	002	VIS TETE HEXAGONALE FE/ZNXC3	HEXAGON HEAD SCREW FE/ZNXC3	SECHSKANTSCHRAUBE FE/ZNXC3	VITE TESTA ESAGONALE FE/ZNXC3	
004	80201030	002	ECROU HEX.AUTOFREINE FE/ZNXC3	SELF-LOCKING NUT FE/ZNXC3	SELBSTSICH.MUTTER FE/ZNXC3	DADO AUTOBLOCCANTE FE/ZNXC3	
005	80270584	002	RONDELLE GROWER	SPRING LOCK WASHER	FEDERRING	RONDELLA	
006	80570300	001	GOUPILLE BETA SIMPLE FE/ZNXC3	SPRING COTTER PIN FE/ZNXC3	FEDERSTECKER FE/ZNXC3	MOLLA FE/ZNXC3	
007	83240209	001	PANNEAU DE SIGNAL.RECT.ARD-AVG	WARNING PLATE	WARNTAFEL HI-RE + VO-LI	PANNELLO	
008	83240210	001	PANNEAU DE SIGNAL.RECT.ARG-AVD	WARNING PLATE	WARNTAFEL HI-LI + VO-RE	PANNELLO	
009	H0601790	001	SUPPORT	SUPPORT	TRAEGER	SUPPORTO	
010	H0601970	001	AXE	PIN	ACHSE	ASSE	
011	H0601980	002	AIMANT	MAGNET	MAGNET	AIMANT	

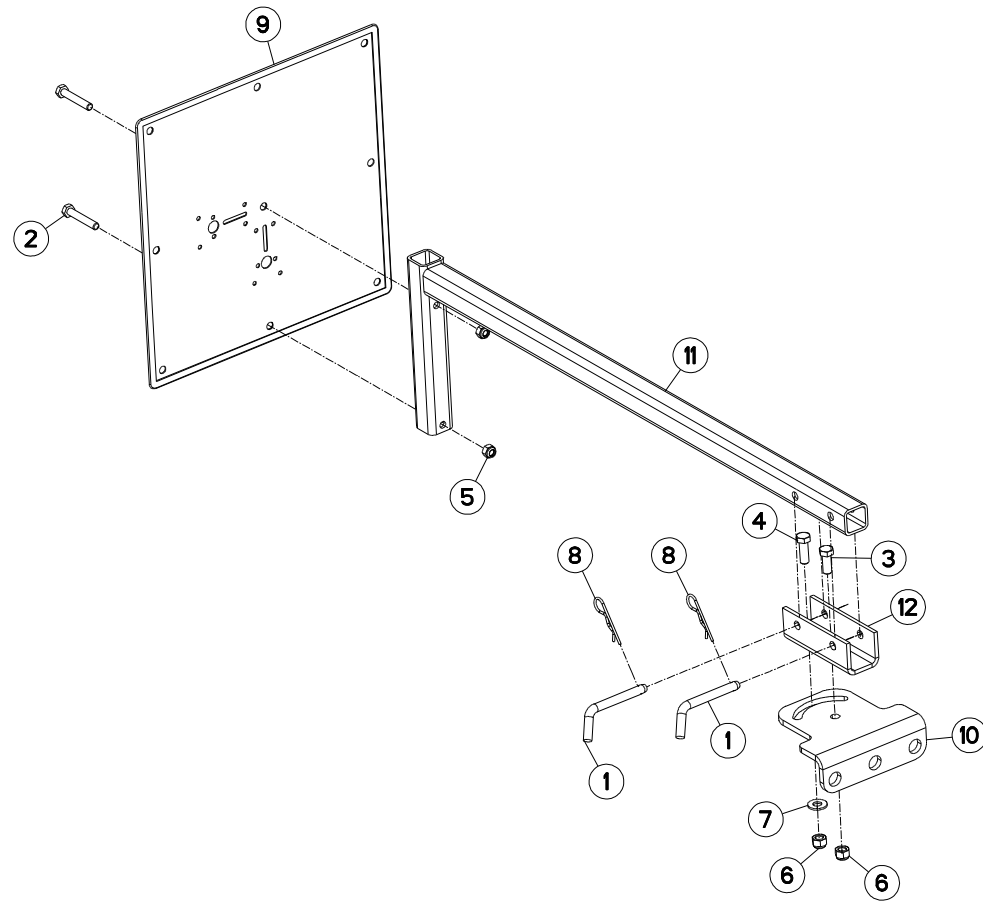



SIGNALISATION MM152T AV

SIGNALLING MM152T AV

BELEUCHTUNG U. WARNSCHILDER MM SEGNALAZIONE MM152T AV

Rep	Nr	Qt	Designation	Description	Bezeichnung	Referenza	Remarque - Remark - Bemerkung - Osservazioni
001	140297	002	BROCHE DE VERROUILLAGE	PIN	ACHSE	PERNO	
002	80061054	002	VIS TETE HEXAGONALE FE/ZNXC3	HEXAGON HEAD SCREW FE/ZNXC3	SECHSKANTSCHRAUBE FE/ZNXC3	VITE TESTA ESAGONALE FE/ZNXC3	
003	80061230	001	VIS TETE HEXAGONALE	HEXAGON HEAD SCREW	SECHSKANTSCHRAUBE	VITE A TESTA ESAGONALE	
004	80061236	001	VIS TETE HEXAGONALE FE/ZNXC3	HEXAGON HEAD SCREW FE/ZNXC3	SECHSKANTSCHRAUBE FE/ZNXC3	VITE TESTA ESAGONALE FE/ZNXC3	
005	80201031	002	ECROU HEX.AUTOFREINE FE/ZNXC3	SELF-LOCKING NUT FE/ZNXC3	SELBSTSICHERNDE MUTT.FE/ZNXC3	DADO AUTOBLOCCANTE FE/ZNXC3	
006	80201230	002	ECROU HEX.AUTOFREINE FE/ZNXC3	SELF-LOCKING NUT FE/ZNXC3	SELBSTSICH.MUTTER FE/ZNXC3	DADO AUTOBLOCCANTE FE/ZNXC3	
007	80251227	001	RONDELLE PLATE FE/ZNXC3	PLAIN WASHER FE/ZNXC3	SCHEIBE FE/ZNXC3	RONDELLA PIATTA FE/ZNXC3	
008	80570300	002	GOUPILLE BETA SIMPLE FE/ZNXC3	SPRING COTTER PIN FE/ZNXC3	FEDERSTECKER FE/ZNXC3	MOLLA FE/ZNXC3	
009	83240212	001	PANNEAU DE SIGNALISATION	WARNING PLATE	WARNTAFEL	PANNELLO B/R ANT.	
010	H0601660	001	EQUERRE	GUSSET, CORNER	WINKEL	SQUADRA	
011	H0601670	001	STRUCTURE	STRUCTURE	STRUKTUR	STRUTTURA	
012	H0601680	001	CHAPE	CLEVIS	GABEL	FORCELLA	

13
MULTI-MASTER 152 AV
 14

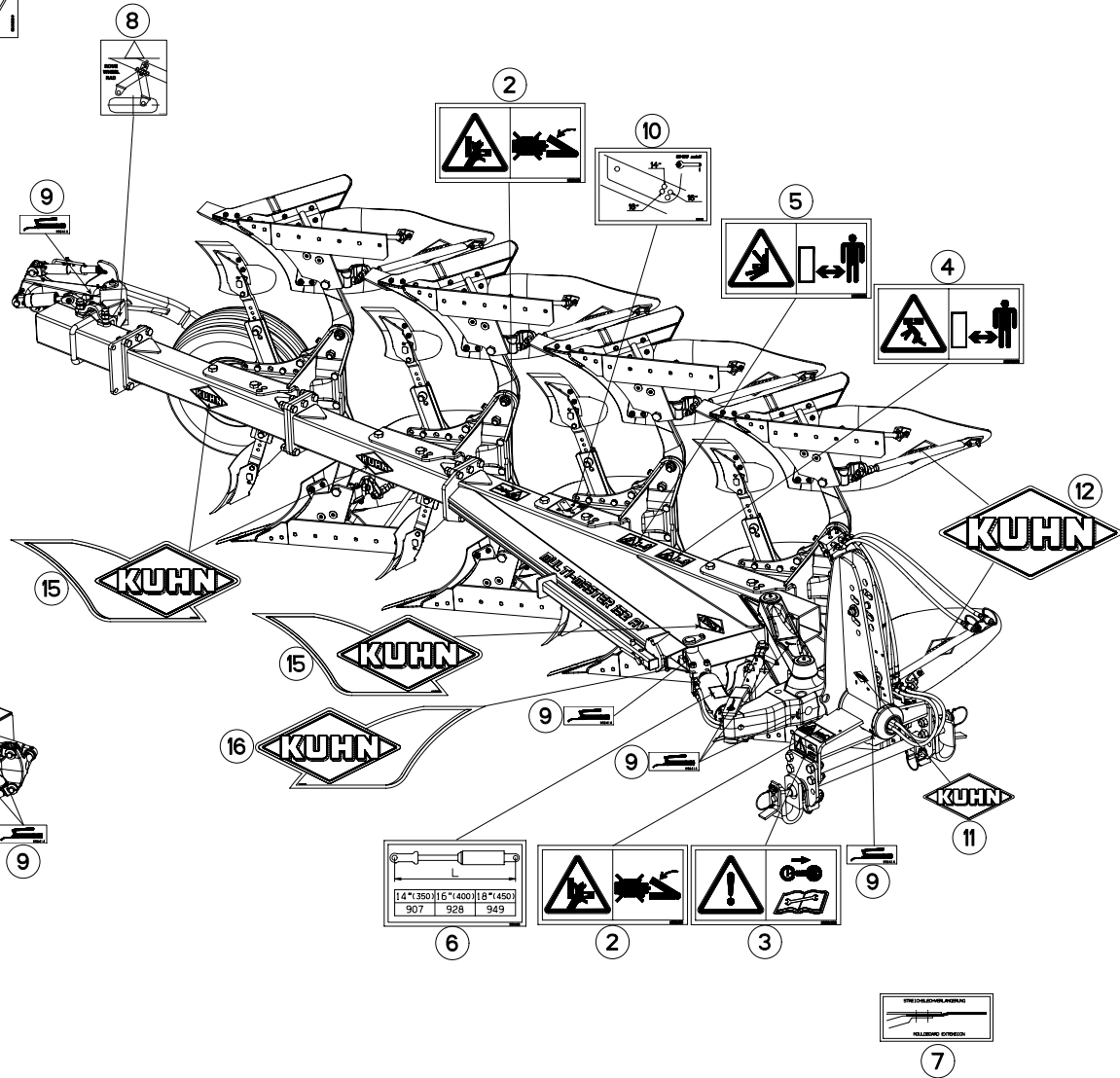
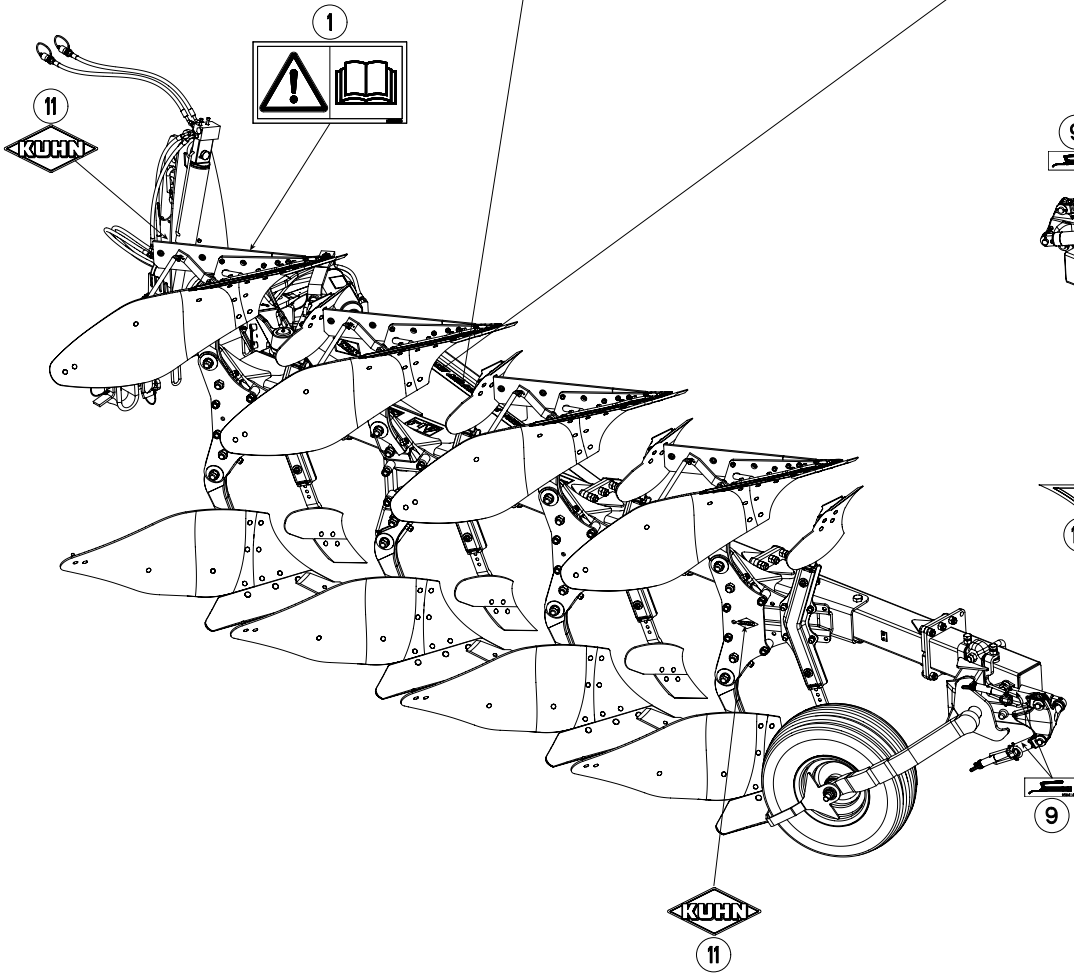



COLL.ETIQUETTES ADHESIVES MM15

SET OF STICKERS MM152T AV

SATZ AUFKLEBER MM152T AV

SERIE ADESIVI MM152T AV

Rep	Nr	Qt	Designation	Description	Bezeichnung	Referenza	Remarque - Remark - Bemerkung - Osservazioni
001	59900000	001	PICTOGR.H NOTICE D'INSTR	PICTORIAL H INSTRUCTIONS	PIKTOGR.H BETRIEBSANLEITUNG	ADESIVO	
002	59900300	002	PICTOGR.H ECRASEM.MAIN	PICTORIAL H CRUSH.DANGER HAND	PIKTOGR.H QUETSCHGEFAHR HAND	ADESIVO	
003	59900400	001	PICTOGR.H ARRETER MOTEUR	PICTORIAL H STOP ENGINE	PIKTOGR.H MOTOR ABSTELLEN	ADESIVO	
004	59900500	001	PICTOGR.H ECRASEM.CORPS	PICTORIAL H CRUSH. DANGER BODY	PIKTOGR.H QUETSCHGEF.KOERPER	ADESIVO	
005	59900600	001	PICTOGR.H ECRASEM.TORSE	PICTORIAL H CRUSH.DANG.TORSO	PIKTOGR.H QUETSCHGEF.BRUSTK	ADESIVO	
006	950165	001	AUTOCOL.L.COUBE MULTI 150 AV	ADHESIVE	AUFKLEBER	ADESIVO	
007	950333	001	AUTOCOL.POSITION RALLON.VERSOI	STICKER MDB EXTENSION	AUFKLEBER STREICHBLECHVERL.	ADESIVO	OPT
008	950408	001	AUTOCOL.POSITION ROUE REGUL.	STICKER	AUFKLEBER	ADESIVO	OPT
009	950414	001	AUTOCOL.POMPE A GRAISSE	STICKER OIL PUMP	AUFKLEBER SCHMIERUNG	ADESIVO	Q?
010	950495	001	AUTOCOL.L.COUP.MAS150 CHAL.	STICKER	AUFKLEBER	ADESIVO	
011	K9500010	001	LOGO KUHN 103 BLANC/TRANSP.	LOGO KUHN 103	LOGO KUHN 103	LOGO KUHN 103 BIANCO TRASP	Q? 2ET=4 3ET=5 4ET=6
012	K9500070	001	LOGO KUHN 207 BLANC/TRANSP.	LOGO KUHN 207	LOGO KUHN 207 WEISS/TRANSP.	LOGO KUHN 207 BIANCO TRASP.	Q? 2ET=4 3ET=6 4ET=8
013	K9505780	002	ETIQUETTE ADHESIVE	DECAL	AUFKLEBER	ADESIVO	
014	K9505830	002	ETIQUETTE ADHESIVE	DECAL	AUFKLEBER	ADESIVO	
015	K9530070	001	ETIQ.ADH.	DECAL	AUFKLEBER	ADESIVO	Q? 2ET=1 3ET=2 4ET=3
016	K9530080	001	ETIQ.ADH.	DECAL	AUFKLEBER	ADESIVO	



INDEX NUMERIQUE - NUMERICAL INDEX TEILENUMMERN-INDEX - INDICE NUMERICO

Nr	Page	Rep.	Nr	Page	Rep.	Nr	Page	Rep.	Nr	Page	Rep.	Nr	Page	Rep.	Nr	Page	Rep.	Nr	Page	Rep.	Nr	Page	Rep.
A4050003	027	017	H0500500	023	017	148132	019	004	583368	013	002	80200830	003	012	80450645	009	022	900210	003	022			
A4050005	027	018	H0500510	021	013	157146	005	002	59900000	033	001	80200830	025	005	80450645	019	025	900760	009	026			
A4061802	027	010	H0500510	023	018	191042	011	014	59900300	033	002	80200830	027	006	80450762	003	019	900788	019	014			
A4061803	027	011	H0500520	021	014	211604	015	003	59900400	033	003	80201030	027	007	80450928	017	010	920136	009	012			
A4071207	027	012	H0500520	023	019	211664	011	001	59900500	033	004	80201030	029	004	80500236	003	015	929157	009	027			
A4074017	003	027	H0500530	021	015	211829	005	003	59900600	033	005	80201031	031	005	80500345	019	026	950165	033	006			
A4074017	025	008	H0500530	023	020	212237	009	002	645280	015	008	80201230	005	015	80541280	005	018	950333	033	007			
A4074017	027	013	H0500580	021	016	212239	005	004	645281	019	012	80201230	009	020	80570300	029	006	950408	033	008			
A4080400	009	028	H0500590	021	017	227113	009	003	645297	009	007	80201230	031	006	80570300	031	008	950414	033	009			
A4080401	003	028	H0500740	027	022	227678	021	001	645314	019	013	80201601	017	007	80583000	005	019	950495	033	010			
A4080401	009	029	H0500910	021	018	227678	023	001	720029	009	008	80201630	015	011	80583500	009	023	951115	005	024			
A4080401	025	010	H0500920	023	021	261166	017	001	720030	005	023	80201647	009	021	81303062	023	008	951118	005	011			
A4080401	027	015	H0501070	019	029	421173	011	002	720031	009	009	80201669	015	012	81303072	021	007	951131	003	024			
A4080402	027	016	H0501110	023	022	421183	015	004	750047	009	010	80201670	011	012	81303072	023	009	951168	019	015			
A4080750	009	030	H0501120	023	023	421191	005	005	750091	003	004	80201670	017	008	81304079	021	008	951200	003	025			
A4082700	025	011	H0501800	019	030	421212	005	006	80060510	029	001	80202030	019	020	81304079	023	010	951204	023	004			
A4101036	027	019	H0600090	027	025	421213	005	007	80060527	029	002	80202047	013	005	81304079	023	011	951460	019	016			
A4921039	009	031	H0600100	027	026	421221	019	005	80060820	025	003	80202069	013	006	81309001	005	008	951521	005	012			
A4921039	009	032	H0600600	027	023	421223	011	003	80060826	027	001	80202070	015	013	82200600	021	009	951522	009	013			
A4921070	009	033	H0600650	003	033	421223	013	001	80060834	003	008	80202070	019	021	82200616	009	024	951523	009	014			
A4921070	009	034	H0601070	025	014	421223	019	006	80060834	025	004	80202420	015	014	82200800	023	012	951637	025	001			
A4921115	003	029	H0601480	003	034	421281	021	002	80060834	027	002	80202420	019	022	82200804	019	027	951668	011	010			
A4921115	003	030	H0601510	025	015	422069	017	002	80061054	031	002	80202421	011	013	82201002	005	020	951668	013	003			
A4921115	025	012	H0601520	027	024	445424	015	005	80061072	027	003	80202421	013	007	82201016	003	016	951730	005	025			
A4921115	025	013	H0601660	031	010	445592	011	004	80061072	029	003	80202440	019	023	82201016	005	021	951751	009	015			
A4921115	027	020	H0601670	031	011	445676	009	004	80061211	005	013	80202447	003	013	82201016	009	025	951776	003	006			
A4921115	027	021	H0601680	031	012	490102	005	009	80061230	031	003	80202447	015	015	82201016	015	018	951776	009	016			
A7250558	011	009	H0601790	029	009	500343	009	005	80061236	031	004	80203018	021	005	82201016	019	028	951832	003	023			
H0100800	005	026	H0601970	029	010	541001	007	001	80061248	009	017	80203018	023	006	82201016	023	013	952251	025	002			
H0101040	007	006	H0601980	029	011	580220	007	002	80061637	009	018	80250917	003	018	82300026	003	020	970108	003	007			
H0101450	003	031	K9500010	033	011	580296	007	003	80061641	011	011	80250917	025	006	82300026	025	009						
H0101500	003	032	K9500070	033	012	582144	011	005	80061647	017	004	80250917	027	008	82300026	027	014						
H0102170	003	026	K9505780	033	013	582146	011	006	80061681	015	009	80251227	031	007	83012225	019	017						
H0202220	011	015	K9505830	033	014	582196	015	006	80062049	019	018	80252432	019	024	83040197	003	017						
H0301390	005	027	K9530070	033	015	582197	015	007	80062059	019	019	80252755	007	004	83040197	005	022						
H0301460	005	028	K9530080	033	016	582216	017	003	80062068	013	004	80270584	029	005	83070064	003	021						
H0301470	005	029	130126	003	001	582311	019	007	80062076	015	010	80270884	025	007	83070064	007	005						
H0400200	011	016	130147	015	001	582518	011	007	80062461	003	009	80270884	027	009	83240209	029	007						
H0400200	013	008	130246	015	002	582603	019	008	80080530	027	004	80271686	017	009	83240210	029	008						
H0500440	023	014	130277	019	001	582606	019	009	80080570	027	005	80272085	015	016	83240212	031	009						
H0500480	021	010	130279	019	002	582692	009	006	80080890	003	010	80272484	005	016	900135	023	002						
H0500480	023	005	130283	019	003	582693	005	010	80080890	009	019	80283680	015	017	900142	003	005						
H0500480	023	015	131251	005	001	582715	019	010	80081240	005	014	80293020	021	006	900142	009	011						
H0500490	021	011	139046	009	001	582754	003	003	80091640	017	005	80293020	023	007	900155	021	003						
H0500490	023	016	139108	003	002	582897	019	011	80151635	017	006	80450610	003	014	900156	021	004						
H0500500	021	012	140297	031	001	583356	011	008	80190616	003	011	80450645	005	017	900168	023	003						

EXTRAIT DES CONDITIONS DE GARANTIE ET CONDITIONS SPECIFIQUES PIECES DE RECHANGE

Nous garantissons notre matériel durant une année à partir du jour de livraison, c'est-à-dire que nous nous engageons à rembourser les pièces qui auront été reconnues défectueuses en nos usines, par notre service technique.

Bien entendu, la garantie ne s'applique pas en cas d'usure normale, ni en cas de détériorations résultant de négligences ou de défauts de surveillance, d'un mauvais usage, d'un manque d'entretien ou d'un accident. La garantie ne s'applique pas non plus si la machine a été prêtée ou utilisée pour un usage non conforme à sa destination prévue par la société.

La garantie ne s'applique pas aux pièces d'usure.

Les pièces de rechange sont soumises aux mêmes conditions de garantie que le matériel sous réserve qu'elles aient été montées selon les règles de l'art et utilisées conformément à nos recommandations.

EXTRACT FROM OUR CONDITIONS OF LIMITED WARRANTY AND SPARE PARTS WARRANTY POLICY

Our equipment is warranted for a period of one year from the date of delivery. We guarantee the reimbursement of all parts proven to be faulty by our technical division in material or manufacturing.

The warranty is not applicable in the following cases : normal wear, accident or negligence in operation, repairs using parts other than genuine KUHN parts, products altered or modified without the expressed permission of the company or if the machine is not used and serviced in accordance with the recommendations of the operator's manual. Wearing items are not covered under these conditions of limited warranty.

Spare parts are subject to the same warranty conditions than the equipment providing they have been installed with proficiency and are used in accordance with our recommendations.

AUSZUG AUS UNSEREN GARANTIEBEDINGUNGEN UND SONDERBEDINGUNGEN FÜR ERSATZTEILE

Wir garantieren unsere Ware für ein Jahr ab dem Tag der Lieferung und verpflichten uns, die Teile zu ersetzen, die im Werk als fehlerhaft anerkannt wurden.

Die Garantie ist ausgeschlossen für Teile, die einem normalen Verschleiß unterliegen, sowie im Fall von nachlässiger Behandlung oder mangelhafter Wartung oder eines Unfalls. Die Garantie erlischt auch, wenn die Maschine ausgeliehen oder unter Umständen eingesetzt wurde, die dem ursprünglichen Verwendungszweck und den Hinweisen in der Betriebsanleitung nicht entsprechen.

Verschleißteile sind von der Garantie ausgeschlossen

Ersatzteile unterliegen den gleichen Garantiebedingungen wie komplette Maschinen, vorausgesetzt, dass sie sachgerecht eingebaut und entsprechend unseren Empfehlungen verwendet wurden.

ESTRATTO DELLE CONDIZIONI DI GARANZIA E CONDIZIONI SPECIFICHE GARANZIA RICAMBI

Le nostre macchine sono garantite per un anno a partire dal giorno della consegna: ci impegnamo a rimborsare i componenti che saranno riconosciuti difettosi dai nostri servizi tecnici presso le nostre officine.

La garanzia non è applicabile nei seguenti casi: usura normale, incidente o negligenza nell'impiego, riparazioni utilizzando ricambi non originali KUHN, prodotti alterati o modificati senza il permesso dell'azienda. La garanzia non viene riconosciuta se la macchina è stata prestata o non è utilizzata o mantenuta in conformità alle raccomandazioni previste dalla società. La garanzia non copre i componenti soggetti ad usura.

I pezzi di ricambio sono soggetti agli stessi termini di garanzia della macchina, purchè siano stati installati con competenza e utilizzati conformemente alle nostre raccomandazioni.



**Pour votre sécurité et le bon fonctionnement de votre machine,
utilisez uniquement des pièces d'origine KUHN**

**For your safety and to get the best from your machine,
use only genuine KUHN parts**

**Zu ihrer Sicherheit und zur einwandfreien Funktion Ihrer
Maschine sollten Sie nur Original-KUHN-Ersatzteile verwenden**

**Per la vostra sicurezza, e per il buon funzionamento della vostra macchina,
usate esclusivamente i ricambi originali KUHN**

KUHN PARTS Parc de la Faisanderie F - 67700 MONSWILLER (FRANCE)

Tél.: + 33 (0) 3 88 01 81 00 - Fax : + 33 (0) 3 88 01 81 03

www.kuhn.com

Imprimé en France par KUHN
Printed in France by KUHN