

Pièces de rechange
Spare parts list
Ersatzteilliste
Catalogo Pezzi di Ricambio



CHARRUE PORTEE
MOUNTED REVERSIBLE PLOUGH
VOLLDREHPFLUG
ARATRO PORTATO



J7465 > K9999

MULTI-MASTER 110T J





SIGNES CODIFIÉS - STANDARD SYMBOLS - SYMBOLE - SIMBOLI CODIFICATI

OPT	Equipement optionnel
STD	Equipement livré de série
ESP	Equipement livré suivant pays
:	Pour ...
>	De ... à ...
RPL	Remplace ...
∅	Diamètre
> <	Epaisseur
<->	Longueur
<m>	Vendu au mètre
Q?	Quantité selon besoin
*	Voir note
[n]	Composant d'un assemblage
+ [n]	Assemblage comprenant les pièces [n]

OPT	Optional equipment
STD	Equipment supplied as standard
ESP	Equipment supplied for specific countries
:	For ...
>	From ... to ...
RPL	Replaces ...
∅	Diameter
> <	Thickness
<->	Length
<m>	Sold by the metre
Q?	Quantity as required
*	See note
[n]	Items making up assembly
+ [n]	Assembly made up by items [n]

OPT	Sonderausrüstung
STD	Serienausrüstung
ESP	Länderabhängige Ausrüstung
:	Für ...
>	Von ... bis ...
RPL	Ersetzt ...
∅	Durchmesser
> <	Stärke
<->	Länge
<m>	Meterware
Q?	Stückzahl nach Bedarf
*	Siehe Nota
[n]	Teil einer Baugruppe
+ [n]	Baugruppe bestehend aus den mit [n] bezeichneten Teilen

OPT	Attrezzatura opzionale
STD	Attrezzatura fornita di serie
ESP	Attrezzatura fornita secondo il paese
:	Per ...
>	Da ... A ...
RPL	Sostituisce ...
∅	Diametro
> <	Spessore
<->	Lunghezza
<m>	venduto a metro
Q?	Quantità richiesta
*	Vedi nota
[n]	Componente di un assieme
+ [n]	Assieme comprendente i componenti [n]

POUR COMMANDER DES PIÈCES DE RECHANGE, VEUILLEZ INDIQUER:

- Le numéro de fabrication de la machine
- Le numéro de la pièce
- La quantité désirée

WHEN ORDERING SERVICE-PARTS, WILL YOU PLEASE MENTION:

- The machine type and serial number
- The part number
- The quantity of parts

BEI DER BESTELLUNG VON ERSATZTEILEN IMMER ANGEBEN:

- Die Seriennummer der Maschine
- Die Nummer des Teiles
- Die gewünschte Stückzahl

NELL'ORDINARE I RICAMBI, SI PREGA DI INDICARE:

- Il tipo ed il numero di serie della macchina
- Il codice del componente
- La quantità desiderata

- Toutes les pièces détachées et sous-ensembles sont à commander au magasin pièces de rechange.
- **Les équipements optionnels (OPT)** ainsi que les **notices d'instructions** sont à commander auprès des **services commerciaux**.

- Service parts and service part assemblies are to be ordered through the spare parts department.
- **Optional equipment (OPT)** and **assembly operator's manuals** should be ordered through the **wholesaler sales department**.

- Bestellungen für Ersatzteile und Baugruppen sind an die Ersatzteilabteilung zu richten.
- **Sonderausrüstungen (OPT)** sowie **Montage- und Betriebsanleitungen**, bestellen Sie bitte bei der **Verkaufsabteilung für Maschinen**.

- I ricambi e i sotto-assiemi devono essere ordinati al Magazzino Ricambi.
- **Le attrezzature opzionali (OPT)** ed i **manuali dell'operatore** devono essere ordinati al **Servizio Commerciale**.

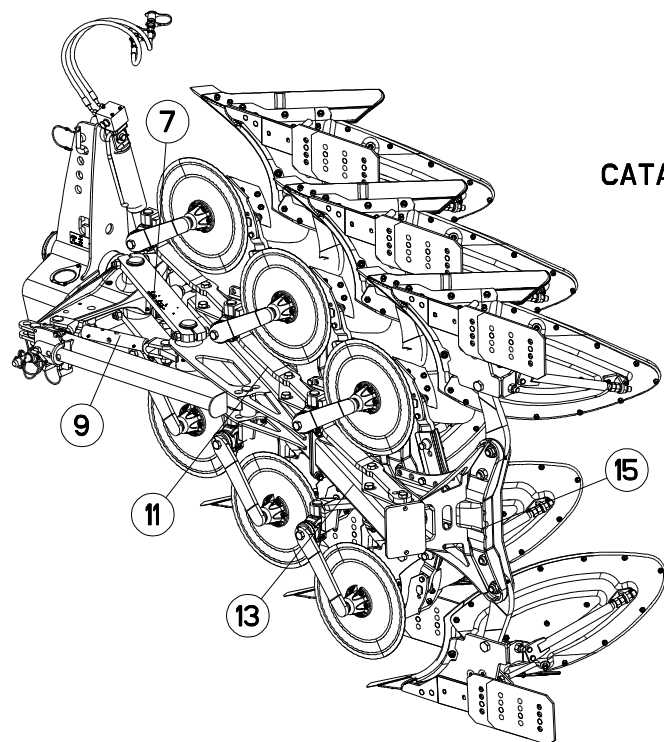
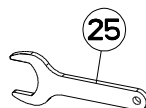
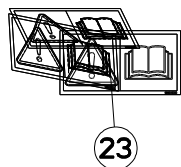

CATALOG./LIST N° HR009ATL

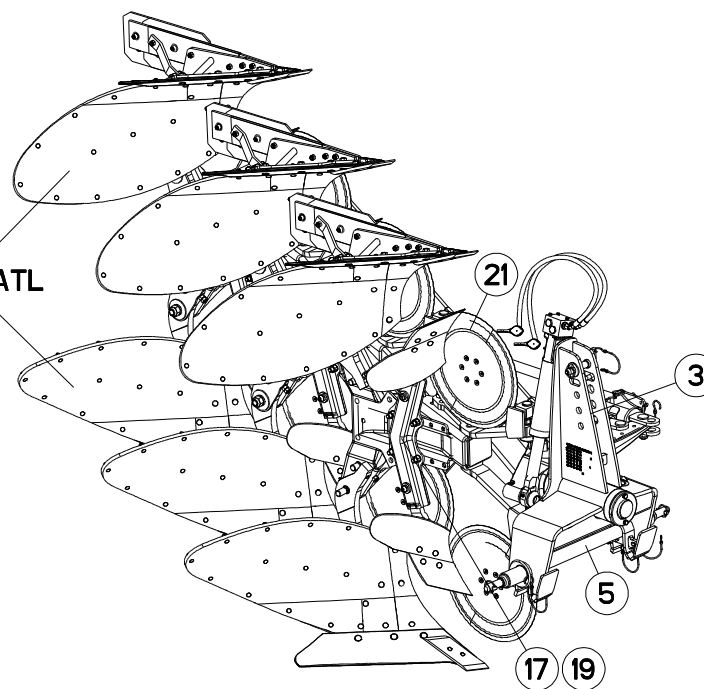



TABLE DES MATIERES - TABLE OF CONTENTS - INHALTSVERZEICHNIS - INDICE

H15R0010 C

Catalogue P.D.R. - Spare parts list - Ersatzteilliste - Pezzi di Ricambio :

HR044CTL A

Page	Opt	Groupe de pièces	Parts group index	Teilegruppe	Gruppo di parti
003		AVANT-TRAIN D	HEADSTOCK D	PFLUGKOPF D	TESTA DI ROTAZIONE D
005		TRAVERSE STD2	CROSS SHAFT CAT 2	TRAGACHSE KAT 2	BARRA TERZO PUNTO CAT.2
007		PARTIE MÉDIANE D	MAIN LINK D	MITTELTEIL D	TIRANTE PRINCIPALE D
009		DEPORT / LARGEUR DE COUPE MECA	OFF SETTING / MECHANICAL CUTTI	VERSATZSTUECK / MECHANISCHE KO	SFALSAMENTO / LARGHEZZA DI TAG
011		BATI MM110/2 2ET J	FRAME MM110/2 2ET J	RAHMEN MM110/2 2ET J	TELAIO MM110/2 2ET J
013		EXTENSION MM110/2 T J	EXTENSION MM110/2 T J	ERWEITERUNG MM110/2 T J	PROLUNGA MM110/2 T J
015		AGE SECURITE T	PLOUGH LEG SAFETY T	GRINDEL STEINSICHERUN T	BURE DI SICUREZZA T
017		BOITIER TIGES RASETTE	SKIMMER LEG/SUPPORT	HALTERUNG/VORSCHALESTIEL	GAMBO DEL PREVOMERE
019		BOITIER TIGES RASETTE	SKIMMER SUPPORT	VORSCHAELESTIEL/HALTERUNG	SUPPORTO AVANVOMERE
021		COUTRE CIRCULAIRE	DISC COULTER	SCHEIBENSECH	ASSOLCATORE A DISCO
023		ETIQUETTES ADHESIVES MM112 T	STICKERS MM112 T	AUFKLEBER MM112 T	ADESIVI MM112 T
025		OUTILLAGE	TOOLS	WERKZEUG	ATTREZZI

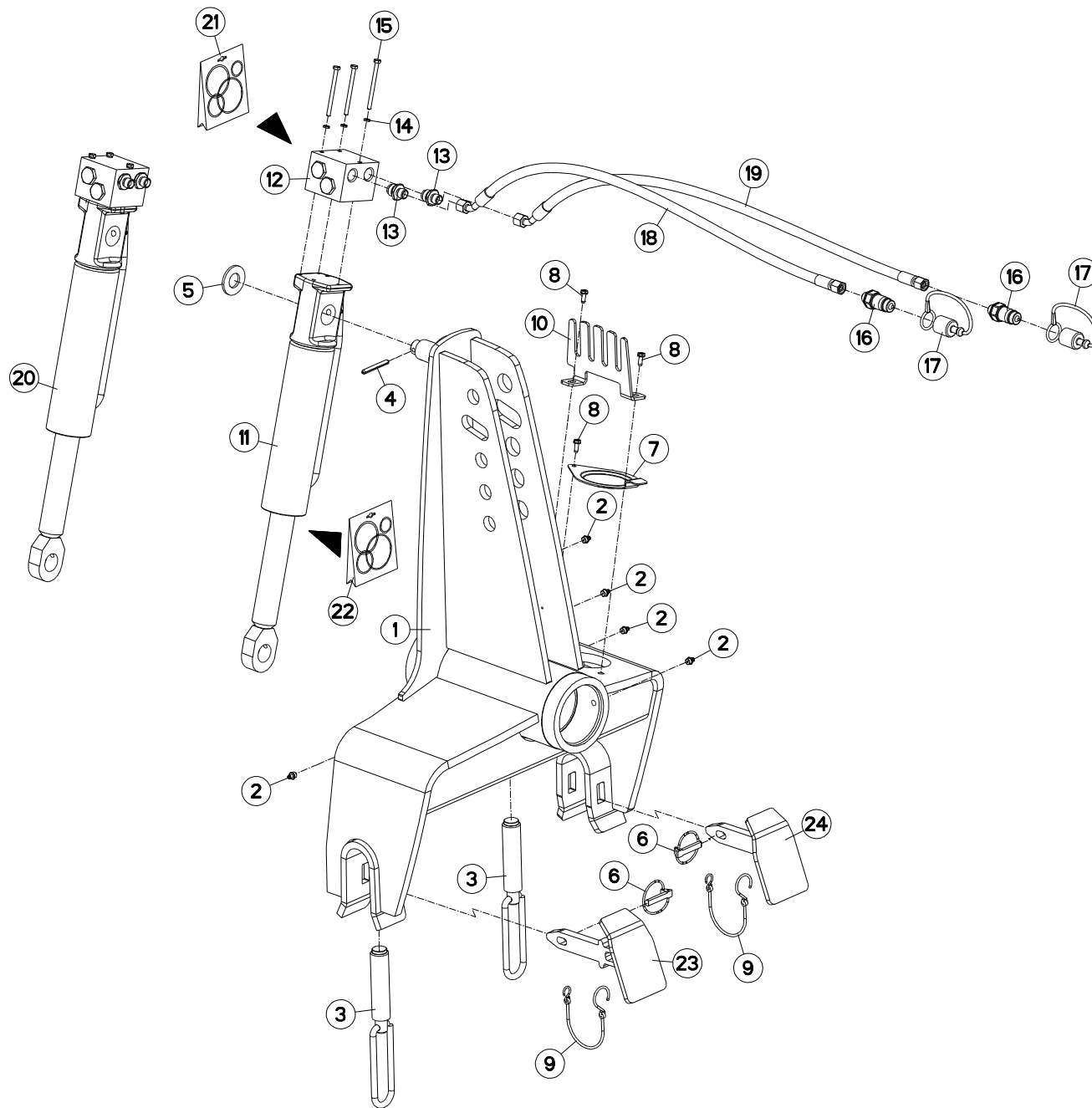



MULTI-MASTER 110T J

J7465 >K9999

H01R0011 F

AVANT-TRAIN D

HEADSTOCK D

PFLUGKOPF D

TESTA DI ROTAZIONE D

Rep	Nr	Qt	Designation	Description	Bezeichnung	Referenza	Remarque - Remark - Bemerkung - Osservazioni
001	H0101490	001	POTENCE	BOOM	TRAGARM	ATTACCO ATTREZZO	
002	82201016	005	GRAISSEUR AUTOTARAUDANT	SELF TAPPING GREASE NIPPLE	GEWINDESCHNEID-SCHMIERNIPPEL	INGRASSATORE	
003	H0100080	002	BUTEE D'APLOMB	STOP	ANSCHLAG	LIMITATORE	
004	80450762	001	GOUPILLE ELASTIQUE FLZNNC	ROLL PIN FLZNNC	SPANNHUELSE FLZNNC	SPINA ELASTICA FLZNNC	
005	80252432	001	RONDELLE PLATE FE/ZNXC3	PLAIN WASHER FE/ZNXC3	SCHEIBE FE/ZNXC3	RONDELLA PIATTA FE/ZNXC3	
006	900210	002	GOUPILLE DE SECURITE D 11,50	LYNCH PIN D11,50	KLAPPSTECKER D 11,50	SPINA DI SICUREZZA	
007	H0600650	001	COUVERCLE	LID	DECKEL	COPERCHIO	
008	80190616	003	VIS AUTOTARAU.FE/ZNXC3 TAPTITE	SELF-CUTTING SCREW FE/ZNXC3	GEWINDE-SCHNEIDSCHRAU.FE/ZNXC3	BULLONE FE/ZNXC3	
009	83070064	002	LIEN PVC	PVC CORD	SICHERUNGSBAND	CAVO	
010	H0601480	001	RATELIER	RACK	GESTELL	CREMAGLIERA	
011	H0300530	001	VERIN	CYLINDER, HYDRAULIC	HYDRAULIKZYLINDER	CILINDRO	[1]
012	900473	001	BLOC DE DISTRIBUTION	HYDRAULIC BLOCK	UMSCHALTBLOCK	BLOCCO DISTRIBUZIONE	[1]
013	900474	002	RACCORD FILTRE	FILTER MOUNTING	GEWINDESTUTZEN	RACCORDO FILTRO	
014	80270684	003	RONDELLE GROWER	SPRING LOCK WASHER	FEDERRING	RONDELLA	[1]
015	80060681	003	VIS TETE HEXAGONALE FE/ZNXC3	HEXAGON HEAD SCREW FE/ZNXC3	SECHSKANTSCHRAUBE FE/ZNXC3	VITE TESTA ESAGONALE FE/ZNXC3	[1]
016	A4074017	002	COUPLEUR MALE	CONNECTOR MALE	KUPPLUNGSTECKER	INNESTO M16X150	
017	82300026	002	CAPUCHON COUPLEUR MALE	CAP MALE CONNECTOR	KAPPE KUPPLUNGSSTECKER	TAPPO	
018	A4921115	001	FLEXIBLE HYDRAULIQUE	HYDRAULIC HOSE	HYDRAULIKSCHLAUCH	TUBO GOMMA	<->1600 mm
019	A4921115	001	FLEXIBLE HYDRAULIQUE	HYDRAULIC HOSE	HYDRAULIKSCHLAUCH	TUBO GOMMA	<->1600 mm
020	H0300540	001	VERIN	CYLINDER, HYDRAULIC	HYDRAULIKZYLINDER	CILINDRO	+ [1]
021	900331	001	POCHETTE DE JOINTS (900467/8)	SEALS PACKET 900467/8)	DICHTUNGSSATZ (900467/8)	SERIE GUARNIZIONI	: H0300530
022	900483	001	POCHETTE DE JOINTS (900473)	SEALS PACKET	DICHTUNGSSATZ FUER 900473	SERIE GUARNIZIONI	: 900473
023	H0100380	001	BROCHE D'ATTELAGE	PIN, HITCH	ACHSE	PERNO	
024	H0100390	001	BROCHE D'ATTELAGE	PIN, HITCH	ACHSE	PERNO	

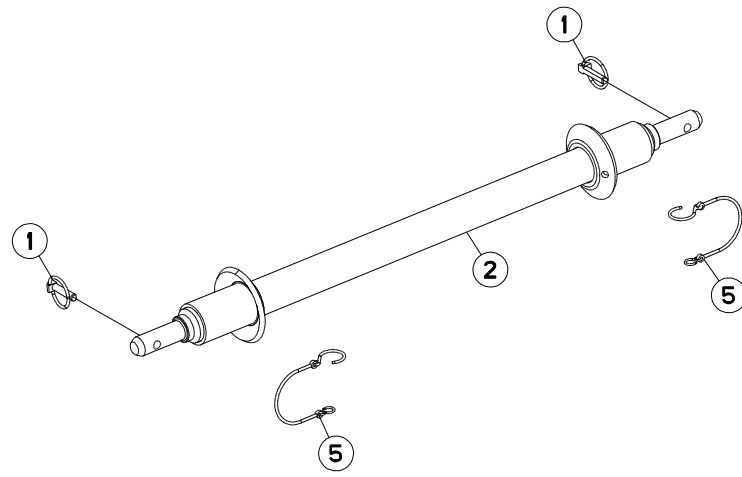
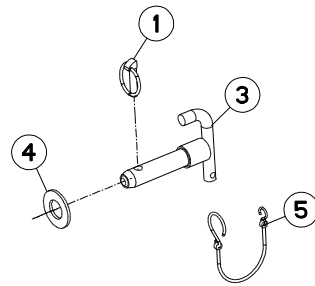



MULTI-MASTER 110T J

J7465 >K9999

H01R0012 B

TRAVERSE STD2

CROSS SHAFT CAT 2

TRAGACHSE KAT 2

BARRA TERZO PUNTO CAT.2

Rep	Nr	Qt	Designation	Description	Bezeichnung	Referenza	Remarque - Remark - Bemerkung - Osservazioni
001	541001	003	GOUPILLE RAPIDE	LYNCH PIN D10 CAT2	KLAPPSTECKER D10 KAT2	CAPPIGLIA	
002	545069	001	TRAVERSE	TUBE, CROSS	QUERTRAEGER	TRAVERSA	
003	580296	001	AXE 3 POINT STANDARD 2 D25	TOP LINK PIN CAT2	OBERLENKERBOLZEN KAT 2	PERNO 3 PUNTI STANDARD 2	
004	80252755	001	RONDELLE PLATE FE/ZNXC3	PLAIN WASHER FE/ZNXC3	SCHEIBE FE/ZNXC3	RONDELLA PIATTA FE/ZNXC3	
005	83070064	003	LIEN PVC	PVC CORD	SICHERUNGSBAND	CAVO	

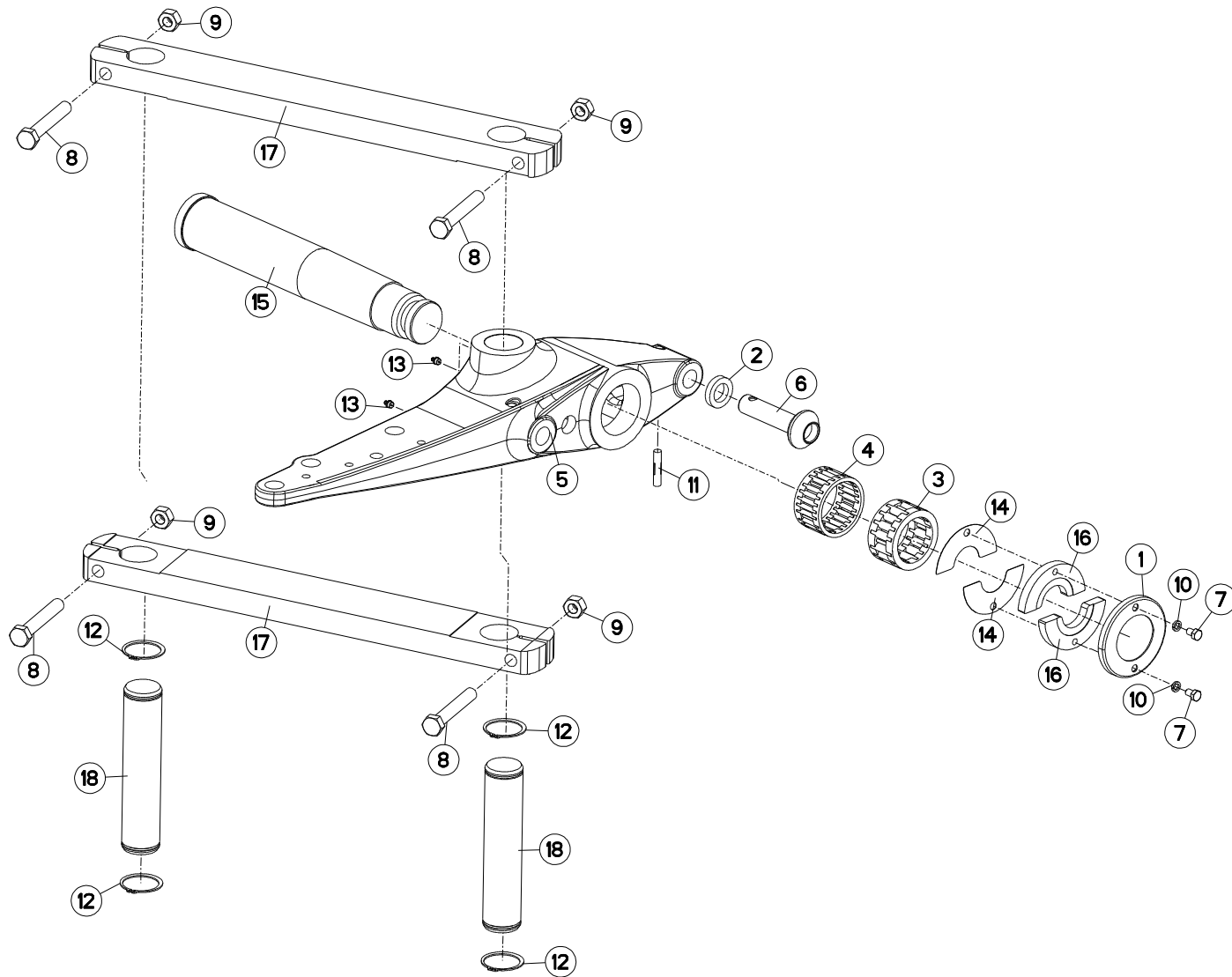



MULTI-MASTER 110T J J7465 >K9999

H03R0104 A

PARTIE MÉDIANE D

MAIN LINK D

MITTELTEIL D

TIRANTE PRINCIPALE D

Rep	Nr	Qt	Designation	Description	Bezeichnung	Referenza	Remarque - Remark - Bemerkung - Osservazioni
001	116042	001	COUPELLE	CUP	SCHALE	COPPIGLIA	
002	421249	001	RONDELLE TOURILLON	WASHER	SCHEIBE	RONDELLA	
003	490025	001	ROULEMT.RLX 75X100X55	BEARING, ROLLER	ROLLENLAGER	CUSCINETTO	
004	490063	001	ROULEMT.RLX 85X100X55	BEARING, ROLLER	ROLLENLAGER	CUSCINETTO	
005	645300	001	SUPPORT D'ENTRAINEMENT "D"	BRACKET	HALTERUNG	SUPPORTO	
006	720037	001	TOURILLON	TRUNNION	DREHZAPFEN	PERNO	
007	80061016	002	VIS TETE HEXAGONALE FE/ZNXC3	HEXAGON HEAD SCREW FE/ZNXC3	SECHSKANTSCHRAUBE FE/ZNXC3	VITE TESTA ESAGONALE FE/ZNXC3	
008	80062086	004	VIS TETE HEXAGONALE FE/ZNXC3	HEXAGON HEAD SCREW FE/ZNXC3	SECHSKANTSCHRAUBE FE/ZNXC3	VITE TESTA ESAGONALE FE/ZNXC3	
009	80202047	004	ECROU HEXAG. AUTOFREINE FLZNNC	SELF-LOCKING NUT FLZNNC	SELBSTSICHERNDE MUTTER FLZNNC	DADO AUTOBLOCCANTE FLZNNC	
010	80271084	002	RONDELLE GROWER	SPRING LOCK WASHER	FEDERRING	RONDELLA GROWER	
011	80541260	001	GOUPILLE CANNELEE	GROOVED PIN	KERBSTIFT	COPPIGLIA	
012	80586000	004	CIRCLIP EXTERIEUR	RETAINING RING	SICHERUNGSRING	ANELLO	
013	82201016	002	GRAISSEUR AUTOTARAUDANT	SELF TAPPING GREASE NIPPLE	GEWINDESCHNEID-SCHMIERNIPPEL	INGRASSATORE	
014	H0100720	002	CLINQUANT	FOIL	FLITTER	CARTA STAGNOLA	
015	H0102140	001	FUSEE	SPINDLE	DREHZAPFEN	FUSO	
016	H0102150	002	DEMI-BAGUE	BUSHING, HALF	HUELSENHAELFTR	FUSO	
017	H0301680	002	BIELLE	LINK, CONNECTING	LENKER	BIELLA	
017	H0300150	002	BIELLE	LINK, CONNECTING	LENKER	BIELLA	: MM112 J
018	H0301690	002	AXE	PIN	ACHSE	ASSE	
018	H0300200	002	AXE	PIN	ACHSE	ASSE	: MM112 J

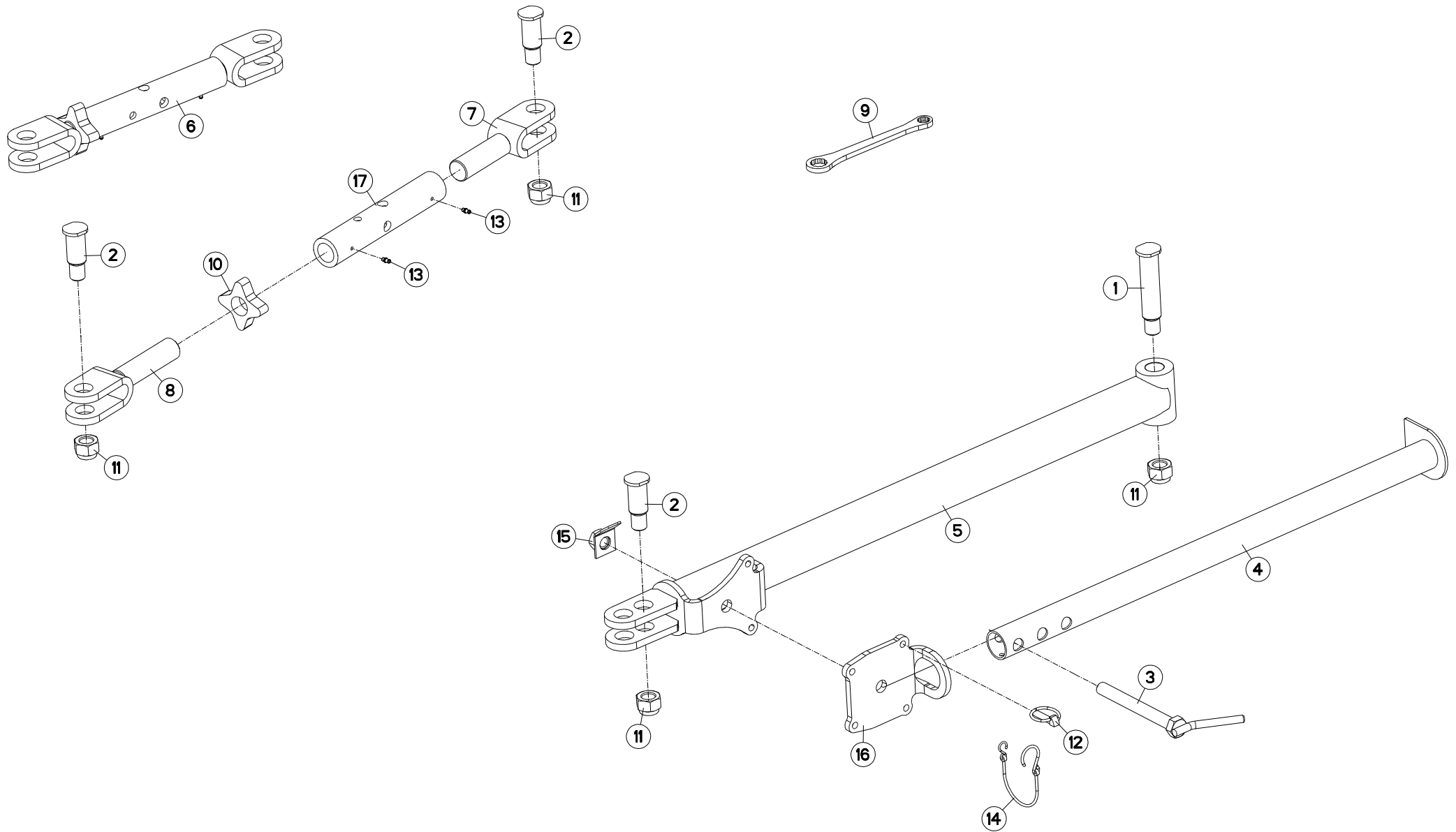



MULTI-MASTER 110T J

J7465 >K9999

H03R0003 B

DEPORT / LARGEUR DE COUPE MECA OFF SETTING / MECHANICAL CUTTI VERSATZSTUECK / MECHANISCHE KO SFALSAMENTO / LARGHEZZA DI TA

Rep	Nr	Qt	Designation	Description	Bezeichnung	Referenza	Remarque - Remark - Bemerkung - Osservazioni
001	720038	001	AXE	PIN	ACHSE	ASSE	
002	720039	003	AXE	PIN	ACHSE	ASSE	
003	H0600010	001	AXE DE BRIDAGE	AXLE	ACHSE	ASSE	
004	H0600000	001	BEQUILLE	STAND	STÄNDER	SUPPORTO	
005	H0300190	001	BIELLE	LINK, CONNECTING	LENKER	BIELLA	
006	H0300240	001	BIELLE DEPORT-DEVERS	PULL BAR	SCHUBSTANGE	BIELLA	
007	H0300170	002	CHAPE PAS A GAUCHE	YOKE	GABEL	FORCELLA	
008	H0300180	002	CHAPE PAS A DROITE	YOKE	GABEL	FORCELLA	
009	H0600040	001	CLE 18 / 24	SPANNER	SCHLUESSEL	CHIAVE	
010	750084	002	ECROU A FRAPPER	NUT	SCHRAUBE	DADO	
011	80202440	004	ECROU HEX.AUTOFREINE FE/ZNXC3	SELF-LOCKING NUT FE/ZNXC3	SELBSTSICHERNDE MUTT.FE/ZNXC3	DADO AUTOBLOCCANTE FE/ZNXC3	
012	541001	001	GOUPILLE RAPIDE	LYNCH PIN D10 CAT2	KLAPPSTECKER D10 KAT2	CAPPIGLIA	
013	82200616	004	GRAISSEUR AUTOTAR.FE/ZNXC3	TAPPING GREASE NIPPLE FE/ZNXC3	GEWINDESCH.SCHMIERNIP.FE/ZNXC3	INGRASSATORE FE/ZNXC3	
014	83070064	001	LIEN PVC	PVC CORD	SICHERUNGSBAND	CAVO	
015	H0300230	001	PATTE	PLATE	PLATTE	FLANGIA	
016	750079	001	PLAQUE	PLATE	PLATTE	PIASTRA	
017	H0300160	002	TUBE DE BIELLE	TUBE	ROHR	TUBO	

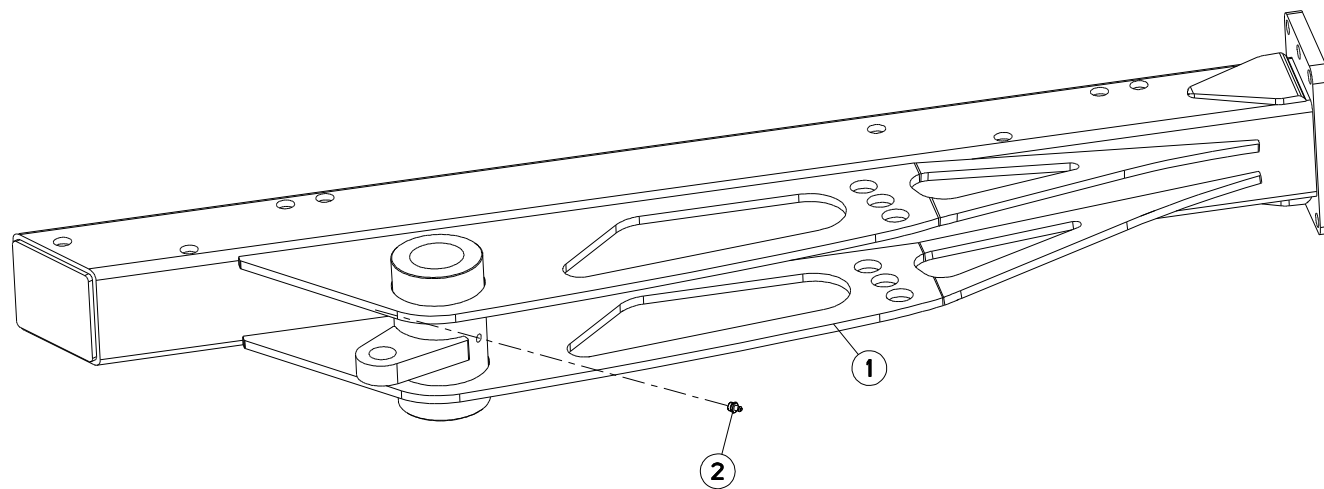



MULTI-MASTER 110T J

J7465 >K9999

H02R0001 A

BATI MM110/2 2ET J

FRAME MM110/2 2ET J

RAHMEN MM110/2 2ET J

TELAIO MM110/2 2ET J

Rep	Nr	Qt	Designation	Description	Bezeichnung	Referenza	Remarque - Remark - Bemerkung - Osservazioni
001	H0200270	001	BATI 2"™ JAPON	BEAM	RAHMEN	TELAIO	
002	82201016	001	GRAISSEUR AUTOTARAUDANT	SELF TAPPING GREASE NIPPLE	GEWINDESCHNEID-SCHMIERNIPPEL	INGRASSATORE	

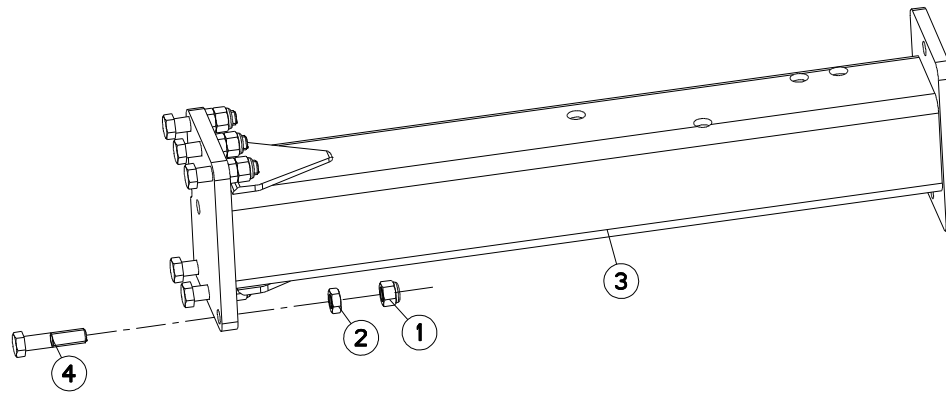



MM1 123T8090J J7465 >K9999

H02R0002 A

EXTENSION MM110/2 T J

EXTENSION MM110/2 T J

ERWEITERUNG MM110/2 T J

PROLUNGA MM110/2 T J

Rep	Nr	Qt	Designation	Description	Bezeichnung	Referenza	Remarque - Remark - Bemerkung - Osservazioni
001	80201647	006	ECROU HEX.AUTOFREINE FE/ZNXC3	SELF-LOCKING NUT FE/ZNXC3	SELBSTSICHERNDE MUTT.FE/ZNXC3	DADO AUTOBLOCCANTE FE/ZNXC3	
002	80201669	006	ECROU HEXAGONAL FE/ZNXC3	NUT FE/ZNXC3	SECHSKANTMUTTER FE/ZNXC3	DADO FE/ZNXC3	
003	H0200380	001	EXTENSION JAPON	EXTENSION	ERWEITERUNG		
004	80061637	006	VIS TETE HEXAGONALE FLZNNC	HEXAGON HEAD SCREW FLZNNC	SECHSKANTSCHRAUBE FLZNNC	VITE TESTA ESAGONALE FLZNNC	

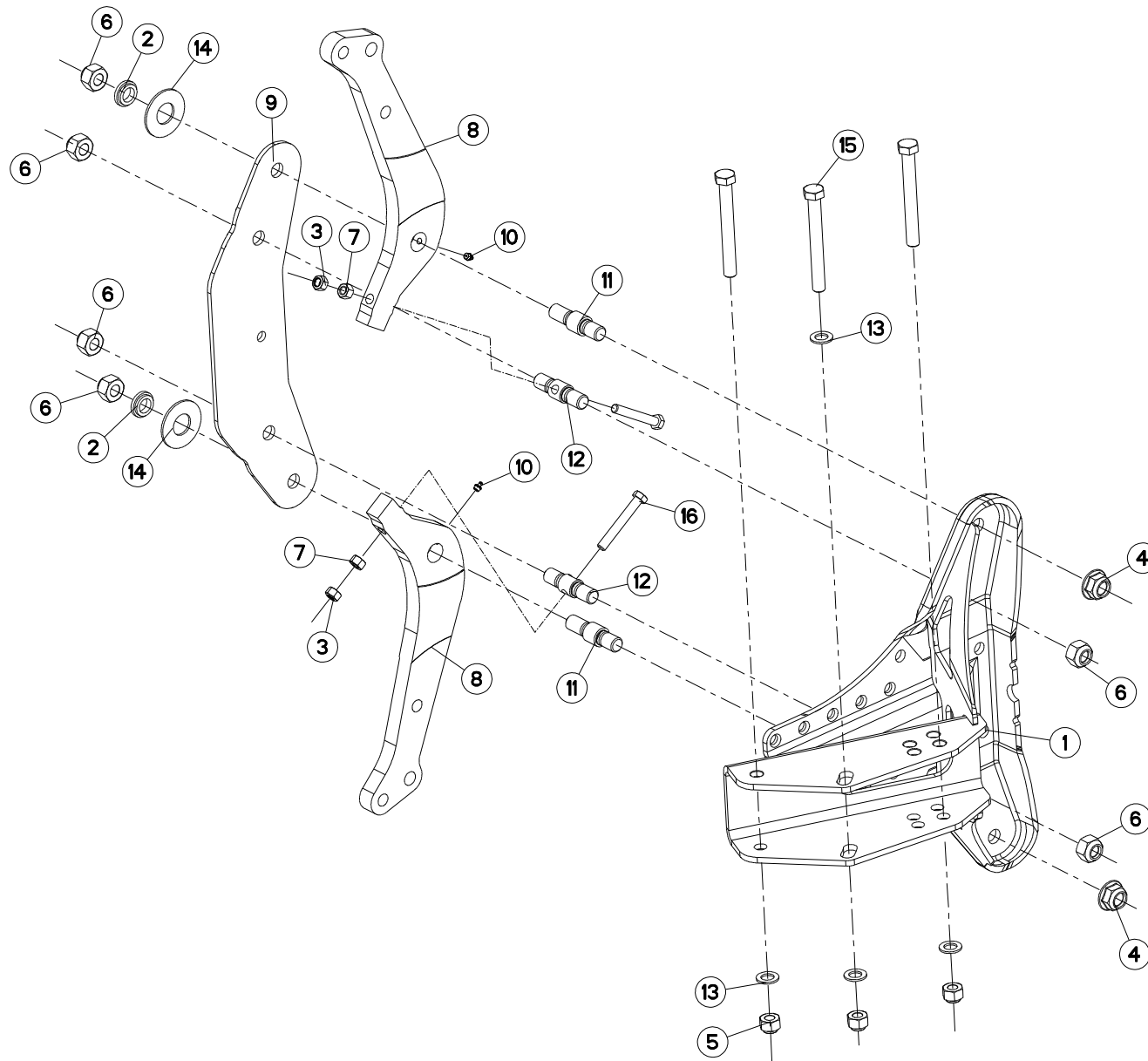



MULTI-MASTER 110T J

J7465 >K9999

H04R0004 B

AGE SECURITE T

PLOUGH LEG SAFETY T

GRINDEL STEINSICHERUN T

BURE DI SICUREZZA T

Rep	Nr	Qt	Designation	Description	Bezeichnung	Referenza	Remarque - Remark - Bemerkung - Osservazioni
001	H0400331	001	BOITIER SUPPORT ETANCON	SUPPORT "T"	GEHAEUSE "T"	SCATOLA "T"	
002	421183	002	RONDELLE EPAULEE D.35 EP.10	WASHER WITH SHOULDER	BUCHSE	RONDELLA	
003	80201452	002	ECROU HEX.AUTOFREINE FE/ZNXC3	SELF-LOCKING NUT FE/ZNXC3	SELBSTSICH.MUTTER FE/ZNXC3	DADO AUTOBLOCCANTE FE/ZNXC3	
004	80202420	002	ECROU HEXAG.EMBA.AUOFR.FLZNNC	SELF-LOCKING NUT FLZNNC	SELBSTSICHERNDE MUTTER FLZNNC	DADO AUTOBLOCCANTE FLZNNC	
005	80202047	003	ECROU HEXAG. AUTOFREINE FLZNNC	SELF-LOCKING NUT FLZNNC	SELBSTSICHERNDE MUTTER FLZNNC	DADO AUTOBLOCCANTE FLZNNC	
006	80202447	006	ECROU HEXAGONAL AUTOFREINE	SELF-LOCKING NUT	SELBSTSICHERNDE MUTTER	DADO AUTOBLOCCANTE	
007	80201470	002	ECROU HEXAGONAL FE/ZNXC3	NUT FE/ZNXC3	SECHSKANTMUTTER FE/ZNXC3	DADO FE/ZNXC3	
008	H0400360	002	ETANCON	SHANK	TRAGRAHMEN	TELAIO	
009	H0400350	001	FLASQUE	FLANGE	FLANSCH	FLANGIA	
010	82201016	002	GRAISSEUR AUTOTARAUDANT	SELF TAPPING GREASE NIPPLE	GEWINDESCHNEID-SCHMIERNIPPEL	INGRASSATORE	
011	131208	002	AXE ETANCON	AXLE	ACHSE	PERNO	
012	131209	002	NOIX/SECU./MASTER 100	SPINDLE	KNEBELMUTTER	PERNO	
013	951785	004	RONDELLE PLATE 21X36X3	WASHER 21X36X3	SCHEIBE 21X36X3	RONDELLA	
014	80283680	002	RONDELLE A RESSORT	DISC SPRING	TELLERFEDER	RONDELLA A MOLLA	
015	951991	003	VIS	SCREW	SCHRAUBE	VITE	Q? 1 for disc coultter
016	H0600250	001	BOITE 10 BOULONS SEC.T 14X100	BOX OF 10 BOLTS/NUTS	SCHACHTEL 10 SCHRAUBEN	SERIE 10 BULLONI (VITE+DADO)	

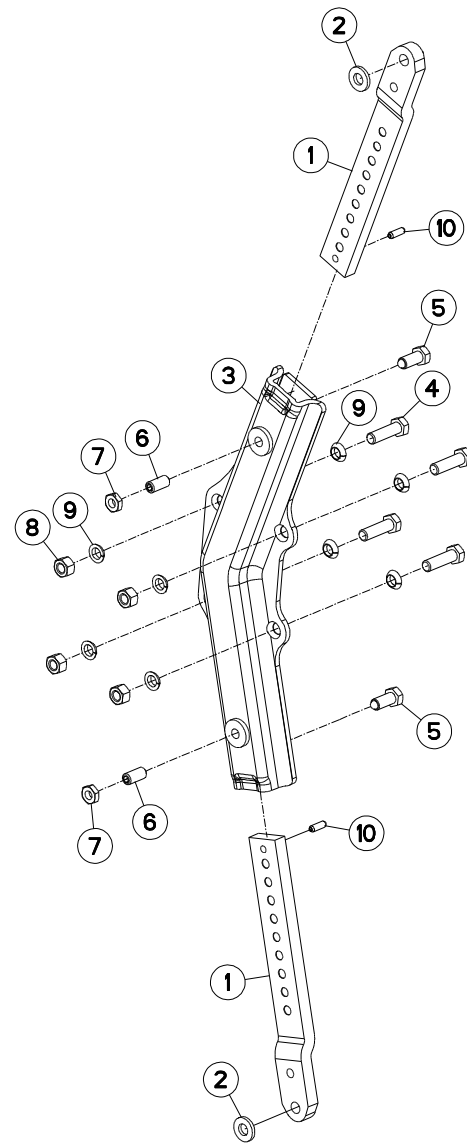



MULTI-MASTER 110T J

J7465 >K9999

H04R0025 B

BOITIER TIGES RASETTE

SKIMMER LEG/SUPPORT

HALTERUNG/VORSCHALESTIEL

GAMBO DEL PREVOMERE

Rep	Nr	Qt	Designation	Description	Bezeichnung	Referenza	Remarque - Remark - Bemerkung - Osservazioni
001	261166	002	TIGE DE RASETTE	SKIMMER LEG	STIEL	BRACCIO AVANVOMERE	
002	422069	002	BAGUE 17 X 35 X 5 PLATE ZNB	WASHER	RING	PARAOLIO	
003	581549	001	BOITIER	HOUSING	GEHAEUSE	SCATOLA	
004	80061647	004	VIS TETE HEXAGONALE FE/ZNXC3	HEXAGON HEAD SCREW FE/ZNXC3	SECHSKANTSCHRAUBE FE/ZNXC3	VITE TESTA ESAGONALE FE/ZNXC3	19daNm 140lbf ft
005	80091640	002	VIS TETE HEX.B.SPHE.FE/ZNXC3	HEXAGON HEAD SCREW FE/ZNXC3	SECHSKANTSCHRAUBE FE/ZNXC3	VITE TESTA ESAGONALE FE/ZNXC3	
006	80151635	002	VIS S/TETE B.PLAT HC FLZNNC	SOCKET SET SCREW FLZNNC	GEWINDESTIFT FLZNNC	VITE FLZNNC	
007	80201601	002	ECROU HEXAGONAL BAS	HEXAGON THIN NUT	FLACHE SECHSKANTMUTTER	DADO	
008	80201670	004	ECROU HEXAGONAL FE/ZNXC3	NUT FE/ZNXC3	SECHSKANTMUTTER FE/ZNXC3	DADO FE/ZNXC3	
009	80271686	008	RONDELLE RESSORT SPHERI.FLZNNC	SPHERICAL SPRING WASHER FLZNNC	FEDERRING FLZNNC	RONDELLA A MOLLA FLZNNC	
010	80450928	002	GOUPILLE ELASTIQUE FLZNNC	ROLL PIN FLZNNC	SPANNHUELSE FLZNNC	SPINA ELASTICA	

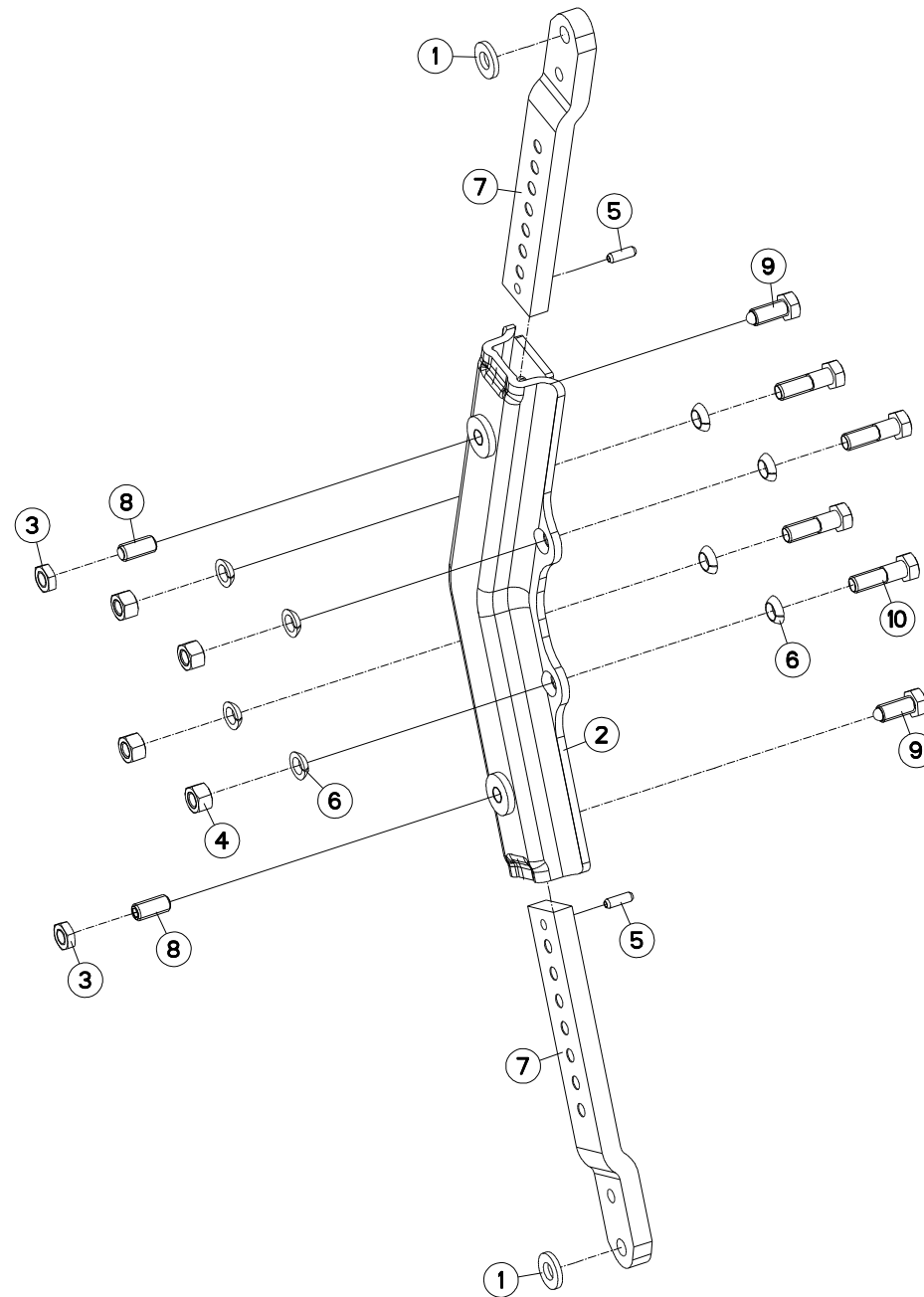



MULTI-MASTER 110T J

J7465 >K9999

H04R0005 B

BOITIER TIGES RASETTE

SKIMMER SUPPORT

VORSCHAELERSTIEL/HALTERUNG

SUPPORTO AVANVOMERE

Rep	Nr	Qt	Designation	Description	Bezeichnung	Referenza	Remarque - Remark - Bemerkung - Osservazioni
001	422069	002	BAGUE 17 X 35 X 5 PLATE ZNB	WASHER	RING	PARAOLIO	
002	582684	001	BOITIER	HOUSING	GEHAEUSE	SCATOLA	
003	80201601	002	ECROU HEXAGONAL BAS	HEXAGON THIN NUT	FLACHE SECHSKANTMUTTER	DADO	
004	80201670	004	ECROU HEXAGONAL FE/ZNXC3	NUT FE/ZNXC3	SECHSKANTMUTTER FE/ZNXC3	DADO FE/ZNXC3	19daN (140lbf ft)
005	80450928	002	GOUPILLE ELASTIQUE FLZNNC	ROLL PIN FLZNNC	SPANNHUELSE FLZNNC	SPINA ELASTICA	
006	80271686	008	RONDELLE RESSORT SPHERI.FLZNNC	SPHERICAL SPRING WASHER FLZNNC	FEDERRING FLZNNC	RONDELLA A MOLLA FLZNNC	
007	261172	002	TIGE	STEM	STANGE	STELO	
008	80151635	002	VIS S/TETE B.PLAT HC FLZNNC	SOCKET SET SCREW FLZNNC	GEWINDESTIFT FLZNNC	VITE FLZNNC	
009	80091640	002	VIS TETE HEX.B.SPHE.FE/ZNXC3	HEXAGON HEAD SCREW FE/ZNXC3	SECHSKANTSCHRAUBE FE/ZNXC3	VITE TESTA ESAGONALE FE/ZNXC3	
010	80061647	004	VIS TETE HEXAGONALE FE/ZNXC3	HEXAGON HEAD SCREW FE/ZNXC3	SECHSKANTSCHRAUBE FE/ZNXC3	VITE TESTA ESAGONALE FE/ZNXC3	

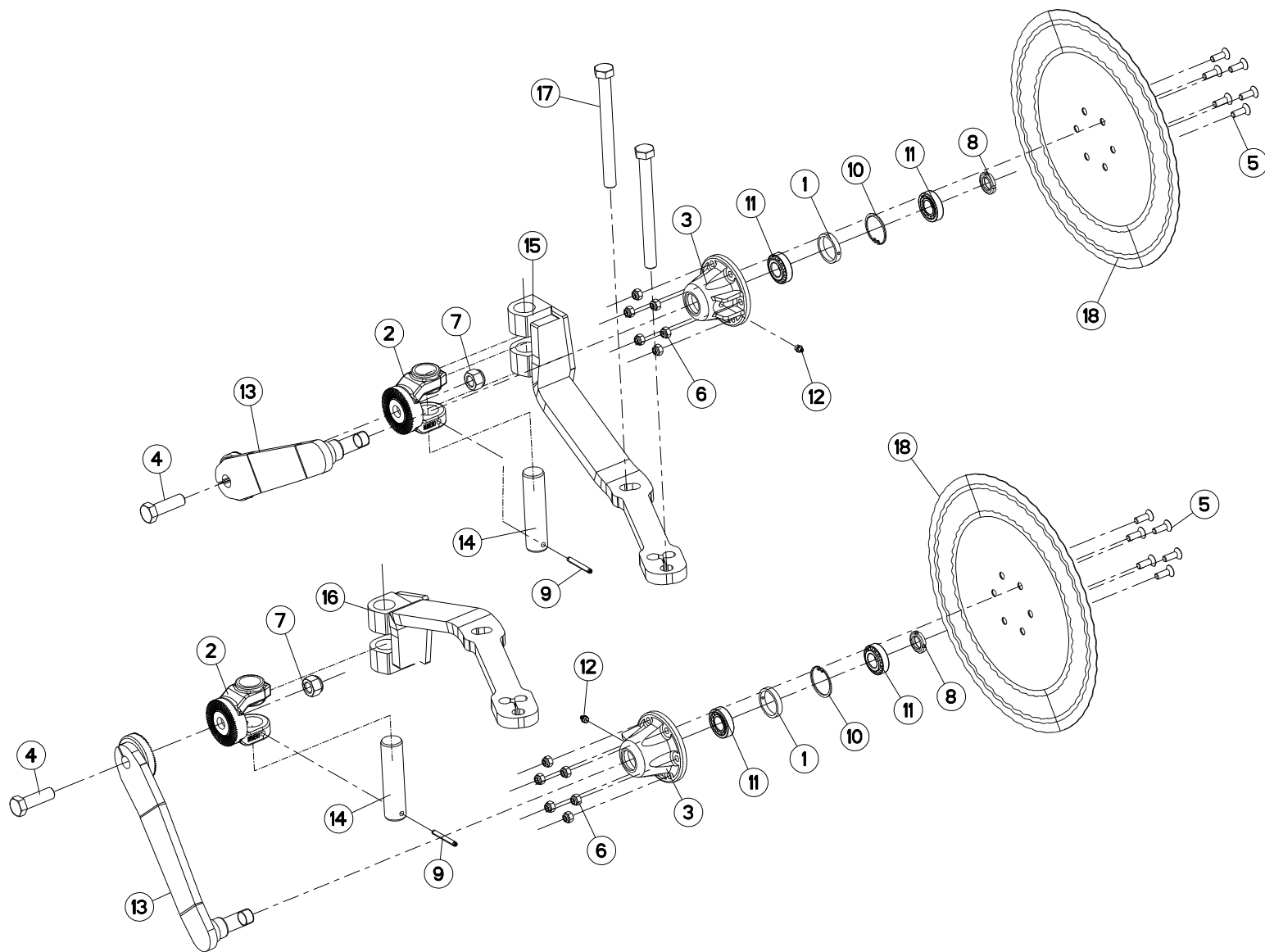



MULTI-MASTER 110T J J7465 >K9999

H04R0003 B

COUTRE CIRCULAIRE

DISC COULTER

SCHEIBENSECH

ASSOLCATORE A DISCO

Rep	Nr	Qt	Designation	Description	Bezeichnung	Referenza	Remarque - Remark - Bemerkung - Osservazioni
001	432023	002	ENTRETOISE	SPACER	DISTANZHUELSE	DISTANZIALE	
002	582575	002	CHAPE	CLEVIS	GABEL	FORCELLA	
003	645226	002	MOYEU NU	HUB	NABE	MOZZO	
004	80062065	002	VIS TETE HEXAGONALE FE/ZNXC3	HEXAGON HEAD SCREW FE/ZNXC3	SECHSKANTSCHRAUBE FE/ZNXC3	VITE TESTA ESAGONALE FE/ZNXC3	
005	80111029	012	VIS T.FRAI.SIX P.CR.FLZNNC	HEX.SOC.COUNT.HEAD SC.FLZNNC	SENKSCHAUB.INNENSEC.FLZNNC	VITE FLZNNC	
006	80201030	012	ECROU HEX.AUTOFREINE FE/ZNXC3	SELF-LOCKING NUT FE/ZNXC3	SELBSTSICH.MUTTER FE/ZNXC3	DADO AUTOBLOCCANTE FE/ZNXC3	
007	80202030	002	ECROU HEX.AUTOFREINE FE/ZNXC3	SELF-LOCKING NUT FE/ZNXC3	SELBSTSICH.MUTTER FE/ZNXC3	DADO AUTOBLOCCANTE FE/ZNXC3	
008	80202518	002	ECROU A ENCOCHES	SLOTTED ROUND NUT	NUTMUTTER	DADO	
009	80440860	002	GOUPILLE SPIRALE	ROLL PIN	SPIRAL-SPANNSTIFTE	SPINA ELASTICA	
010	80595200	002	CIRCLIP INTERIEUR	RETAINING RING	SICHERUNGSRING	ANELLO	
011	81302552	004	ROULEMENT A ROULEAUX CONIQUES	TAPERED ROLLER BEARING	KEGELROLLENLAGER	CUSCINETTO A RULLO	
012	82201016	002	GRAISSEUR AUTOTARAUDANT	SELF TAPPING GREASE NIPPLE	GEWINDESCHNEID-SCHMIERNIPPEL	INGRASSATORE	
013	H0400380	002	BRAS DE CC CAMBRE	DISC ARM	ARM	BRACCIO	
014	H0400390	002	AXE VERTICAL	AXLE	ACHSE	ASSE	
015	H0400420	001	BRAS DE CC ASS. GAUCHE	DISC ARM SUPPORT LEFT	ARM	BRACCIO	
016	H0400430	001	BRAS DE CC ASS. DROIT	DISC ARM SUPPORT RIGHT	ARM	BRACCIO	
017	H0401770	002	VIS	SCREW	SCHRAUBE	VITE	
018	H0400370	002	DISQUE DIAMETRE 460 EP:4MM	DISC D460MM	SCHEIBE	DISCO	

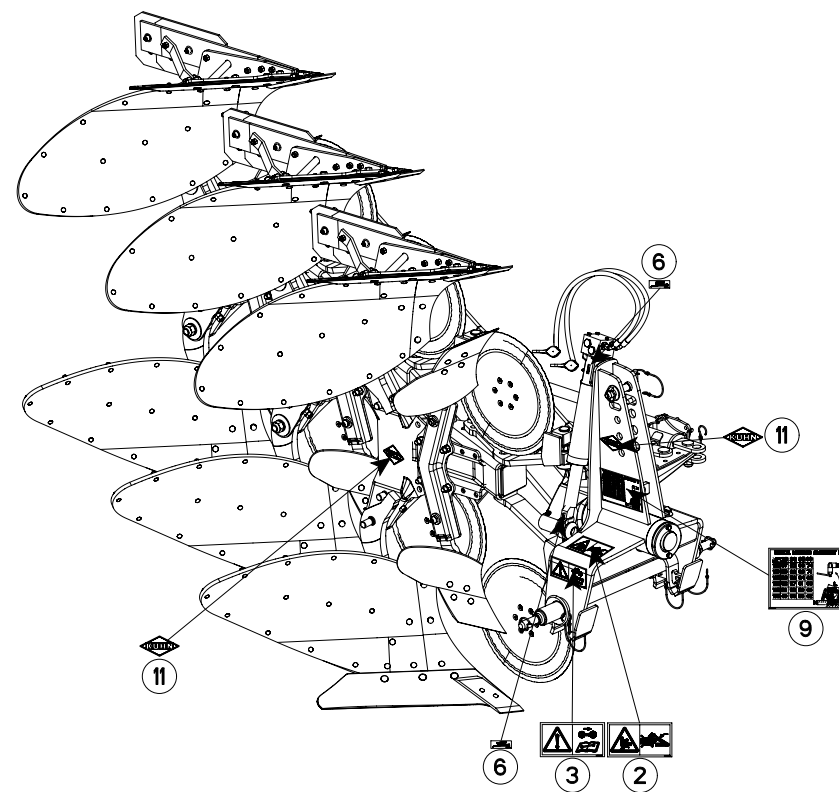
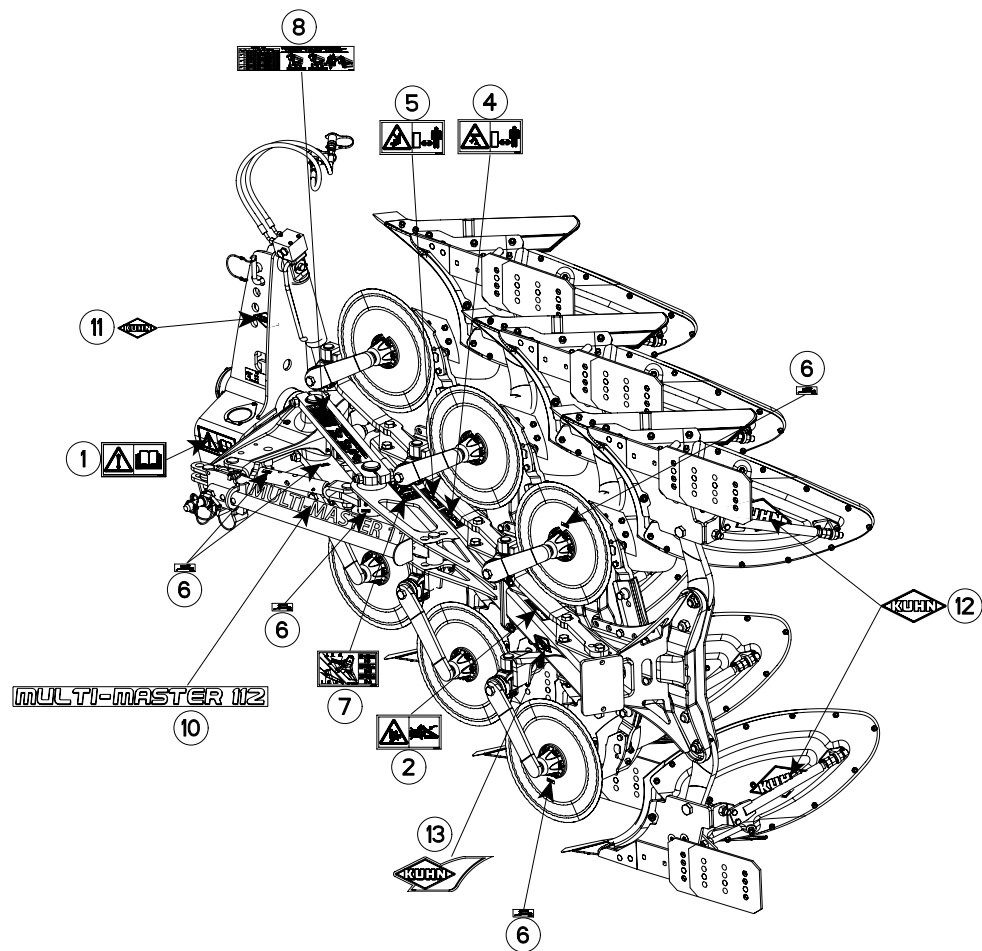



MULTI-MASTER 110T J J7465 >K9999

H15R0023 B

ETIQUETTES ADHESIVES MM112 T

STICKERS MM112 T

AUFKLEBER MM112 T

ADESIVI MM112 T

Rep	Nr	Qt	Designation	Description	Bezeichnung	Referenza	Remarque - Remark - Bemerkung - Osservazioni
001	59900000	001	PICTOGR.H NOTICE D'INSTR	PICTORIAL H INSTRUCTIONS	PIKTOGR.H BETRIEBSANLEITUNG	ADESIVO	
002	59900300	002	PICTOGR.H ECRASEM.MAIN	PICTORIAL H CRUSH.DANGER HAND	PIKTOGR.H QUETSCHGEFAHR HAND	ADESIVO	
003	59900400	001	PICTOGR.H ARRETER MOTEUR	PICTORIAL H STOP ENGINE	PIKTOGR.H MOTOR ABSTELLEN	ADESIVO	
004	59900500	001	PICTOGR.H ECRASEM.CORPS	PICTORIAL H CRUSH. DANGER BODY	PIKTOGR.H QUETSCHGEF.KOERPER	ADESIVO	
005	59900600	001	PICTOGR.H ECRASEM.TORSE	PICTORIAL H CRUSH.DANG.TORSO	PIKTOGR.H QUETSCHGEF.BRUSTK	ADESIVO	
006	950414	001	AUTOCOL.POMPE A GRAISSE	STICKER OIL PUMP	AUFKLEBER SCHMIERUNG	ADESIVO	
007	950562	001	ETIQ.ADHESIVE	DECAL	AUFKLEBER	ADESIVO	
008	H0300210	001	AUTOCOLLANT ENTRE-PNEU	STICKER	AUFKLEBER	ADESIVO	
009	H0333260	001	AUTOCOLLANT APLOMB	STICKER	AUFKLEBER	ADESIVO	
010	K9505750	001	ETIQUETTE ADHESIVE	DECAL	AUFKLEBER	ADESIVO	
011	K9500010	001	LOGO KUHN 103 BLANC/TRANSP.	LOGO KUHN 103	LOGO KUHN 103	LOGO KUHN 103 BIANCO TRASP	
012	K9500070	001	LOGO KUHN 207 BLANC/TRANSP.	LOGO KUHN 207	LOGO KUHN 207 WEISS/TRANSP.	LOGO KUHN 207 BIANCO TRASP.	
013	K9530260	001	ETIQ.ADH.	DECAL	AUFKLEBER	ADESIVO	

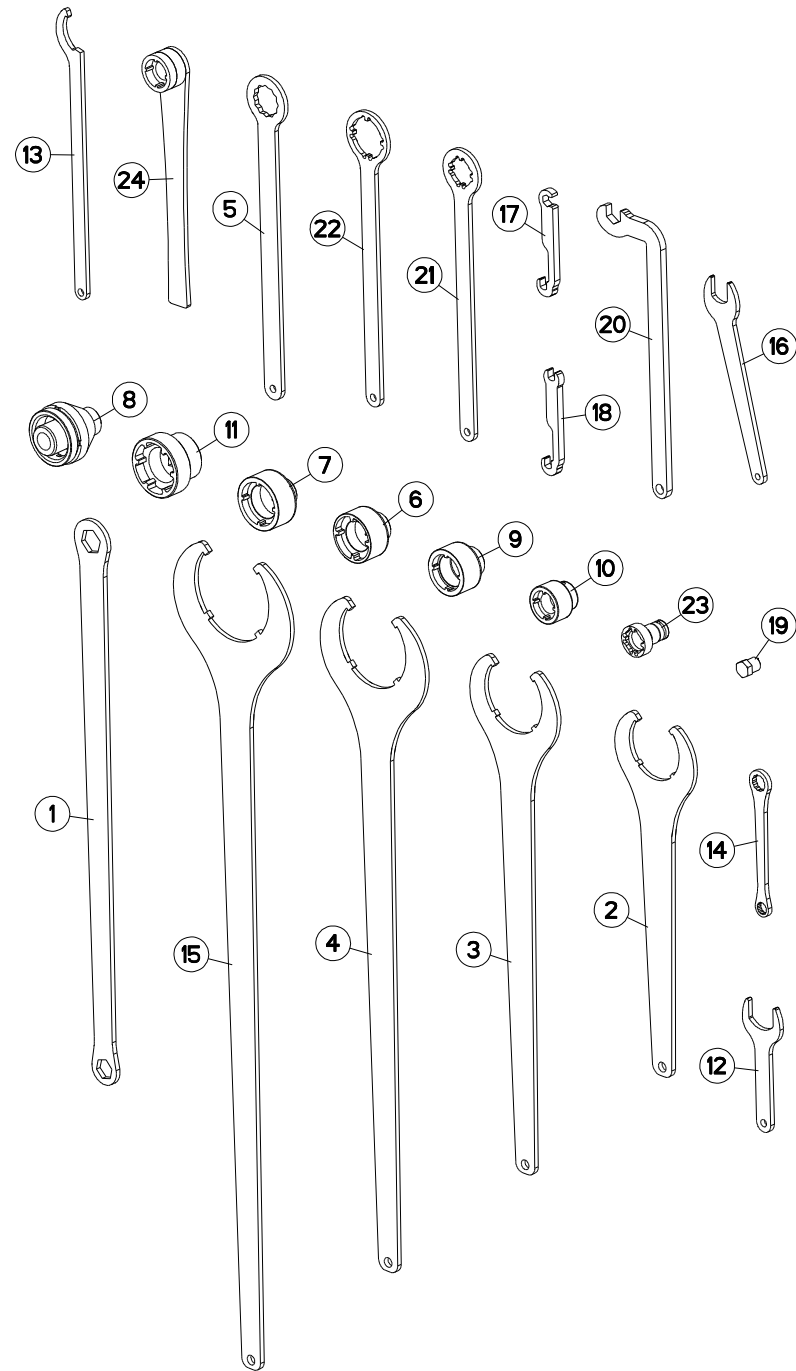



MULTI-MASTER 110T J J7465 >K9999

H24R0248 A

OUTILLAGE

TOOLS

WERKZEUG

ATTREZZI

Rep	Nr	Qt	Designation	Description	Bezeichnung	Referenza	Remarque - Remark - Bemerkung - Osservazioni
001	211664	001	CLE 30/36	SPANNER 30/36	SCHLUESSEL 30/36	CHIAVE	: M20 ; M24
002	211828	001	CLE SPECIALE	SPANNER	SCHLUESSEL	CHIAVE	: KM M80 ; 971101
003	211829	001	CLE SPECIALE	SPANNER	SCHLUESSEL	CHIAVE	: KM M90 ; 951115
004	211830	001	CLE SPECIALE	SPANNER	SCHLUESSEL	CHIAVE	: KM M105 ; 951180
005	780104	001	CLE A OEIL 46/PLATS	SPANNER 46		CHIAVE	: M30
006	3104124	001	DOUILLE	SPECIAL SOCKET->80204519	SPEZIAL STECKNUSS	CHIAVE SPECIALE	: KM M10 ; 80204519 ; 80204566
007	3119467	001	DOUILLE	SPECIAL SOCKET	SPEZIAL-STECKNUSS	CHIAVE SPECIALE	: KM M50 ; 50019600
008	3125420	001	DOUILLE SERR./ENCOCHES:M72X2,0	SPECIAL SOCKET->52502300	SPEZIAL STECKNUSS	CHIAVE SPECIALE	: 5250230
009	3125587	001	DOUILLE SERR./ENCOCHES:M40X1,5	SPECIAL SOCKET->80204063	SPEZIAL STECKNUSS	CHIAVE SPECIALE	: KM M40 ; 80204063
010	3157109	001	DOUILLE SERR./ENCOCHES:M30X1,5	SPECIAL SOCKET->80203065	SPEZIAL STECKNUSS	CHIAVE SPECIALE	: KM M30 ; 80203065
011	3177802	001	DOUILLE SERR./ENCOCHES:M55X2,0	SPECIAL SOCKET->80205519	SPEZIAL-STECKNUSS	CHIAVE SPECIALE	: KM M55 ; 80205519
012	H0301420	001	CLE	WRENCH	SCHLUESSEL	CHIAVE	: M33 ; H0201280
013	H0333500	001	CLE A ERGOTS	SPANNER	SCHLUESSEL	CHIAVE	: KM M25 ; H0333270
014	H0600040	001	CLE 18 / 24	SPANNER	SCHLUESSEL	CHIAVE	: M12 ; M16
015	H0600770	001	CLE SPECIALE	SPANNER	SCHLUESSEL	CHIAVE	: KM M120 ; 951813
016	H0600780	001	CLE SPECIALE	SPANNER	SCHLUESSEL	CHIAVE	: M22
017	H0600790	001	CLE SPECIALE	SPANNER	SCHLUESSEL	CHIAVE	: A4083100
018	H0600800	001	CLE SPECIALE	SPANNER	SCHLUESSEL	CHIAVE	: A4083100
019	H0600810	001	CLE BLOC POWER PACKER	SPANNER	SCHLUESSEL	CHIAVE	: BLOC POWER PACKER
020	H0600960	001	CLE SPECIALE (CHAISE HX-1ER PR	SPANNER	SCHLUESSEL	CHIAVE	: M20 ; 80202040
021	H0602770	001	CLE	WRENCH	SCHLUESSEL	CHIAVE	: KM M30 ; 80203018
022	H0602780	001	CLE	WRENCH	SCHLUESSEL	CHIAVE	: KM M45 ; 80204517
023	H2219020	001	EMBOUT	END PIECE	ENDSTUECK	GIUNTO	: KM M25 ; 80202566
024	H2400640	001	CLE SPECIALE (POUR ECROU MCR 3	SPANNER	SCHLUESSEL	CHIAVE	: KM30 ; 80203066



INDEX NUMERIQUE - NUMERICAL INDEX TEILENUMMERN-INDEX - INDICE NUMERICO

Nr	Page	Rep.	Nr	Page	Rep.	Nr	Page	Rep.	Nr	Page	Rep.	Nr	Page	Rep.	Nr	Page	Rep.	Nr	Page	Rep.
A4074017	003	016	H0600800	025	018	645226	021	003	80450928	017	010									
A4921115	003	018	H0600810	025	019	645300	007	005	80450928	019	005									
A4921115	003	019	H0600960	025	020	720037	007	006	80541260	007	011									
H0100080	003	003	H0601480	003	010	720038	009	001	80586000	007	012									
H0100380	003	023	H0602770	025	021	720039	009	002	80595200	021	010									
H0100390	003	024	H0602780	025	022	750079	009	016	81302552	021	011									
H0100720	007	014	H2219020	025	023	750084	009	010	82200616	009	013									
H0101490	003	001	H2400640	025	024	780104	025	005	82201016	003	002									
H0102140	007	015	K9500010	023	011	80060681	003	015	82201016	007	013									
H0102150	007	016	K9500070	023	012	80061016	007	007	82201016	011	002									
H0200270	011	001	K9505750	023	010	80061637	013	004	82201016	015	010									
H0200380	013	003	K9530260	023	013	80061647	017	004	82201016	021	012									
H0300150	007	017	116042	007	001	80061647	019	010	82300026	003	017									
H0300160	009	017	131208	015	011	80062065	021	004	83070064	003	009									
H0300170	009	007	131209	015	012	80062086	007	008	83070064	005	005									
H0300180	009	008	211664	025	001	80091640	017	005	83070064	009	014									
H0300190	009	005	211828	025	002	80091640	019	009	900210	003	006									
H0300200	007	018	211829	025	003	80111029	021	005	900331	003	021									
H0300210	023	008	211830	025	004	80151635	017	006	900473	003	012									
H0300230	009	015	261166	017	001	80151635	019	008	900474	003	013									
H0300240	009	006	261172	019	007	80190616	003	008	900483	003	022									
H0300530	003	011	3104124	025	006	80201030	021	006	950414	023	006									
H0300540	003	020	3119467	025	007	80201452	015	003	950562	023	007									
H0301420	025	012	3125420	025	008	80201470	015	007	951785	015	013									
H0301680	007	017	3125587	025	009	80201601	017	007	951991	015	015									
H0301690	007	018	3157109	025	010	80201601	019	003												
H0333260	023	009	3177802	025	011	80201647	013	001												
H0333500	025	013	421183	015	002	80201669	013	002												
H0400331	015	001	421249	007	002	80201670	017	008												
H0400350	015	009	422069	017	002	80201670	019	004												
H0400360	015	008	422069	019	001	80202030	021	007												
H0400370	021	018	432023	021	001	80202047	007	009												
H0400380	021	013	490025	007	003	80202047	015	005												
H0400390	021	014	490063	007	004	80202420	015	004												
H0400420	021	015	541001	005	001	80202440	009	011												
H0400430	021	016	541001	009	012	80202447	015	006												
H0401770	021	017	545069	005	002	80202518	021	008												
H0600000	009	004	580296	005	003	80252432	003	005												
H0600010	009	003	581549	017	003	80252755	005	004												
H0600040	009	009	582575	021	002	80270684	003	014												
H0600040	025	014	582684	019	002	80271084	007	010												
H0600250	015	016	59900000	023	001	80271686	017	009												
H0600650	003	007	59900300	023	002	80271686	019	006												
H0600770	025	015	59900400	023	003	80283680	015	014												
H0600780	025	016	59900500	023	004	80440860	021	009												
H0600790	025	017	59900600	023	005	80450762	003	004												

EXTRAIT DES CONDITIONS DE GARANTIE ET CONDITIONS SPECIFIQUES PIECES DE RECHANGE

Nous garantissons notre matériel durant une année à partir du jour de livraison, c'est-à-dire que nous nous engageons à rembourser les pièces qui auront été reconnues défectueuses en nos usines, par notre service technique.

Bien entendu, la garantie ne s'applique pas en cas d'usure normale, ni en cas de détériorations résultant de négligences ou de défauts de surveillance, d'un mauvais usage, d'un manque d'entretien ou d'un accident. La garantie ne s'applique pas non plus si la machine a été prêtée ou utilisée pour un usage non conforme à sa destination prévue par la société.

La garantie ne s'applique pas aux pièces d'usure.

Les pièces de rechange sont soumises aux mêmes conditions de garantie que le matériel sous réserve qu'elles aient été montées selon les règles de l'art et utilisées conformément à nos recommandations.

EXTRACT FROM OUR CONDITIONS OF LIMITED WARRANTY AND SPARE PARTS WARRANTY POLICY

Our equipment is warranted for a period of one year from the date of delivery. We guarantee the reimbursement of all parts proven to be faulty by our technical division in material or manufacturing.

The warranty is not applicable in the following cases : normal wear, accident or negligence in operation, repairs using parts other than genuine KUHN parts, products altered or modified without the expressed permission of the company or if the machine is not used and serviced in accordance with the recommendations of the operator's manual. Wearing items are not covered under these conditions of limited warranty.

Spare parts are subject to the same warranty conditions than the equipment providing they have been installed with proficiency and are used in accordance with our recommendations.

AUSZUG AUS UNSEREN GARANTIEBEDINGUNGEN UND SONDERBEDINGUNGEN FÜR ERSATZTEILE

Wir garantieren unsere Ware für ein Jahr ab dem Tag der Lieferung und verpflichten uns, die Teile zu ersetzen, die im Werk als fehlerhaft anerkannt wurden.

Die Garantie ist ausgeschlossen für Teile, die einem normalen Verschleiß unterliegen, sowie im Fall von nachlässiger Behandlung oder mangelhafter Wartung oder eines Unfalls. Die Garantie erlischt auch, wenn die Maschine ausgeliehen oder unter Umständen eingesetzt wurde, die dem ursprünglichen Verwendungszweck und den Hinweisen in der Betriebsanleitung nicht entsprechen.

Verschleißteile sind von der Garantie ausgeschlossen

Ersatzteile unterliegen den gleichen Garantiebedingungen wie komplette Maschinen, vorausgesetzt, dass sie sachgerecht eingebaut und entsprechend unseren Empfehlungen verwendet wurden.

ESTRATTO DELLE CONDIZIONI DI GARANZIA E CONDIZIONI SPECIFICHE GARANZIA RICAMBI

Le nostre macchine sono garantite per un anno a partire dal giorno della consegna: ci impegnamo a rimborsare i componenti che saranno riconosciuti difettosi dai nostri servizi tecnici presso le nostre officine.

La garanzia non è applicabile nei seguenti casi: usura normale, incidente o negligenza nell'impiego, riparazioni utilizzando ricambi non originali KUHN, prodotti alterati o modificati senza il permesso dell'azienda. La garanzia non viene riconosciuta se la macchina è stata prestata o non è utilizzata o mantenuta in conformità alle raccomandazioni previste dalla società. La garanzia non copre i componenti soggetti ad usura.

I pezzi di ricambio sono soggetti agli stessi termini di garanzia della macchina, purchè siano stati installati con competenza e utilizzati conformemente alle nostre raccomandazioni.



**Pour votre sécurité et le bon fonctionnement de votre machine,
utilisez uniquement des pièces d'origine KUHN**

**For your safety and to get the best from your machine,
use only genuine KUHN parts**

**Zu ihrer Sicherheit und zur einwandfreien Funktion Ihrer
Maschine sollten Sie nur Original-KUHN-Ersatzteile verwenden**

**Per la vostra sicurezza, e per il buon funzionamento della vostra macchina,
usate esclusivamente i ricambi originali KUHN**

KUHN PARTS Parc de la Faisanderie F - 67700 MONSWILLER (FRANCE)

Tél.: + 33 (0) 3 88 01 81 00 - Fax : + 33 (0) 3 88 01 81 03

www.kuhn.com

Imprimé en France par KUHN
Printed in France by KUHN