

Pièces de rechange
Spare parts list
Ersatzteilliste
Catalogo Pezzi di Ricambio

Girofaucheuse
 Multidisc Mower
 Scheibenmäher
 Falciatrice

B 0001 > C 0000

GMD 2820F 540 / 1000







SIGNES CODIFIÉS - STANDARD SYMBOLS - SYMBOLE - SIMBOLI CODIFICATI

	EN	FR	DE	IT	PT	ES	NL	PL
OPT	Optional equipment	Equipement optionnel	Sonderausrüstung	Attrezzatura opzionale	Equipamento opcional	Equipamiento opcional	Extra toebehoren	Wyposażenie dodatkowe
STD	Equipment supplied as standard	Equipement livré de série	Serienausrüstung	Attrezzatura fornita di serie	Equipamento fornecido como padrão	Equipamiento entregado de serie	Standaarduitrusting	Wyposażenie dostarczane w standardzie
ESP	Equipment delivered depending on country	Equipement livré suivant pays	Länderabhängige Ausrüstung	Attrezzatura fornita a seconda del paese	Equipamento fornecido consoante o país	Equipamiento entregado según el país	Geleverde uitrusting afhankelijk van land	Wyposażenie dostarczane w zależności od kraju
:	For ...	Pour ...	für ...	per ...	Por ...	Para ...	voor ...	Dla ...
>	From ... to ...	De ... à ...	Von ... bis ...	Da ... a ...	De ... a ...	De ... a ...	Van ... tot ...	Od ... do ...
RPL	Replaces ...	Remplace ...	Ersetzt ...	Sostituisce ...	Substituição ...	Sustitución ...	Vervangt ...	Zastępuje ...
∅	Diameter	Diamètre	Durchmesser	Diametro	Diâmetro	Diámetro	Diameter	Średnica
>K	Thickness	Epaisseur	Stärke	Spessore	Espessura	Espesor	Dikte	Grubość
↔	Length	Longueur	Länge	Lunghezza	Comprimento	Longitud	Lengte	Długość
<m>	Sold by the metre	Vendu au mètre	Meterware	Venduto a metro	Vendido por metro	Vendido al metro	Verkoop per meter	Sprzedaż na metry
Q?	Quantity as required	Quantité selon besoin	Stückzahl nach Bedarf	Quantità richiesta	Quantidade conforme requerido	Cantidad según necesidad	Gewenste hoeveelheid	Wymagana ilość
*	See note	Voir note	Siehe Nota	Vedi nota	Veja a nota	Ver nota	Zie opmerking	Patrz uwaga
[n]	Items making up assembly	Composant d'un assemblage	Teil einer Baugruppe	Componente di un assieme	Componentes do uno montagem	Componente de un montaje	Onderdeel van een module	Elementy składowe Montaż
+ [n]	Assembly made up by items [n]	Assemblage comprenant les pièces [n]	Baugruppe bestehend aus den mit [n] bezeichneten	Assieme comprendente i componenti [n]	A montagem compreende as peças [n]	El montaje comprende las piezas [n]	Module bestaande uit alle onderdeel [n]	Elementy składowe zestawu montażowego części [n]
<-]	Left part	Pièce gauche	Linker Teil	Parte sinistra	Parte esquerda	Parte izquierda	Linker gedeelte	Lewa część
[>	Right part	Pièce droite	Rechter Teil	Parte destra	Parte direita	Parte derecha	Rechter gedeelte	Prawa część
z	Number of teeth	Nombre de dents	Anzahl der Zinken	Numero di denti	Número de dentes	Número de dientes	Aantal tanden	Liczba zębów

	EN	FR	DE	IT	PT	ES	NL	PL
	<p>WHEN ORDERING SERVICE-PARTS, PLEASE MENTION:</p> <ul style="list-style-type: none"> The machine type and serial number The part number The quantity of parts 	<p>POUR COMMANDER DES PIÈCES DE RECHANGE, VEUILLEZ INDICHER:</p> <ul style="list-style-type: none"> Le numéro de fabrication de la machine Le numéro de la pièce La quantité désirée 	<p>BEI DER BESTELLUNG VON ERSATZTEILEN IMMER ANGEBEN:</p> <ul style="list-style-type: none"> Die Seriennummer der Maschine Die Nummer des Teiles Die gewünschte Stückzahl 	<p>NELL'ORDINARE I RICAMBI, SI PREGA DI INDICARE:</p> <ul style="list-style-type: none"> Il tipo ed il numero di serie della macchina Il codice del componente La quantità desiderata 	<p>QUANDO PEDIR POR PEÇAS/SERVIÇOS, POR FAVOR INDIQUE:</p> <ul style="list-style-type: none"> O tipo de máquina e número de série O código da peça A quantidade de peças 	<p>PARA PEDIR LAS PIEZAS DE REPUESTO, POR FAVOR INDIQUE:</p> <ul style="list-style-type: none"> O número de fabricación de la máquina El número de la pieza La cantidad deseada 	<p>VERMELD BIJ HET BESTELLEN VAN ONDERDELEN ALTIJD:</p> <ul style="list-style-type: none"> het serienummer van de machine het nummer van het onderdeel de gewenste hoeveelheid 	<p>PRZY ZAMAWIANIU CZĘŚCI SERWISOWYCH, PROSIMY PODAJ:</p> <ul style="list-style-type: none"> Typ maszyny i numer seryjny Numer części Ilość części

	<p>Service parts and service part assemblies are to be ordered through the spare parts department.</p> <p>• Optional equipment (OPT) and assembly operator's manuals should be ordered through the wholegood sales department.</p>	<p>Toutes les pièces détachées et sous-ensembles sont à commander au magasin pièces de rechange.</p> <p>• Les équipements optionnels (OPT) ainsi que les notices d'instructions sont à commander auprès des services commerciaux.</p>	<p>Bestellungen für Ersatzteile und Baugruppen sind an die Ersatzteilabteilung zu richten.</p> <p>• Sonderausrüstungen (OPT) sowie Montage- und Betriebsanleitungen, bestellen Sie bitte bei der Verkaufsabteilung für Maschinen.</p>	<p>I ricambi e i sotto-assieme devono essere ordinati al Magazzino Ricambi.</p> <p>• Le attrezzature opzionali (OPT) ed i manuali dell'operatore devono essere ordinati al Servizio Commerciale.</p>	<p>Peças e conjuntos de peças devem ser pedidos através do departamento de peças de reposição.</p> <p>• Os equipamento opcionais (OPT) e manuais de montagem devem ser pedidos através do departamento comercial.</p>	<p>Todas las piezas separadas y los sub-conjuntos tienen que pedirse en la tienda de recambios.</p> <p>• Los equipamientos opcionales (OPT) y los manuales de uso se piden en los servicios comerciales.</p>	<p>Bestellingen van onderdelen en modules moeten gericht worden aan de Onderdelenafdeling.</p> <p>• Extra toebehoren (OPT) en handleidingen kunt u bestellen bij de verkoopafdeling van machines.</p>	<p>Części serwisowe i montaż części serwisowych muszą być zamawiane za pośrednictwem działu części zamiennych.</p> <p>• Wyposażenie dodatkowe (OPT) i instrukcje montażu powinny być zamawiane za pośrednictwem działu sprzedaży.</p>
--	---	--	--	---	--	---	--	--

	<p>When replacing or changing parts, be sure to also order and apply all decals required on them, especially those on safety procedures.</p>	<p>Lors du remplacement ou d'un changement de pièces, commander et apposer impérativement toutes les étiquettes et notamment de sécurité.</p>	<p>Wenn Sie Teile ersetzen oder auswechseln, bestellen Sie alle selbstklebenden Etiketten, insbesondere diejenigen, die die Sicherheit betreffen, und bringen Sie sie an.</p>	<p>In caso di sostituzione o cambio pezzi, ordinare e apporre imperativamente tutti gli autoadesivi, in particolare quelli relativi alla sicurezza.</p>	<p>Quando substituir ou trocar peças, encomende e certifique-se que são colocados os autocolantes, especialmente aqueles relacionados à segurança.</p>	<p>Al sustituir o cambiar piezas, encargar pegatinas autoadhesivas y asegurarse de pegarlas, especialmente las relativas a la seguridad.</p>	<p>Zorg er bij het vervangen of verwisselen van onderdelen voor dat alle stickers, vooral die de veiligheid betreffen, op de juiste plaats zitten, bestel zonodig nieuwe stickers.</p>	<p>Podczas montażu i wymiany części należy pamiętać o zamówieniu i założeniu wszystkich elementów samoprzylepnych, szczególnie jeśli stanowią one część zabezpieczeń maszyny.</p>
--	--	---	---	---	--	--	--	---

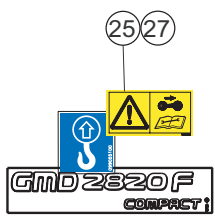
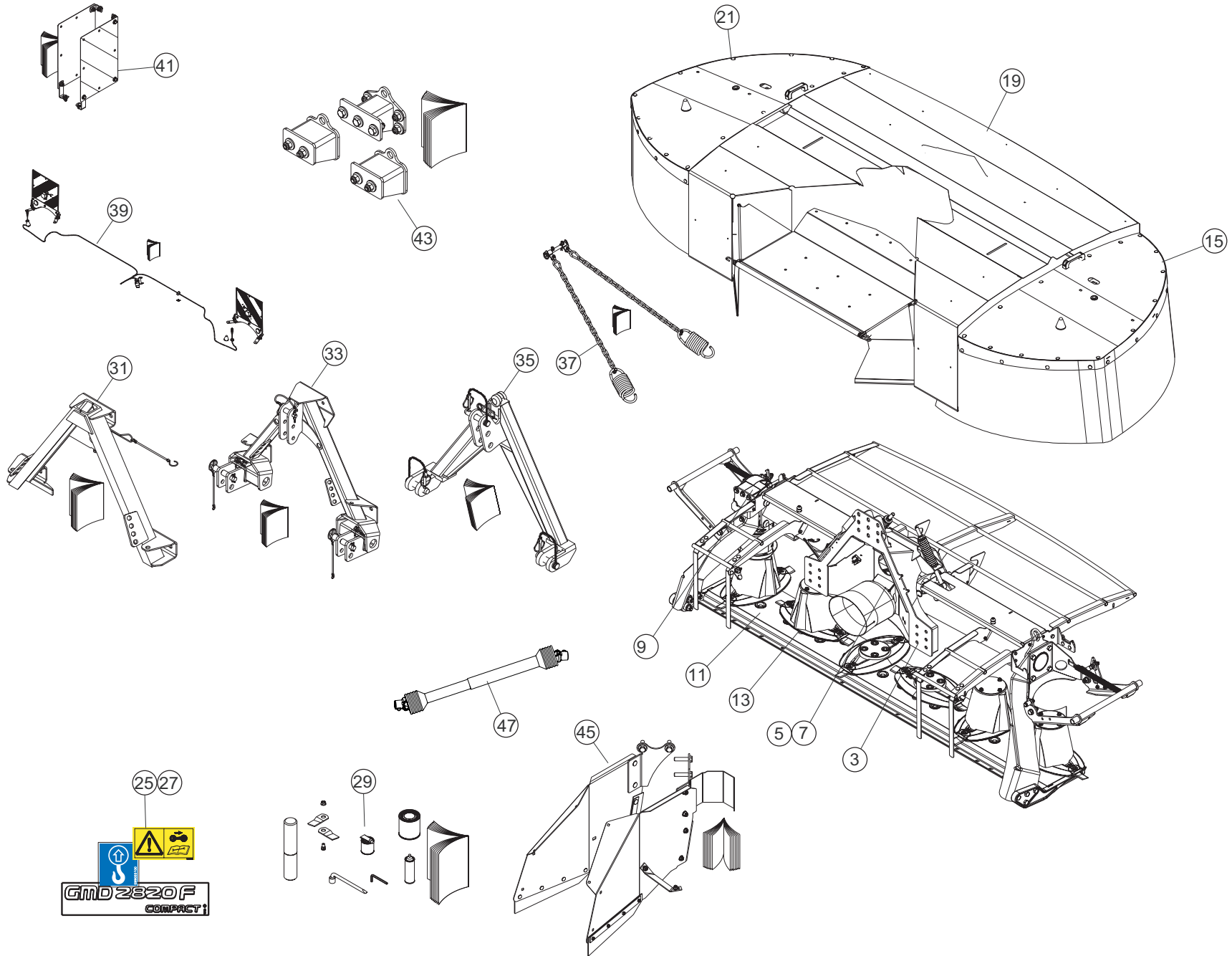



TABLE DES MATIERES - TABLE OF CONTENTS - INHALTSVERZEICHNIS - INDICE

K70R0669 D

Catalogue P.D.R. - Spare parts list - Ersatzteilliste - Pezzi di Ricambio :

KR154BTL D

Annule et remplace - Cancels and replaces - Annulliert und ersetzt - Annulla e sostituisce :

KR154BTL C

Grp	Page	Opt	Groupe de pièces	Parts group index	Teilegruppe	Gruppo di parti
003	003		CHASSIS	FRAME	RAHMEN	TELAIO
005	005		CARTER CENTRAL 1000	CENTRAL GEARBOX 1000	HAUPTGETRIEBE 1000	SCATOLA CENTRALE 1000
007	007		CARTER CENTRAL 540	CENTRAL GEARBOX 540	HAUPTGETRIEBE 540	SCATOLA CENTRALE 540
009	009		CARTER LATERAL	SIDE GEARBOX	SEITENGETRIEBE	RIDUTTORE LATERALE
011	011		CARTER DU PORTE - DISQUES	CUTTERBAR GEAR CASE	MÄHBALKEN	SCATOLA INGRAN. BARRA COLTELLI
013	013		DISQUES	DISCS	SCHEIBEN	DISCHI
015	015		PROTECTEURS (DROITE)	SAFETY GUARDS (RIGHT)	SCHUTZVORRICHTUNGEN (RECHTS)	PARAPETTI (DX)
019	019		PROTECTEURS	SAFETY GUARDS	SCHUTZVORRICHTUNGEN	PARAPETTI
021	021		PROTECTEURS (GAUCHE)	SAFETY GUARDS (LEFT)	SCHUTZVORRICHTUNGEN (LINKS)	PARAPETTI (SX)
025	025		COLL.ETIQUETTES ADHESIVES	SET OF STICKERS	SATZ AUFKLEBER	SERIE ADESIVI
027	027		COLL.ETIQUETTES ADHESIVES	SET OF STICKERS	SATZ AUFKLEBER	SERIE ADESIVI
029	029		DIVERS	MISCELLANEOUS	VERSCHIEDENES	VARIE
031	031	OPT	TRIANGLE D'ATTELAGE	ATTACHMENT FRAME	ANBAUDREIECK	ATTACO A TRE PUNTI
033	033	OPT	CADRE 3 POINTS	3 POINT FRAME	DREIPUNKTBOCK	TIMONE
035	035	OPT	TRIANGLE D'ATTELAGE	ATTACHMENT FRAME	ANBAUDREIECK	ATTACO A TRE PUNTI
037	037	OPT	RESSORT DE COMPENSATION	COMPENSATION SPRING	ENTLASTUNGSFEDER	MOLLA DE COPENSAZIONE
039	039	OPT	SIGNALISATION	SIGNALLING	BELEUCHTUNG U.WARNTAFELN	SEGNALAZIONE
041	041	OPT	SIGNALISATION LATERALE	SIDE SIGNALLING	SEITLICHE WARNTAFELN	SEGNALAZIONE LATERALI
043	043	OPT	DEPORT 120 MM	OFF SETTING 120 MM	VORDERFURCHEINSTELLUNG 120 MM	SFALSAMENTO 120 MM
045	045	OPT	TOLES A ANDAINS	SWATH BOARDS	SCHWADBLECHE	LAMIERE PER ANDANE
047	047		TRANSMISSION 4800618	TRANSMISSION 4800618	GELENKWELLE 4800618	TRANSMISSIONE 4800618

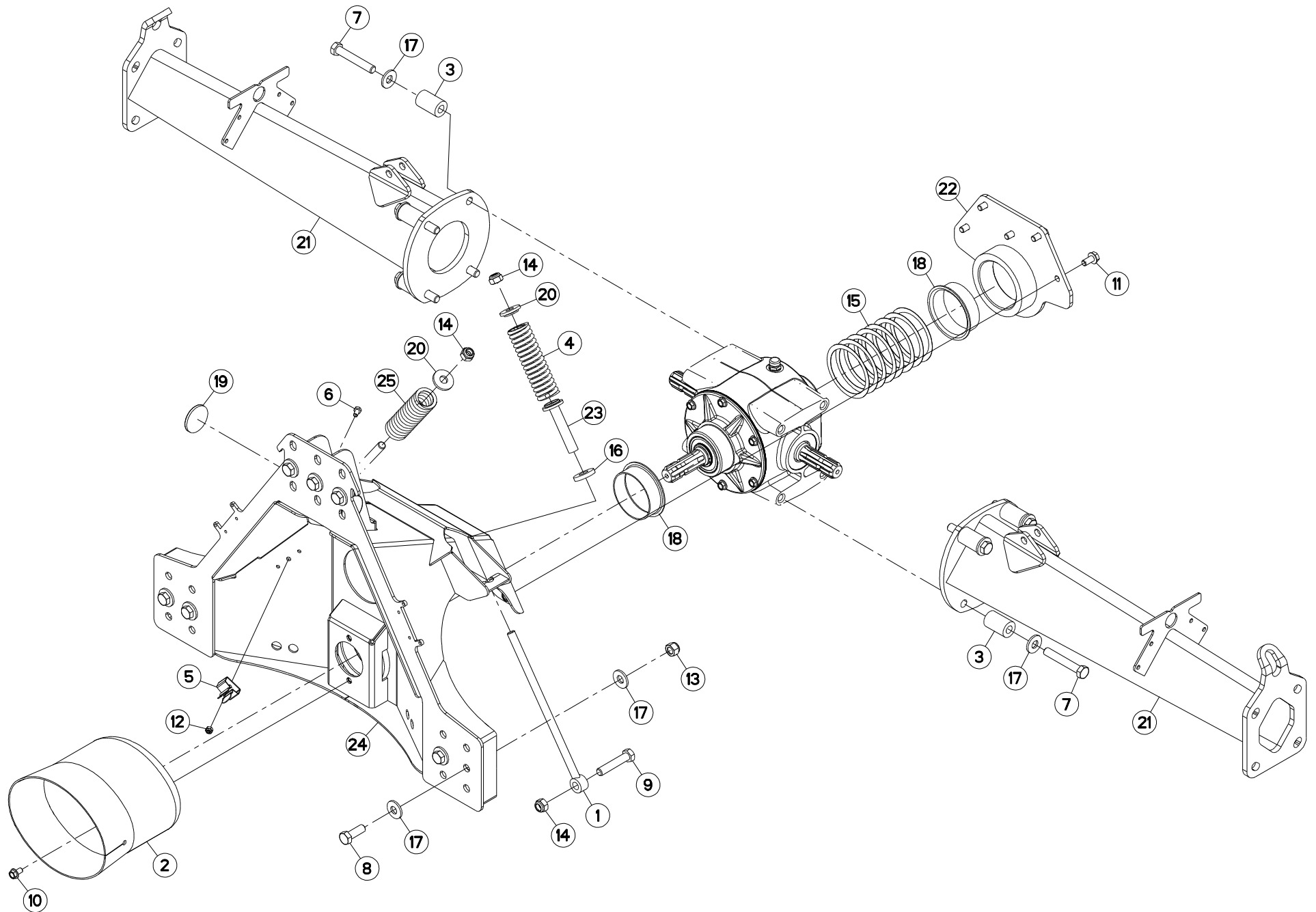



GMD2820F 1000
GMD2820F 540

B 0001 > C 0000
B 0001 > C 0000

K70R0721 B

CHASSIS

FRAME

RAHMEN

TELAIO

Rep	Nr	Qt	Designation	Description	Bezeichnung	Referenza	Remarque - Remark - Bemerkung - Osservazioni
001	55729010	002	TIGE	STEM	STANGE	STELO	
002	56696400	001	BOL PLASTIQUE AVEC MANCHON	SAFETY SHIELD WUTH EXTENSION	SCHUTZTOPF MIT MANSCHETTE	CALOTTA CON PROLONGA	
003	57522400	008	ENTRETOISE ZBC	SPACER	DISTANZHUELSE	DISTANZIALE	
004	58733700	001	RESSORT DE PRESSION ZBC	PRESSURE SPRING ZBC	FEDER ZBC	MOLLA DI PRESSIONE ZBC	
005	59402900	001	RESSORT	SPRING	FEDER	MOLLA	
006	80060816	001	VIS TETE HEXAGONALE FE/ZNXC3	HEX. SCREW FE/ZNXC3	SECHSKANTSCHRAUBE FE/ZNXC3	VITE TESTA ESAGONALE FE/ZNXC3	
007	80061681	008	VIS TETE HEXAGONALE FLZNNC	HEXAGON HEAD SCREW FLZNNC	SECHSKANTSCHRAUBE FLZNNC	VITE TESTA ESAGONALE FLZNNC	
008	80061646	007	VIS TETE HEXAGONALE FE/ZNXC3	HEXAGON HEAD SCREW FE/ZNXC3	SECHSKANTSCHRAUBE FE/ZNXC3	VITE TESTA ESAGONALE FE/ZNXC3	
009	80061657	002	VIS TETE HEXAGONALE FE/ZNXC3	HEXAGON HEAD SCREW FE/ZNXC3	SECHSKANTSCHRAUBE FE/ZNXC3	VITE TESTA ESAGONALE FE/ZNXC3	
010	80131018	002	VIS AUTOBLOQUANTE	UNDERSERRATED S-LOCKING SCREW	SPERRZAHN-BUNDSCHRAUBE	VITE	
011	80131225	005	VIS AUTOBLOQUANTE FLZNNC	UNDERSERR.S-LOC.SCREW FLZNNC	SPERRZAHN-BUNDSCHRAU.FLZNNC	VITE FLZNNC	
012	80200840	001	ECROU HEX.BAS AUTOFR.FE/ZNXC3	SELF-LOCKING NUT FE/ZNXC3	SELBSTSICHERND.MUTTER FE/ZNXC3	DADO AUTOBLOCCANTE FE/ZNXC3	
013	80201630	007	ECROU HEX.AUTOFREINE FE/ZNXC3	SELF-LOCKING NUT FE/ZNXC3	SELBSTSICH.MUTTER FE/ZNXC3	DADO AUTOBLOCCANTE FE/ZNXC3	
014	80201640	004	ECROU HEX.BAS AUTOFR.FE/ZNXC3	SELF-LOCKING NUT FE/ZNXC3	SELBSTSICHERND.MUTTER FE/ZNXC3	DADO AUTOBLOCCANTE FE/ZNXC3	
015	80250006	008	RONDELLE D'AJUSTAGE PS 0,5	SHIM RING PS 0,5	PASSSCHEIBE PS 0,5	SPESSORE 0,5MM	
016	80252046	002	RONDELLE PLATE FE/ZNXC3	PLAIN WASHER FE/ZNXC3	SCHEIBE FE/ZNXC3	RONDELLA PIATTA FE/ZNXC3	
017	80281639	022	RONDELLE RESSORT FLZNNC	CONICAL SPRING WASHER FLZNNC	SPANNSCHEIBE FLZNNC	RONDELLA A MOLLA FLZNNC	
018	83019908	002	BAGUE ROULEE A COLLERETTE	FLANGED WRAPPED BUSH	GEROLLTE BUCHSE MIT FLANSCH	ANELLO LUBRIFICATO	
019	83240014	002	CATADIOPTRE	REFLECTOR	RUECKSTRAHLER	CATADIOTTRO	
020	K5606630	002	RONDELLE	WASHER	SCHEIBE	RONDELLA	
021	K7017231	002	TUBE PORTEUR	LIFT TUBE	TRAGROHR	TUBO PORTANTE	
022	K7017261	001	BAGUE	BUSHING	HUELSE	BOCCOLA	
023	K7018830	002	BUTEE	STOP	ANSCHLAG	LIMITATORE	
024	K7018841	001	STRUCTURE	STRUCTURE	STRUKTURTEIL	STRUTTURA	
025	K7021930	001	RESSORT	SPRING	FEDER	MOLLA	

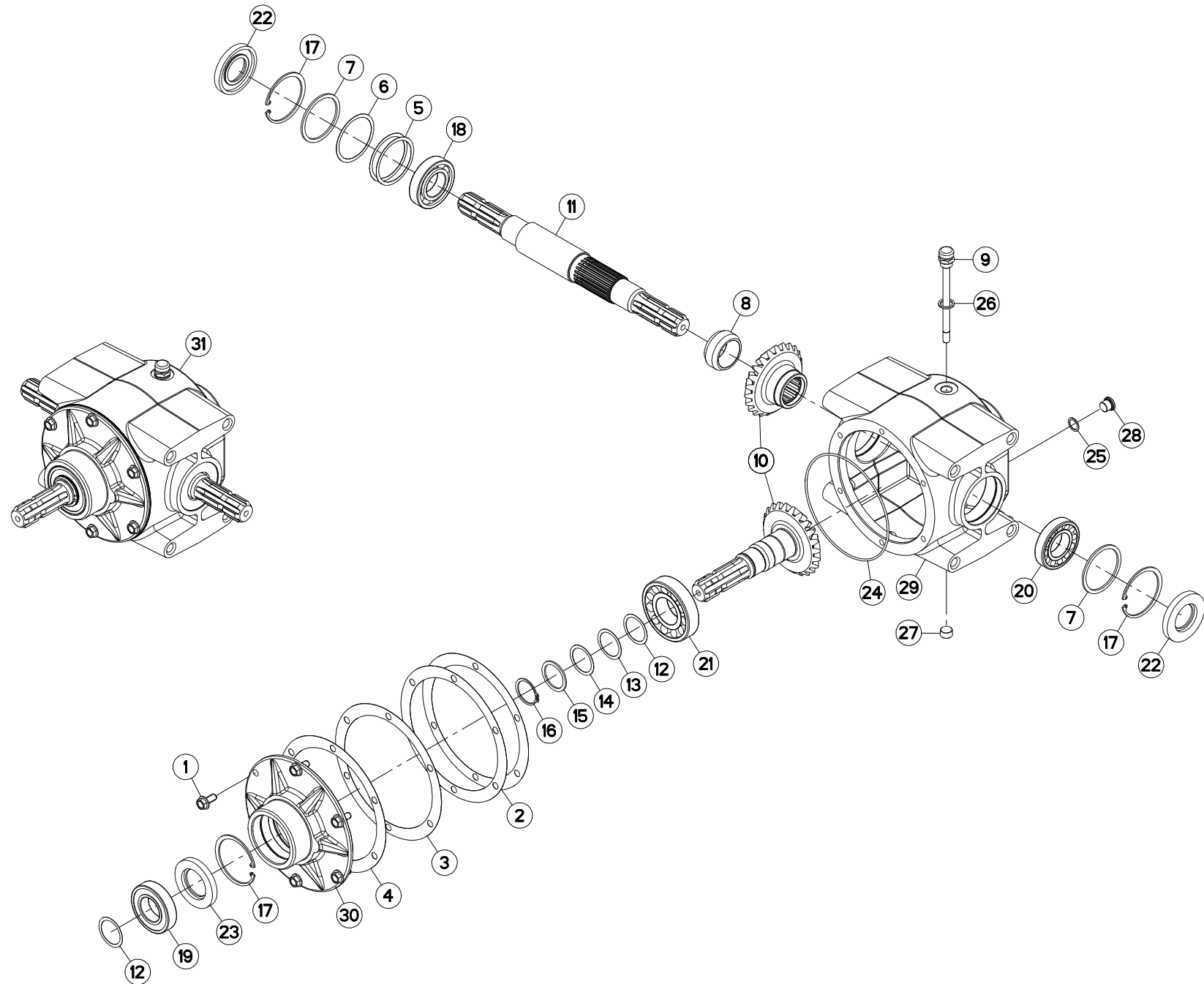



CARTER CENTRAL 1000

CENTRAL GEARBOX 1000

HAUPTGETRIEBE 1000

SCATOLA CENTRALE 1000

Rep	Nr	Qt	Designation	Description	Bezeichnung	Referenza	Remarque - Remark - Bemerkung - Osservazioni
001	50002100	006	VIS AUTOFREINEE	SCREW, SELF-LOCKING	SELBSTSICHERNDE SCHRAUBE	VITE AUTOBLOCCANTE	[1] 5 daN m (37 lbf ft)
002	50018800	002	RONDELLE	WASHER	SCHEIBE	RONDELLA	[1]
003	50018900	001	RONDELLE	WASHER	SCHEIBE	RONDELLA	[1]
004	50019000	001	RONDELLE	WASHER	SCHEIBE	RONDELLA	[1]
005	80257055	002	RONDELLE D'AJUSTAGE PS 0,1	SHIM RING PS 0,1	PASSSCHEIBE PS 0,1	SPESSORE	[1]
006	52239100	001	RONDELLE	WASHER	SCHEIBE	SPESSORE	[1]
007	52505800	002	RONDELLE	WASHER	SCHEIBE	SPESSORE	[1]
008	52545100	001	ENTRETOISE	SPACER	DISTANZHUELSE	DISTANZIALE	[1]
009	55764900	001	RENIFLARD-JAUGE	BREATHER W/ GAUGE	ENTLUEFTUNG/MESSSTAB	ASTINA	[1]
010	56658510	001	COUPLE CONIQUE Z.23/23	GEAR WHEEL AND PINION Z.23/23	KEGELRADPAAR Z.23/23	COPPIA CONICA Z.23/23	[1]
011	56658600	001	ARBRE CANNELE	SPLINED SHAFT	PROFILWELLE	ALBERO CALETTATO	[1]
012	80254040	002	RONDELLE D'AJUSTAGE PS 0,1	SHIM RING PS 0,1	PASSSCHEIBE PS 0,1	SPESSORE	[1]
013	80254041	001	RONDELLE D'AJUSTAGE PS 0,3	SHIM RING PS 0,3	PASSSCHEIBE PS 0,3	SPESSORE	[1]
014	80254042	001	RONDELLE D'AJUSTAGE PS 0,5	SHIM RING PS 0,5	PASSSCHEIBE PS 0,5	RONDELLA	[1]
015	80254043	001	RONDELLE D'APPUI SS 2,5	SUPPORTING RING SS 2,5	STUETZSCHEIBE SS 2,5	RONDELLA D'APPOGGIO	[1]
016	80584000	001	CIRCLIP EXTERIEUR	ELASTIC RING	SICHERUNGSRING	ANELLO	[1]
017	80598000	003	CIRCLIP INTERIEUR	ELASTIC RING	SICHERUNGSRING	ANELLO	[1]
018	81004080	001	ROULEMENT A BILLES	BALL BEARING	KUGELLAGER	CUSCINETTO A SFERE	[1]
019	81004082	001	ROULEMENT A BILLES	BALL BEARING	KUGELLAGER	CUSCINETTO A SFERE	[1]
020	81304079	001	ROULEMENT A ROULEAUX CONIQUES	ROLLER BEARING TAPERED	KEGELROLLENLAGER	CUSCINETTO A RULLO	[1]
021	81304590	001	ROULEMENT A ROULEAUX CONIQUES	TAPERED ROLLER BEARING	KEGELROLLENLAGER	CUSCINETTO A RULLI	[1]
022	82014081	002	BAGUE D'ETANCHEITE	OIL SEAL	RADIALDICHRING	PARAOLIO	[1]
023	82014580	001	BAGUE D'ETANCHEITE	OIL SEAL	RADIALDICHRING	PARAOLIO	
024	82060052	001	JOINT TORIQUE	O-RING	O-RING	GUARNIZIONE	[1]
025	82101622	002	JOINT CUIVRE	SEALING RING	DICHRING	RONDELLA RAME	[1]
026	82131824	001	JOINT CUIVRE	SEALING RING	DICHRING	RONDELLA RAME	[1]
027	82230003	001	BOUCHON FE/ZNXC3	PLUG FE/ZNXC3	VERSCHLUSSSCHRAUBE FE/ZNXC3	TAPPO FE/ZNXC3	[1]
028	82230006	002	BOUCHON FE/ZNXC3	PLUG FE/ZNXC3	VERSCHLUSSSCHRAUBE FE/ZNXC3	TAPPO FE/ZNXC3	[1]
029	K7017031	001	CARTER	HOUSING	GEHAUSE	SCATOLA	
030	K7017041	001	COUVERCLE	LID	DECKEL	COPERCHIO	
031	K7017321	001	CARTER COMPLET	GEARBOX ASSEMBLY	GETRIEBE KPL.	SCATOLA CPL.	+ [1]

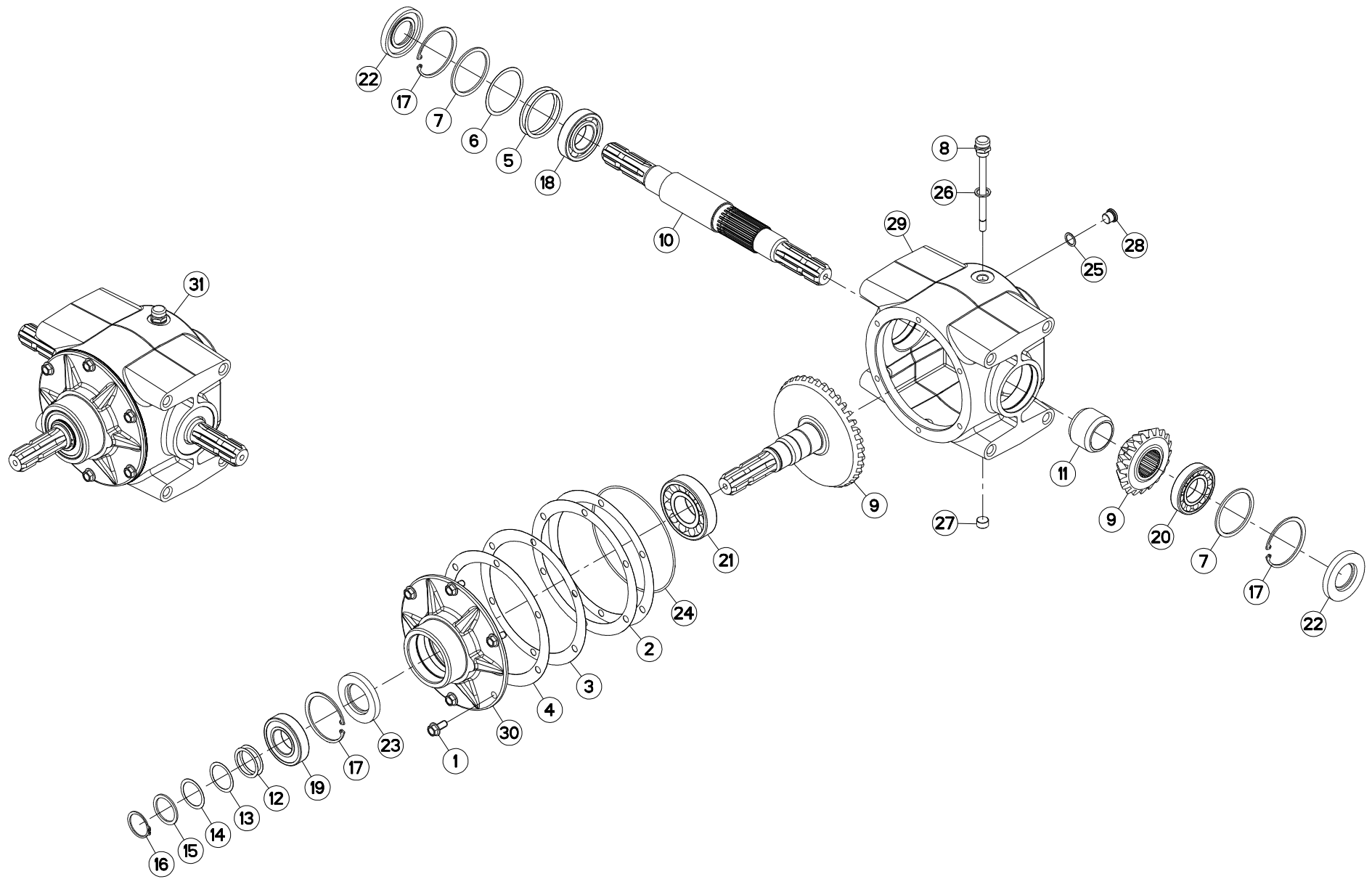



CARTER CENTRAL 540

CENTRAL GEARBOX 540

HAUPTGETRIEBE 540

SCATOLA CENTRALE 540

Rep	Nr	Qt	Designation	Description	Bezeichnung	Referenza	Remarque - Remark - Bemerkung - Osservazioni
001	50002100	006	VIS AUTOFREINEE	SCREW, SELF-LOCKING	SELBSTSICHERNDE SCHRAUBE	VITE AUTOBLOCCANTE	[1] 5 daN m (37 lbf ft)
002	50018800	002	RONDELLE	WASHER	SCHEIBE	RONDELLA	[1]
003	50018900	001	RONDELLE	WASHER	SCHEIBE	RONDELLA	[1]
004	50019000	001	RONDELLE	WASHER	SCHEIBE	RONDELLA	[1]
005	80257055	002	RONDELLE D'AJUSTAGE PS 0,1	SHIM RING PS 0,1	PASSSCHEIBE PS 0,1	SPESSORE	[1]
006	52239100	001	RONDELLE	WASHER	SCHEIBE	SPESSORE	[1]
007	52505800	002	RONDELLE	WASHER	SCHEIBE	SPESSORE	[1]
008	55764900	001	RENIFLARD-JAUGE	BREATHER W/ GAUGE	ENTLUEFTUNG/MESSSTAB	ASTINA	[1]
009	56658410	001	COUPLE CONIQUE 20/37 DENTS	GEAR WHEEL AND PINION Z.20/37	KEGELRADPAAR Z.20/37	COPPIA CONICA Z.20/37	[1]
010	56658600	001	ARBRE CANNELE	SPLINED SHAFT	PROFILWELLE	ALBERO CALETTATO	[1]
011	56658700	001	ENTRETOISE	SPACER	DISTANZHUELSE	DISTANZIALE	[1]
012	80254040	002	RONDELLE D'AJUSTAGE PS 0,1	SHIM RING PS 0,1	PASSSCHEIBE PS 0,1	SPESSORE	[1]
013	80254041	001	RONDELLE D'AJUSTAGE PS 0,3	SHIM RING PS 0,3	PASSSCHEIBE PS 0,3	SPESSORE	[1]
014	80254042	001	RONDELLE D'AJUSTAGE PS 0,5	SHIM RING PS 0,5	PASSSCHEIBE PS 0,5	RONDELLA	[1]
015	80254043	001	RONDELLE D'APPUI SS 2,5	SUPPORTING RING SS 2,5	STUETZSCHEIBE SS 2,5	RONDELLA D'APPOGGIO	[1]
016	80584000	001	CIRCLIP EXTERIEUR	ELASTIC RING	SICHERUNGSRING	ANELLO	[1]
017	80598000	003	CIRCLIP INTERIEUR	ELASTIC RING	SICHERUNGSRING	ANELLO	[1]
018	81004080	001	ROULEMENT A BILLES	BALL BEARING	KUGELLAGER	CUSCINETTO A SFERE	[1]
019	81004082	001	ROULEMENT A BILLES	BALL BEARING	KUGELLAGER	CUSCINETTO A SFERE	[1]
020	81304079	001	ROULEMENT A ROULEAUX CONIQUES	ROLLER BEARING TAPERED	KEGELROLLENLAGER	CUSCINETTO A RULLO	[1]
021	81304590	001	ROULEMENT A ROULEAUX CONIQUES	TAPERED ROLLER BEARING	KEGELROLLENLAGER	CUSCINETTO A RULLI	[1]
022	82014081	002	BAGUE D'ETANCHEITE	OIL SEAL	RADIALDICHRING	PARAOLIO	[1]
023	82014580	001	BAGUE D'ETANCHEITE	OIL SEAL	RADIALDICHRING	PARAOLIO	[1]
024	82060052	001	JOINT TORIQUE	O-RING	O-RING	GUARNIZIONE	[1]
025	82101622	002	JOINT CUIVRE	SEALING RING	DICHRING	RONDELLA RAME	[1]
026	82131824	001	JOINT CUIVRE	SEALING RING	DICHRING	RONDELLA RAME	[1]
027	82230003	001	BOUCHON FE/ZNXC3	PLUG FE/ZNXC3	VERSCHLUSSSCHRAUBE FE/ZNXC3	TAPPO FE/ZNXC3	[1]
028	82230006	002	BOUCHON FE/ZNXC3	PLUG FE/ZNXC3	VERSCHLUSSSCHRAUBE FE/ZNXC3	TAPPO FE/ZNXC3	[1]
029	K7017031	001	CARTER	HOUSING	GEHAUSE	SCATOLA	[1]
030	K7017041	001	COUVERCLE	LID	DECKEL	COPERCHIO	[1]
031	K7017331	001	CARTER COMPLET	GEARBOX ASSEMBLY	GETRIEBE KPL.	SCATOLA CPL.	[1]

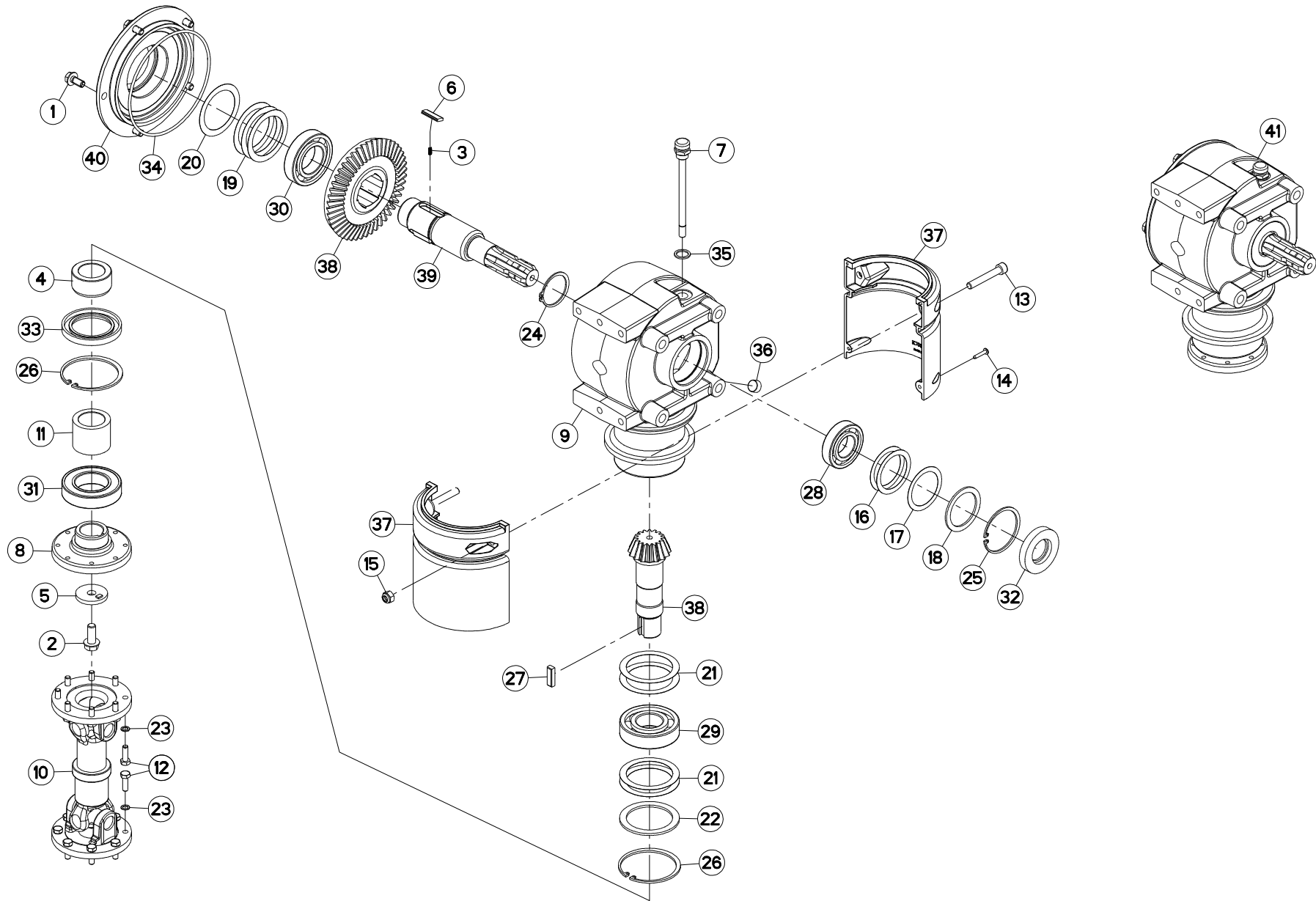



GMD2820F 1000
GMD2820F 540

B 0001 > C 0000
B 0001 > C 0000

K70R0564 B

CARTER LATERAL

SIDE GEARBOX

SEITENGETRIEBE

RIDUTTORE LATERALE

Rep	Nr	Qt	Designation	Description	Bezeichnung	Referenza	Remarque - Remark - Bemerkung - Osservazioni
001	50002100	005	VIS AUTOFREINEE	SCREW, SELF-LOCKING	SELBSTSICHERNDE SCHRAUBE	VITE AUTOBLOCCANTE	[1] 5 daN m (37 lbf ft)
002	50006200	001	VIS	SCREW	SCHRAUBE	VITE	[1]
003	55745700	003	RESSORT	SPRING	FEDER	MOLLA	[1]
004	56009200	001	ENTRETOISE	SPACER	DISTANZHUELSE	DISTANZIALE	[1]
005	56145200	001	RONDELLE BUTEE	LOCK WASHER	SICHERUNGSSCHEIBE	RONDELLA	[1]
006	56548700	003	CLIQUET	RATCHET	SPERRKLINKE	NOTTOLINO	[1]
007	55764900	001	RENIFLARD-JAUGE	BREATHER W/ GAUGE	ENTLUEFTUNG/MESSSTAB	ASTINA	[1]
008	56630200	001	FLASQUE	FLANGE	FLANSCH	FLANGIA	[1]
009	56655030	001	CARTER	HOUSING	GEHAEUSE	SCATOLA	[1]
010	56806510	001	TRANSMISSION	PTO SHAFT	GELENKWELLE	CARDANO	[1]
011	56856700	001	ENTRETOISE	SPACER	DISTANZHUELSE	DISTANZIALE	[1]
012	80060826	016	VIS TETE HEXAGONALE FE/ZNXC3	HEAD HEX SCREW FE/ZNXC3	SECHSKANTSCHRAUBE FE/ZNXC3	VITE TESTA ESAGONALE FE/ZNXC3	2,5 daN m (18 lbf ft)
013	80081065	002	VIS TETE CYL.SIX P.CR.FE/ZNXC3	SCREW, SOCKET HEAD FE/ZNXC3	ZYLINDERSCHR.INNENSEC.FE/ZNXC3	VITE A TESTA CILINDR. FE/ZNXC3	
014	80190425	002	VIS A TOLE T/CYL.BOMB.INOX	PEN HEAD TAPPING SCREW INOX	LINSEN-BLECHSCHRAUBE INOX	VITE INOX	
015	80201030	002	ECROU HEX.AUTOFREINE FE/ZNXC3	SELF-LOCKING NUT FE/ZNXC3	SELBSTSICH.MUTTER FE/ZNXC3	DADO AUTOBLOCCANTE FE/ZNXC3	
016	80255670	002	RONDELLE D'AJUSTAGE PS 0,1	SHIM RING PS 0,1	PASSSCHEIBE PS 0,1	SPESSORE	[1] Q?
017	80255671	001	RONDELLE D'AJUSTAGE PS 0,3	SHIM RING PS 0,3	PASSSCHEIBE PS 0,3	SPESSORE PS 0,3	[1]
018	80255677	001	RONDELLE D'AJUSTAGE SS 3,0	SUPPORTING RING SS 3,0	STUETZSCHEIBE SS 3,0	SPESSORE	[1]
019	80256565	003	RONDELLE D'AJUSTAGE PS 0,1	SHIM RING PS 0,1	PASSSCHEIBE PS 0,1	SPESSORE	[1] Q?
020	80256566	001	RONDELLE D'AJUSTAGE PS 0,2	SHIM RING PS 0,2	PASSSCHEIBE PS 0,2	SPESSORE	[1]
021	80257070	004	RONDELLE D'AJUSTAGE PS 0,1	SHIM RING PS 0,1	PASSSCHEIBE PS 0,1	SPESSORE	[1] Q?
022	80257078	001	RONDELLE D'APPUI SS 3,5	SUPPORTING RING SS 3,5	STUETZSCHEIBE SS 3,5	RONDELLA D'APPOGGIO	[1]
023	80280820	016	RONDELLE RESSORT CRANTEE	CONICAL SPRING WASHER	SPANNSCHEIBE	RONDELLA MOLLA	
024	80585200	001	CIRCLIP EXTERIEUR	RETAINING RING	SICHERUNGSRING	ANELLO	[1]
025	80597200	001	CIRCLIP INTERIEUR	RETAINING RING	SICHERUNGSRING	ANELLO	[1]
026	80599000	002	CIRCLIP INTERIEUR	ELASTIC RING	SICHERUNGSRING	ANELLO	[1]
027	80651031	001	CLAVETTE PARALLELE	KEY, PARALLEL	PASSFEDER	CHIAVETTA	[1]
028	81003572	001	ROULEMENT A BILLES	BALL BEARING	KUGELLAGER	CUSCINETTO A SFERE	[1]
029	81004090	001	ROULEMENT A BILLES	BALL BEARING	KUGELLAGER	CUSCINETTO A SFERE	[1]
030	81004585	001	ROULEMENT A BILLES	BALL BEARING	KUGELLAGER	CUSCINETTO A SFERE	[1]
031	81005091	001	ROULEMENT A BILLES	BALL BEARING	KUGELLAGER	CUSCINETTO A SFERE	[1]
032	82013572	001	BAGUE D'ETANCHEITE	OIL SEAL	RADIALDICHRING	PARAOLIO	[1]
033	82016090	001	BAGUE D'ETANCHEITE	OIL SEAL	RADIALDICHRING	PARAOLIO	[1]
034	82060050	001	JOINT TORIQUE	O-RING	O-RING	GUARNIZIONE	[1]
035	82131824	001	JOINT CUIVRE	SEALING RING	DICHRING	RONDELLA RAME	[1]
036	82230003	001	BOUCHON FE/ZNXC3	PLUG FE/ZNXC3	VERSCHLUSSSCHRAUBE FE/ZNXC3	TAPPO FE/ZNXC3	[1]
037	K7003170	002	COQUILLE DE PROTECTION	COVER	SCHALE	LAMIERA	
038	K7006731	001	COUPLE CONIQUE 16/47 DENTS	GEAR WHEEL AND PINION Z.16/47	KEGELRADPAAR Z.16/47	COPPIA CONICA 16/47D	[1]
039	K7018540	001	ARBRE	SHAFT	WELLE	ALBERO	[1]
040	K7018550	001	FLASQUE	FLANGE	FLANSCH	FLANGIA	[1]
041	K7018561	001	CARTER	HOUSING	GEHAEUSE	SCATOLA	[1] +[1]

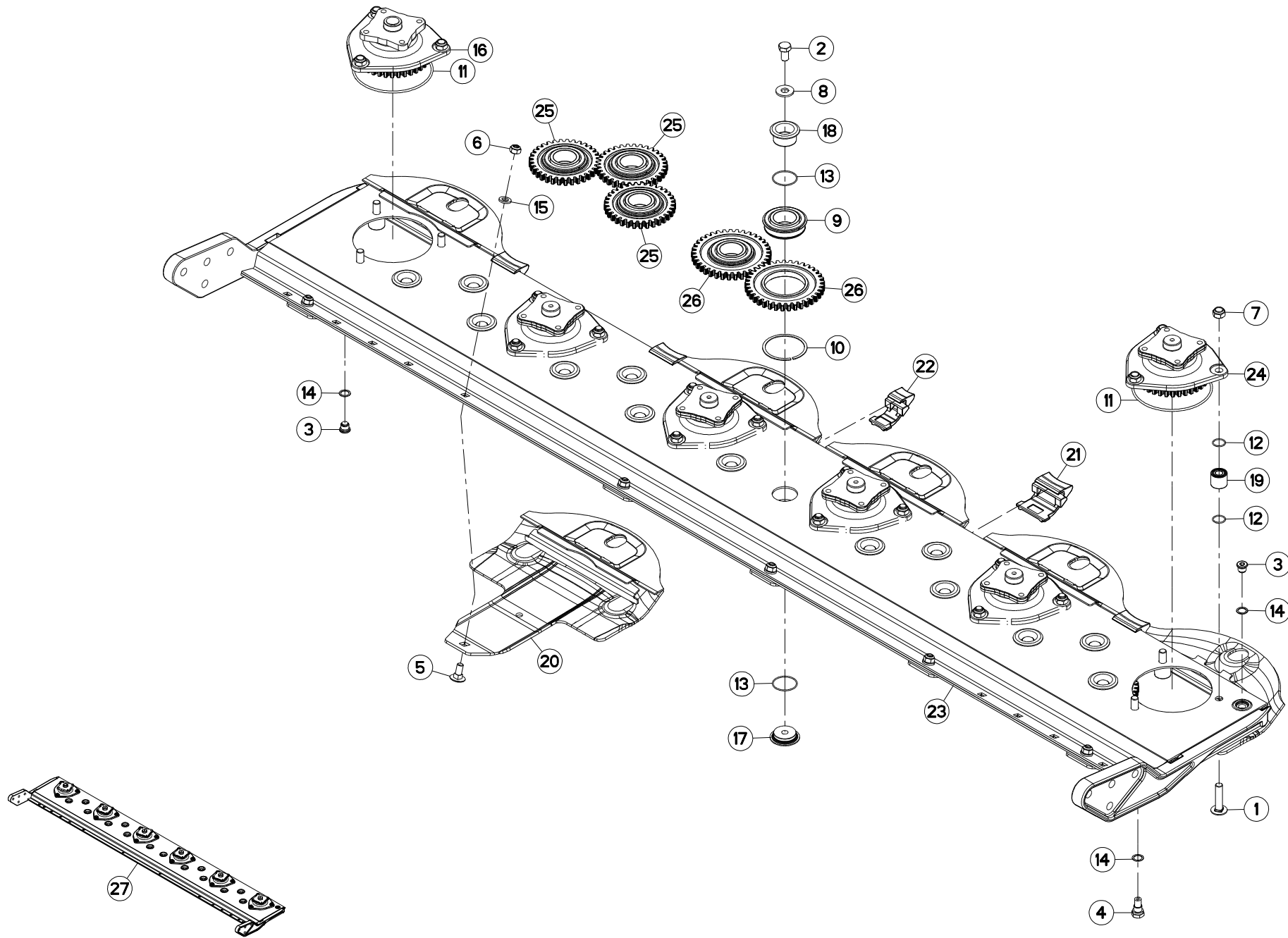



GMD2820F 1000
GMD2820F 540

B 0001 > C 0000
B 0001 > C 0000

K70R0577 D

CARTER DU PORTE - DISQUES

CUTTERBAR GEAR CASE

MÄHBALKEN

SCATOLA INGRAN. BARRA COLTELI

Rep	Nr	Qt	Designation	Description	Bezeichnung	Referenza	Remarque - Remark - Bemerkung - Osservazioni
001	50073910	018	VIS TBCC COURT	BOLT, CARRIAGE, SHORT NECK	FLACHRUNDSCHR.4KT ANSATZ	BULLONE	[1]
002	50074000	014	VIS AVEC REVÊTEMENT ADHESIF	SCREW WITH ADHESIVE COATING	KLEBE BESCHICHTETE SCHRAUBE	VITE CON RIVETTAMENTO ADESIVO	[1] 21,5 daN m (157 lbf ft)
003	56207000	002	BOUCHON MAGNETIQUE	PLUG, MAGNETIC	MAGNET-VERSCHLUSSSCHRAUBE	TAPPO CALAMITATO	[1]
004	56212300	001	BOUCHON TROP PLEIN/AERATION	OVERFLOW VALVE	ENTLUEFTUNGS-/UEBERLAUFSTOPFEN	TAPPO	[1]
005	80031230	006	VIS J FE/ZNXC3	CUP SQUARE BOLT FE/ZNXC3	FLACHRUNDSCHRAUBE FE/ZNXC3	VITE FE/ZNXC3	[1]
006	80201248	006	ECROU HEX.BAS AUTOFR.FLZNNC	SELF-LOCKING NUT FLZNNC	SELBSTSICHERND.MUTTER FLZNNC	DADO AUTOBLOCCANTE FLZNNC	[1]
007	80201448	018	ECROU HEX.BAS AUTOFR.FLZNNC	SELF-LOCKING NUT FLZNNC	SELBSTSICHERND.MUTTER FLZNNC	DADO AUTOBLOCCANTE FLZNNC	[1]
008	80281414	014	RONDELLE RESSORT FLZNNC	CONICAL SPRING WASHER FLZNNC	SPANNSCHEIBE FLZNNC	RONDELLA MOLLA FLZNNC	[1]
009	81104580	014	ROULEMENT A BILLES SPECIAL	BEARING	KUGELLAGER	CUSCINETTO SPECIALE	[1]
010	81104581	014	SEGMENT D'ARRET SPECIAL	SNAP RING	SPRENGRING	SEGMENTO	[1]
011	82060046	006	JOINT TORIQUE	O-RING	O-RING	GUARNIZIONE	
012	82062226	036	JOINT TORIQUE	O-RING	O-RING	GUARNIZIONE	[1]
013	82064550	028	JOINT TORIQUE	O-RING	O-RING	GUARNIZIONE	[1]
014	82101622	003	JOINT CUIVRE	SEALING RING	DICHTRING	RONDELLA RAME	[1]
015	80281254	006	RONDELLE CONIQUE BLOC.FLZNNC	CONICAL SPRING WASHER FLZNNC	SPANNSCHEIBE FLZNNC	RONDELLA CONICA FLZNNC	
016	K6000030	001	BOITIER D'ENTREE	DRIVE HOUSING	GEHAEUSE	SCATOLA	[1] +[2]
017	K6800071	014	AXE	PIN	ACHSE	ASSE	[1]
018	K6800080	014	AXE	PIN	ACHSE	ASSE	[1]
019	K6800090	018	ENTRETOISE	SPACER	DISTANZHUELSE	DISTANZIALE	[1]
020	K6800123	006	PATIN	SKID	GLEITKUFE	PATTINO	
021	K6800671	004	PLAQUE	PLATE	PLATTE	PIASTRA	
022	K6800681	001	PLAQUE	PLATE	PLATTE	PIASTRA	
023	K6800780	001	BARRE	BAR	BALKEN	BARRA	[1]
024	K6800851	005	BOITIER	HOUSING	GEHAEUSE	SCATOLA	[1] +[2]
025	K6801020	012	ROUE DENTEE	GEAR	STIRNRAD	PINIONE	[1]
026	K6801030	002	ROUE DENTEE	GEAR	STIRNRAD	PINIONE	[1]
027	K7020050	001	PD RECH.GMD2820	REPLACEMENT CUTTERBAR GMD2820	ERSATZBALKEN GMD2820	BARRA GMD2820	+ [1]

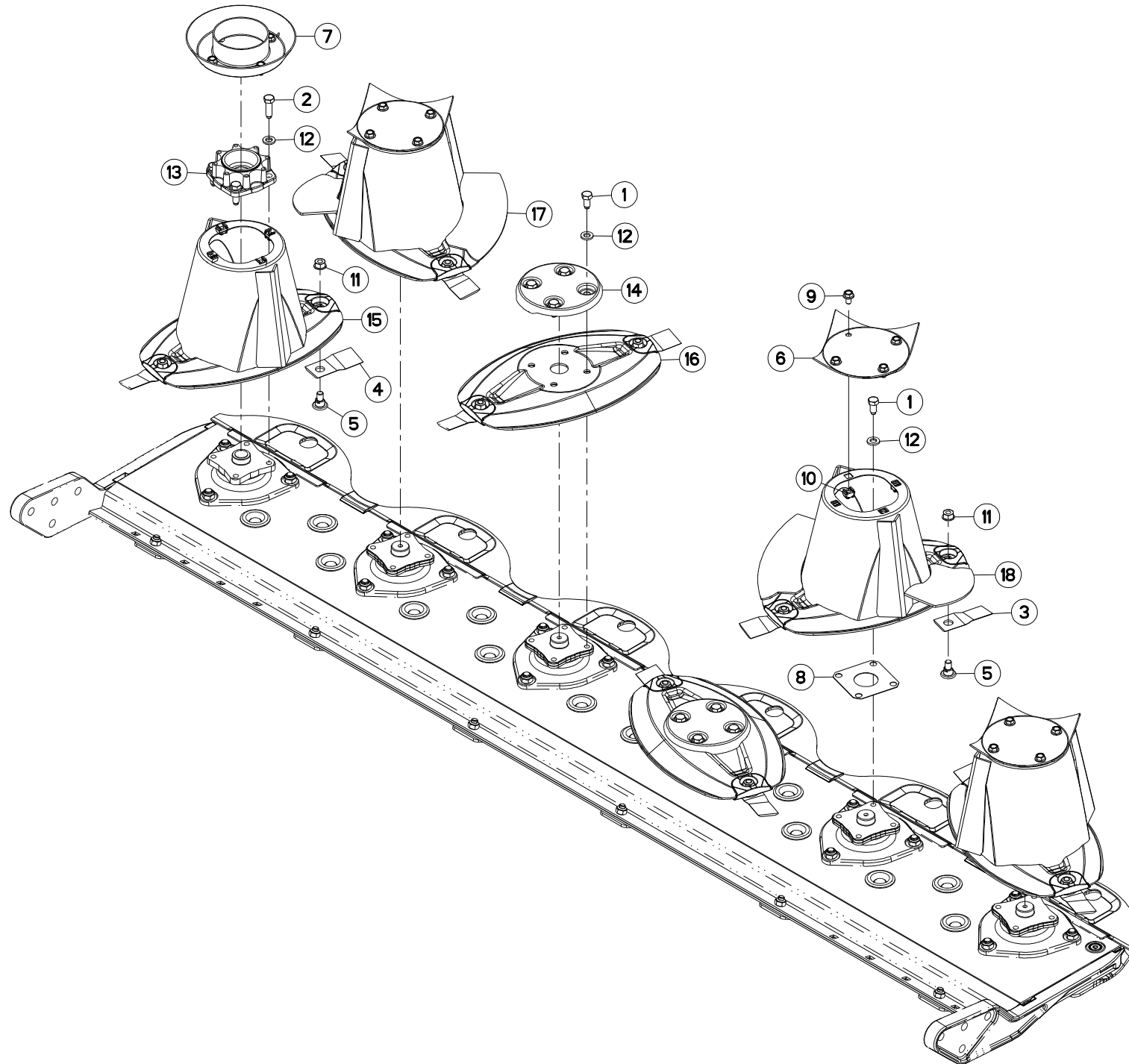



GMD2820F 1000
GMD2820F 540

B 0001 > C 0000
B 0001 > C 0000

K70R0719 C

DISQUES

DISCS

SCHEIBEN

DISCHI

Rep	Nr	Qt	Designation	Description	Bezeichnung	Referenza	Remarque - Remark - Bemerkung - Osservazioni
001	50068500	020	VIS	SCREW	SCHRAUBE	VITE	
002	50086900	004	VIS	SCREW	SCHRAUBE	VITE	
003	55903210	006	COUTEAU VRILLE T.A.G ISO5718	ANGLED BLADE LEFT TURN.ISO5718	GEKROEP.MESS.LINKSDREH.ISO5718	COLTEL.PIEGATO STD-SX ISO5718	
004	55903310	006	COUTEAU VRILLE T.A.D ISO5718	ANGLED BLAD.RIGHT TURN.ISO5718	GEKROEP.MESS.RECHTSDRE.ISO5718	COLTEL.PIEGATO STD-DX ISO5718	
005	56115800	012	VIS AUTOFREINEE	SCREW, SELF-LOCKING	SELBSTSICHERNDE SCHRAUBE	VITE AUTOBLOCCANTE	
006	56803420	003	VIROLE DU CONE EXTERIEUR	DISC COVER	SCHEIBENDECKEL	PIASTRA	
007	56806610	001	VIROLE	DISC COVER	SCHEIBENDECKEL	COPERCHIO DEL CONO	
008	56807100	006	ENTRETOISE	SPACER	DISTANZSCHEIBE	DISTANZIALE	
009	80131017	016	VIS AUTOBLOQUANTE FLZNNC	UNDERSERR.S-LOC.SCREW FLZNNC	SPERRZAHN-BUNDSCHRAU.FLZNNC	VITE FLZNNC	
010	80201055	016	ECROU CAGE	CAGE NUT	KAEFIG MUTTER	DADO IN GABBIA	
011	80201262	012	ECROU TWOLOK FLZNNC	SELF-LOCKING NUT FLZNNC	SELBSTSICHERNDE MUTTER FLZNNC	DADO TWOLOCK FLZNNC	
012	80281254	024	RONDELLE CONIQUE BLOC.FLZNNC	CONICAL SPRING WASHER FLZNNC	SPANNSCHEIBE FLZNNC	RONDELLA CONICA FLZNNC	
013	K6000090	001	ENTRETOISE	SPACER	DISTANZHUELSE	DISTANZIALE	
014	K6800710	002	CACHE	COVER	SCHUTZ	PROTEZIONE	
015	K6800952	002	DISQUE CONE HAUT CPLT	OUTER DISC CPLT	AUSSENSCHEIBE KOMPL.	DISCO CONO ALTO	
016	K6800962	002	DISQUE PLAT CPLT	DISC FLAT,CPLT	MAEHSCHIBE FLACH, KOMPL.	DISCO PIATTO	
017	K6804290	001	DISQUE CONE SPIRALE T.A.D PR	DISC WITH SPI.RIGHT HD TURN SP	SCHEIBE MIT SPI.RECHTSDREH.ET	DISCO CON SPIRALE TAD	
018	K6804300	001	DISQUE CONE SPIRALE T.A.G PR	DISC WITH SPI.LEFT HD TURN SP	SCHEIBE MIT SPI.LINKSDREH. ET	DISCO CON SPIRALE TAG	

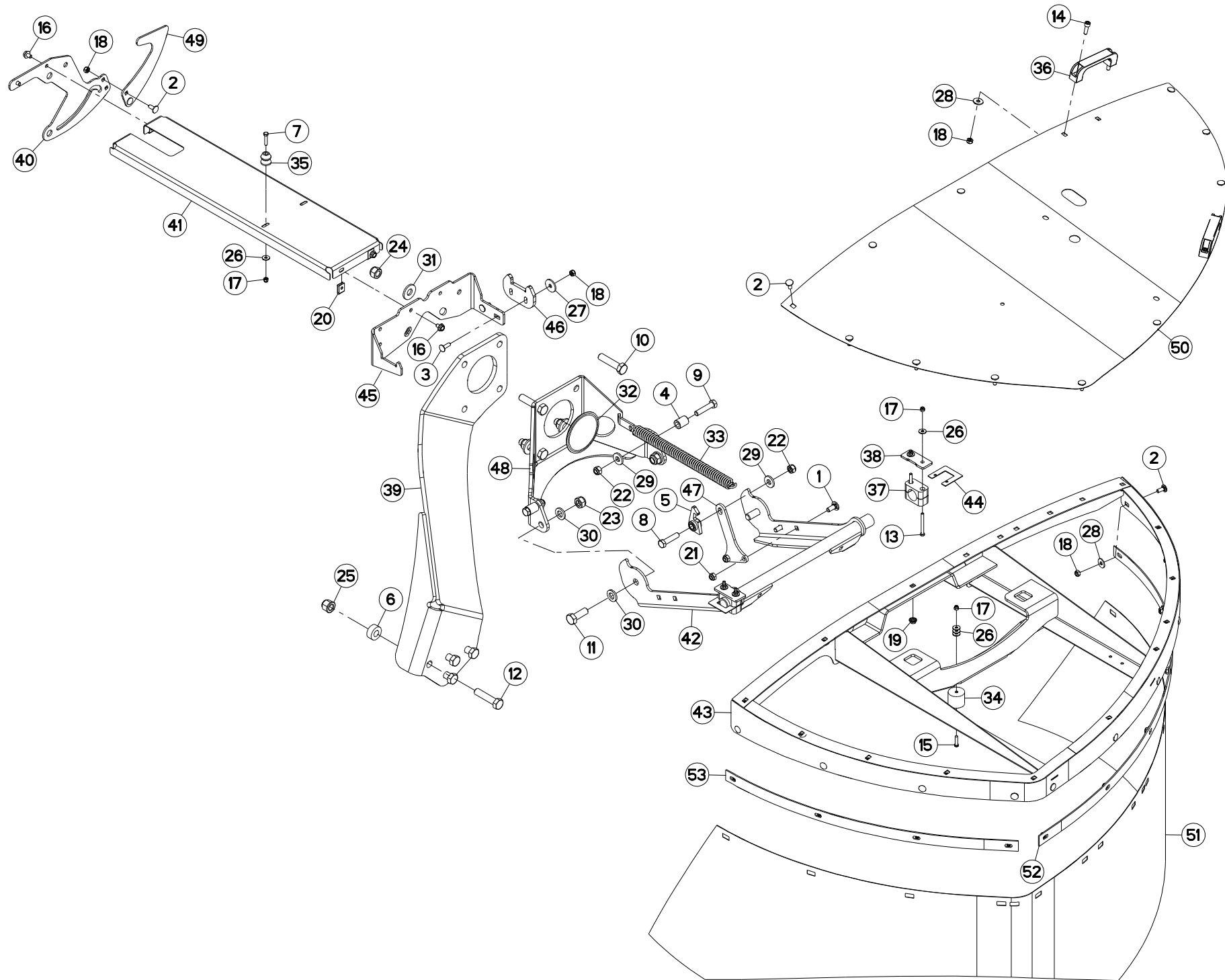



GMD2820F 1000
GMD2820F 540

B 0001 > C 0000
B 0001 > C 0000

K70R0585 D

PROTECTEURS (DROITE)

SAFETY GUARDS (RIGHT)

SCHUTZVORRICHTUNGEN (RECHTS)

PARAPETTI (DX)

Rep	Nr	Qt	Designation	Description	Bezeichnung	Referenza	Remarque - Remark - Bemerkung - Osservazioni
001	50002200	002	VIS TBCC COURT	BOLT, CARRIAGE, SHORT NECK	FLACHRUNDSCHR.4KT ANSATZ	BULLONE	
002	50070300	023	VIS TBCC COURT	BOLT, CARRIAGE, SHORT NECK	FLACHRUNDSCHR.4KT ANSATZ	BULLONE	
003	50072200	002	VIS TBCC COURT	BOLT, CARRIAGE, SHORT NECK	FLACHRUNDSCHR.4KT ANSATZ	BULLONE	
004	55734700	002	TUBE	TUBE	ROHR	TUBO	
005	55749800	001	VERROU	LATCH	RIEGEL	LEVA	
006	56202300	004	DOUILLE	WASHER	DISTANZSCHEIBE	RONDELLA	
007	80060630	001	VIS TETE HEXAGONALE FE/ZNXC3	HEX BOLT FE/ZNXC3	SECHSKANTSCHRAUBE FE/ZNXC3	VITE TESTA ESAGONALE FE/ZNXC3	
008	80061249	001	VIS TETE HEXAGONALE FE/ZNXC3	HEXAGON HEAD SCREW FE/ZNXC3	SECHSKANTSCHRAUBE FE/ZNXC3	VITE TESTA ESAGONALE FE/ZNXC3	
009	80061296	002	VIS TETE HEXAGONALE FE/ZNXC3	HEXAGON HEAD SCREW FE/ZNXC3	SECHSKANTSCHRAUBE FE/ZNXC3	VITE TESTA ESAGONALE FE/ZNXC3	
010	80061637	004	VIS TETE HEXAGONALE FLZNNC	HEXAGON HEAD SCREW FLZNNC	SECHSKANTSCHRAUBE FLZNNC	VITE TESTA ESAGONALE FLZNNC	31 daN m (229 lbf ft)
011	80061646	002	VIS TETE HEXAGONALE FE/ZNXC3	HEXAGON HEAD SCREW FE/ZNXC3	SECHSKANTSCHRAUBE FE/ZNXC3	VITE TESTA ESAGONALE FE/ZNXC3	
012	80061683	004	VIS TETE HEXAGONALE	HEXAGON HEAD SCREW	SECHSKANTSCHRAUBE	VITE A TESTA ESAGONALE	39 daN m (228 lbf ft)
013	80080660	004	VIS TETE CYL.SIX P.CR.FE/ZNXC3	ALLEN BOLT M6 X 60	ZYLINDERSCHR.INNENSEC.FE/ZNXC3	VITE A TESTA CILINDR. FE/ZNXC3	
014	80080805	004	VIS TETE CYL.SIX P.CR.FE/ZNXC3	HEX.SOCK.HEAD CAP SCR.FE/ZNXC3	ZYLINDERSCHR.INNENSEC.FE/ZNXC3	VITE A TESTA CILINDR. FE/ZNXC3	
015	80100625	001	VIS TETE CYL.FENDUE INOX	SLOT.CHEES.HEAD SCREW INOX	ZYLINDERSCHAU.SCHLITZ INOX	VITE TESTA CILINDR.INOX	
016	80130812	004	VIS AUTOBLOQUANTE FLZNNC	UNDERSERR.S-LOC.SCREW FLZNNC	SPERRZAHN-BUNDSCHRAU.FLZNNC	VITE FLZNNC	
017	80200630	006	ECROU HEX.AUTOFREINE FE/ZNXC3	SELF LOCKING NUT FE/ZNXC3	SELBSTSICHERNDE MUTT.FE/ZNXC3	DADO AUTOBLOCCANTE FE/ZNXC3	
018	80200840	028	ECROU HEX.BAS AUTOFR.FE/ZNXC3	SELF-LOCKING NUT FE/ZNXC3	SELBSTSICHERND.MUTTER FE/ZNXC3	DADO AUTOBLOCCANTE FE/ZNXC3	
019	80200851	001	ECROU AUTOBLOQUANT FE/ZNXC3	UNDERSERRAT.S.LOC.NUT FE/ZNXC3	SPERRZAHN-BUNDMUTTER FE/ZNXC3	DADO FE/ZNXC3	
020	80200855	004	ECROU FE/ZNXC3	CLAMP NUT FE/ZNXC3	MUTTER FE/ZNXC3	PIASTRINA FE/ZNXC3	
021	80201040	002	ECROU HEX.BAS AUTOFR.FE/ZNXC3	SELF LOCKING NUT FE/ZNXC3	SELBSTSICHERND.MUTTER FE/ZNXC3	DADO AUTOBLOCCANTE FE/ZNXC3	
022	80201240	003	ECROU HEX.BAS AUTOFR.FE/ZNXC3	SELF-LOCKING NUT FE/ZNXC3	SELBSTSICHERND.MUTTER FE/ZNXC3	DADO AUTOBLOCCANTE FE/ZNXC3	
023	80201640	002	ECROU HEX.BAS AUTOFR.FE/ZNXC3	SELF-LOCKING NUT FE/ZNXC3	SELBSTSICHERND.MUTTER FE/ZNXC3	DADO AUTOBLOCCANTE FE/ZNXC3	
024	80201647	004	ECROU HEX.AUTOFREINE FE/ZNXC3	SELF-LOCKING NUT FE/ZNXC3	SELBSTSICHERNDE MUTT.FE/ZNXC3	DADO AUTOBLOCCANTE FE/ZNXC3	
025	80201662	004	ECROU HEXAG.EMBASE POLYSTOP	SELF-LOCKING NUT W.COLLAR	SELBSTSICHERNDE BUNDMUTTER	DADO AUTOBLOCCANTE	
026	80250613	008	RONDELLE PLATE FE/ZNXC3	PLAIN WASHER M6 DIN 9021 (D18X	SCHEIBE FE/ZNXC3	RONDELLA PIATTA FE/ZNXC3	
027	80250934	002	RONDELLE PLATE FE/ZNXC3	PLAIN WASHER FE/ZNXC3	SCHEIBE FE/ZNXC3	RONDELLA PIATTA FE/ZNXC3	
028	80250970	024	RONDELLE PLATE FE/ZN	PLAIN WASHER FE/ZN	SCHEIBE FE/ZN	RONDELLA PIATTA FE/ZN	
029	80251331	003	RONDELLE PLATE FE/ZNXC3	PLAIN WASHER FE/ZNXC3	SCHEIBE FE/ZNXC3	RONDELLA PIATTA FE/ZNXC3	
030	80251632	004	RONDELLE PLATE FE/ZNXC3	PLAIN WASHER FE/ZNXC3	SCHEIBE FE/ZNXC3	RONDELLA PIATTA FE/ZNXC3	
031	80281639	004	RONDELLE RESSORT FLZNNC	CONICAL SPRING WASHER FLZNNC	SPANNSCHEIBE FLZNNC	RONDELLA A MOLLA FLZNNC	
032	83040205	001	BOUCHON D'OBTURATION	END PLUG	VERSCHLUSSSTOPFEN	TAPPO DI CHIUSURA	
033	53005900	001	RESSORT	SPRING	FEDER	MOLLA	
034	83090198	001	ATTACHE CAOUTCHOU	LOCKING RUBBER	SCHLIESSGUMMI	ATTACCO DE GOMMA	
035	83090198	001	ATTACHE CAOUTCHOU	LOCKING RUBBER	SCHLIESSGUMMI	ATTACCO DE GOMMA	
036	A7250406	002	POIGNEE	HANDLE	HANDGRIFF	MANIGLIA	
037	A7260032	002	COLLIER SIMPLE D30	CLAMP D30	KLEMMHÄLFTENPAAR D30	COLLARE D.30	
038	K5700940	002	PLAQUETTE	PLATE	PLATTE	PIASTRINA	
039	K7017240	001	JAMBE	LEG	ARM	GAMBA	
040	K7017631	001	PLAQUE	PLATE	PLATTE	PIASTRA	
041	K7017840	001	TOLE	SHEET	BLECH	TELA	
042	K7018201	001	CHARNIERE	HINGE	SCHARNIER	SNODO	
043	K7018992	001	PROTECTEUR	GUARD	SCHUTZ	PROTEZIONE	
044	K7019780	002	CALE	SHIM	DISTANZPLATTE	SPESSORE	
045	K7020221	001	SUPPORT	SUPPORT	TRAEGER	SUPPORTO	
046	K7020230	001	BUTEE	STOP	ANSCHLAG	LIMITATORE	
047	K7020441	001	SUPPORT	SUPPORT	TRAEGER	SUPPORTO	
048	K7020741	001	CHARNIERE	HINGE	SCHARNIER	SNODO	

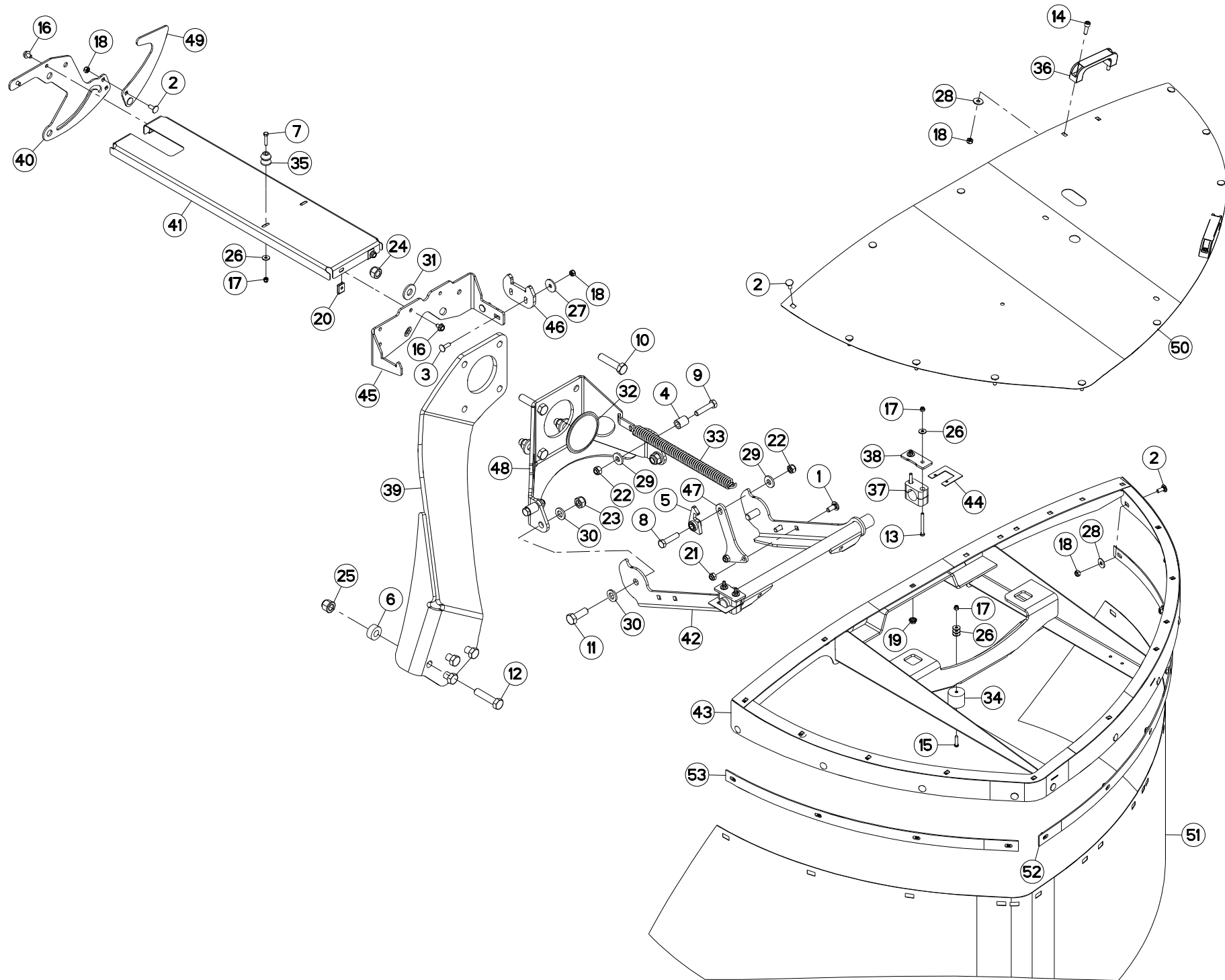



GMD2820F 1000
GMD2820F 540

B 0001 > C 0000
B 0001 > C 0000

K70R0585 D

PROTECTEURS (DROITE)

SAFETY GUARDS (RIGHT)

SCHUTZVORRICHTUNGEN (RECHTS)

PARAPETTI (DX)

Rep	Nr	Qt	Designation	Description	Bezeichnung	Referenza	Remarque - Remark - Bemerkung - Osservazioni
049	K7023260	001	PLAQUE	PLATE	PLATTE	PIASTRA	
050	K7018922	001	TOLE	SHEET	BLECH	TELA	
051	K7018961	001	TOILE DE PROTECTION	CURTAIN, PROTECTIVE	SCHUTZTUCH	TELO DI PROTEZIONE	
052	K7018970	001	PLAT	FLAT	FLACHEISEN	PIATTO	
053	K7018980	001	PLAT	FLAT	FLACHEISEN	PIATTO	

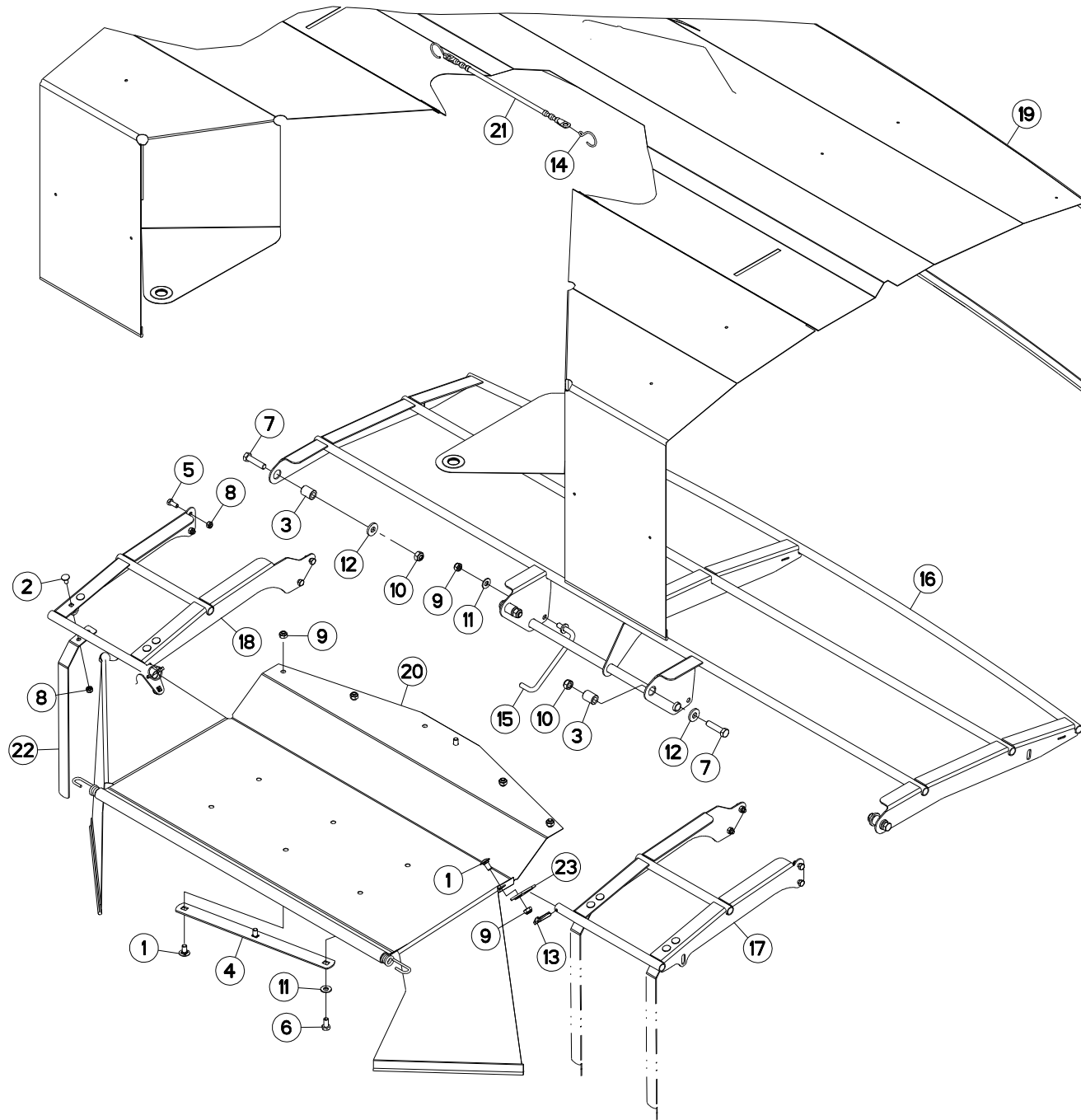



GMD2820F 1000
GMD2820F 540

B 0001 > C 0000
B 0001 > C 0000

K70R0579 C

PROTECTEURS

SAFETY GUARDS

SCHUTZVORRICHTUNGEN

PARAPETTI

Rep	Nr	Qt	Designation	Description	Bezeichnung	Referenza	Remarque - Remark - Bemerkung - Osservazioni
001	50003200	006	VIS TBCC COURT	BOLT, CARRIAGE, SHORT NECK	FLACHRUNDSCHR.4KT ANSATZ	BULLONE	
002	50067100	008	VIS TBCC COURT	BOLT, CARRIAGE, SHORT NECK	FLACHRUNDSCHR.4KT ANSATZ	BULLONE	
003	55734700	004	TUBE	TUBE	ROHR	TUBO	
004	55741300	002	CONTRE-PLAT	BRACKET	BEFESTIGUNGSPLATTE	PIATTO	
005	80060820	008	VIS TETE HEXAGONALE FE/ZNXC3	HEXAGON HEAD SCREW FE/ZNXC3	SECHSKANTSCHRAUBE FE/ZNXC3	VITE TESTA ESAGONALE FE/ZNXC3	
006	80061020	002	VIS TETE HEXAGONALE FE/ZNXC3	HEX. HEAD SCREW FE/ZNXC3	SECHSKANTSCHRAUBE FE/ZNXC3	VITE A TESTA ESAGONALE FE/ZNXC3	
007	80061249	004	VIS TETE HEXAGONALE FE/ZNXC3	HEXAGON HEAD SCREW FE/ZNXC3	SECHSKANTSCHRAUBE FE/ZNXC3	VITE TESTA ESAGONALE FE/ZNXC3	
008	80200840	016	ECROU HEX.BAS AUTOFR.FE/ZNXC3	SELF-LOCKING NUT FE/ZNXC3	SELBSTSICHERND.MUTTER FE/ZNXC3	DADO AUTOBLOCCANTE FE/ZNXC3	
009	80201040	007	ECROU HEX.BAS AUTOFR.FE/ZNXC3	SELF LOCKING NUT FE/ZNXC3	SELBSTSICHERND.MUTTER FE/ZNXC3	DADO AUTOBLOCCANTE FE/ZNXC3	
010	80201248	004	ECROU HEX.BAS AUTOFR.FLZNNC	SELF-LOCKING NUT FLZNNC	SELBSTSICHERND.MUTTER FLZNNC	DADO AUTOBLOCCANTE FLZNNC	
011	80251176	003	RONDELLE PLATE FE/ZNXC3	PLAIN WASHER FE/ZNXC3	SCHEIBE FE/ZNXC3	RONDELLA PIATTA FE/ZNXC3	
012	80251331	004	RONDELLE PLATE FE/ZNXC3	PLAIN WASHER FE/ZNXC3	SCHEIBE FE/ZNXC3	RONDELLA PIATTA FE/ZNXC3	
013	80560440	002	GOUPILLE AUTOMATIQUE FE/ZNXC3	LINCH PIN FE/ZNXC3	KLAPPSTECKER FE/ZNXC3	COPPIGLIA FE/ZNXC3	
014	83070061	002	ESSE SERIE INEGALE FE/ZNXC3	HOOK FE/ZNXC3	HAKEN FE/ZNXC3		
015	K7008290	001	TRINGLE	LINK	STREBE	TRIANGOLO	
016	K7017751	001	RAMBARDE	HAND RAIL	SCHUTZ	PROTEZIONE	
017	K7017781	001	RAMBARDE	HAND RAIL	SCHUTZ	PROTEZIONE	
018	K7017791	001	RAMBARDE	HAND RAIL	SCHUTZ	PROTEZIONE	
019	K7017872	001	TOILE DE PROTECTION	CURTAIN, PROTECTIVE	SCHUTZTUCH	TELO DI PROTEZIONE	
020	K7017882	001	TOILE DE PROTECTION	CURTAIN, PROTECTIVE	SCHUTZTUCH	TELO DI PROTEZIONE	
021	K7019000	001	TENDEUR	TENSIONER	SPANNER	TENDITORE	
022	K7021770	004	RESSORT	SPRING	FEDER	MOLLA	
023	K7022100	002	CROCHET	HOOK	HAKEN	GANCIO	

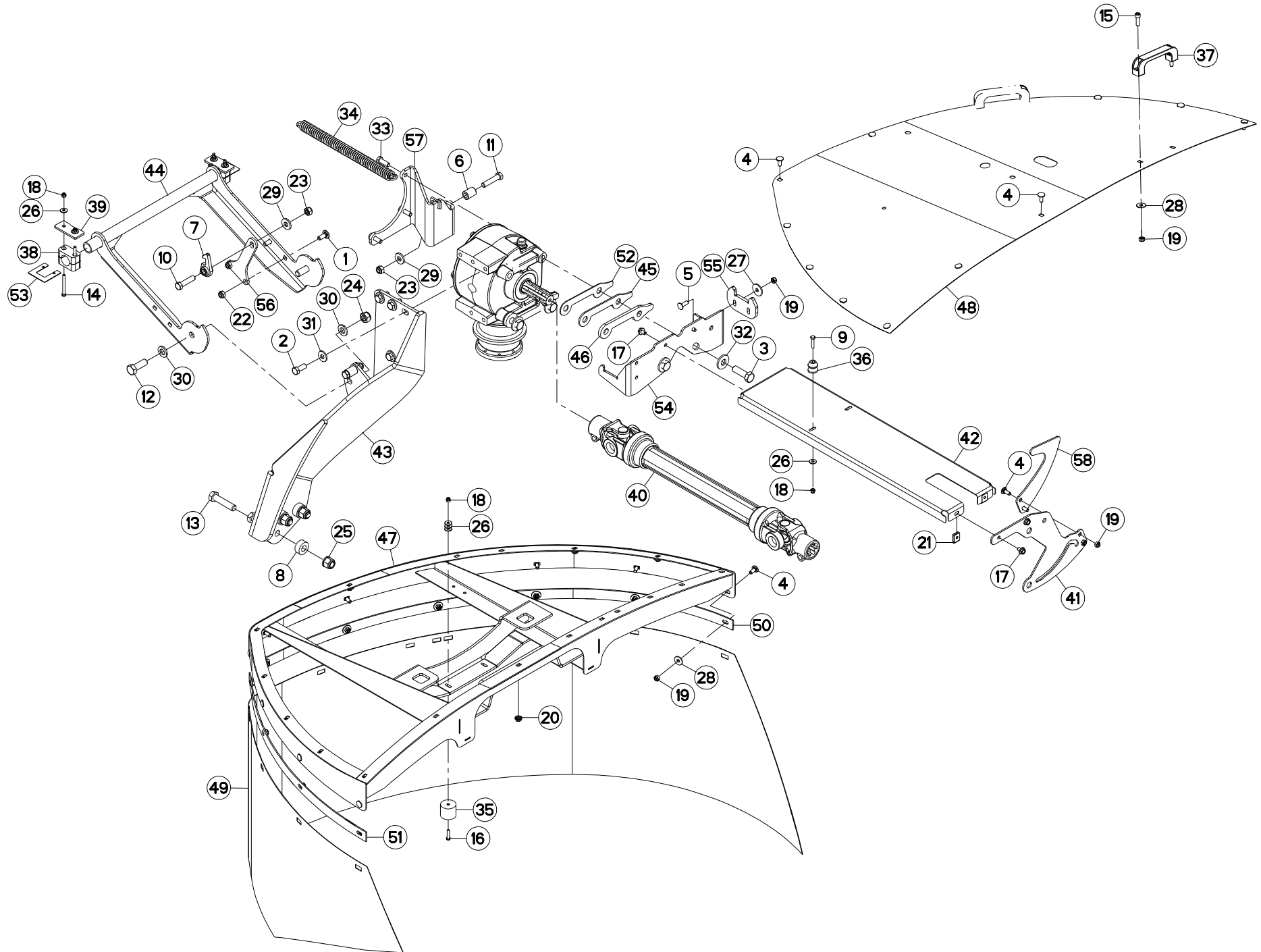



GMD2820F 1000
GMD2820F 540

B 0001 > C 0000
B 0001 > C 0000

K70R0583 D

PROTECTEURS (GAUCHE)

SAFETY GUARDS (LEFT)

SCHUTZVORRICHTUNGEN (LINKS)

PARAPETTI (SX)

Rep	Nr	Qt	Designation	Description	Bezeichnung	Referenza	Remarque - Remark - Bemerkung - Osservazioni
001	50002200	002	VIS TBCC COURT	BOLT, CARRIAGE, SHORT NECK	FLACHRUNDSCHR.4KT ANSATZ	BULLONE	
002	50003600	005	VIS AVEC REVÊTEMENT ADHESIF	SCREW WITH ADHESIVE COATING	KLEBE BESCHICHTETE SCHRAUBE	VITE CON RIVETTAMENTO ADESIVO	14,5 daN m (98 lbf ft)
003	50005700	004	VIS AVEC REVÊTEMENT ADHESIF	SCREW WITH ADHESIVE COATING	KLEBE BESCHICHTETE SCHRAUBE	VITE CON RIVETTAMENTO ADESIVO	31 daN m (229 lbf ft)
004	50070300	023	VIS TBCC COURT	BOLT, CARRIAGE, SHORT NECK	FLACHRUNDSCHR.4KT ANSATZ	BULLONE	
005	50072200	002	VIS TBCC COURT	BOLT, CARRIAGE, SHORT NECK	FLACHRUNDSCHR.4KT ANSATZ	BULLONE	
006	55734700	002	TUBE	TUBE	ROHR	TUBO	
007	55749800	001	VERROU	LATCH	RIEGEL	LEVA	
008	56202300	004	DOUILLE	WASHER	DISTANZSCHEIBE	RONDELLA	
009	80060630	001	VIS TETE HEXAGONALE FE/ZNXC3	HEX BOLT FE/ZNXC3	SECHSKANTSCHRAUBE FE/ZNXC3	VITE TESTA ESAGONALE FE/ZNXC3	
010	80061249	001	VIS TETE HEXAGONALE FE/ZNXC3	HEXAGON HEAD SCREW FE/ZNXC3	SECHSKANTSCHRAUBE FE/ZNXC3	VITE TESTA ESAGONALE FE/ZNXC3	
011	80061296	002	VIS TETE HEXAGONALE FE/ZNXC3	HEXAGON HEAD SCREW FE/ZNXC3	SECHSKANTSCHRAUBE FE/ZNXC3	VITE TESTA ESAGONALE FE/ZNXC3	
012	80061646	002	VIS TETE HEXAGONALE FE/ZNXC3	HEXAGON HEAD SCREW FE/ZNXC3	SECHSKANTSCHRAUBE FE/ZNXC3	VITE TESTA ESAGONALE FE/ZNXC3	
013	80061683	004	VIS TETE HEXAGONALE	HEXAGON HEAD SCREW	SECHSKANTSCHRAUBE	VITE A TESTA ESAGONALE	39 daN m (288 lbf ft)
014	80080660	004	VIS TETE CYL.SIX P.CR.FE/ZNXC3	ALLEN BOLT M6 X 60	ZYLINDERSCHR.INNENSEC.FE/ZNXC3	VITE A TESTA CILINDR. FE/ZNXC3	
015	80080805	004	VIS TETE CYL.SIX P.CR.FE/ZNXC3	HEX.SOCK.HEAD CAP SCR.FE/ZNXC3	ZYLINDERSCHR.INNENSEC.FE/ZNXC3	VITE A TESTA CILINDR. FE/ZNXC3	
016	80100625	001	VIS TETE CYL.FENDUE INOX	SLOT.CHEES.HEAD SCREW INOX	ZYLINDERSCHAU.SCHLITZ INOX	VITE TESTA CILINDR.INOX	
017	80130812	004	VIS AUTOBLOQUANTE FLZNNC	UNDERSERR.S.LOC.SCREW FLZNNC	SPERRZAHN-BUNDSCHRAU.FLZNNC	VITE FLZNNC	
018	80200630	006	ECROU HEX.AUTOFREINE FE/ZNXC3	SELF LOCKING NUT FE/ZNXC3	SELBSTSICHERNDE MUTT.FE/ZNXC3	DADO AUTOBLOCCANTE FE/ZNXC3	
019	80200840	028	ECROU HEX.BAS AUTOFR.FE/ZNXC3	SELF-LOCKING NUT FE/ZNXC3	SELBSTSICHERND.MUTTER FE/ZNXC3	DADO AUTOBLOCCANTE FE/ZNXC3	
020	80200851	001	ECROU AUTOBLOQUANT FE/ZNXC3	UNDERSERRAT.S.LOC.NUT FE/ZNXC3	SPERRZAHN-BUNDMUTTER FE/ZNXC3	DADO FE/ZNXC3	
021	80200855	004	ECROU FE/ZNXC3	CLAMP NUT FE/ZNXC3	MUTTER FE/ZNXC3	PIASTRINA FE/ZNXC3	
022	80201040	002	ECROU HEX.BAS AUTOFR.FE/ZNXC3	SELF LOCKING NUT FE/ZNXC3	SELBSTSICHERND.MUTTER FE/ZNXC3	DADO AUTOBLOCCANTE FE/ZNXC3	
023	80201240	003	ECROU HEX.BAS AUTOFR.FE/ZNXC3	SELF-LOCKING NUT FE/ZNXC3	SELBSTSICHERND.MUTTER FE/ZNXC3	DADO AUTOBLOCCANTE FE/ZNXC3	
024	80201640	002	ECROU HEX.BAS AUTOFR.FE/ZNXC3	SELF-LOCKING NUT FE/ZNXC3	SELBSTSICHERND.MUTTER FE/ZNXC3	DADO AUTOBLOCCANTE FE/ZNXC3	
025	80201662	004	ECROU HEXAG.EMBASE POLYSTOP	SELF-LOCKING NUT W.COLLAR	SELBSTSICHERNDE BUNDMUTTER	DADO AUTOBLOCCANTE	
026	80250613	008	RONDELLE PLATE FE/ZNXC3	PLAIN WASHER M6 DIN 9021 (D18X	SCHEIBE FE/ZNXC3	RONDELLA PIATTA FE/ZNXC3	
027	80250934	002	RONDELLE PLATE FE/ZNXC3	PLAIN WASHER FE/ZNXC3	SCHEIBE FE/ZNXC3	RONDELLA PIATTA FE/ZNXC3	
028	80250970	024	RONDELLE PLATE FE/ZN	PLAIN WASHER FE/ZN	SCHEIBE FE/ZN	RONDELLA PIATTA FE/ZN	
029	80251331	003	RONDELLE PLATE FE/ZNXC3	PLAIN WASHER FE/ZNXC3	SCHEIBE FE/ZNXC3	RONDELLA PIATTA FE/ZNXC3	
030	80251632	004	RONDELLE PLATE FE/ZNXC3	PLAIN WASHER FE/ZNXC3	SCHEIBE FE/ZNXC3	RONDELLA PIATTA FE/ZNXC3	
031	80281230	005	RONDELLE RESSORT FLZNNC	CONICAL SPRING WASHER FLZNNC	SPANNSCHEIBE FLZNNC	RONDELLA MOLLA FLZNNC	
032	80281639	004	RONDELLE RESSORT FLZNNC	CONICAL SPRING WASHER FLZNNC	SPANNSCHEIBE FLZNNC	RONDELLA A MOLLA FLZNNC	
033	50006600	003	VIS AVEC REVÊTEMENT ADHESIF	SCREW WITH ADHESIVE COATING	KLEBE BESCHICHTETE SCHRAUBE	VITE CON RIVETTAMENTO ADESIVO	
034	53005900	001	RESSORT	SPRING	FEDER	MOLLA	
035	83090198	001	ATTACHE CAOUTCHOU	LOCKING RUBBER	SCHLIESSGUMMI	ATTACCO DE GOMMA	
036	83090198	001	ATTACHE CAOUTCHOU	LOCKING RUBBER	SCHLIESSGUMMI	ATTACCO DE GOMMA	
037	A7250406	002	POIGNEE	HANDLE	HANDGRIFF	MANIGLIA	
038	A7260032	002	COLLIER SIMPLE D30	CLAMP D30	KLEMMHÄLFTENPAAR D30	COLLARE D.30	
039	K5700940	002	PLAQUETTE	PLATE	PLATTE	PIASTRINA	
040	K7017450	001	TRAN.104 1 3/8-6 560	PTO-S.104 1 3/8-6 560	GELN.104 1 3/8-6 560	CARDA.104 1 3/8-6 560	
041	K7017631	001	PLAQUE	PLATE	PLATTE	PIASTRA	
042	K7017840	001	TOLE	SHEET	BLECH	TELA	
043	K7018171	001	JAMBE	LEG	ARM	GAMBA	
044	K7018201	001	CHARNIERE	HINGE	SCHARNIER	SNODO	
045	K7018490	002	CALE	SHIM	DISTANZPLATTE	SPESSORE	
046	K7018500	002	CALE	SHIM	DISTANZPLATTE	SPESSORE	
047	K7018912	001	PROTECTEUR	GUARD	SCHUTZ	PROTEZIONE	
048	K7018922	001	TOLE	SHEET	BLECH	TELA	

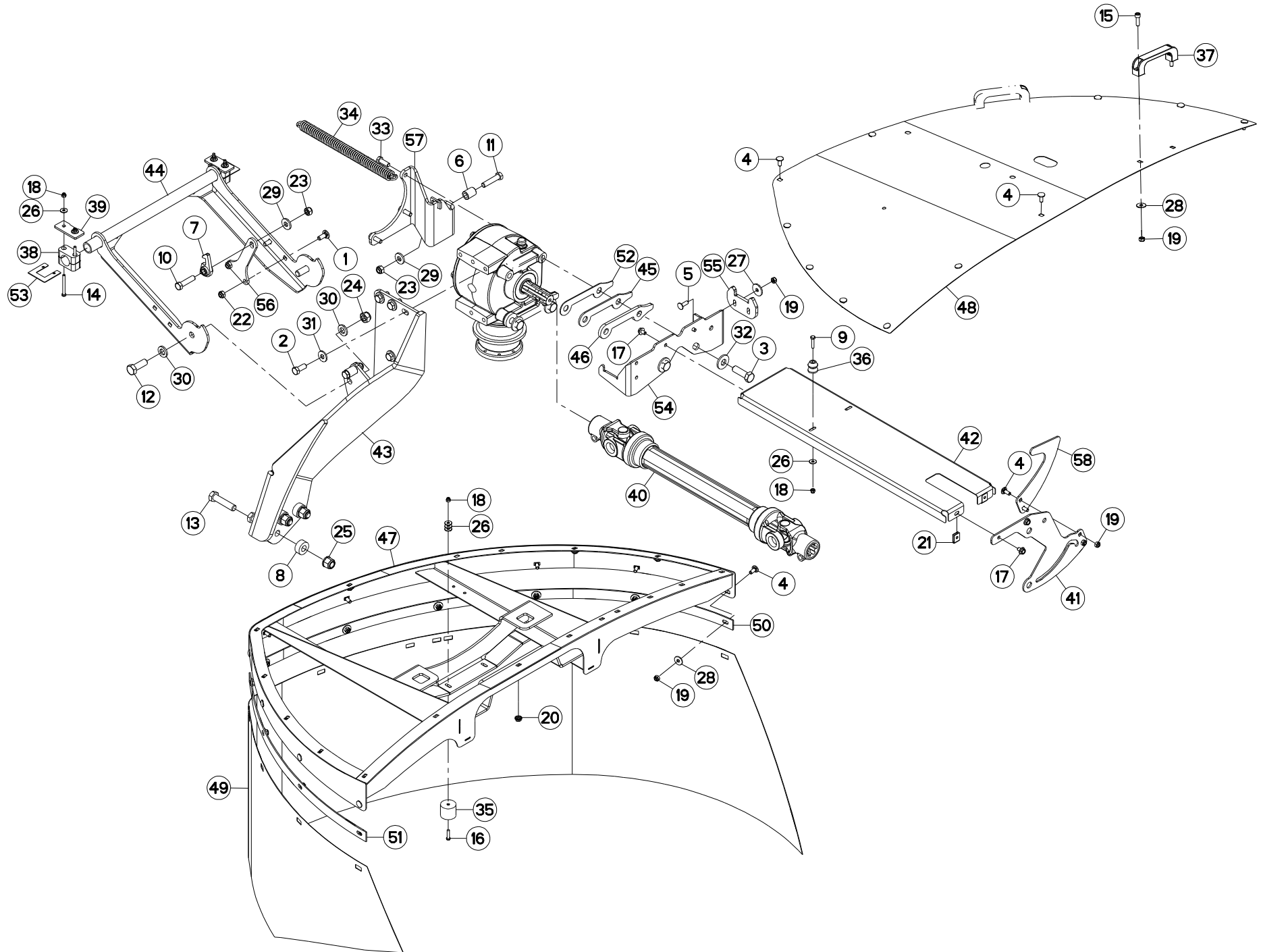



GMD2820F 1000
GMD2820F 540

B 0001 > C 0000
B 0001 > C 0000

K70R0583 D

PROTECTEURS (GAUCHE)

SAFETY GUARDS (LEFT)

SCHUTZVORRICHTUNGEN (LINKS)

PARAPETTI (SX)

Rep	Nr	Qt	Designation	Description	Bezeichnung	Referenza	Remarque - Remark - Bemerkung - Osservazioni
049	K7018961	001	TOILE DE PROTECTION	CURTAIN, PROTECTIVE	SCHUTZTUCH	TELO DI PROTEZIONE	
050	K7018970	001	PLAT	FLAT	FLACHEISEN	PIATTO	
051	K7018980	001	PLAT	FLAT	FLACHEISEN	PIATTO	
052	K7019770	002	CALE	SHIM	DISTANZPLATTE	SPESSORE	
053	K7019780	002	CALE	SHIM	DISTANZPLATTE	SPESSORE	
054	K7020211	001	SUPPORT	SUPPORT	TRAEGER	SUPPORTO	
055	K7020230	001	BUTEE	STOP	ANSCHLAG	LIMITATORE	
056	K7020441	001	SUPPORT	SUPPORT	TRAEGER	SUPPORTO	
057	K7020730	001	CHARNIERE	HINGE	SCHARNIER	SNODO	
058	K7023260	001	PLAQUE	PLATE	PLATTE	PIASTRA	

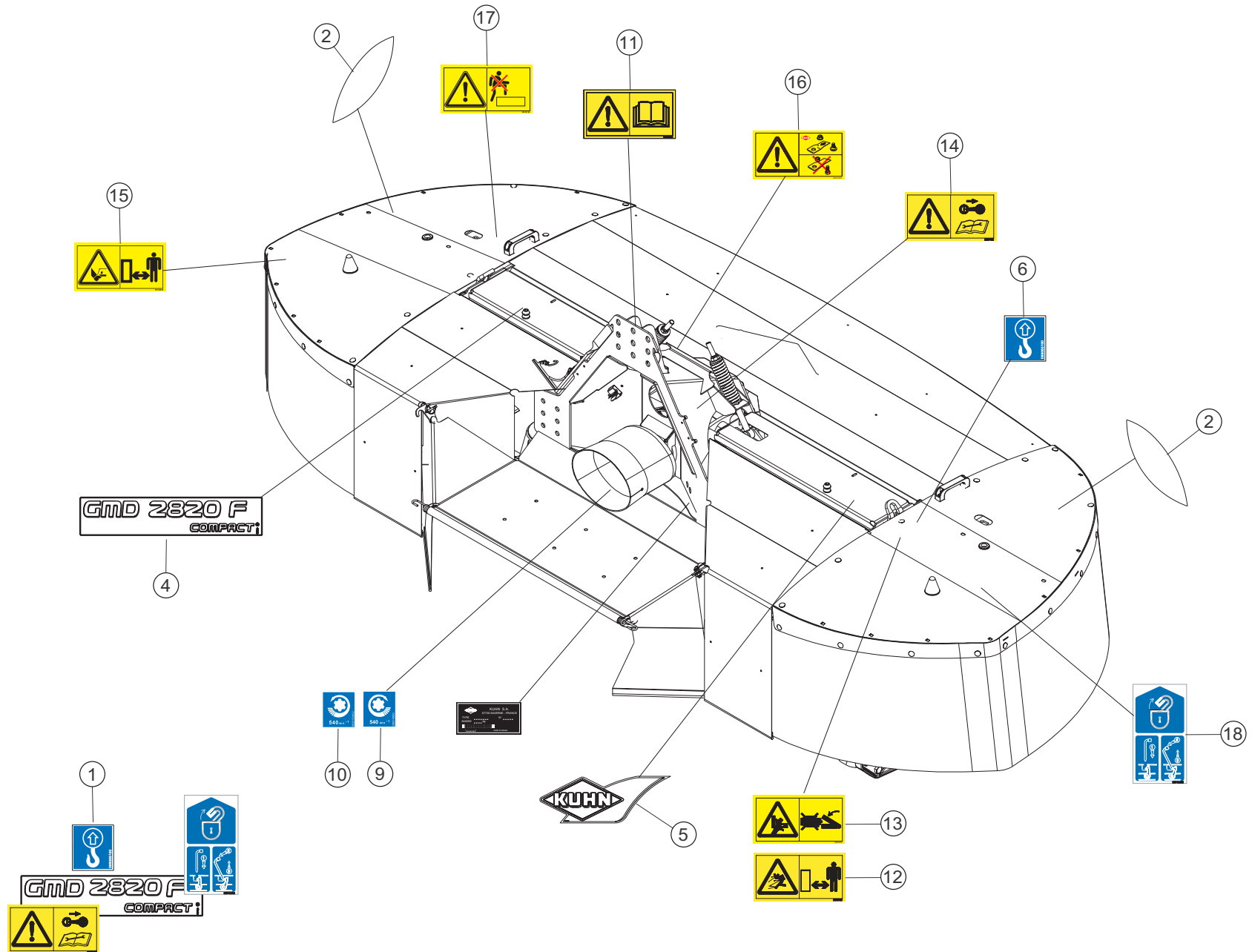



COLL.ETIQUETTES ADHESIVES

SET OF STICKERS

SATZ AUFKLEBER

SERIE ADESIVI

Rep	Nr	Qt	Designation	Description	Bezeichnung	Referenza	Remarque - Remark - Bemerkung - Osservazioni
001	K7019090	001	COLL.ETIQ.ADHES.	KIT, DECAL	SATZ AUFKLEBER	SERIE ADESIVI	+ [1]
001	K7019097	001	COLL.ETIQ.ADHES.GMD2820F CA	SET OF STICKERS CA	SATZ AUFKLEBER CA	SERIE ADESIVI CA	+ [1]
001	K7019098	001	COLL.ETIQ.ADHES.GMD2820F US	SET OF STICKERS US	SATZ AUFKLEBER US	SERIE ADESIVI US	+ [1]
002	K9501581	002	ETIQ.ADH.	DECAL	AUFKLEBER	ADESIVO	[1]
004	K9501810	001	ETIQ.ADH.	DECAL	AUFKLEBER	ADESIVO	[1]
005	K9530020	001	ETIQ.ADH.	DECAL	AUFKLEBER	ADESIVO	[1]
006	09905510	003	ETIQ.ADHESIVE POINT DE LEVAGE	DECAL LIFTING POINT	AUFKLEBER ANSCHLAGPUNKT	ADESIVO	[1]
009	09914900	001	ETIQ.ADHESIVE 540 MIN-1 A D.	TRANSFER	AUFKLEBER	ADESIVO	[1]
010	09915000	001	ETIQ.ADHESIVE 540 MIN-1 A.G.	DECAL	AUFKLEBER	ADESIVO	[1]
011	59900000	001	PICTOGR.H NOTICE D'INSTR	PICTORIAL H INSTRUCTIONS	PIKTOGR.H BETRIEBSANLEITUNG	ADESIVO	[1] *
012	59900200	003	PICTOGR.H DANGER PROJEC	PICTORIAL H DANGER PROJECTION	PIKTOGR.H GEFAHR FORTGESCHL.	ADESIVO	[1] *
013	59900300	002	PICTOGR.H ECRASEM.MAIN	PICTORIAL H CRUSH.DANGER HAND	PIKTOGR.H QUETSCHGEFAHR HAND	ADESIVO	[1] *
014	59900400	001	PICTOGR.H ARRETER MOTEUR	PICTORIAL H STOP ENGINE	PIKTOGR.H MOTOR ABSTELLEN	ADESIVO	[1] *
015	59900800	003	PICTOGR.H BLESSURE PIED	PICTORIAL H SEVERING OF FOOT	PIKTOGR.H FUSSVERLETZUNG	ADESIVO	[1] *
016	59901100	001	PICTOGR.H PIECES D'ORIGINE	PICTORIAL GENNINE PARTS	PIKTOGR.H ORIGINALTEILE	ADESIVO PEZZI ORIGINAL	[1] *
017	59901200	002	PICTOGR.H NE PAS MONTER	PICTORIAL H DO NOT STEP	PIKTOGR.H NICHT AUFSTEIGEN	ADESIVO	[1] *
018	59910300	003	PICTOGR.H DEVERROUILLAGE	PICTORIAL H UNLOCKING	PIKTOGR.H ENTRIEGELUNG	ADESIVO	[1] *

Pour les pictogrammes sans texte (standard CE) dont le code commence par 599xxxxx, le 7° chiffre est 0 ou 5.

Pour les pictogrammes avec texte, le 7° chiffre est respectivement:

1 ou 6 pour les pictogrammes avec texte français (standard du Canada francophone).

2 ou 7 pour les pictogrammes avec texte anglais (standard de pays anglophones non européens).

Safety pictorials without text (CE standard) with part no. starting with 599xxxxx, use 0 or 5 as the 7th digit of the number.

In the corresponding pictorials with text the 7th digit of the number is :

1 or 6 respectively for pictorials with French text as used in French Canada.

2 or 7 respectively for pictorials with English text as used in non-European English speaking countries.

Bei Sicherheitsaufklebern/Piktogrammen ohne Text (CE-Standard) mit Art.-Nr. 599xxxxx ist die 7. Ziffer 0 oder 5.

Bei den entsprechenden Sicherheitsaufklebern/Piktogrammen mit Text ist die 7. Ziffer:

1 oder 6 für Sicherheitsaufkleber/Piktogramme mit französischem Text (Serie im französischsprachigem Kanada)

2 oder 7 für Sicherheitsaufkleber/Piktogramme mit englischem Text (Serie in außereuropäischen englischsprachigen Ländern).

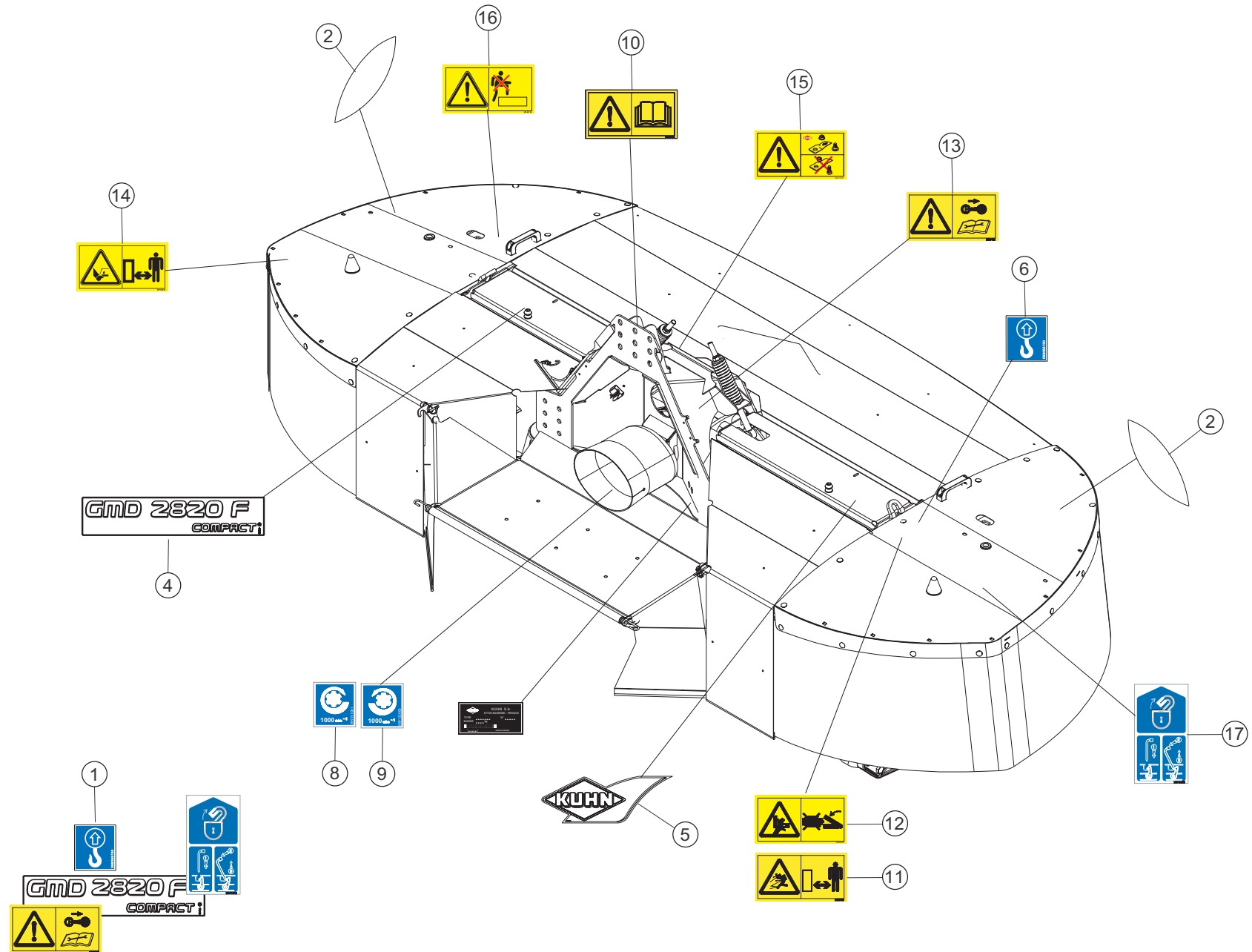



COLL.ETIQUETTES ADHESIVES

SET OF STICKERS

SATZ AUFKLEBER

SERIE ADESIVI

Rep	Nr	Qt	Designation	Description	Bezeichnung	Referenza	Remarque - Remark - Bemerkung - Osservazioni
001	K7019080	001	COLL.ETIQ.ADHES.	KIT, DECAL	SATZ AUFKLEBER	SERIE ADESIVI	+{1}
001	K7019087	001	COLL.ETIQ.ADHES.GMD2820F CA	SET OF STICKERS CA	SATZ AUFKLEBER CA	SERIE ADESIVI CA	+{1}
001	K7019088	001	COLL.ETIQ.ADHES.GMD2820F US	SET OF STICKERS US	SATZ AUFKLEBER US	SERIE ADESIVI US	+{1}
002	K9501581	002	ETIQ.ADH.	DECAL	AUFKLEBER	ADESIVO	[1]
004	K9501810	001	ETIQ.ADH.	DECAL	AUFKLEBER	ADESIVO	[1]
005	K9530020	001	ETIQ.ADH.	DECAL	AUFKLEBER	ADESIVO	[1]
006	09905510	003	ETIQ.ADHESIVE POINT DE LEVAGE	DECAL LIFTING POINT	AUFKLEBER ANSCHLAGPUNKT	ADESIVO	[1]
008	09915100	001	ETIQ.ADHESIVE 1000 MIN-1 A D.	DECAL 1000 MIN-1 RI.	AUFKLEBER 1000 MIN-1 RE.	ADESIVO	[1]
009	09915200	001	ETIQ.ADHESIVE 1000 MIN-1 A G.	DECAL 1000 MIN-1 LE.	AUFKLEBER 1000 MIN-1 LI.	ADESIVO	[1]
010	59900000	001	PICTOGR.H NOTICE D'INSTR	PICTORIAL H INSTRUCTIONS	PIKTOGR.H BETRIEBSANLEITUNG	ADESIVO	[1] *
011	59900200	003	PICTOGR.H DANGER PROJEC	PICTORIAL H DANGER PROJECTION	PIKTOGR.H GEFAHR FORTGESCHL.	ADESIVO	[1] *
012	59900300	002	PICTOGR.H ECRASEM.MAIN	PICTORIAL H CRUSH.DANGER HAND	PIKTOGR.H QUETSCHGEFAHR HAND	ADESIVO	[1] *
013	59900400	001	PICTOGR.H ARRETER MOTEUR	PICTORIAL H STOP ENGINE	PIKTOGR.H MOTOR ABSTELLEN	ADESIVO	[1] *
014	59900800	003	PICTOGR.H BLESSURE PIED	PICTORIAL H SEVERING OF FOOT	PIKTOGR.H FUSSVERLETZUNG	ADESIVO	[1] *
015	59901100	001	PICTOGR.H PIECES D'ORIGINE	PICTORIAL GENINE PARTS	PIKTOGR.H ORIGINALTEILE	ADESIVO PEZZI ORIGINAL	[1] *
016	59901200	002	PICTOGR.H NE PAS MONTER	PICTORIAL H DO NOT STEP	PIKTOGR.H NICHT AUFSTEIGEN	ADESIVO	[1] *
017	59910300	003	PICTOGR.H DEVERROUILLAGE	PICTORIAL H UNLOCKING	PIKTOGR.H ENTRIEGELUNG	ADESIVO	[1] *

Pour les pictogrammes sans texte (standard CE) dont le code commence par 599xxxxx, le 7° chiffre est 0 ou 5.

Pour les pictogrammes avec texte, le 7° chiffre est respectivement:

1 ou 6 pour les pictogrammes avec texte français (standard du Canada francophone).

2 ou 7 pour les pictogrammes avec texte anglais (standard de pays anglophones non européens).

Safety pictorials without text (CE standard) with part no. starting with 599xxxxx, use 0 or 5 as the 7th digit of the number.

In the corresponding pictorials with text the 7th digit of the number is :

1 or 6 respectively for pictorials with French text as used in French Canada.

2 or 7 respectively for pictorials with English text as used in non-European English speaking countries.

Bei Sicherheitsaufklebern/Piktogrammen ohne Text (CE-Standard) mit Art.-Nr. 599xxxxx ist die 7. Ziffer 0 oder 5.

Bei den entsprechenden Sicherheitsaufklebern/Piktogrammen mit Text ist die 7. Ziffer:

1 oder 6 für Sicherheitsaufkleber/Piktogramme mit französischem Text (Serie im französischsprachigem Kanada)

2 oder 7 für Sicherheitsaufkleber/Piktogramme mit englischem Text (Serie in außereuropäischen englischsprachigen Ländern).

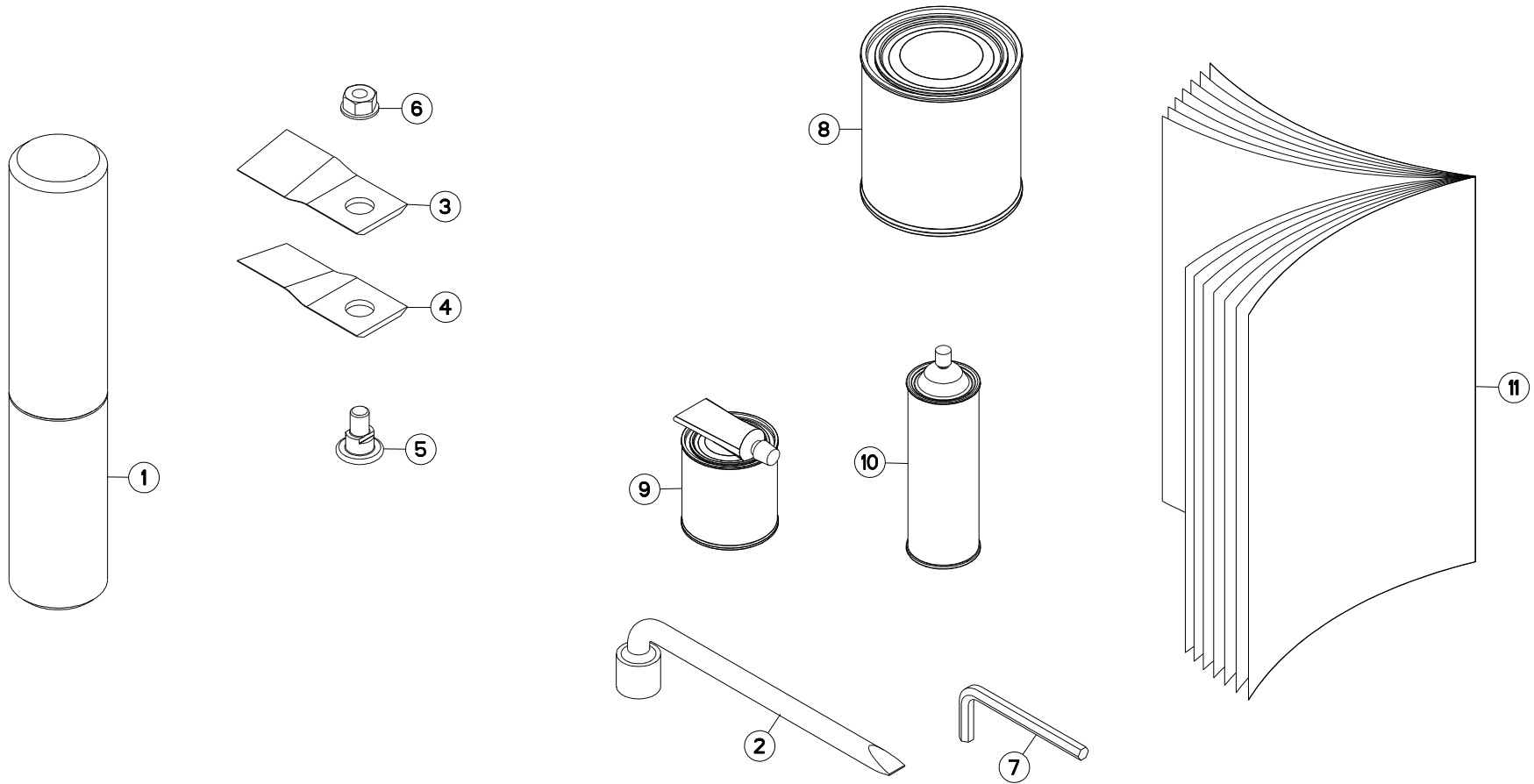



GMD2820F 1000
GMD2820F 540

B 0001 > C 0000
B 0001 > C 0000

K70R0722 B

DIVERS

MISCELLANEOUS

VERSCHIEDENES

VARIE

Rep	Nr	Qt	Designation	Description	Bezeichnung	Referenza	Remarque - Remark - Bemerkung - Osservazioni
001	9006600	001	PORTE-DOCUMENTS TUBULAIRE	DOCUMENT BOX	GEWINDEPACK	PORTADUCOMANTI TUBOLARE	
002	50080200	001	CLE A PIPE DE 18 (12PANS)	BOX SPANNER 18	PFEIFENSCHLUESSEL 18	CHIAVE X FC 280F MATR.95	
003	55903210	006	COUTEAU VRILLE T.A.G ISO5718	ANGLED BLADE LEFT TURN.ISO5718	GEKROEP.MESS.LINKSDREH.ISO5718	COLTEL.PIEGATO STD-SX ISO5718	
004	55903310	006	COUTEAU VRILLE T.A.D ISO5718	ANGLED BLAD.RIGHT TURN.ISO5718	GEKROEP.MESS.RECHTSDRE.ISO5718	COLTEL.PIEGATO STD-DX ISO5718	
005	56115800	006	VIS AUTOFREINEE	SCREW, SELF-LOCKING	SELBSTSICHERNDE SCHRAUBE	VITE AUTOBLOCCANTE	
006	80201262	006	ECROU TWOLOCK FLZNNC	SELF-LOCKING NUT FLZNNC	SELBSTSICHERNDE MUTTER FLZNNC	DADO TWOLOCK FLZNNC	
007	83450005	001	CLE MALE 8	ALLEN WRENCH 8	6KT.STIFTSCHLUESSEL 8	CHIAVE	
008	83503018	001	BOITE 1L PEINT.ROUGE	1L RED PAINT CAN,	DOSE FARBE ROT,1L	VERNICE ROSSA KUHN	OPT
009	83503019	001	KIT RAL2002 0,5+0,1 KG BICOMP	KIT RAL2002 0,5+0,1 KG 2 COMP	KIT RAL2002 0,5+0,1 KG 2KOMP	VERNICE RAL2002 2K 0,5+0,1 KG	OPT
010	83503026	001	AEROSOL ROUGE RAL2002 BR.	RED SPRAY PAINT	FARBSPRUEHDOSE KUHN ROT	VERNICE SPRAY ROSSA	OPT
011	KN154B	001	NOTICE D'INST.	OPERATOR'S MANUAL	BETRIEBSANLEITUNG	MANUALE D'USO E MANUTENZIONE	

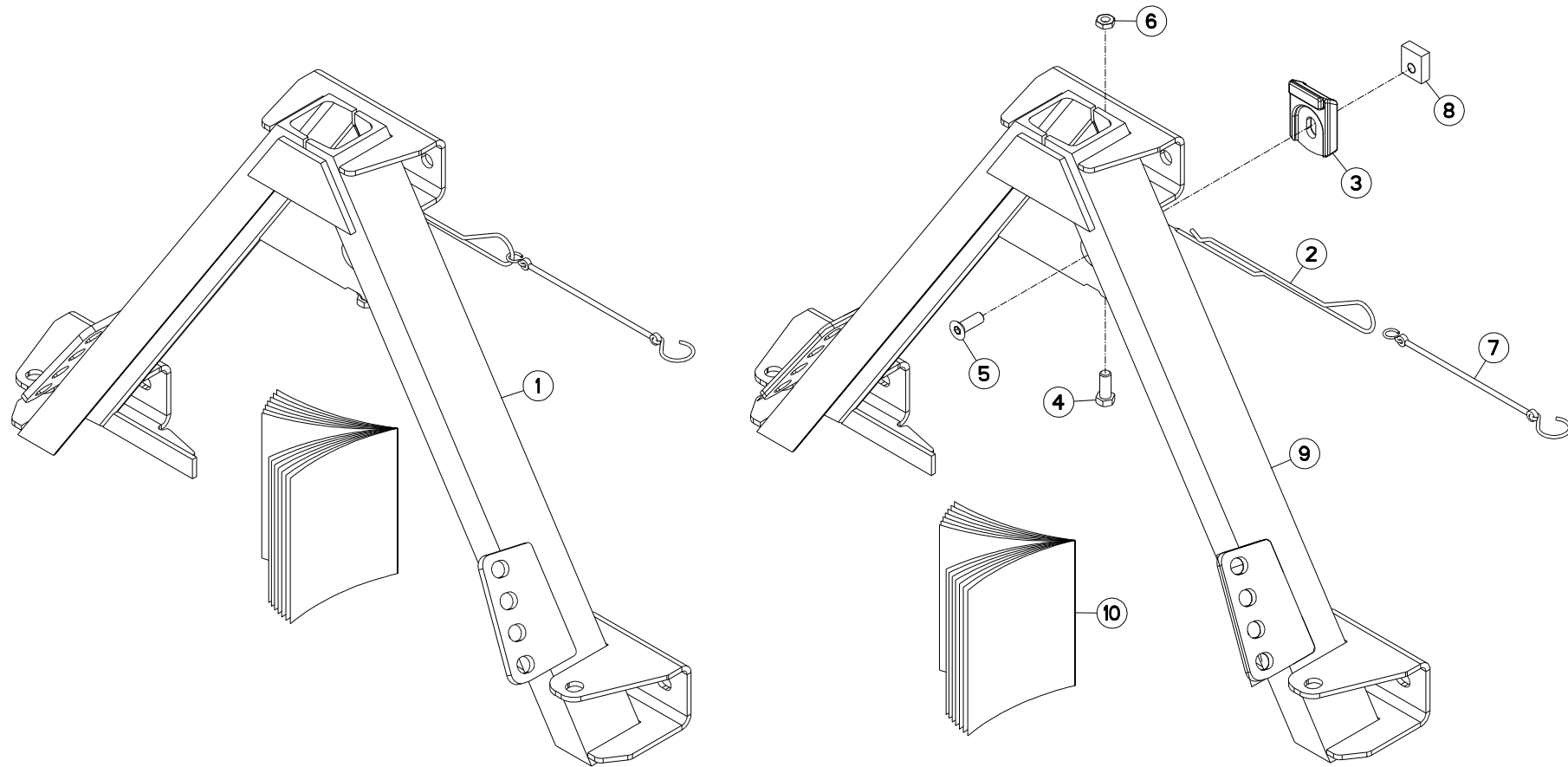



GMD2820F 1000
GMD2820F 540

B 0001 > C 0000
B 0001 > C 0000

K70R0569 A

TRIANGLE D'ATTELAGE

ATTACHMENT FRAME

ANBAUDREIECK

ATTACO A TRE PUNTI

Rep	Nr	Qt	Designation	Description	Bezeichnung	Referenza	Remarque - Remark - Bemerkung - Osservazioni
001	1036370	001	TRIANGLE ATTEL.FRONT.FEM.	TRIANGLE ATTACHMENT SET FEM.	GERAETESEITIGES ANBAUDREIECK	TRIANGOLO ATTACCAT.FEMMINILE	OPT +[1]
002	56617500	001	EPINGLE	PIN, COTTER, HAIRPIN	FEDERSTECKER	PERNO A MOLLA	[1]
003	57556310	001	VERROU	LATCH	RIEGEL	LEVA	[1]
004	80061271	001	VIS TETE HEXAGONALE FE/ZNXC3	HEX BOLT FE/ZNXC3	SECHSKANTSCHRAUBE FE/ZNXC3	VITE TESTA ESAGONALE FE/ZNXC3	[1]
005	80111243	001	VIS T.FRAI.SIX P.CR.FE/ZNXC3	HEX.SOC.COUNT.HEAD SC.FE/ZNXC3	SENKSCHEUB.INNENS. FE/ZNXC3	VITE FE/ZNXC3	[1]
006	80201271	001	ECROU HEXAGONAL BAS FE/ZNXC3	NUT FE/ZNXC3	SECHSKANTMUTTER FE/ZNXC3	DADO FE/ZNXC3	[1]
007	83070064	001	LIEN PVC	PVC CORD	SICHERUNGSBAND	CAVO	[1]
008	K7003460	001	PATTE ZBC	PLATE ZBC	LASCHE ZBC	FAZZOLETTO ZBC	[1]
009	K7017310	001	COUPLEUR	COUPLER	KUPPLER	GIUNTO	[1]
010	KE0075TL	001	NOTICE D'EQUIP.COLL.1036370	MANUAL OPTIONAL EQUIPMENT	ANLEITUNG SONDERAUSRÜSTUNG	MAN. EQUIPAGGIAMENTI OPZIONE	[1]

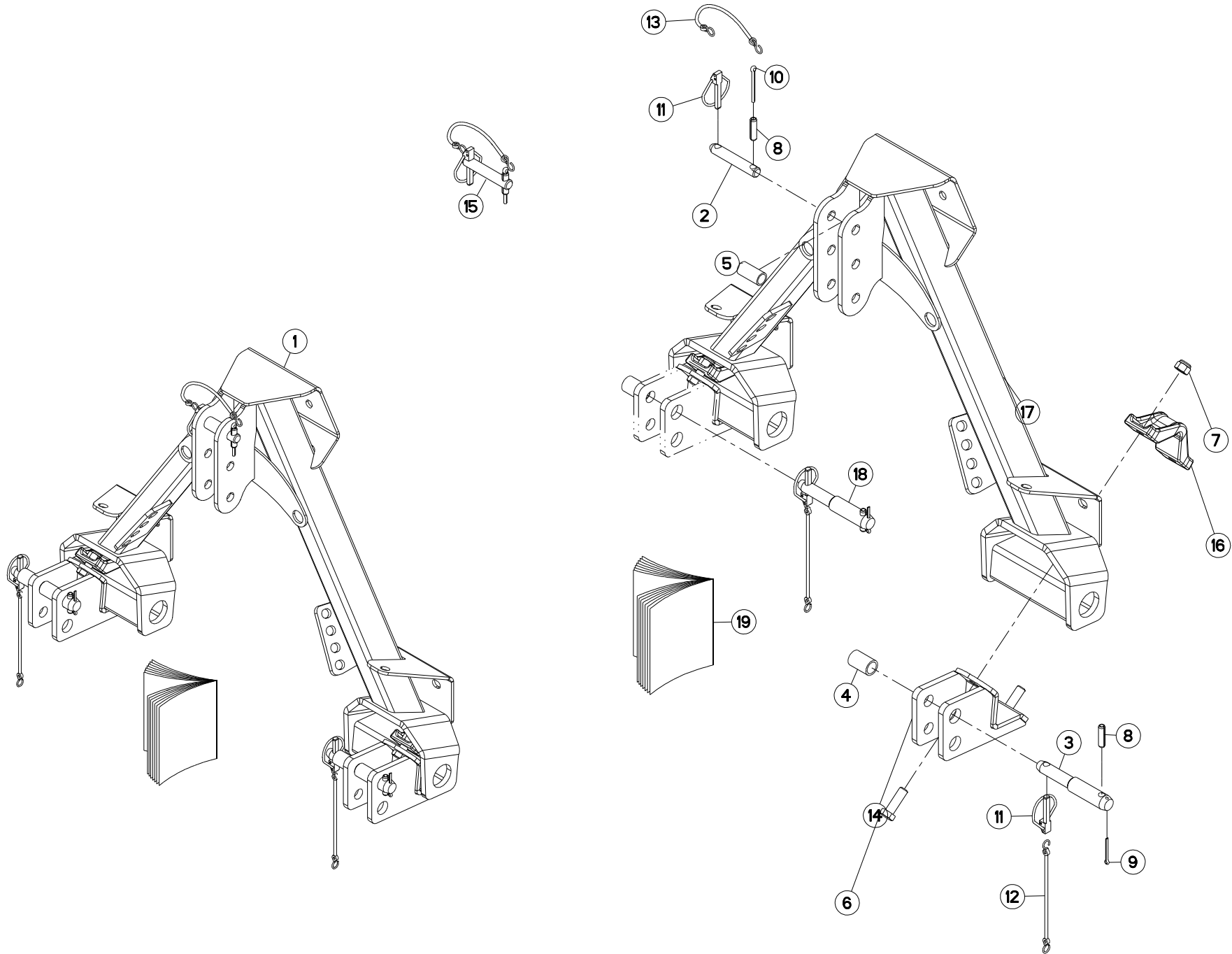



GMD2820F 1000
GMD2820F 540

B 0001 > C 0000
B 0001 > C 0000

K70R0570 C

CADRE 3 POINTS

3 POINT FRAME

DREIPUNKTBOCK

TIMONE

Rep	Nr	Qt	Designation	Description	Bezeichnung	Referenza	Remarque - Remark - Bemerkung - Osservazioni
001	1036380	001	COLL.CADRE 3 PTS FRON.CAT.1-2	3 POINT FRAME SET CAT.1-2	3 PUNKTRAHMENSATZ KAT.1-2	3 PUNTI TELAIO CAT.1-2	OPT +[1]
002	51504100	001	TOURILLON	TRUNNION	DREHZAPFEN	PERNI	[2]
003	52234410	002	TOURILLON	TRUNNION	DREHZAPFEN	PERNI	[3]
004	52253200	002	DOUILLE DE POSITIONNEMENT	BUSH	HUELSE	BOCCOLA	[1][3]
005	58532000	001	DOUILLE CAT.II	SOCKET CAT.II	HUELSE KAT.II	BOCCOLA	[1]
006	80061651	004	VIS TETE HEXAGONALE FE/ZNXC3	HEXAGON HEAD SCREW FE/ZNXC3	SECHSKANTSCHRAUBE FE/ZNXC3	VITE TESTA ESAGONALE FE/ZNXC3	[1]
007	80201630	004	ECROU HEX.AUTOFREINE FE/ZNXC3	SELF-LOCKING NUT FE/ZNXC3	SELBSTSICH.MUTTER FE/ZNXC3	DADO AUTOBLOCCANTE FE/ZNXC3	[1]
008	80451246	003	GOUPILLE ELASTIQUE FLZNNC	ROLL PIN FLZNNC	SPANNHUELSE FLZNNC	SPINA ELASTICA FLZNNC	[2]
009	80500445	002	GOUPILLE FENDUE FE/ZNXC3	SPLIT PIN FE/ZNXC3	SPLINT FE/ZNXC3	COPPIGLIA FE/ZNXC3	[1][3]
010	80500565	001	GOUPILLE FENDUE FE/ZNXC3	SPLIT PIN FE/ZNXC3	SPLINT FE/ZNXC3	COPPIGLIA FE/ZNXC3	[2]
011	80561155	003	GOUPILLE AUTOMATIQUE	LINCH PIN	KLAPPSTECKER	SPINA DI FERMO	[2][3]
012	83070063	002	LIEN PVC	PVC CORD	SICHERUNGSBAND	CAVETTO	[3]
013	83070063	001	LIEN PVC	PVC CORD	SICHERUNGSBAND	CAVETTO	[3]
014	K1602060	002	CHAPE INFERIEURE SOUDEE	YOKE	GABEL	FORCELLA	[1]
015	K1620620	001	TOURILLON DU 3.POINT CPLT	PIN CPLT	BOLZEN KPLT	PERNO	[1] +[2]
016	K1631170	002	BRIDE DE CHAPE	BRIDLE	BUEGEL	STAFFA	[1]
017	K7017432	001	CADRE	FRAME	RAHMEN	TELAIO	[1]
018	K7019570	002	BROCHE	PIN, HITCH	ACHSE	PERNO	[1] +[3]
019	KE0076TL	001	NOTICE D'EQUIP.COLL.1036380	MANUAL OPTIONAL EQUIPMENT	ANLEITUNG SONDERAUSRÜSTUNG	MAN. EQUIPAGGIAMENTI OPZIONE	[1]

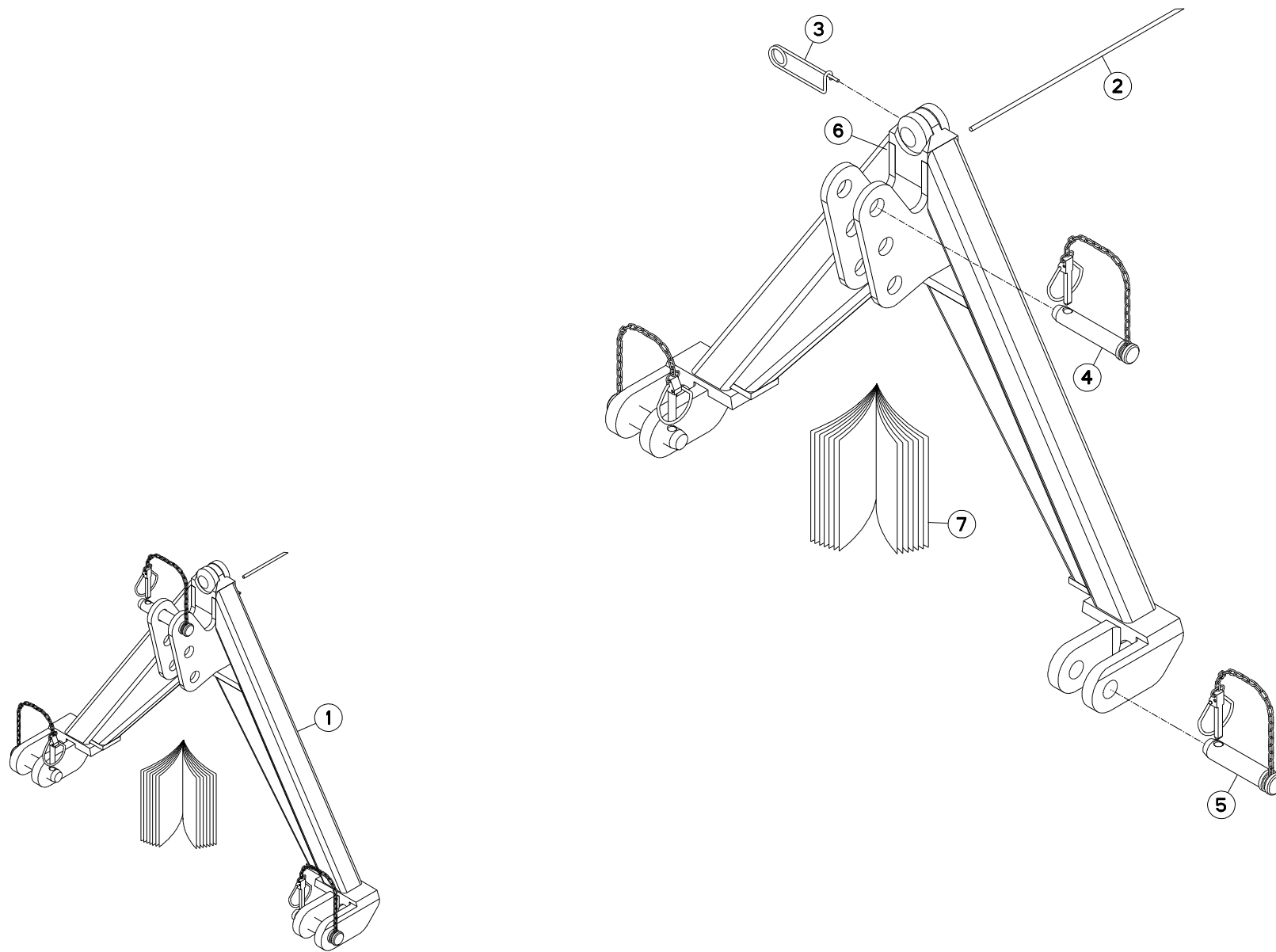



GMD2820F 1000
GMD2820F 540

B 0001 > C 0000
B 0001 > C 0000

K70R0617 B

TRIANGLE D'ATTELAGE

ATTACHMENT FRAME

ANBAUDREIECK

ATTACO A TRE PUNTI

Rep	Nr	Qt	Designation	Description	Bezeichnung	Referenza	Remarque - Remark - Bemerkung - Osservazioni
001	1276870	001	TRIANGLE D'ATTELAGE CAT 2S	TRACTOR A FRAME CAT.2S	SCHLEPPERDREIECK KAT.2S	ATT.TRIANGOLO CAT2S	OPT +[1]
002	58814900	001	CORDE NYLON	NYLON STRING	NYLONSEIL	CORDA NYLON	[1]
003	80510460	001	GOUVILLE DE SECURITE FE/ZNXC3	SAFETY PIN FE/ZNXC3	SICHERHEITSNADDEL FE/ZNXC3	COPPIGLIA FE/ZNXC3	[1]
004	A7160104	001	AXE D'ATTELAGE PT HAUT D25,4	AXLE D25,4	BOLZEN D25,4	PERNO DI FISSAGGIO D=25,4	[1]
005	K3101420	002	AXE	PIN	ACHSE	ASSE	[1]
006	K7022590	001	TRIANGLE D'ATTELAGE NU CAT.2S	FRAME, HITCH	DREIPUNKTBOCK	TRIANGOLO D'ATTACCO	[1]
007	KE0135TL	001	NOTICE D'EQUIP.COLL.1276870	MANUAL OPTIONAL EQUIPMENT	ANLEITUNG SONDERAUSRÜSTUNG	MAN. EQUIPAGGIAMENTI OPZIONE	[1]

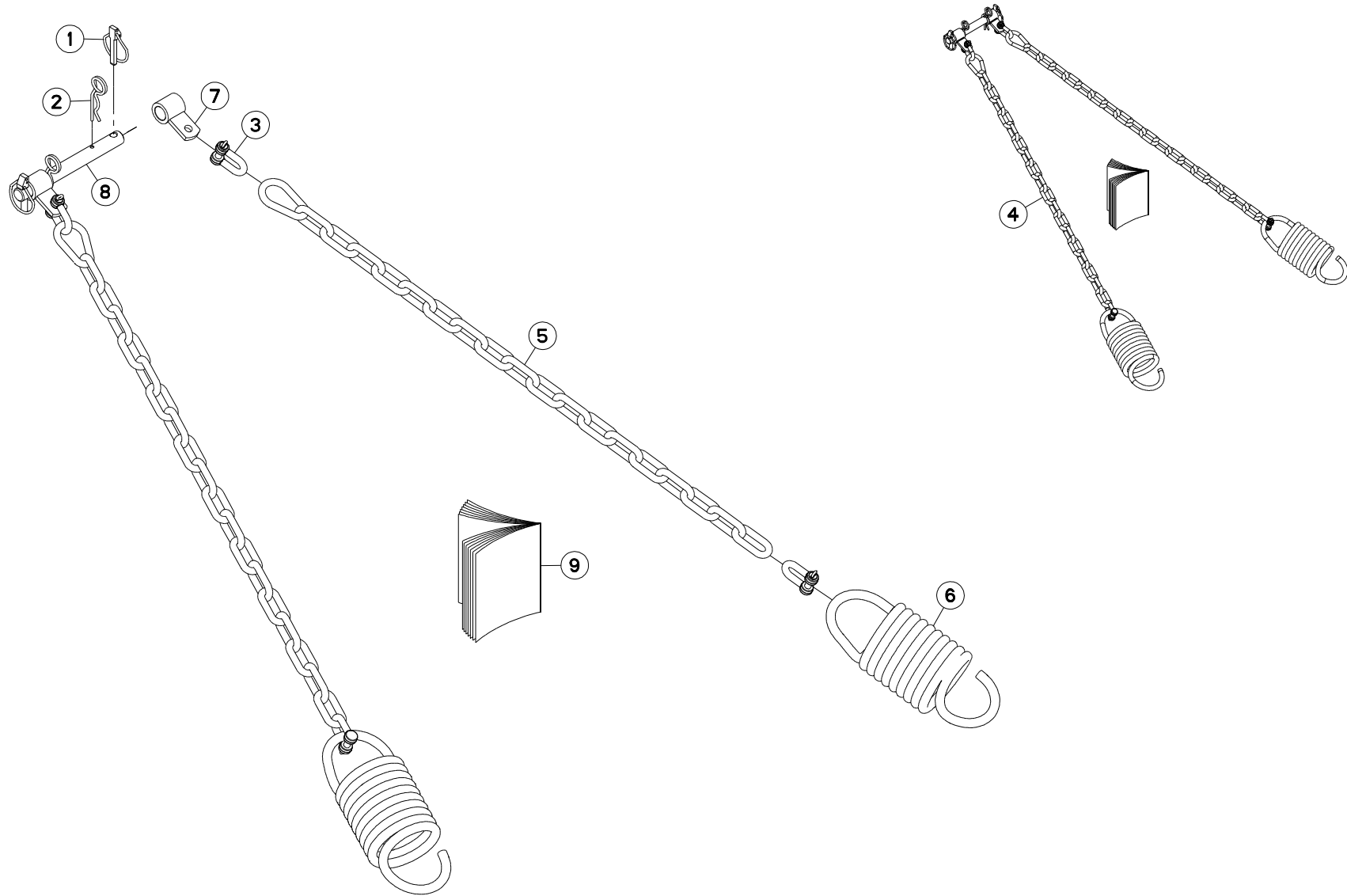



GMD2820F 1000
GMD2820F 540

B 0001 > C 0000
B 0001 > C 0000

K70R0571 A

RESSORT DE COMPENSATION

COMPENSATION SPRING

ENTLASTUNGSFEDER

MOLLA DE COPENSAZIONE

Rep	Nr	Qt	Designation	Description	Bezeichnung	Referenza	Remarque - Remark - Bemerkung - Osservazioni
001	80561155	002	GOUPILLE AUTOMATIQUE	LINCH PIN	KLAPPSTECKER	SPINA DI FERMO	[1]
002	80570500	002	GOUPILLE BETA SIMPLE FE/ZNXC3	SPRING COTTER PIN FE/ZNXC3	FEDERSTECKER FE/ZNXC3	MOLLA FE/ZNXC3	[1]
003	83070056	004	MANILLE CALIBREE FE/ZNXC3	SHACKLE FE/ZNXC3	SCHAEKEL FE/ZNXC3		[1]
004	1036390	001	COLL.RESSORT D'ALLEGEMENT	COMPENSAT.SPRING SET	ENTLASTUNGSFEDER SATZ	KIT MOLLA COMPENS.	OPT +[1]
005	K7015890	002	CHAINE	CHAIN	KETTE	CATENA	[1]
006	K7022580	002	RESSORT DE TRACTION	SPRING, EXTENSION	ZUGFEDER	MOLLA DI TRAZIONE	[1]
007	K7024810	002	ATTACHE	ATTACHMENT	HALTERUNG	ATTACCO	[1]
008	K7024830	001	TOURILLON	TRUNNION	DREHZAPFEN	PERNI	[1]
009	KE0112TL	001	NOTICE D'EQUIP.COLL.1036390	MANUAL OPTIONAL EQUIPMENT	ANLEITUNG SONDERAUSRÜSTUNG	MAN. EQUIPAGGIAMENTI OPZIONE	[1]

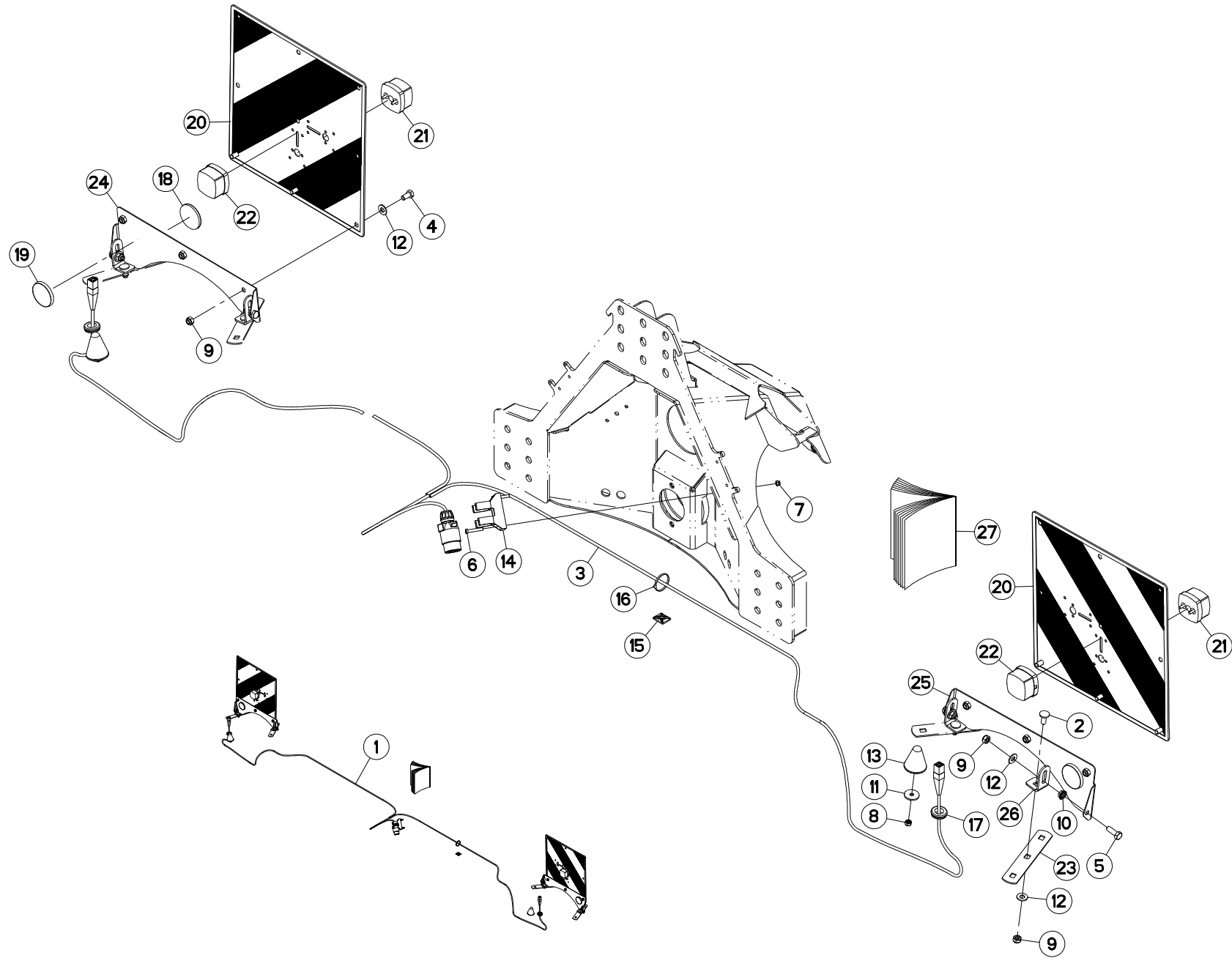



GMD2820F 1000
GMD2820F 540

B 0001 > C 0000
B 0001 > C 0000

K70R0572 B

SIGNALISATION

SIGNALLING

BELEUCHTUNG U. WARNTAFELN

SEGNALAZIONE

Rep	Nr	Qt	Designation	Description	Bezeichnung	Referenza	Remarque - Remark - Bemerkung - Osservazioni
001	1036410	001	COLL.SIGNALISA.GMD2820F/3120F	SET WARNING BOARDS GMD2820F/31	SATZ BELEUC.+WARNTAF.GMD1020 F	KIT ILLUM.SEGN.GMD2820F/3120F	OPT +[1]
002	50002200	004	VIS TBCC COURT	BOLT, CARRIAGE, SHORT NECK	FLACHRUNDSCHR.4KT ANSATZ	BULLONE	[1]
003	56676800	001	FAISCEAU ELECTRIQUE	WIRING HARNESS	KABELNETZ	FASCIO DE CONDUTTORI	[1]
004	80061020	006	VIS TETE HEXAGONALE FE/ZNXC3	HEX. HEAD SCREW FE/ZNXC3	SECHSKANTSCHRAUBE FE/ZNXC3	VITE A TESTA ESAGONALE FE/ZNXC	[1]
005	80061073	004	VIS TETE HEXAGONALE FE/ZNXC3	HEXAGON HEAD SCREW FE/ZNXC3	SECHSKANTSCHRAUBE FE/ZNXC3	VITE TESTA ESAGONALE FE/ZNXC3	[1]
006	80080636	002	VIS TETE CYL.SIX P.CR.FE/ZNXC3	SCREW, SOCKET HEAD FE/ZNXC3	ZYLINDERSCHR.INNENSEC.FE/ZNXC3	VITE A TESTA CILINDR. FE/ZNXC3	[1]
007	80200630	002	ECROU HEX.AUTOFREINE FE/ZNXC3	SELF LOCKING NUT FE/ZNXC3	SELBSTSICHERNDE MUTT.FE/ZNXC3	DADO AUTOBLOCCANTE FE/ZNXC3	[1]
008	80200840	002	ECROU HEX.BAS AUTOFR.FE/ZNXC3	SELF-LOCKING NUT FE/ZNXC3	SELBSTSICHERND.MUTTER FE/ZNXC3	DADO AUTOBLOCCANTE FE/ZNXC3	[1]
009	80201040	014	ECROU HEX.BAS AUTOFR.FE/ZNXC3	SELF LOCKING NUT FE/ZNXC3	SELBSTSICHERND.MUTTER FE/ZNXC3	DADO AUTOBLOCCANTE FE/ZNXC3	[1]
010	80201053	004	ECROU AUTOBLOQUANT FE/ZNXC3	UNDERSERRAT.S.LOC.NUT FE/ZNXC3	SPERRZAHN-BUNDMUTTER FE/ZNXC3	DADO FE/ZNXC3	[1]
011	80250934	002	RONDELLE PLATE FE/ZNXC3	PLAIN WASHER FE/ZNXC3	SCHEIBE FE/ZNXC3	RONDELLA PIATTA FE/ZNXC3	[1]
012	80251176	014	RONDELLE PLATE FE/ZNXC3	PLAIN WASHER FE/ZNXC3	SCHEIBE FE/ZNXC3	RONDELLA PIATTA FE/ZNXC3	[1]
013	83030011	002	BUTEE ELASTIQUE	RUBBER STOP	GUMMIPUFFER	GOMMINO	[1]
014	83090037	001	SUPPORT DE PRISE 7 POLES	PLUG SUPPORT	STECKERHALTERUNG	SUPPORTO	[1]
015	83090038	020	EMBASE AUTOADHESIVE	SELF STIKING CABLE GUIDE	KABELKONSOLE SELBSTKLEBEND	BASAMENTO	[1]
016	83090039	030	COLLIER PLASTIQUE	CABLE TIE PLASTIC	KABELBINDER PLASTIK	FASCETTE FERMACAVI	[1]
017	83200801	002	PASSE FIL	RUBBER PASS WIRE	GUMMI-TUELLE	PASSAFILO	[1]
018	83240010	002	CATADIOPTRE	REFLECTOR	RUECKSTRAHLER	CATADIOTTRO	[1]
019	83240011	002	CATADIOPTRE ROUGE 60 ADHESIF	REFLECTOR RED ADHESIVE	RUECKSTRAHLER ROT SELBSTKL.	CATADIOTRI	[1]
020	83240202	002	PANNEAU DE SIGNAL.DOUBLE-FACE	WARNING PLATE	WARNTAFEL	PANNELLO DI SEGNALAZIONE	[1]
021	83240404	002	FEU DE POSITION BLANC	FRONT LAMP WHITE	BEGRENZUNGSLICHT WEISS	FANALINO BIANCO	[1]
022	83240405	002	FEU DE POSITION ROUGE	RED TAIL LAMP	BEGRENZUNGSLICHT ROT	FANALINO ROSSO	[1]
023	K7019980	004	CONTRE-PLAQUE	PLATE, BACKER	BEFESTIGUNGSPLATTE	PIASTRINA	[1]
024	K7020330	001	SUPPORT	SUPPORT	TRAEGER	SUPPORTO	[1]
025	K7020340	001	SUPPORT	SUPPORT	TRAEGER	SUPPORTO	[1]
026	K7020750	004	EQUERRE	GUSSET, CORNER	WINKEL	SQUADRA	[1]
027	KE0077TL	001	NOTICE D'EQUIP.COLL.1036410	MANUAL OPTIONAL EQUIPMENT	ANLEITUNG SONDERAUSRÜSTUNG	MAN. EQUIPAGGIAMENTI OPZIONE	[1]

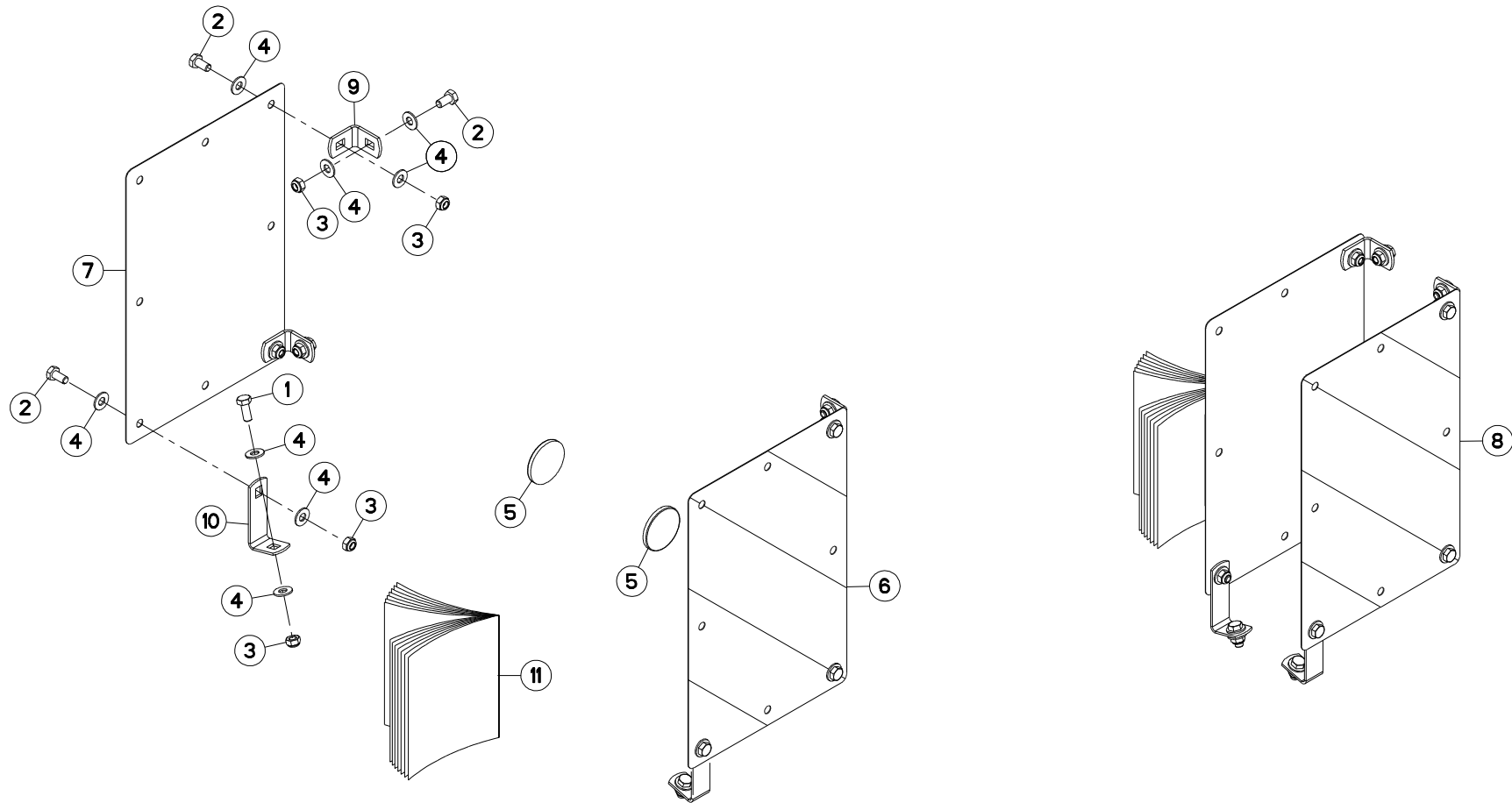



GMD2820F 1000
GMD2820F 540

B 0001 > C 0000
B 0001 > C 0000

K70R0654 A

SIGNALISATION LATERALE

SIDE SIGNALLING

SEITLICHE WARNTAFELN

SEGNALAZIONE LATERALI

Rep	Nr	Qt	Designation	Description	Bezeichnung	Referenza	Remarque - Remark - Bemerkung - Osservazioni	
001	80061026	002	VIS TETE HEXAGONALE FE/ZNXC3	HEXAGON HEAD SCREW FE/ZNXC3	SECHSKANTSCHRAUBE FE/ZNXC3	VITE TESTA ESAGONALE FE/ZNXC3	[1]	
002	80061020	010	VIS TETE HEXAGONALE FE/ZNXC3	HEX. HEAD SCREW FE/ZNXC3	SECHSKANTSCHRAUBE FE/ZNXC3	VITE A TESTA ESAGONALE FE/ZNXC3	[1]	
003	80201040	012	ECROU HEX.BAS AUTOFR.FE/ZNXC3	SELF LOCKING NUT FE/ZNXC3	SELBSTSICHERND.MUTTER FE/ZNXC3	DADO AUTOBLOCCANTE FE/ZNXC3	[1]	
004	80251176	024	RONDELLE PLATE FE/ZNXC3	PLAIN WASHER FE/ZNXC3	SCHEIBE FE/ZNXC3	RONDELLA PIATTA FE/ZNXC3	[1]	
005	83240014	002	CATADIOPTRE	REFLECTOR	RUECKSTRAHLER	CATADIOTTRO	[1]	
006	83240209	001	PANNEAU DE SIGNAL.RECT.ARD-AVG	WARNING PLATE	WARNTAFEL HI-RE + VO-LI	PANNELLO	[1]	
007	83240210	001	PANNEAU DE SIGNAL.RECT.ARG-AVD	WARNING PLATE	WARNTAFEL HI-LI + VO-RE	PANNELLO	[1]	
008	1016410	001	COLL.SIGNALISA.LATERALE CDR FR	SET OF SIDE WARNING BOARDS FR	SATZ SEIT WARNTAFELN FR	IMP.PANN.SEGN. FR	OPT	+ [1]
009	K6801520	004	EQUERRE	GUSSET, CORNER	WINKEL	SQUADRA	[1]	
010	K6801540	002	EQUERRE	GUSSET, CORNER	WINKEL	SQUADRA	[1]	
011	KE0099TL	001	NOTICE D'EQUIP.COLL.1016410	MANUAL OPTIONAL EQUIPMENT	ANLEITUNG SONDERAUSRÜSTUNG	MAN. EQUIPAGGIAMENTI OPZIONE	[1]	

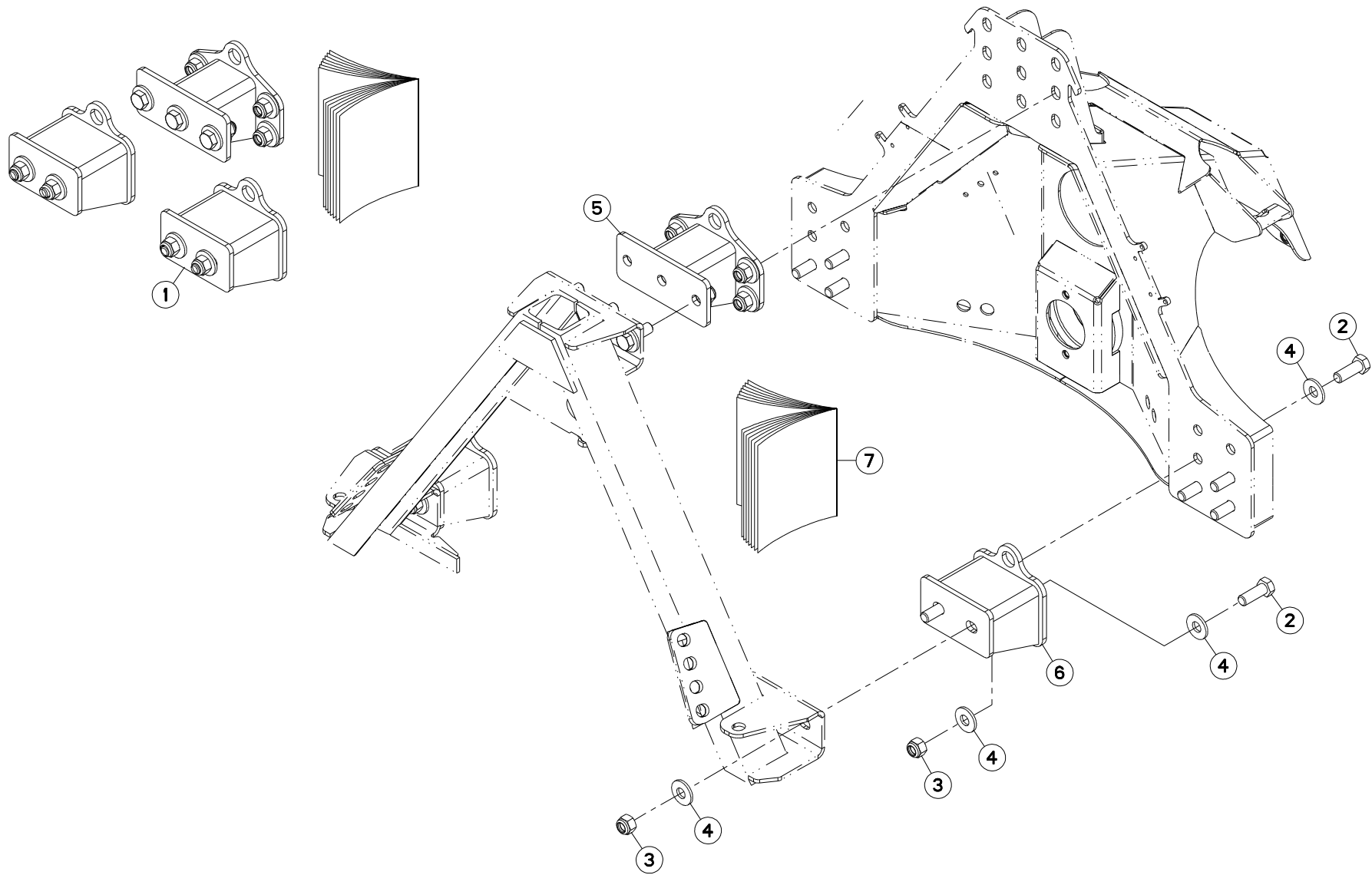



GMD2820F 1000
GMD2820F 540

B 0001 > C 0000
B 0001 > C 0000

K70R0616 A

DEPORT 120 MM

OFF SETTING 120 MM

VORDERFURCHEINSTELLUNG 120 MM

SFALSAMENTO 120 MM

Rep	Nr	Qt	Designation	Description	Bezeichnung	Referenza	Remarque - Remark - Bemerkung - Osservazioni
001	1036430	001	COLL.DEPORT ATTELAGE 120MM	FRAME OFF SET KIT 120MM	RAHMENVERSATZ 120MM		OPT +[1]
002	80061646	014	VIS TETE HEXAGONALE FE/ZNXC3	HEXAGON HEAD SCREW FE/ZNXC3	SECHSKANTSCHRAUBE FE/ZNXC3	VITE TESTA ESAGONALE FE/ZNXC3	[1]
003	80201630	021	ECROU HEX.AUTOFREINE FE/ZNXC3	SELF-LOCKING NUT FE/ZNXC3	SELBSTSICH.MUTTER FE/ZNXC3	DADO AUTOBLOCCANTE FE/ZNXC3	[1]
004	80281639	035	RONDELLE RESSORT FLZNNC	CONICAL SPRING WASHER FLZNNC	SPANNSCHEIBE FLZNNC	RONDELLA A MOLLA FLZNNC	[1]
005	K7019690	001	ENTRETOISE	SPACER	DISTANZHUELSE	DISTANZIALE	[1]
006	K7019700	002	ENTRETOISE	SPACER	DISTANZHUELSE	DISTANZIALE	[1]
007	KE0117TL	001	NOTICE D'EQUIP.COLL.1036430	MANUAL OPTIONAL EQUIPMENT	ANLEITUNG SONDERAUSRÜSTUNG	MAN. EQUIPAGGIAMENTI OPZIONE	[1]

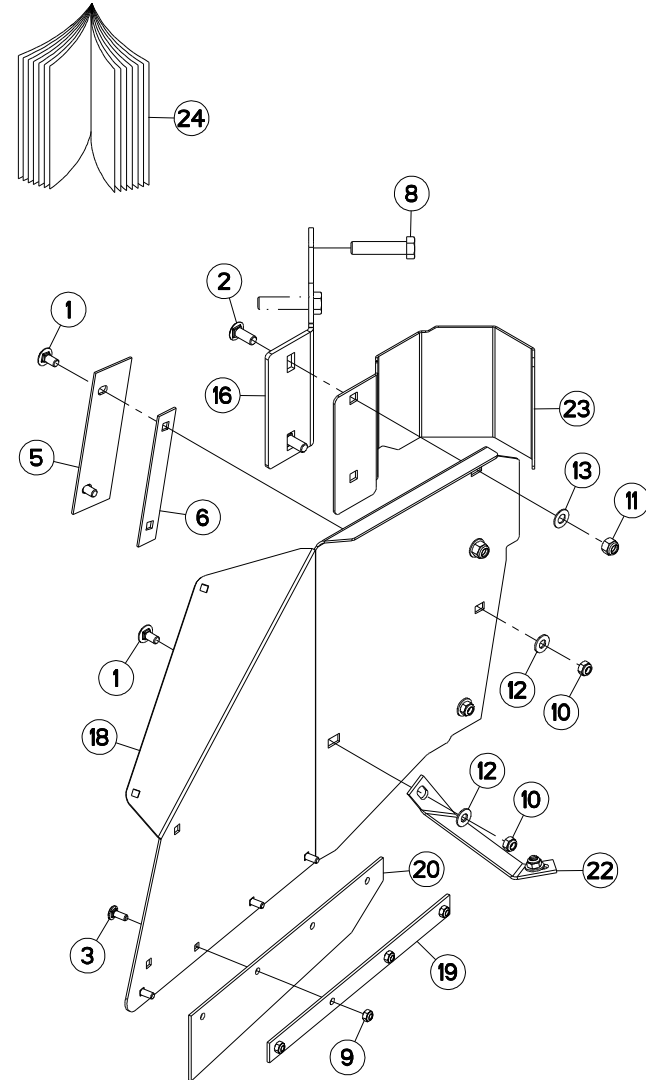
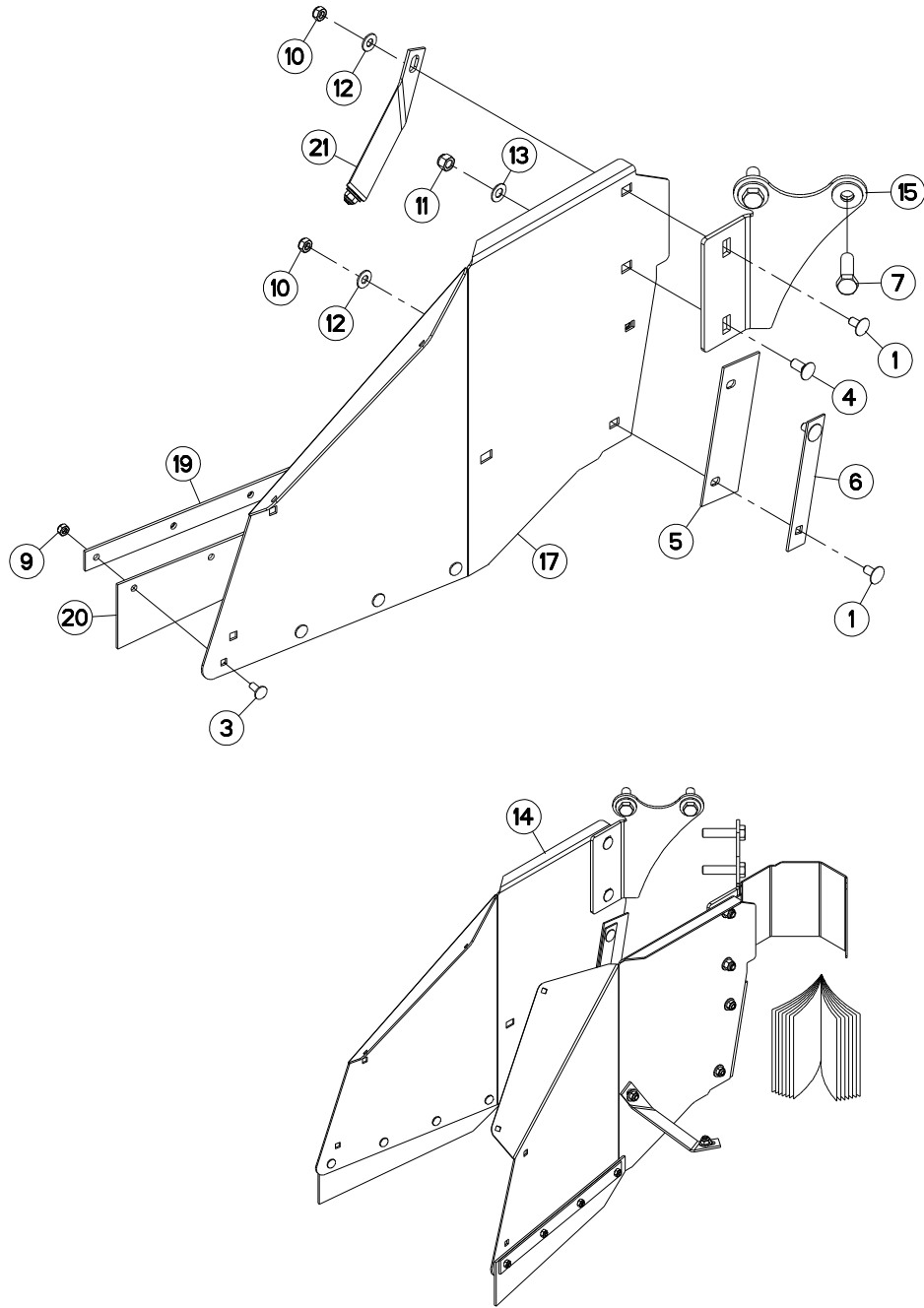



GMD2820F 1000
GMD2820F 540

B 0001 > C 0000
B 0001 > C 0000

K70R0727 A

TOLES A ANDAINS

SWATH BOARDS

SCHWADBLECHE

LAMIERE PER ANDANE

Rep	Nr	Qt	Designation	Description	Bezeichnung	Referenza	Remarque - Remark - Bemerkung - Osservazioni
001	50003200	008	VIS TBCC COURT	BOLT, CARRIAGE, SHORT NECK	FLACHRUNDSCHR.4KT ANSATZ	BULLONE	[1]
002	50068900	002	VIS TBCC COURT	BOLT, CARRIAGE, SHORT NECK	FLACHRUNDSCHR.4KT ANSATZ	BULLONE	[1]
003	50070300	008	VIS TBCC COURT	BOLT, CARRIAGE, SHORT NECK	FLACHRUNDSCHR.4KT ANSATZ	BULLONE	[1]
004	50070800	001	VIS TBCC COURT	BOLT, CARRIAGE, SHORT NECK	FLACHRUNDSCHR.4KT ANSATZ	BULLONE	[1]
005	56012810	002	BAVETTE	FLAP	SCHUTZLAPPEN	PARASPRUZZI	[1]
006	56012900	002	CONTRE-PLAQUE	PLATE, BACKER	BEFESTIGUNGSPLATTE	PIASTRINA	[1]
007	80061647	002	VIS TETE HEXAGONALE FE/ZNXC3	HEXAGON HEAD SCREW FE/ZNXC3	SECHSKANTSCHRAUBE FE/ZNXC3	VITE TESTA ESAGONALE FE/ZNXC3	[1]
008	80061652	002	VIS TETE HEXAGONALE FE/ZNXC3	HEXAGON HEAD SCREW FE/ZNXC3	SECHSKANTSCHRAUBE FE/ZNXC3	VITE TESTA ESAGONALE FE/ZNXC3	[1]
009	80200840	008	ECROU HEX.BAS AUTOFR.FE/ZNXC3	SELF-LOCKING NUT FE/ZNXC3	SELBSTSICHERND.MUTTER FE/ZNXC3	DADO AUTOBLOCCANTE FE/ZNXC3	[1]
010	80201040	008	ECROU HEX.BAS AUTOFR.FE/ZNXC3	SELF LOCKING NUT FE/ZNXC3	SELBSTSICHERND.MUTTER FE/ZNXC3	DADO AUTOBLOCCANTE FE/ZNXC3	[1]
011	80201230	003	ECROU HEX.AUTOFREINE FE/ZNXC3	SELF-LOCKING NUT FE/ZNXC3	SELBSTSICH.MUTTER FE/ZNXC3	DADO AUTOBLOCCANTE FE/ZNXC3	[1]
012	80251176	008	RONDELLE PLATE FE/ZNXC3	PLAIN WASHER FE/ZNXC3	SCHEIBE FE/ZNXC3	RONDELLA PIATTA FE/ZNXC3	[1]
013	80251225	003	RONDELLE PLATE FE/ZNXC3	PLAIN WASHER FE/ZNXC3	SCHEIBE FE/ZNXC3	RONDELLA PIATTA FE/ZNXC3	[1]
014	1036530	001	COLL.TOLES ANDAIN GMD2820F	SWATHBOARD SET	SCHWADBLECH SATZ GMD2820F	KIT ANDANE	OPT +[1]
015	K6804130	001	PATTE	BRACKET	BEFESTIGUNGSEISEN	FAZZOLETTO	[1]
016	K6804140	001	PATTE	BRACKET	BEFESTIGUNGSEISEN	FAZZOLETTO	[1]
017	K7024180	001	TOLE	SHEET	BLECH	TELA	[1]
018	K7024190	001	TOLE	SHEET	BLECH	TELA	[1]
019	K7024200	002	CONTRE-PLAQUE	PLATE, BACKER	BEFESTIGUNGSPLATTE	PIASTRINA	[1]
020	K7024290	002	BAVETTE	FLAP	SCHUTZLAPPEN	PARASPRUZZI	[1]
021	K7024310	001	PLAT	FLAT	FLACHEISEN	PIATTO	[1]
022	K7024320	001	PLAT	FLAT	FLACHEISEN	PIATTO	[1]
023	K7024330	001	DEFLECTEUR	DEFLECTOR	ABWEISER	DEFLETTORE	[1]
024	KE0201TL	001	NOTICE D'EQUIP.COLL.1036530	OPTIONAL EQUIPMENT MANUAL	ANLEITUNG FÜR SONDERAUSRÜSTUNG	MANUALE EQUIPAGGIAMENTI OPZ.	[1]

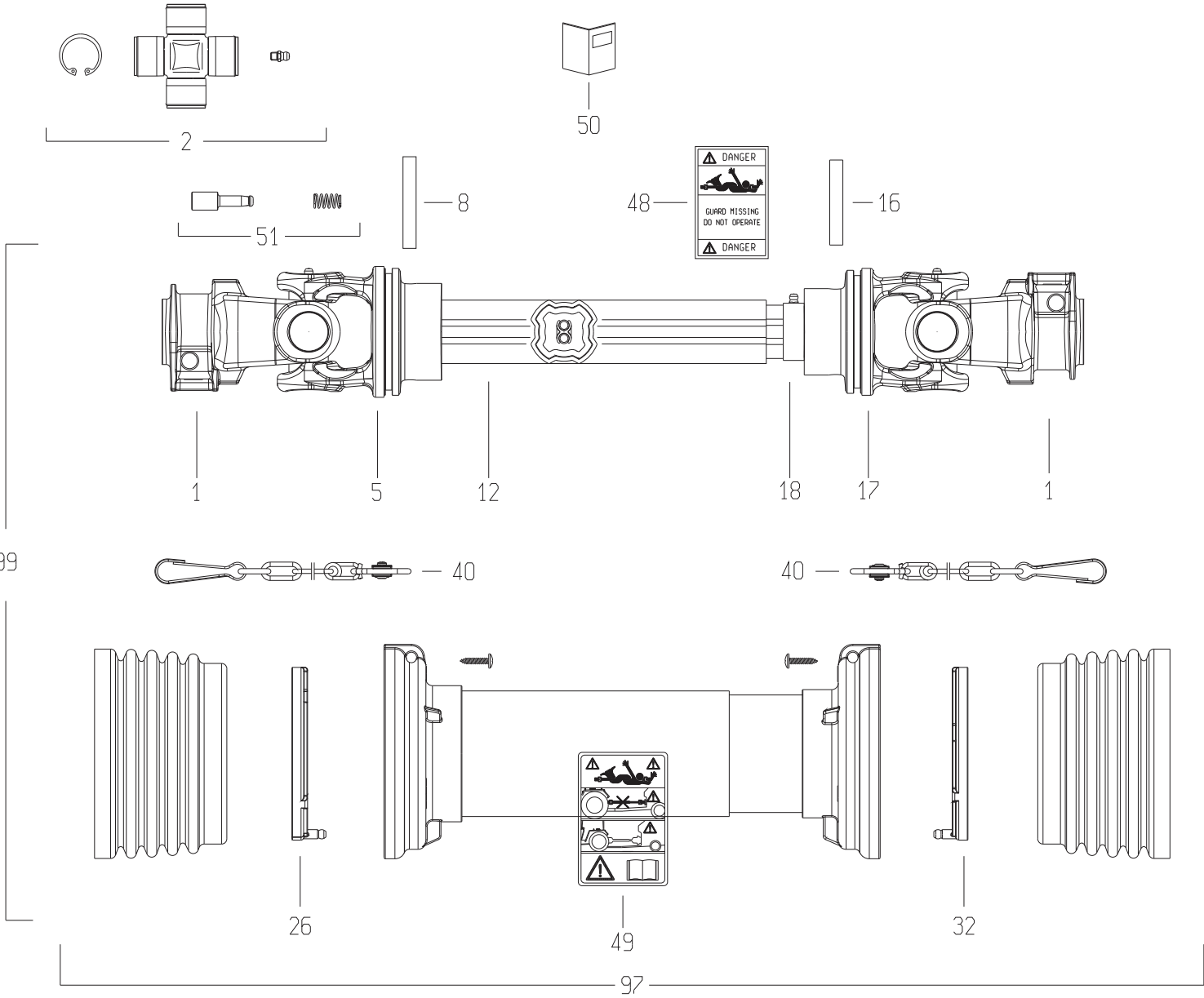



GMD2820F 1000
GMD2820F 540

B 0001 > C 0000
B 0001 > C 0000

K99R0437 C

TRANSMISSION 4800618

TRANSMISSION 4800618

GELENKWELLE 4800618

TRANSMISSIONE 4800618

Rep	Nr	Qt	Designation	Description	Bezeichnung	Referenza	Remarque - Remark - Bemerkung - Osservazioni
001	4803056	002	MACHOIRE	YOKE	RILLEGABEL	FORCELLA	
002	4805078	002	CROISILLON CPL	CROSS JOURNAL	KREUZGARNITUR	CROCIERA	
005	4803012	001	MACHOIRE TUBE EXTERIEUR	YOKE OUTER TUBE	RILLEGABEL AUSSENROHR	FORCELLA	
008	80451059	001	GOUPILLE ELASTIQUE FLZNNC	ROLL PIN FLZNNC	SPANNHUELSE FLZNNC	SPINA ELASTICA FLZNNC	
012	4808133	001	TUBE PROFILE EXTERIEUR	PROFILE TUBE	PROFILROHR	PROFILATO	
016	80451057	001	GOUPILLE ELASTIQUE FLZNNC	ROLL PIN FLZNNC	SPANNHUELSE FLZNNC	SPINA ELASTICA FLZNNC	
017	4803013	001	MACHOIRE TUBE INTERIEUR	YOKE INNER TUBE	RILLEGABEL INNENROHR	FORCELLA	
018	4808136	001	TUBE PROFILE INTERIEUR	PROFILE TUBE	PROFILROHR	PROFILATO	
026	4820100	001	PALIER	SLIDING RING	GLEITRING	SUPPORTO	
032	4820101	001	PALIER	SLIDING RING	GLEITRING	SUPPORTO	
040	4821024	002	CHAINETTE	CHAIN	HALTEKETTE	CATENELLA	
048	A7926009	001	ETIQUETTES	STICKER	AUFKLEBER	ADESIVO	
049	4831002	001	PICTOGRAMME	PICTORIAL	PIKTOGRAMM	ADESIVO	
050	4831003	001	COLL.PICTOGRAMMES ET NOTICE	SET PICTORIALS & INSTRUCTIONS	SATZ PIKTOGRAMME UND ANLEITUNG	SERIE ADESIVI E NOTIZIE	
051	40330050	002	POUSSOIR CPLT	PUSH BUTTON CPLT	SCHIEBESTIEFT KPLT	PULSANTE	
097	4819647	001	PROTECTEUR COMPLET	GUARD COMPLET	SCHUTZ KOMPLET	PROTEZIONE	
099	4800618	001	TRAN.SFTS6 1 3/8-6 610	PTO-S.SFTS6 1 3/8-6 610	GELEN.SFTS6 1 3/8-6 610	CARDA.SFTS6 1 3/8-6 610	



INDEX NUMERIQUE - NUMERICAL INDEX

TEILENUMMERN-INDEX - INDICE NUMERICO

Nr	Page	Rep.	Nr	Page	Rep.	Nr	Page	Rep.	Nr	Page	Rep.	Nr	Page	Rep.	Nr	Page	Rep.	Nr	Page	Rep.	Nr	Page	Rep.
A7160104	035	004	K7008290	019	015	K7019088	027	001	09905510	027	006	50068500	013	001	56212300	011	004	80061020	039	004	80200851	015	019
A7250406	015	036	K7015890	037	005	K7019090	025	001	09914900	025	009	50068900	045	002	56548700	009	006	80061020	041	002	80200851	021	020
A7250406	021	037	K7017031	005	029	K7019097	025	001	09915000	025	010	50070300	015	002	56617500	031	002	80061026	041	001	80200855	015	020
A7260032	015	037	K7017031	007	029	K7019098	025	001	09915100	027	008	50070300	021	004	56630200	009	008	80061073	039	005	80200855	021	021
A7260032	021	038	K7017041	005	030	K7019570	033	018	09915200	027	009	50070300	045	003	56655030	009	009	80061249	015	008	80201030	009	015
A7926009	047	048	K7017041	007	030	K7019690	043	005	1016410	041	008	50070800	045	004	56658410	007	009	80061249	019	007	80201040	015	021
KE0075TL	031	010	K7017231	003	021	K7019700	043	006	1036370	031	001	50072200	015	003	56658510	005	010	80061249	021	010	80201040	019	009
KE0076TL	033	019	K7017240	015	039	K7019770	023	052	1036380	033	001	50072200	021	005	56658600	005	011	80061271	031	004	80201040	021	022
KE0077TL	039	027	K7017261	003	022	K7019780	015	044	1036390	037	004	50073910	011	001	56658600	007	010	80061296	015	009	80201040	039	009
KE0099TL	041	011	K7017310	031	009	K7019780	023	053	1036410	039	001	50074000	011	002	56658700	007	011	80061296	021	011	80201040	041	003
KE0112TL	037	009	K7017321	005	031	K7019980	039	023	1036430	043	001	50080200	029	002	56676800	039	003	80061637	015	010	80201040	045	010
KE0117TL	043	007	K7017331	007	031	K7020050	011	027	1036530	045	014	50086900	013	002	56696400	003	002	80061646	003	008	80201053	039	010
KE0135TL	035	007	K7017432	033	017	K7020211	023	054	1276870	035	001	51504100	033	002	56803420	013	006	80061646	015	011	80201055	013	010
KE0201TL	045	024	K7017450	021	040	K7020221	015	045	40330050	047	051	52234410	033	003	56806510	009	010	80061646	021	012	80201230	045	011
KN154B	029	011	K7017631	015	040	K7020230	015	046	4800618	047	099	52239100	005	006	56806610	013	007	80061646	043	002	80201240	015	022
K1602060	033	014	K7017631	021	041	K7020230	023	055	4803012	047	005	52239100	007	006	56807100	013	008	80061647	045	007	80201240	021	023
K1620620	033	015	K7017751	019	016	K7020330	039	024	4803013	047	017	52253200	033	004	56856700	009	011	80061651	033	006	80201248	011	006
K1631170	033	016	K7017781	019	017	K7020340	039	025	4803056	047	001	52505800	005	007	57522400	003	003	80061652	045	008	80201248	019	010
K3101420	035	005	K7017791	019	018	K7020441	015	047	4805078	047	002	52505800	007	007	57556310	031	003	80061657	003	009	80201262	013	011
K5606630	003	020	K7017840	015	041	K7020441	023	056	4808133	047	012	52545100	005	008	58532000	033	005	80061681	003	007	80201262	029	006
K5700940	015	038	K7017840	021	042	K7020730	023	057	4808136	047	018	53005900	015	033	58733700	003	004	80061683	015	012	80201271	031	006
K5700940	021	039	K7017872	019	019	K7020741	015	048	4819647	047	097	53005900	021	034	58814900	035	002	80061683	021	013	80201448	011	007
K6000030	011	016	K7017882	019	020	K7020750	039	026	4820100	047	026	55729010	003	001	59402900	003	005	80080636	039	006	80201630	003	013
K6000090	013	013	K7018171	021	043	K7021770	019	022	4820101	047	032	55734700	015	004	59900000	025	011	80080660	015	013	80201630	033	007
K6800071	011	017	K7018201	015	042	K7021930	003	025	4821024	047	040	55734700	019	003	59900000	027	010	80080660	021	014	80201630	043	003
K6800080	011	018	K7018201	021	044	K7022100	019	023	4831002	047	049	55734700	021	006	59900200	025	012	80080805	015	014	80201640	003	014
K6800090	011	019	K7018490	021	045	K7022580	037	006	4831003	047	050	55741300	019	004	59900200	027	011	80080805	021	015	80201640	015	023
K6800123	011	020	K7018500	021	046	K7022590	035	006	50002100	005	001	55745700	009	003	59900300	025	013	80081065	009	013	80201640	021	024
K6800671	011	021	K7018540	009	039	K7023260	017	049	50002100	007	001	55749800	015	005	59900300	027	012	80100625	015	015	80201647	015	024
K6800681	011	022	K7018550	009	040	K7023260	023	058	50002100	009	001	55749800	021	007	59900400	025	014	80100625	021	016	80201662	015	025
K6800710	013	014	K7018561	009	041	K7024180	045	017	50002200	015	001	55764900	005	009	59900400	027	013	80111243	031	005	80201662	021	025
K6800780	011	023	K7018830	003	023	K7024190	045	018	50002200	021	001	55764900	007	008	59900800	025	015	80130812	015	016	80250006	003	015
K6800851	011	024	K7018841	003	024	K7024200	045	019	50002200	039	002	55764900	009	007	59900800	027	014	80130812	021	017	599050613	015	026
K6800952	013	015	K7018912	021	047	K7024290	045	020	50003200	019	001	55903210	013	003	59901100	025	016	80131017	013	009	80250613	021	026
K6800962	013	016	K7018922	017	050	K7024310	045	021	50003200	045	001	55903210	029	003	59901100	027	015	80131018	003	010	80250934	015	027
K6801020	011	025	K7018922	021	048	K7024320	045	022	50003600	021	002	55903310	013	004	59901200	025	017	80131225	003	011	80250934	021	027
K6801030	011	026	K7018961	017	051	K7024330	045	023	50005700	021	003	55903310	029	004	59901200	027	016	80190425	009	014	80250934	039	011
K6801520	041	009	K7018961	023	049	K7024810	037	007	50006200	009	002	56009200	009	004	59910300	025	018	80200630	015	017	80250970	015	028
K6801540	041	010	K7018970	017	052	K7024830	037	008	50006600	021	033	56012810	045	005	59910300	027	017	80200630	021	018	80250970	021	028
K6804130	045	015	K7018970	023	050	K9501581	025	002	50018800	005	002	56012900	045	006	80031230	011	005	80200630	039	007	80251176	019	011
K6804140	045	016	K7018980	017	053	K9501581	027	002	50018800	007	002	56115800	013	005	80060630	015	007	80200840	003	012	80251176	039	012
K6804290	013	017	K7018980	023	051	K9501810	025	004	50018900	005	003	56115800	029	005	80060630	021	009	80200840	015	018	80251176	041	004
K6804300	013	018	K7018992	015	043	K9501810	027	004	50018900	007	003	56145200	009	005	80060816	003	006	80200840	019	008	80251176	045	012
K7003170	009	037	K7019000	019	021	K9530020	025	005	50019000	005	004	56202300	015	006	80060820	019	005	80200840	021	019	80251225	045	013
K7003460	031	008	K7019080	027	001	K9530020	027	005	50019000	007	004	56202300	021	008	80060826	009	012	80200840	039	008	80251331	015	029
K7006731	009	038	K7019087	027	001	09905510	025	006	50067100	019	002	56207000	011	003	80061020	019	006	80200840	045	009	80251331	019	012



INDEX NUMERIQUE - NUMERICAL INDEX TEILENUMMERN-INDEX - INDICE NUMERICO

Nr	Page	Rep.	Nr	Page	Rep.	Nr	Page	Rep.	Nr	Page	Rep.	Nr	Page	Rep.	Nr	Page	Rep.	Nr	Page	Rep.
80251331	021	029	81003572	009	028	83090198	015	034												
80251632	015	030	81004080	005	018	83090198	015	035												
80251632	021	030	81004080	007	018	83090198	021	035												
80252046	003	016	81004082	005	019	83090198	021	036												
80254040	005	012	81004082	007	019	83200801	039	017												
80254040	007	012	81004090	009	029	83240010	039	018												
80254041	005	013	81004585	009	030	83240011	039	019												
80254041	007	013	81005091	009	031	83240014	003	019												
80254042	005	014	81104580	011	009	83240014	041	005												
80254042	007	014	81104581	011	010	83240202	039	020												
80254043	005	015	81304079	005	020	83240209	041	006												
80254043	007	015	81304079	007	020	83240210	041	007												
80255670	009	016	81304590	005	021	83240404	039	021												
80255671	009	017	81304590	007	021	83240405	039	022												
80255677	009	018	82013572	009	032	83450005	029	007												
80256565	009	019	82014081	005	022	83503018	029	008												
80256566	009	020	82014081	007	022	83503019	029	009												
80257055	005	005	82014580	005	023	83503026	029	010												
80257055	007	005	82014580	007	023	9006600	029	001												
80257070	009	021	82016090	009	033															
80257078	009	022	82060046	011	011															
80280820	009	023	82060050	009	034															
80281230	021	031	82060052	005	024															
80281254	011	015	82060052	007	024															
80281254	013	012	82062226	011	012															
80281414	011	008	82064550	011	013															
80281639	003	017	82101622	005	025															
80281639	015	031	82101622	007	025															
80281639	021	032	82101622	011	014															
80281639	043	004	82131824	005	026															
80451057	047	016	82131824	007	026															
80451059	047	008	82131824	009	035															
80451246	033	008	82230003	005	027															
80500445	033	009	82230003	007	027															
80500565	033	010	82230003	009	036															
80510460	035	003	82230006	005	028															
80560440	019	013	82230006	007	028															
80561155	033	011	83019908	003	018															
80561155	037	001	83030011	039	013															
80570500	037	002	83040205	015	032															
80584000	005	016	83070056	037	003															
80584000	007	016	83070061	019	014															
80585200	009	024	83070063	033	012															
80597200	009	025	83070063	033	013															
80598000	005	017	83070064	031	007															
80598000	007	017	83090037	039	014															
80599000	009	026	83090038	039	015															
80651031	009	027	83090039	039	016															

EXTRAIT DES CONDITIONS DE GARANTIE ET CONDITIONS SPECIFIQUES PIECES DE RECHANGE

Nous garantissons notre matériel durant une année à partir du jour de livraison, c'est-à-dire que nous nous engageons à rembourser les pièces qui auront été reconnues défectueuses en nos usines, par notre service technique.

Bien entendu, la garantie ne s'applique pas en cas d'usure normale, ni en cas de détériorations résultant de négligences ou de défauts de surveillance, d'un mauvais usage, d'un manque d'entretien ou d'un accident. La garantie ne s'applique pas non plus si la machine a été prêtée ou utilisée pour un usage non conforme à sa destination prévue par la société.

La garantie ne s'applique pas aux pièces d'usure.

Les pièces de rechange sont soumises aux mêmes conditions de garantie que le matériel sous réserve qu'elles aient été montées selon les règles de l'art et utilisées conformément à nos recommandations.

EXTRACT FROM OUR CONDITIONS OF LIMITED WARRANTY AND SPARE PARTS WARRANTY POLICY

Our equipment is warranted for a period of one year from the date of delivery. We guarantee the reimbursement of all parts proven to be faulty by our technical division in material or manufacturing.

The warranty is not applicable in the following cases : normal wear, accident or negligence in operation, repairs using parts other than genuine KUHN parts, products altered or modified without the expressed permission of the company or if the machine is not used and serviced in accordance with the recommendations of the operator's manual. Wearing items are not covered under these conditions of limited warranty.

Spare parts are subject to the same warranty conditions than the equipment providing they have been installed with proficiency and are used in accordance with our recommendations.

AUSZUG AUS UNSEREN GARANTIEBEDINGUNGEN UND SONDERBEDINGUNGEN FÜR ERSATZTEILE

Wir garantieren unsere Ware für ein Jahr ab dem Tag der Lieferung und verpflichten uns, die Teile zu ersetzen, die im Werk als fehlerhaft anerkannt wurden.

Die Garantie ist ausgeschlossen für Teile, die einem normalen Verschleiß unterliegen, sowie im Fall von nachlässiger Behandlung oder mangelhafter Wartung oder eines Unfalls. Die Garantie erlischt auch, wenn die Maschine ausgeliehen oder unter Umständen eingesetzt wurde, die dem ursprünglichen Verwendungszweck und den Hinweisen in der Betriebsanleitung nicht entsprechen.

Verschleißteile sind von der Garantie ausgeschlossen

Ersatzteile unterliegen den gleichen Garantiebedingungen wie komplette Maschinen, vorausgesetzt, dass sie sachgerecht eingebaut und entsprechend unseren Empfehlungen verwendet wurden.

ESTRATTO DELLE CONDIZIONI DI GARANZIA E CONDIZIONI SPECIFICHE GARANZIA RICAMBI

Le nostre macchine sono garantite per un anno a partire dal giorno della consegna: ci impegnamo a rimborsare i componenti che saranno riconosciuti difettosi dai nostri servizi tecnici presso le nostre officine.

La garanzia non è applicabile nei seguenti casi: usura normale, incidente o negligenza nell'impiego, riparazioni utilizzando ricambi non originali KUHN, prodotti alterati o modificati senza il permesso dell'azienda. La garanzia non viene riconosciuta se la macchina è stata prestata o non è utilizzata o mantenuta in conformità alle raccomandazioni previste dalla società. La garanzia non copre i componenti soggetti ad usura.

I pezzi di ricambio sono soggetti agli stessi termini di garanzia della macchina, purchè siano stati installati con competenza e utilizzati conformemente alle nostre raccomandazioni.



**Pour votre sécurité et le bon fonctionnement de votre machine,
utilisez uniquement des pièces d'origine KUHN**

**For your safety and to get the best from your machine,
use only genuine KUHN parts**

**Zu ihrer Sicherheit und zur einwandfreien Funktion Ihrer
Maschine sollten Sie nur Original-KUHN-Ersatzteile verwenden**

**Per la vostra sicurezza, e per il buon funzionamento della vostra macchina,
usate esclusivamente i ricambi originali KUHN**

**KUHN PARTS Parc de la Faisanderie F - 67700 MONSWILLER (FRANCE)
www.kuhn.com**

Imprimé en France par KUHN
Printed in France by KUHN