

SM 2805



B01

Valid from: | Gültig ab:
Valable á partir de: | Gyldig fra:
15.09.2017

Serial No.: | Maschinen Nr.:
No. de serie: | Fabrikationsnr.:
B027140181148

You can always find the latest
version of the Spare Parts List at
www.kongskilde.com

Reservedelsliste
Spare parts list
Ersatzteilliste
Liste de pièce de rechange

Always state the serial number and if possible the year of the machine when ordering spare parts whereby you save time and money and facilitates matters for us.
Please enter the number of your machine here:

No..... Delivered on the / 20.....
Appropriate when ordering parts.
The serial number is located as shown on the figure.

Bei Ersatzteilbestellungen ist die Fabrikationsnummer Ihrer Maschine unbedingt anzugeben.
Das erspart Ihnen Zeit, Geld und Ärger und erleichtert uns die Abfertigung.
Tragen Sie die Nummer Ihrer Maschine bitte hier ein:

Nr..... Geliefert am / 20.....
dann haben Sie bei Ersatzteilbestellungen immer die Nummer bei der Hand.
Die Fabrikationsnummer ist im Rahmen eingeschlagen, siehe Figur.

Lorsque vous commandez des pièces détachées, indiquez toujours le numéro de série de votre machine et si possible son année de fabrication. Vous éviterez des pertes de temps et vous nous faciliterez le travail.
Prière de noter ici le numéro de série de votre machine:

Numéro..... Livrée le / 20.....

Ceci vous sera utile lorsque vous commanderez des pièces.
Le numéro de série est gravé dans le cadre comme indiqué sur la figure.

Bestiller De reservedele så opgiv venligst maskinens fabrikationsnummer og eventuelt købsår. Det sparer Dem tid, penge og ærgrelser og os unødigt besvær.
De kan notere nummeret på Deres maskine her:

Nr..... Leveret den / 20.....
så har De det ved hånden, når De eventuelt skal bestille reservedele.
Fabrikationsnummeret findes indhugget i rammen, som vist på figuren.

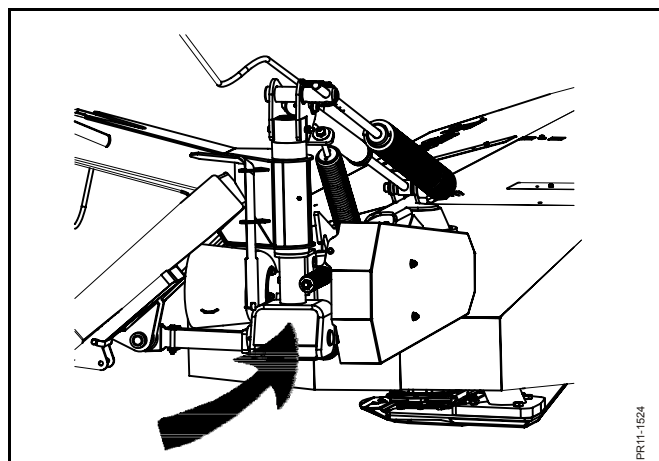

SPARE PARTS BOOK ERSATZTEILKATALOG CATALOGUE DE PIÈCES RESERVEDELSKATALOG

The book is divided into 5 passages:

1. Description of the spare part book.
2. Number key for assembly parts.
3. Number key showing on which figures the spare part numbers can be found.
4. Figure key showing on which figures the parts can be found.
5. Spare parts list.

Der Katalog ist in 5 Abschnitte eingeteilt:

1. Beschreibung des Ersatzteilkataloges.
2. Nummernschlüssel für Montagezubehör.
3. Nummernschlüssel mit Angabe der jeweiligen Ersatzteilnummer.
4. Figurliste mit Angabe, auf welche Figuren die Teile zu finden sind.
5. Ersatzteilliste.

Le catalogue est divisé en 5 sections:

1. Description du catalogue de pièces.
2. Liste de pièces de montage.
3. Numéros des pièces de rechange indiquant le numéro de figure.
4. Liste des figures indiquant sur quelle figure se trouvent les pièces.
5. Liste de pièces de rechange.

Kataloget er opdelt i 5 afsnit:

1. Beskrivelse af reservedelskataloget.
2. Nummernøgle for monteringsdele.
3. Nummernøgle - viser på hvilke figurer reservedelsnumrene findes.
4. Figurnøgle - viser på hvilke figurer delene findes.
5. Reservedelsliste.

**Description of the spare parts book:
Beschreibung des Ersatzteilkataloges:
Discription du catalogue de pièces:
Beskrivelse af reservedelskataloget:**

The spare parts book is built up as follows:

Fig. 01-29 Standard Fig. 50-59 Hub
Fig. 30-39 Gear Fig. 60-79 Variation of standard (Accessory)
Fig. 40-49 PTO drives Fig. 80- Accessory

Der Ersatzkatalog ist so aufgebaut:

Fig. 01-29 Standard Fig. 50-59 Nabe
Fig. 30-39 Getriebe Fig. 60-79 Variation vom Standard (Zubehör)
Fig. 40-49 Gelenkwellen Fig. 80- Zubehör

Le catalogue de pièces est arrangé comme suit:

Fig. 01-29 Standard Fig. 50-59 Moyeu
Fig. 30-39 Boîtier Fig. 60-79 Variation du standard (Accessoire)
Fig. 40-49 Arbres à cardan Fig. 80- Accessoire

Reservedelskataloget er opbygget således:

Fig. 01-29 Standard Fig. 50-59 Nav
Fig. 30-39 Gear Fig. 60-79 Variation af standard (Tilbehør)
Fig. 40-49 Kraftoverføringsaksler Fig. 80- Tilbehør

Quantity:

States quantity of parts for machine.
In connection with subassemblies:
Quantity for the assembly.

Anzahl:

Anzahl Teile je Maschine.
Bei Untersammlungen:
Anzahl je Sammlung.

Quantité:

Quantité de pièces par machine.
Pour les sous-assemblages: pièces
par assemblage.

Antal:

Antal dele pr. maskine.
Ved undersamlinger: dele pr. samling.

Position No.:

The position No. marked “()”
is not standard.
Is delivered as accessory.

Positionsnummer:

Die Positionsnummer, die mit “()”
gezeichnet ist, ist nicht der Standard.
Wird als Zubehör geliefert.

No de pos.:

Le numéro de position marqué d’un “()”
n’est pas une pièce standard.
Livrée comme accessoire.

Pos. nr.:

Positionsnummer mærket med “()”
er ikke standard.
Leveres som tilbehør

POS.	VARENUMMER	ANTAL	BENÆVNELSE	BEZEICHNUNG	DESIGNATION	HERTIL, DAZU TO THIS, A CECI
33.	1340-9153 T	2	KRYDS KREUTZGARNITUR >=0003219 <=0003448	CENTRE		1341-9187 1
33.1	1350-7005	2	KRYDS KREUTZGARNITUR >=0003219	CENTRE		1350-9052 4 1350-9104 1
34.	1340-0196	1	PROFILAKSEL PROFILGABEL >=0003219 <=0003448	PROFIL FORK		
34.1	1350-8008	1	PROFILAKSEL PROFILGABEL >=0003249	PROFIL FORK		

Article no.:

The article no. marked “T” is not
standard. Is delivered as accessories.
The article no. marked “+”:
Modification is being made.

Warennummer:

Ist eine Warennummer mit “T” ge-
kennzeichnet, wird sie als Zubehör
geliefert.
Eine Warennummer mit “+” ist als
Modifikation unterwegs.

No. D’article:

Le no d’article marqué d’un “T” n’est pas
un article standard. Livré comme
accessoire.
No. d’article marqué de “+”:
Une modification viendra.

Varenr.:

Varennummer mærket med “T” er ikke
standard. Leveres som tilbehør.
Varennummer mærket med “+”:
ændring undervejs.

Designation:

>=0003219 <=0003448
Spare part used for machine from
serial No. 3219 up to No. 3448 both
Nos. included.

Benennung:

>=0003219 <=0003448
Ersatzteil für Maschinen von
Fabrikationsnummer 3219 bis
Nr. 3448.

Désignation:

>=0003219 <=0003448
Pièce de rechange employée sur
machines à partir de no de série 3219
jusq’à et y compris no 3448.

Benævnelser:

>=0003219 <=0003448
Reservedel anvendt på maskine fra og
med fabrikationsnummer 3219 til
og med nr. 3448

To this:

States which and how many mounting
parts (screws, nuts, discs etc.)
are used with the spare part.
See under number key for assembly parts

Dazu:

Angabe von Montierungsteilen
(Schrauben, Muttern, Scheiben usw.)
die zusammen mit dem Ersatzteil
angewendet werden sollen. Siehe
Nummerschlüssel
für Montagezubehör.

Pour ceci:

Indique lesquelles et combien de
pièces de montage (vis, écrous, rondelles
etc.) sont employées avec la pièce de
rechange. Voir dans la liste de numéros
pour pièces de montage.

Hertil:

Angiver hvilke og hvor mange
monteringsdele (skruer, møtrikker, skiver
osv.) der anvendes sammen med reserve-
delen. Se under nummernøgle for
monteringsdele.

Acc Part No	Beskrivelse	Bezeichnung	Designation
811165-0158	BESKYTTELSESHETTE NR 71	SCHUTZKAPPE NR 71	PROTECTION NR 71
811213-1126	STÅLSÆTSKRUE M6-16	ST. SETSCHRAUBE M6-16	STEEL SET SCREW M6-16
811213-2222	STÅLSÆTSKRUE M8-20	ST. SETSCHRAUBE M8-20	STEEL SET SCREW M8-20
811213-3222	STÅLSÆTSKRUE M10-20	ST. SETSCHRAUBE M10-20	STEEL SET SCREW M10-20
811213-3224	STÅLSÆTSKRUE M10-25	ST. SETSCHRAUBE M10-25	STEEL SET SCREW M10-25
811213-5424	STÅLSÆTSKRUE M16-45	ST. SETSCHRAUBE M16-45	STEEL SET SCREW M16-45
811213-5522	STÅLSÆTSKRUE M16-50	ST. SETSCHRAUBE M16-50	STEEL SET SCREW M16-50
811213-5622	STÅLS[TSKRUE M16-60	STEEL SET SCREW M16-60	ST. SETSCHRAUBE M16-60
811214-2126	STÅLSKRUE M8-45	STAHLSECHSKANTSCHRAUBE M8-45	STEEL SCREW M8-45
811214-2328	STÅLSÆTSKRUE M8-90 GALV.	STAHLSCHRAUBE M8-90 GALV.	STEEL SET SCREW M8-90 GALV.
811214-3328	STÅLSKRUE M10-90	STAHLSECHSKANTSCHRAUBE M10-90	STEEL SCREW M10-90
811214-4422	STÅLSKRUE M12-100	STAHLSECHSKANTSCHRAUBE M12-100	STEEL SCREW M12-100
811214-5220	STÅLSKRUE M16-60	STAHLSECHSKANTSCHRAUBE M16-60	STEEL SCREW M16-60
811215-3222	BREDEDESKRUE M10-20 H-3	FLACHRUNDSCHRAUBE M10-20 H-3	CARRIAGE SCREW M10-20 H-3
811215-3226	BREDEDESKRUE M10-25 KVAL.8,8	FLACHRUNDSCHRAUBE M10-25 Q 8,8	CARRIAGE SCREW M10-25 Q 8,8
811215-4220	BREDEDESKRUE M12-25 KV. 8.8	FLACHRUNDSCHRAUBE M12-25	CARRIAGE SCREW M12-25 Q. 8.8
811215-4328	BREDEDESKRUE M12-30 KV. 8.8.	FLACHRUNDSCHRAUBE M12-30 Q 8.8	CARRIAGE SCREW M12-30 Q. 8.8
811219-0209	SKRUE M10-25 12,9 DELTA B	SCHRAUBE M10-25 12,9 DELTA B	SCREW M10-25 12,9 DELTA B
811219-0210	SKRUE M10-30 12.9 DELTA B	SCHRAUBE M10-30 12.9 DELTA B	SCREW M10-30 12.9 DELTA B
811219-0245	UNBRACOSKRUE M12-30 MC	INNENSECHSK. SCHR. M12-30 MC	ALLEN SCREW M12-30 MC
811219-0290	SKRUE CH M12-35	SCHRAUBE M12-35	SCREW CH M12-35
811219-0323	UNBRACOSKRUE M10-25 BMTX	INNENSECHSK. SCHR. M10-25	ALLEN SCREW M10-25 BMTX
811219-0599	SELVSKERENDE SKRUE M6-20/M6SF	SCHRAUBE M6-40/M6SF	SCREW M6-40/M6SF
811220-1323	NYLOC MØTRIK M6	NYLOC MUTTER M6	NYLOC NUT M6
811220-2321	NYLOC MØTRIK M8	NYLOC MUTTER M8	NYLOC NUT M8
811220-3321	NYLOC MØTRIK M10	NYLOC MUTTER M10	NYLOC NUT M10
811220-3323	NYLOC MØTRIK M10 KVAL 10.9	NYLOC MUTTER M10 Q. 10.9	NYLOC NUT M10 Q. 10.9
811220-3922	MØTRIK M10	MUTTER M10	NUT M10
811220-4321	NYLOC MØTRIK M12	NYLOC MUTTER M12	NYLOC NUT M12
811220-4323	NYLOC MØTRIK M12 KV 10	NYLOC MUTTER M12 Q 10	NYLOC NUT M12 Q 10
811220-5122	STÅLMØTRIK M16	STAHLMUTTER M16	STEEL NUT M16
811220-5321	NYLOC MØTRIK M16	NYLOC MUTTER M16	NYLOC NUT M16
811241-1201	SPÆNDESKIVE 6,6-12-1,6	SCHEIBE 6,6-12-1,6	WASHER 6,6-12-1,6
811241-1207	SPÆNDESKIVE 6,4-12-1,6	SCHEIBE 6,4-12-1,6	WASHER 6,4-12-1,6
811241-1304	SPÆNDESKIVE 8-22-1,5	SCHEIBE 8-22-1,5	WASHER 8-22-1,5
811241-1403	SPÆNDESKIVE 9-16-2,0	SCHEIBE 9-16-2,0	WASHER 9-16-2,0
811241-1407	SKIVE	SCHEIBE	WASHER
811241-2402	SPÆNDESKIVE 10,5-20-2,0	SCHEIBE 10,5-20-2,0	WASHER 10,5-20-2,0
811241-2502	SPÆNDESKIVE 10,5-22-3	SCHEIBE 10,5-22-3	WASHER 10,5-22-3
811241-3403	SPÆNDESKIVE 13-25-2,5	SCHEIBE 13-25-2,5	WASHER 13-25-2,5
811241-4502	SPÆNDESKIVE 17-30-3 STÅL	SCHEIBE 17-30-3 STAHL	WASHER 17-30-3 STEEL
811241-4604	SPÆNDESKIVE 17-39-4	SCHEIBE 17-39-4	WASHER 17-39-4
811241-6605	SPÆNDESKIVE 26-40-4	SCHEIBE 26-40-4	WASHER 26-40-4
811241-6702	SPÆNDESKIVE 29-42-5	SCHEIBE 29-42-5	WASHER 29-42-5
811241-7802	SPÆNDESKIVE 37-52-6	SCHEIBE 37-52-6	WASHER 37-52-6
811241-9514	STØTTESKIVE 45-56-3.0	STUETZSCHEIBE 45-56-3.0	SUPPORT WASHER 45-56-3.0
811242-3221	FJEDERSKIVE M10	FEDERSCHEIBE M10	SPRING WASHER M10
811251-3202	SPÆNDESTIFT 5-36	SPANNSTIFT 5-36	SPECIAL PIN 5-36
811251-4301	SPÆNDESTIFT 6-40	SPANNSTIFT 6-40	SPECIAL PIN 6-40
811251-5304	SPÆNDESTIFT 8-45	SPANNSTIFT 8-45	SPECIAL PIN 8-45
811251-5403	SPÆNDESTIFT 8-50	SPANNSTIFT 8-50	SPECIAL PIN 8-50
811251-5503	SPÆNDESTIFT 8-60	SPANNSTIFT 8-60	SPECIAL PIN 8-60
811251-5504	SPÆNDESTIFT 8-65	SPANNSTIFT 8-65	SPECIAL PIN 8-65
811251-6601	SPÆNDESTIFT 10-70	SPANNSTIFT 10-70	SPECIAL PIN 10-70
811252-3102	SPLIT 4-25	SPLINT 4-25	COTTER PIN 4-25
811254-4201	SIKRINGSSPLIT 10 MM	FEDERSPLINT 10 MM	SECURING PIN 10 MM
811313-1101	SMØRENIPPEL	SCHMIERNIPPEL	GREASE NIPPLE
811433-0325	LÅSEFJEDER	SCHLOSSFEDER	SPRING

Part number	FigRev.	Pos. Rev.	Part number	Fig. Rev.	Pos.Rev.	Part number	Fig. Rev.	Pos. Rev.
811213-3322	001	037	811213-4724	003	007	811213-5822	001	012
811214-2126	001	009	811214-2326	001	068	811214-3430	001	036
811214-5723	001	072	811214-6822	001	060	811219-0208	004	008
811219-0210	004	003	811219-0220	005	015	811219-0227	004	009
811220-2122	001	010	811220-2321	001	065	811220-3122	002	020
811220-3321	002	017	811220-3920	001	013	811220-4122	001	045
811220-4321	003	009	811220-5321	001	066	811220-6321	001	059
811241-2502	002	021	811241-3403	003	008	811241-4601	001	071
811241-4802	002	011	811241-5504	002	014	811241-6606	001	017
811241-9984	001	075	811251-8901	001	035	811254-3103	001	033
811254-3201	001	041	811255-4102	005	011	811255-4201	002	008
811311-1112	001	055	811311-1419	001	056	811311-2304	001	049
811311-8534	001	028	811311-8538	001	050	811311-8539	001	048
811311-8554	001	073	811313-2101	001	030	811315-0225	030	000
811315-9109	030	008	811315-9140	030	010	811315-9142	030	028
811315-9237	030	029	811315-9274	030	009	811315-9429	030	017
811315-9430	030	014	811315-9670	030	001	811315-9671	004	017
811315-9671	030	002	811315-9672	030	004	811315-9673	030	005
811315-9674	030	007	811315-9675	030	012	811315-9676	030	013
811315-9677	030	015	811315-9678	030	016	811315-9679	030	018
811315-9680	030	019	811315-9681	030	020	811315-9682	030	021
811315-9683	030	022	811315-9684	030	024	811315-9685	030	025
811315-9686	030	026	811315-9687	030	027	811315-9688	030	033
811315-9689	030	034	811315-9690	030	035	811315-9691	030	036
811315-9692	030	039	811315-9874	030	031	811317-0302	001	027
811317-0444	001	029	811317-0734	001	047	811317-0989	001	046
811317-9830	001	074	811331-2303	005	013	811331-3304	002	003
811331-9909	030	011	811335-5502	001	057	811335-5536	001	023
811335-5546	001	034	811338-0105	002	002	811338-0115	030	032
811340-5220	040	000	811340-9022	040	023	811340-9023	040	027
811340-9135	040	013	811340-9212	040	021	811340-9213	040	011
811342-3088	040	004	811342-3089	040	005	811350-0146	006	012
811362-9738	002	012	811380-0046	006	007	811380-0047	006	005
811393-0138	001	032	811393-0174	002	024	811393-0193	001	038
811399-0124	001	077	811399-0128	001	031	811431-5698	001	070
811431-6696	002	026	811432-2299	001	008	811433-0292	001	042
811433-0325	003	003	811434-0107	003	006	811434-0108	004	044
811434-0111	004	054	811501-0107	040	025	811501-0108	040	026
812061-002X	001	011	812081-059X	002	005	812082-020X	002	004
812082-130X	002	001	812082-144X	002	009	812083-706B	001	002
812083-706B	006	013	812085-703X	006	011	812085-704X	006	008
812085-706X	004	041	812085-707X	004	042	812085-708X	004	047
812085-709X	004	043	812085-710X	004	045	812085-711X	004	046
812085-712X	004	048	812085-714X	004	049	812085-715X	004	050
812085-716X	004	051	812085-717X	004	010	812085-718X	004	015
812085-719X	004	011	812085-720X	004	012	812085-721X	004	013
812085-722X	004	020	812085-723X	004	016	812085-724X	004	014
812085-729X	004	007	812085-731X	004	018	812085-733X	004	006
812085-735X	004	019	812085-739X	004	040	812085-750X	004	052
812085-751X	004	053	812088-560X	005	021	812088-566X	005	018
812089-180X	006	009	812223-220X	001	005	812223-267X	001	004
812225-092X	001	079	812225-397X	006	010	812227-193X	003	005
812227-210X	001	067	812227-215X	002	007	812227-224X	002	010
812227-269X	001	062	812227-270X	003	012	812227-329X	001	001
812227-330X	001	018	812227-331X	001	006	812227-332X	001	025
812227-333X	002	013	812227-334X	001	003	812227-335X	001	020
812227-336X	001	019	812227-340X	001	026	812227-341X	001	007
812227-343X	002	015	812227-344X	002	016	812227-345X	002	019
812227-346X	002	018	812227-366X	001	053	812227-386X	001	076
812227-400X	001	043	812227-552X	002	025	812227-693X	001	078
812227-910X	001	044	812227-931X	005	019	812227-932X	005	004
812227-942X	005	023	812227-943X	005	006	812227-954X	001	058
812279-023X	005	014	812279-153X	001	081	812279-221X	005	010
812279-223X	005	012	812363-404X	004	000	813085-705X	004	005
813085-738A	004	004	813085-757X	004	001	813087-449A	006	006
813088-050X	005	009	813088-076X	005	008	813088-526X	005	020
813088-536X	006	003	813088-539X	006	002	813088-541X	006	001
813088-549X	005	002	813088-554A	005	007	813088-564X	005	001
813088-584X	005	024	813089-703X	005	022	813210-436X	006	014
813225-087X	001	080	813225-712X	001	069	813227-217X	001	063
813227-218X	001	064	813227-220X	002	006	813227-225X	001	051

SM-0003/3

Nummernøgle - Nummerschlüssel - Number key - Liste des numeros

Part number	FigRev.	Pos. Rev.	Part number	Fig. Rev.	Pos.Rev.	Part number	Fig. Rev.	Pos. Rev.
813227-227X	001	052	813227-229X	002	022	813227-250X	001	061
813227-266B	001	016	813227-271X	001	022	813227-279X	001	024
813227-284X	003	014	813227-310X	003	013	813227-338X	001	015
813227-347X	001	014	813227-363X	001	039	813227-379X	001	040
813227-690X	003	018	813227-900X	003	015	813227-919X	005	003
813227-939X	005	005	813227-946X	003	016	813227-958B	003	004
813227-983X	003	020	813227-988X	003	022	813227-990X	003	021
813227-992X	003	023	813229-517A	006	004	813279-502X	005	016
813890-117X	001	099						
810602140	001	054	811165-0189	005	017	811213-3225	002	023

Fig. 1

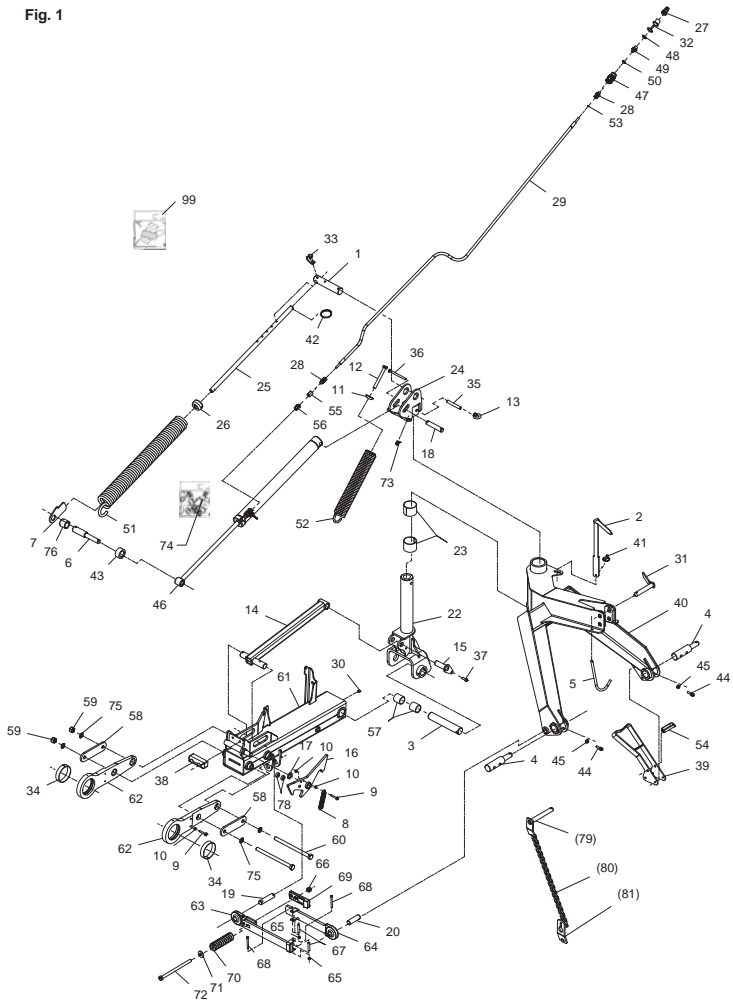

Fig. 2

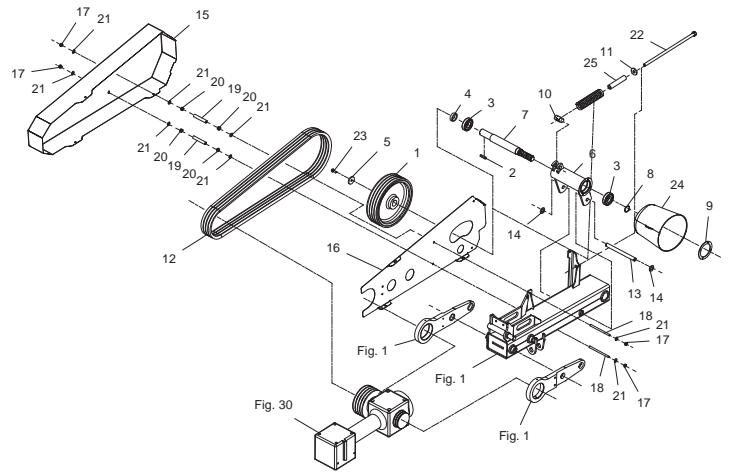

Fig. 3

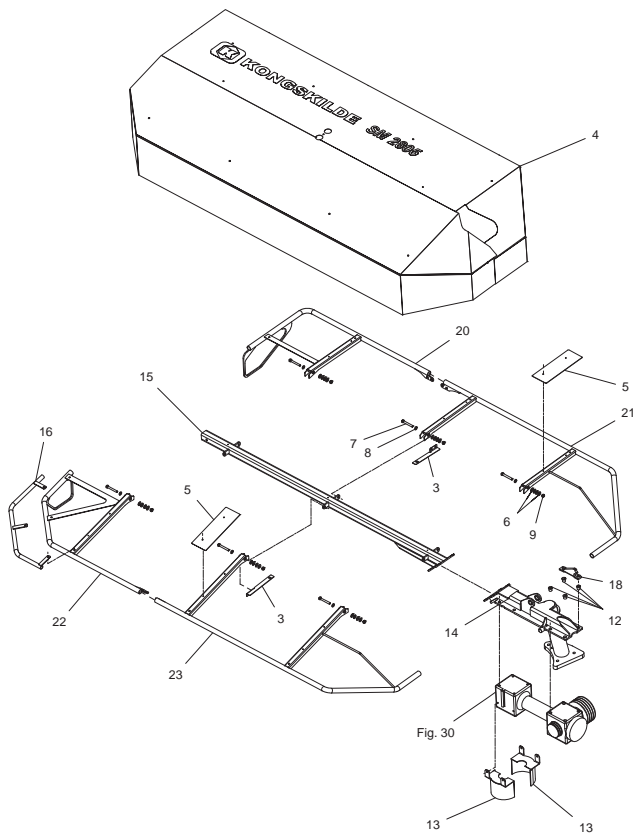

Fig. 4

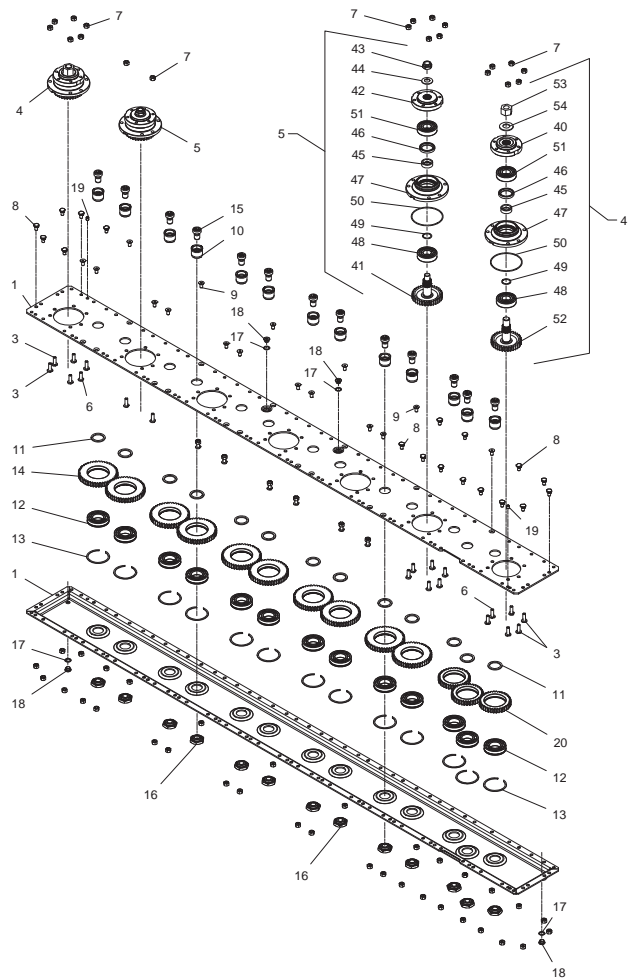

Fig. 5

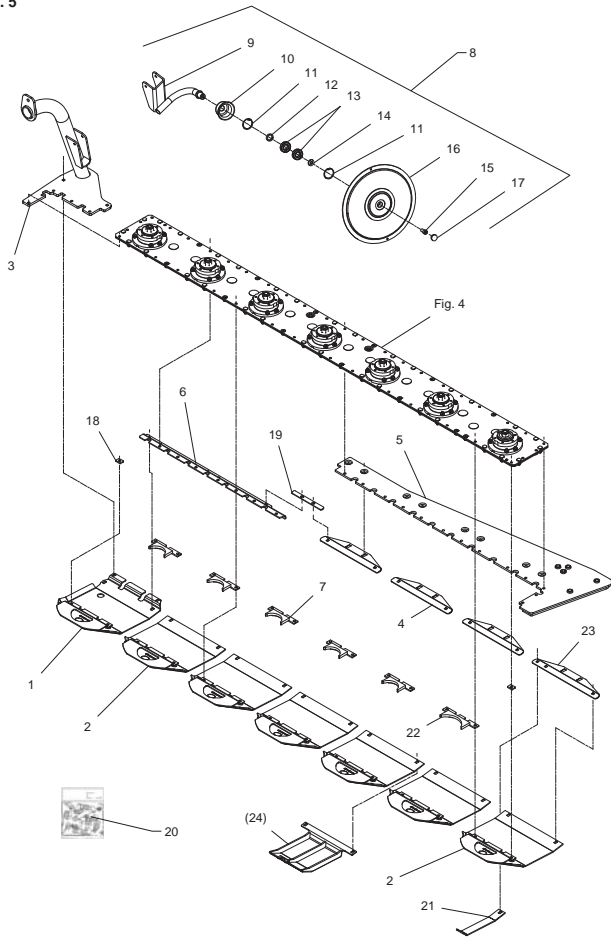

Fig. 6

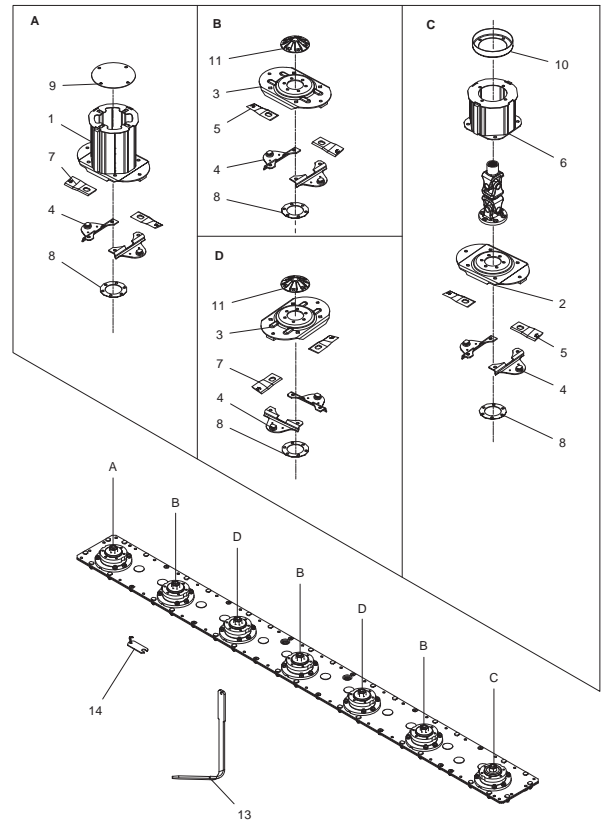

Fig. 30

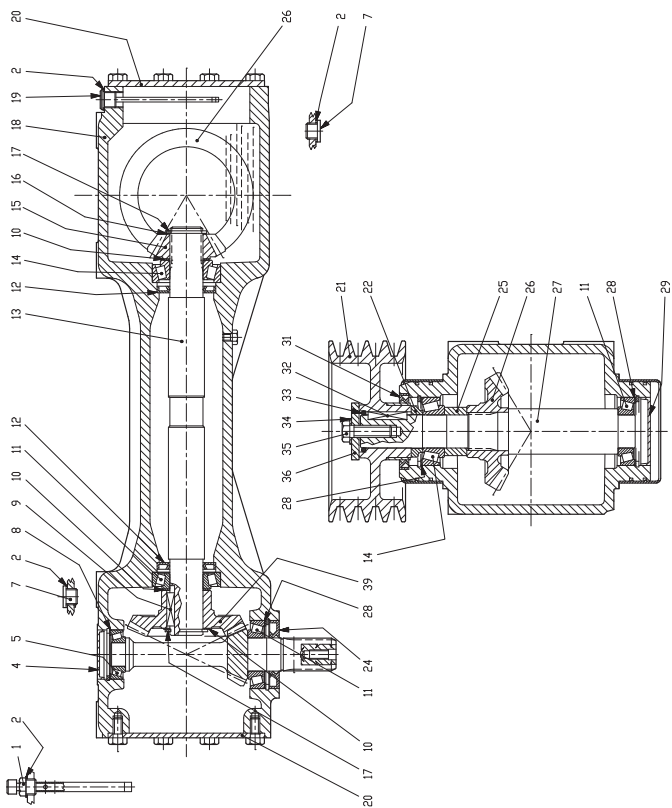

Fig. 40

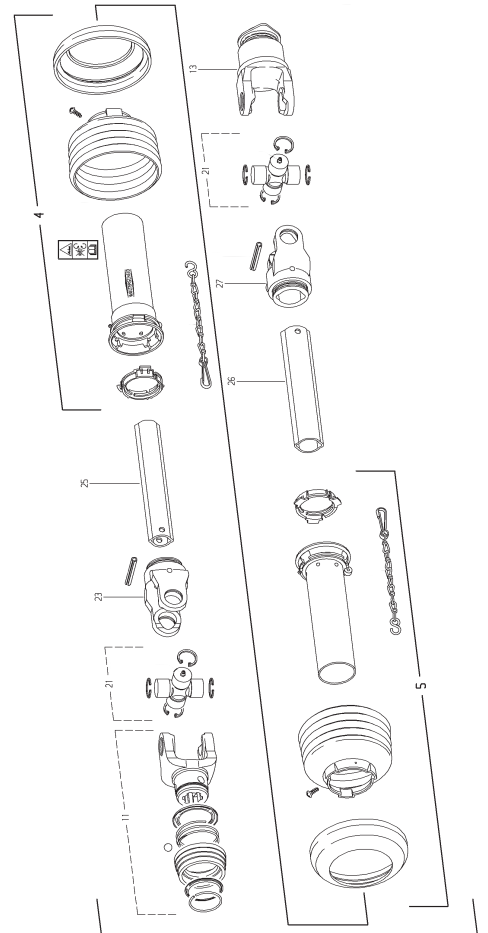
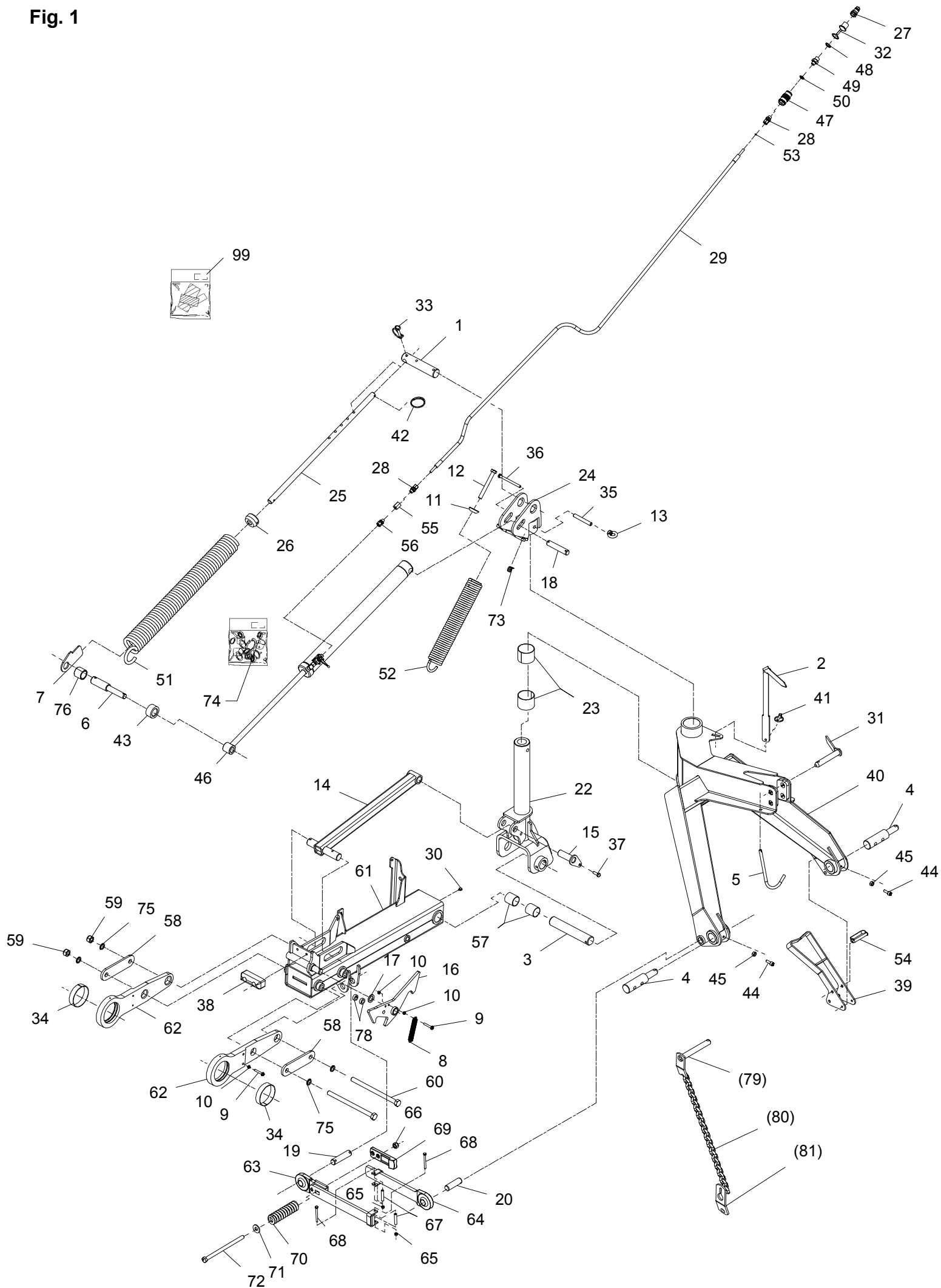
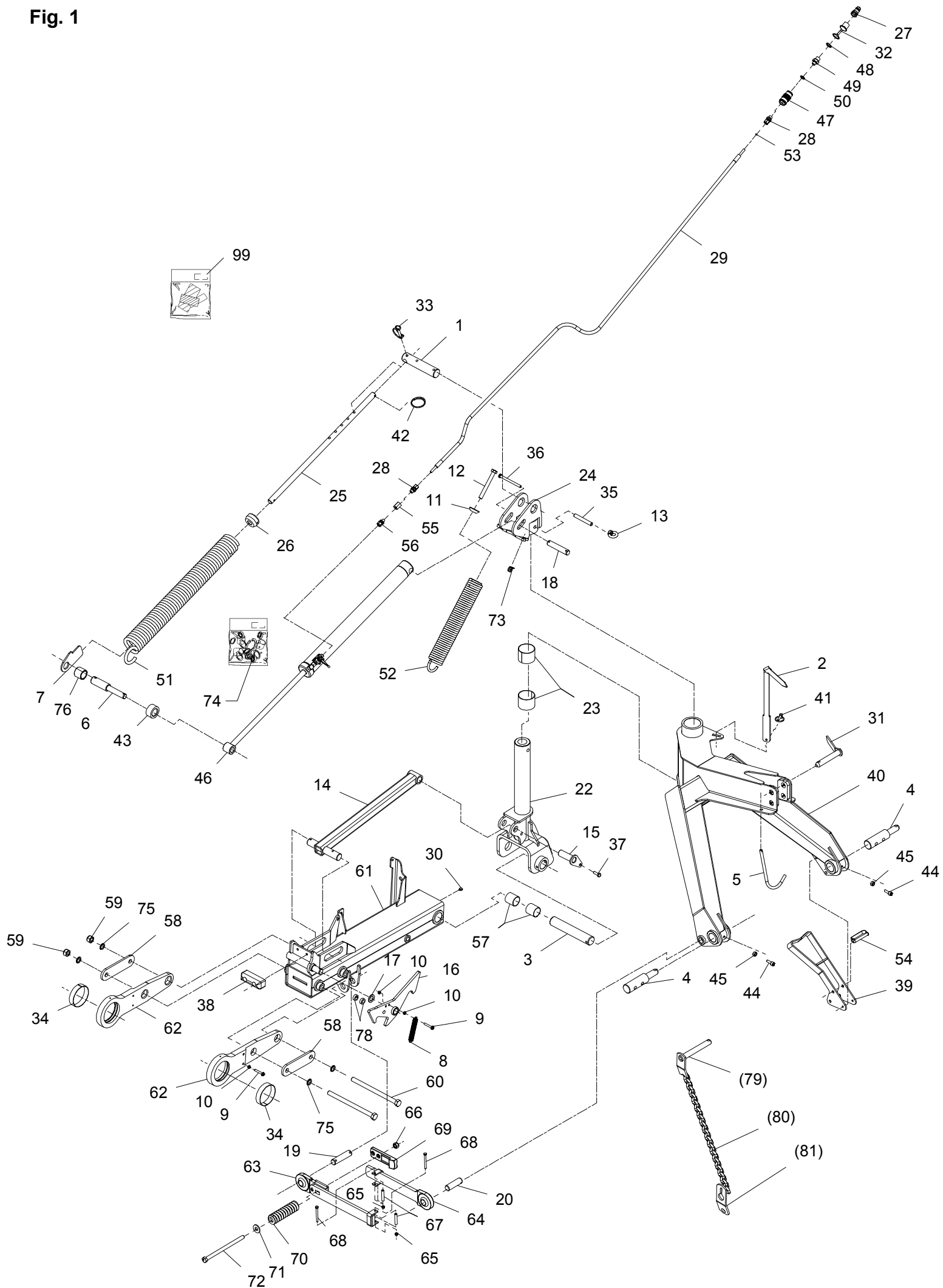

Fig. 1



SM-0003/3		SM 2805		Figure No	001	>=B027140181148	Hertil, Dazu	
								To this, A ceci
Position No	Spare Part No	Qty	Beskrivelse	Designation		Acc Part No	Qty	
001	812227-329X	1	TAP Ø45 ZAPFEN Ø45	DOWEL Ø45		811241-9514	2	
						811251-6601	2	
002	812083-706B	1	VÆRKTØJ WERKZEUG	TOOL				
003	812227-334X	1	TAP Ø45 ZAPFEN Ø45	DOWEL Ø45		811251-6601	1	
004	812223-267X	2	TAP ZAPFEN	DOWEL		811254-4201	1	
005	812223-220X	1	BØJLE BUEGEL	HOOP		811241-1304	1	
						811252-3102	1	
006	812227-331X	1	TAP Ø25-36 ZAPFEN Ø25-36	DOWEL Ø25-36		811251-4301	1	
						811251-5503	1	
007	812227-341X	1	HOLDER F/ FJEDER HALTER F/ FEDER	SUPPORT F/ SPRING		811241-7802	1	
008	811432-2299	1	TREKFJEDER ZUGFEDER	TENSION SPRING				
009	811214-2126	2	STÅLSKRUE M8-45 STAHLSECHSKANTSCHRAUBE M8-45	STEEL SCREW M8-45				
010	811220-2122	3	STÅLMØTRIK M8 STAHLMUTTER M8	STEEL NUT M8				
011	812061-002X	1	KONISK SKIVE KON.SCHEIBE	CONICAL WASHER				
012	811213-5822	1	STÅLSÆTSKRUE M16X160 ST. SETSCHRAUBE M16X160	STEEL SET SCREW M16X160				
013	811220-3920	2	MØTRIK M10 MUTTER M10	NUT M10				
014	813227-347X	1	TRYKSTANG SCHWINGACHSE	DRAWBAR		811241-7802	2	
						811251-5403	2	
015	813227-338X	1	TAP Ø30 ZAPFEN Ø30	DOWEL Ø30		811220-3321	1	
016	813227-266B	1	TRANSPORTLÅS TRANSPORT SCHLOSS	TRANSPORT LOCK		811251-4301	1	
017	811241-6606	2	SPENDESKIVE 25-40-4 SCHEIBE 25-40-4	WASHER 25-40-4				
018	812227-330X	1	TAP Ø25 ZAPFEN Ø25	DOWEL Ø25		811251-4301	2	
019	812227-336X	1	TAP Ø28 ZAPFEN Ø28	DOWEL Ø28		811241-6702	4	
						811251-5304	2	
020	812227-335X	1	TAP Ø28 ZAPFEN Ø28	DOWEL Ø28		811251-5304	1	
022	813227-271X	1	OPHÆNGNINGSGAFFEL AUFHÄNUNGSGABEL	SUSPENSION FORK				
023	811335-5536	2	LEJE LAGER	BEARING				
024	813227-279X	1	GAFFEL GABEL	FORK		811165-0158	1	
						811219-0599	1	
						811220-1323	1	
						811241-1207	1	

Fig. 1



SM-0003/3		SM 2805		Figure No 001		>=B027140181148		Hertil, Dazu	
Position No Spare Part No		Qty	Beskrivelse	Designation		To this, A ceci		Acc Part No	Qty
025	812227-332X	1	STANG Ø25 STANGE Ø25	ROD Ø25					
026	812227-340X	1	BØSNING Ø65-25,2X30 BUCHSE Ø65-25,2X30	BUSH Ø65-25,2X30		811251-5504			1
027	811317-0302	1	STIK F/LYNKOBLING ANSCHLUSS F/SCHNELLKUPPLUNG	CONNECTION F/QUICK-COUPLING					
028	811311-8534	2	FORSKRUNING VERSCHRAUBUNG	SCREWED CONNECTION					
029	811317-0444	1	HYDRAULIKSLANGE L=2100 HYDRAULIKSCHLAUCH L=2100	HYDRAULIC HOSE L=2100					
030	811313-2101	1	SMØRENIPPEL SCHMIERNIPPEL	GREASE NIPPLE					
031	811399-0128	1	TAP ZAPFEN	DOWEL		811254-4201			1
032	811393-0138	1	BESKYTTELSESHETTE GUL SCHUTZKAPPE GELB	PROTECTION CAP YELLOW					
033	811254-3103	1	RØRSPLIT ROHRSPLINTE	TUBE SPLIT PIN					
034	811335-5546	2	GLIDELEJE 105-110-25 GLEITLAGER 105-110-25	SLEEVE BEARING 105-110-25					
035	811251-8901	1	SPÆNDESTIFT 16,0-110 SPANNSTIFT 16,0-110	ROLL PIN 16,0-110					
036	811214-3430	1	STÅLSKRUE M10-130 STAHLSCHRAUBE M10-130	STEEL SCREW M10-130		811220-3321			1
037	811213-3322	1	STÅLSÆTSKRUE M10-30 ST. SETSCHRAUBE M10-30	STEEL SET SCREW M10-30		811241-2502			1
038	811393-0193	1	GUMMIBUFFER 125-60-40 GUMMIPUFFER 125-60-40	RUBBERBUFFER 125-60-40		811214-2126 811220-2321 811241-1304		2 2 6	
039	813227-363X	1	STØTTEBEN ABSTELLSTÜTZE	JACK		811214-2328 811220-2321 811241-1403		1 1 2	
040	813227-379X	1	TOPRAMME TOPRAHMEN	TOP FRAME		811313-1101			1
041	811254-3201	1	SIKRINGSSPLIT 8 MM FEDERSPLINT 8 MM	SECURING PIN 8 MM					
042	811433-0292	1	LÅSEFJEDER SPERRFEDER	LOCKING SPRING					
043	812227-400X	1	BØSNING BUCHSE	BUSH					
044	812227-910X	2	BOLT M 12 BOLZEN M 12	BOLT M 12					
045	811220-4122	2	STÅLMØTRIK M12 STAHLMUTTER M12	STEEL NUT M12					
046	811317-0989	1	CYLINDER 60-25-625 ZYLINDER 60-25-625	CYLINDER 60-25-625		811241-6605			4
047	811317-0734	1	DRØVLEVENTIL DROSSELVENTIL	THROTTLE VALVE					

Fig. 1

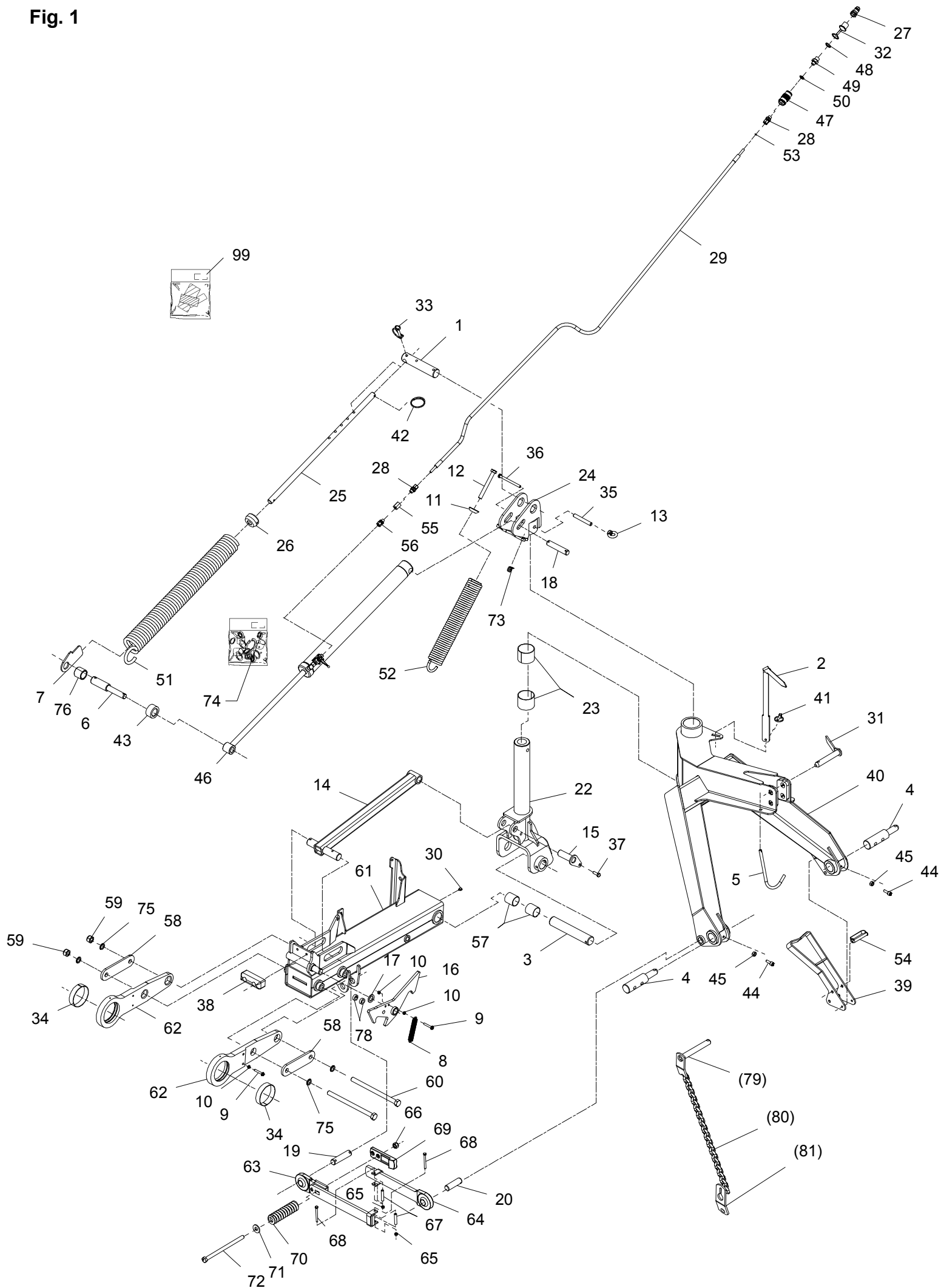

SM-0003/3		SM 2805	Figure No 001	>=B027140181148	Hertil, Dazu To this, A ceci
Position No	Spare Part No	Qty	Beskrivelse	Designation	Acc Part No Qty
048	811311-8539	1	TÆTNINGSRING DICHTUNGSRING	GASKET	
049	811311-2304	1	BRYSTNIPPEL NIPPEL	NIPPLE	
050	811311-8538	1	TÆTNINGSRING DICHTUNGSRING	GASKET	
051	813227-225X	1	TRÆKFJEDER DM80 ZUGFEDER DM80	TENSION SPRING DM80	
052	813227-227X	1	TRÆKFJEDER DM65 ZUGFEDER DM65	TENSION SPRING DM65	
053	812227-366X	1	DYSE Düse	NOZZLE	
054	810602140	1	FJEDERBOLT 12X80/95 FEDERSTECKBOLZEN 12X80/95	SAFETY PIN	
055	811311-1112	1	MUFFE 1/4 NIPPEL 1/4	BUSHING 1/4	
056	811311-1419	1	RØRSTUDS SDS-L8X1/4 -BSP ROHRSTUTZEN SDS-L8X1/4 -BSP	PIPE STUB SDS-L8X1/4 -BSP	
057	811335-5502	2	GLIDELEJE 45-50-50 GLEITLAGER 45-50-50	PLAIN BEARING 45-50-50	
058	812227-954X	2	PLADE BLECH	PLATE	
059	811220-6321	2	NYLOC MØTRIK M20 NYLOC MUTTER M20	NYLOC NUT M20	
060	811214-6822	2	STÅLSKRUE M20-290 10.9 STAHLSCRAUBE M20-290 10.9	STEELSCREW M20-290 10.9	
061	813227-250X	1	UDLIGGERBOM AUSLEGER	BOOM	
062	812227-269X	2	LEJEPLADE LAGERBLECH	BEARING PLATE	
063	813227-217X	1	VIPPESKINNE KIPPSCHIENE	SWEEP RAIL	
064	813227-218X	1	VIPPESKINNE KIPPSCHIENE	SWEEP RAIL	
065	811220-2321	2	NYLOC MØTRIK M8 NYLOC MUTTER M8	NYLOC NUT M8	
066	811220-5321	1	NYLOC MØTRIK M16 NYLOC MUTTER M16	NYLOC NUT M16	
067	812227-210X	2	RØR ROHR	TUBE	
068	811214-2326	2	STÅLSKRUE M8-80 STAHLSECHSKANTSCHR. M8-80	STEEL SCREW M8-80	
069	813225-712X	1	VIPPE HEBEVORRICHTUNG	TIPPING DEVICE	
070	811431-5698	1	TRYKFJEDER DRUCKFEDER	COMPRESSION SPRING	

Fig. 1

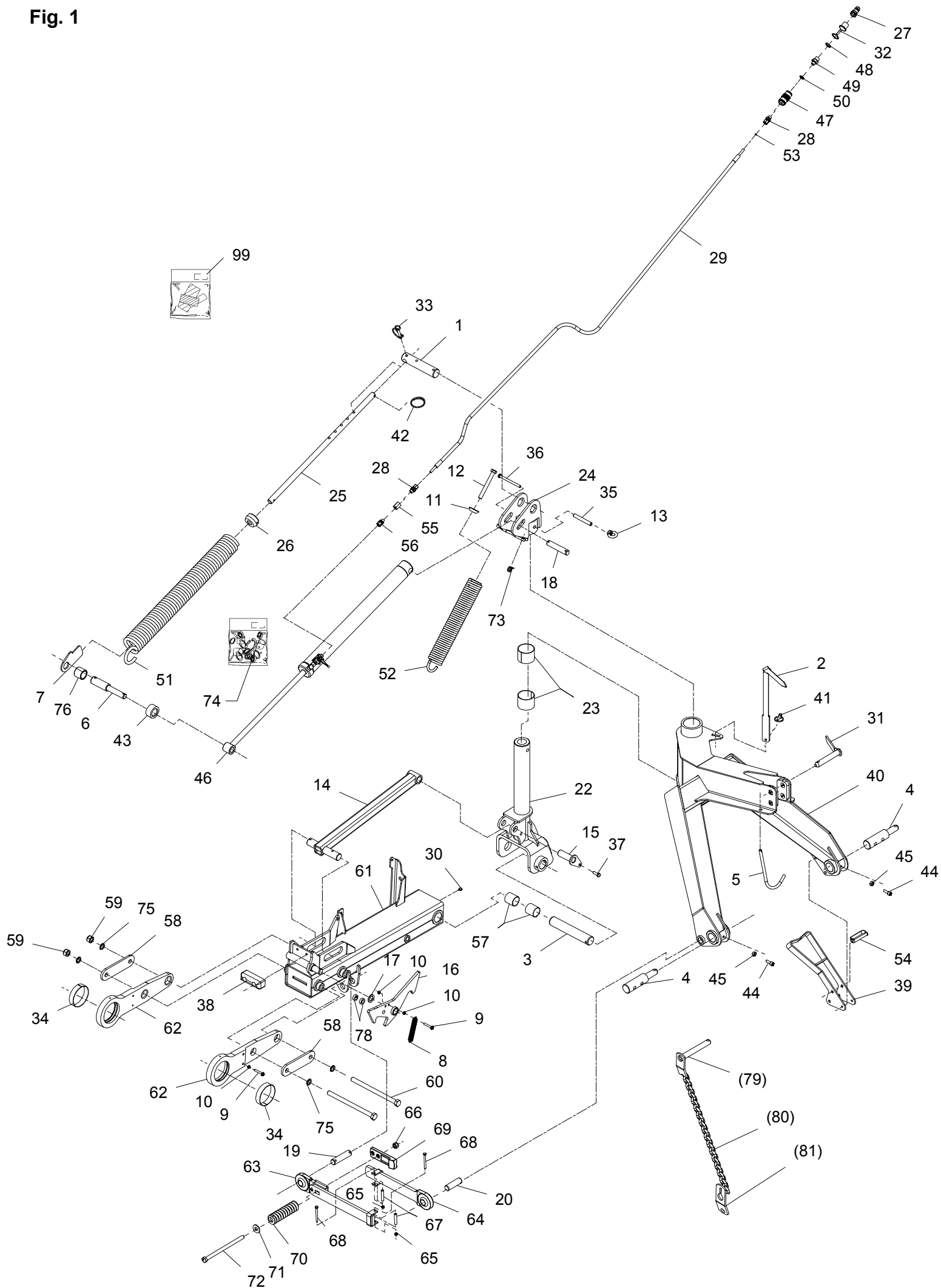

SM-0003/3		SM 2805		Figure No 001		>=B027140181148		Hertil, Dazu	
Position No Spare Part No		Qty	Beskrivelse	Designation		To this, A ceci		Acc Part No	Qty
071	811241-4601	7	SPENDESKIVE 17,5-42-4 SCHEIBE 17,5-42-4	WASHER 17,5-42-4					
072	811214-5723	1	STÅLSKRUE M16-260 STAHLSCHRAUBE M16-260	STEEL SCREW M16-260					
073	811311-8554	1	SLANGEHOLDER BESCHLAG	CLAMP					
074	811317-9830	1	PAKNINGSSÆT F/1317-0989 DICHTUNGSSATZ F/1317-0989	SET OF GASKETS F/1317-0989					
075	811241-9984	4	SPECIALSKIVE 21,4-30,7-3,4 SONDERSCHEIBE 21,4-30,7-3,4	SPEC. WASHER 21,4-30,7-3,4					
076	812227-386X	1	BØSNING BUCHSE	BUSH					
077	811399-0124	3	SNOR 1M SCHNUR 1M	STRING 1M					
078	812227-693X	2	BØSNING BUCHSE	BUSH				811213-5522	1
								811220-5321	1
079	812225-092X	T 1	TAP ZAPFEN	DOWEL					
080	813225-087X	T 1	HOLDEKÆDE HALTEKETTE	SUPPORT CHAIN					
081	812279-153X	T 1	SPENDESTYKKE SPANNSTUECK	TIGHTENING PIECE					
099	813890-117X	1	KLISTERMÆRKER SM 2805 AUFKLEBER SM 2805	TRANSFERS SM 2805					

Fig. 2

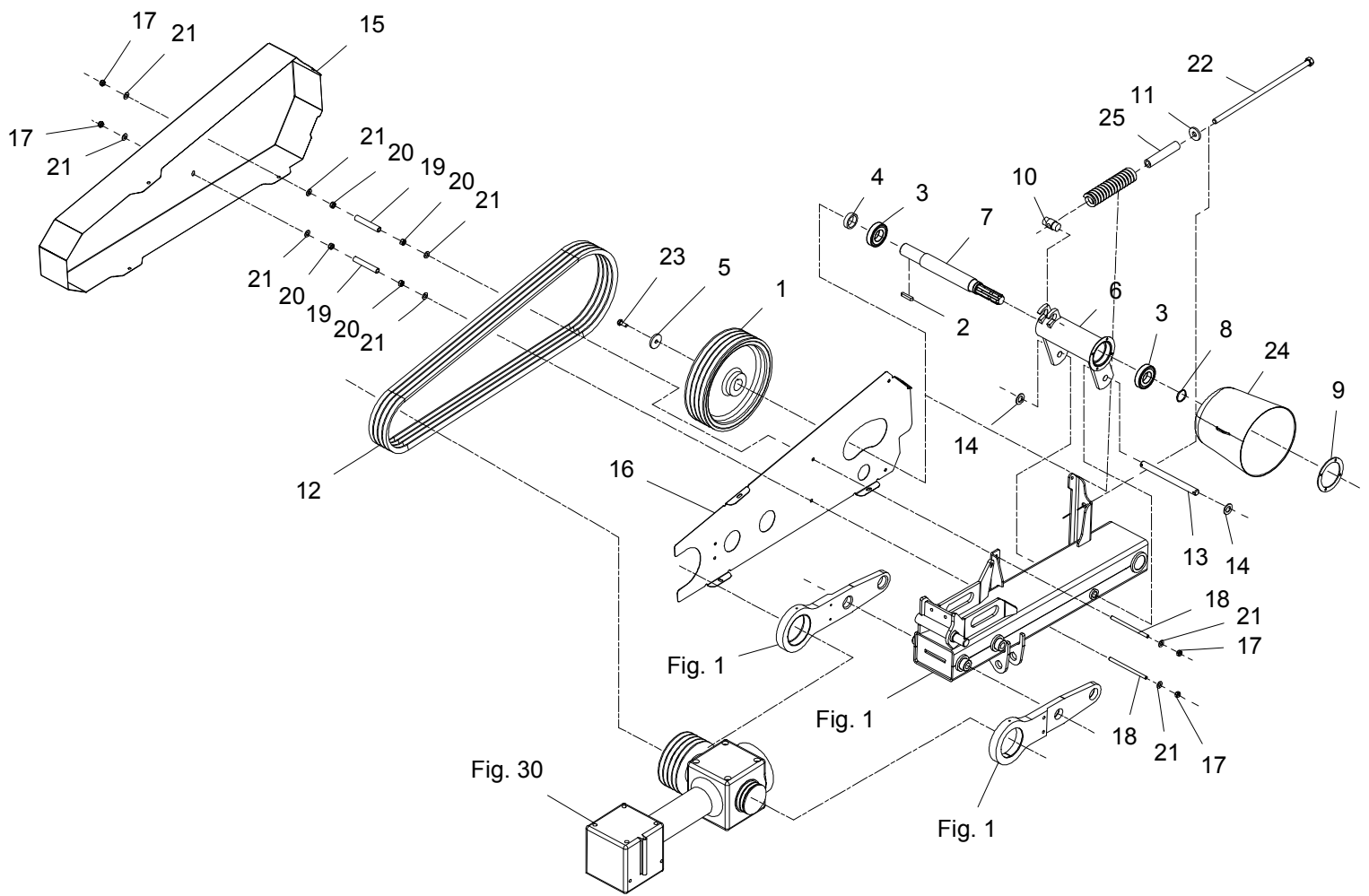

SM-0003/3		SM 2805	Figure No 002	>=B027140181148	Hertil, Dazu To this, A ceci		
Position No	Spare Part No	Qty	Beskrivelse	Designation	Acc Part No	Qty	
001	812082-130X	1	KILEREMSKIVE KEILRIEMENSCHIEBE	PULLEY			
002	811338-0105	1	PASFEDER 12-8-48 FEDERKEIL 12-8-48	FLAT KEY 12-8-48			
003	811331-3304	2	KUGLELEJE 6208 2RS KUGELLAGER 6208 2RS	BALL BEARING 6208 2RS			
004	812082-020X	1	AFSTANDSRING Distanzring	DISTANCE RING			
005	812081-059X	1	SKIVE SCHEIBE	WASHER			
006	813227-220X	1	LEJEHUS LAGERGEHÄUSE	BEARING HOUSING			
007	812227-215X	1	TRANSMISSIONSAKSEL TRANSMISSIONSWELLE	TRANSMISSION SHAFT			
008	811255-4201	1	LÅSERING 40 MM UDVENDIG SICHERUNGSRING 40 MM AUSSEN	SNAP RING 40 MM OUTER			
009	812082-144X	1	HOLDER HALTER	HOLDER			
010	812227-224X	1	REMSPÆNDERTAP RIEMENSANNERZAPFEN	BELT TIGHTENER DOWEL			
011	811241-4802	1	SPÆNDESKIVE 17,0-45-6,00 SCHEIBE 17,0-45-6,00	WASHER 17.0-45-6.00			
012	811362-9738	1	KILEREMSÆT SPB2530-LP KEILRIEMENSATZ SPB2530-LP	V-BELT SET SPB2530-LP			
013	812227-333X	1	TAP Ø20 ZAPFEN Ø20	DOWEL Ø20	811251-3202	2	
014	811241-5504	2	SPÆNDESKIVE 21-37-3 SCHEIBE 21-37-3	WASHER 21-37-3			
015	812227-343X	1	SKÆRM SCHUTZBLECH	GUARD	811213-2222	4	
					811220-2321	4	
					811241-1403	8	
016	812227-344X	1	SKÆRM SCHUTZBLECH	GUARD	811213-2222	4	
					811220-2321	1	
					811241-1304	2	
					811241-1403	4	
017	811220-3321	4	NYLOC MØTRIK M10 NYLOC MUTTER M10	NYLOC NUT M10			
018	812227-346X	2	SKÆRMBOLT SCHUTZBLECHBOLZEN	GUARD BOLT			
019	812227-345X	2	AFSTANDSRØR Distanzrohr	DISTANCE TUBE			
020	811220-3122	2	STÅLMØTRIK M10 STAHLMUTTER M10	STEEL NUT M10			
021	811241-2502	6	SPÆNDESKIVE 10,5-22-3 SCHEIBE 10,5-22-3	WASHER 10,5-22-3			
022	813227-229X	1	SPINDEL SPINDEL	SPINDLE			

Fig. 2

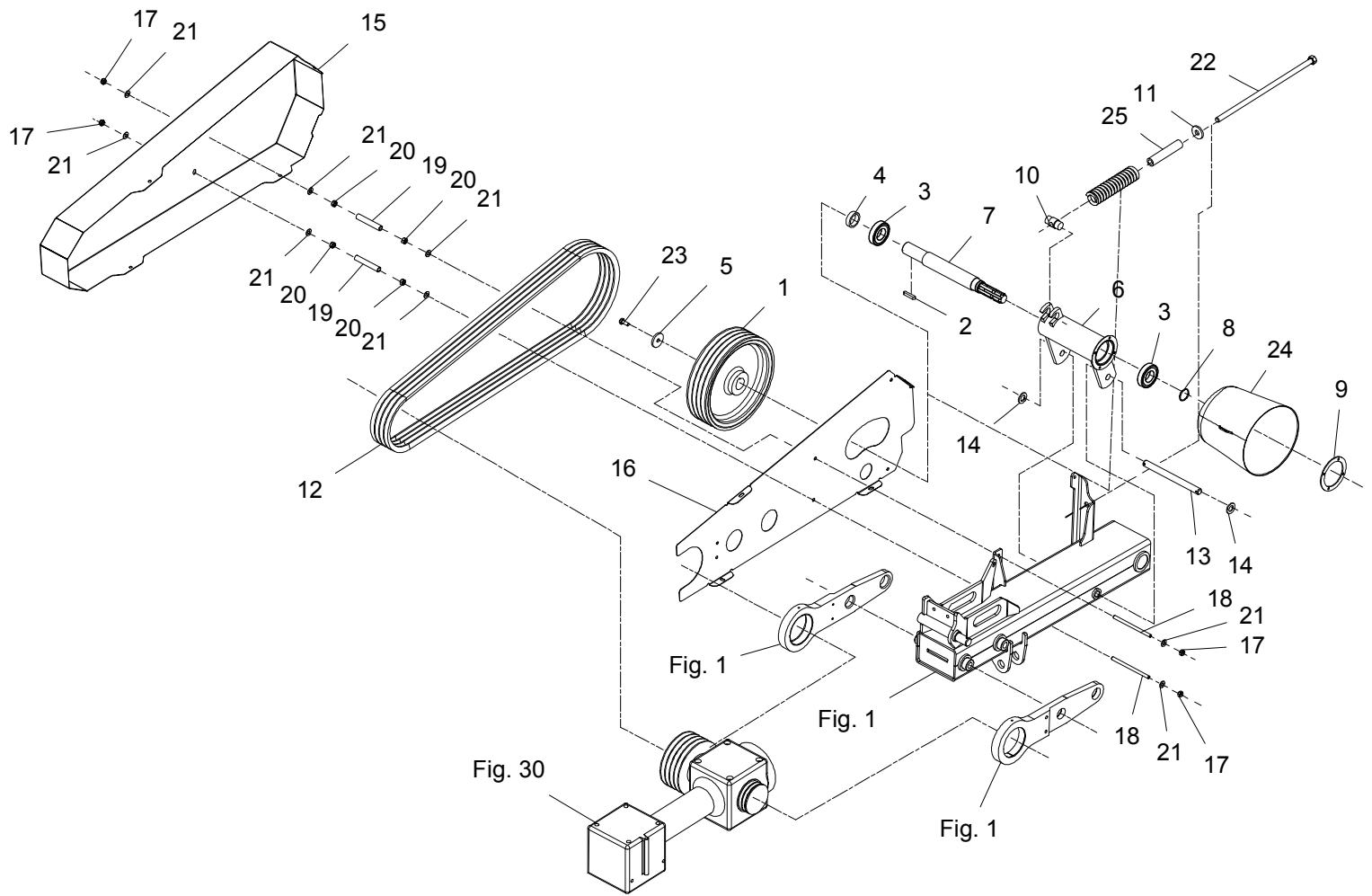

SM-0003/3		SM 2805		Figure No 002		>=B027140181148		Hertil, Dazu	
Position No Spare		Part No	Qty	Beskrivelse	Designation	To this, A ceci		Acc Part No	Qty
023	811213-3225	1	1	STÅLSÆTSKRUE M10-25 KV. 10.9 ST. SETSCHRAUBE M10-25 Q.10.9	ST. SET SCREW M10-25 10.9	811242-3221			1
024	811393-0174	1	1	PTO-SKÆRM, OVAL PTO-SCHUTZ, OVAL	PTO-GUARD, OVAL	811213-1126			4
						811220-1323			4
						811241-1201			4
025	812227-552X	1	1	BØSNING BUCHSE	BUSH				
026	811431-6696	1	1	TRYKFJEDER DRUCKFEDER	COMPRESSION SPRING				

Fig. 3

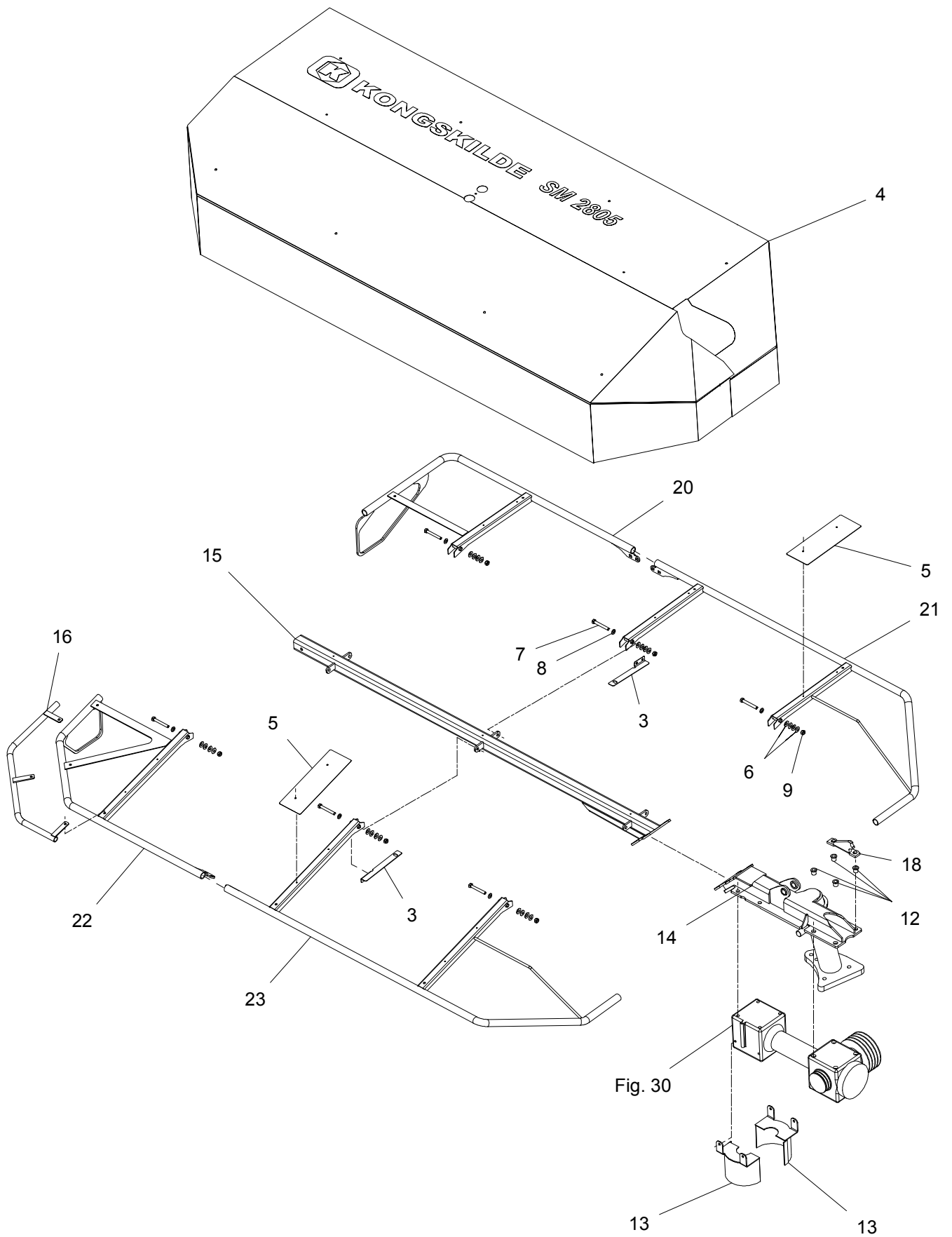

SM-0003/3		SM 2805		Figure No 003		>=B027140181148		Hertil, Dazu	
Position No Spare Part No		Qty	Beskrivelse	Designation		Acc Part No		Qty	
003	811433-0325	2	LÅSEFJEDER SCHLOSSFEDER	SPRING					
004	813227-958B	1	DUG SM 2805 TUCH SM 2805	CANVAS SM 2805					
005	812227-193X	2	TRANSFERPLADE AUFKLEBER BLECH	STICKER PLATE		811219-0599			2
006	811434-0107	24	TALLERKENFJEDER 12,2-28-1 TELLERFEDER 12,2-28-1	DISC SPRING 12,2-28-1					
007	811213-4724	6	STÅLSÆTSKRUE M12-90 ST. SETSCHRAUBE M12-90	STEEL SET SCREW M12-90					
008	811241-3403	6	SPÆNDESKIVE 13-25-2,5 SCHEIBE 13-25-2,5	WASHER 13-25-2,5					
009	811220-4321	6	NYLOC MØTRIK M12 NYLOC MUTTER M12	NYLOC NUT M12					
012	812227-270X	4	BØSNING Ø28-16X23,5 BUCHSE Ø28-16X23,5	BUSH Ø28-16X23,5					
013	813227-310X	2	SKÆRM SCHUTZBLECH	GUARD		811213-3222			1
						811241-2502			1
014	813227-284X	1	GEARKONSOL GETRIEBEKONSOLE	GEAR BRACKET		811213-5424			8
						811213-5622			5
						811241-4502			4
015	813227-900X	1	DUGHOLDER HALTER FÜR TUCH	SUPPORT FOR CANVAS		811214-4422			1
						811219-0599			3
						811220-4321			1
						811220-5122			4
						811241-1407			3
016	813227-946X	1	RØR ROHR	TUBE					
018	813227-690X	1	FORAGERSTOP STOPP F. VORGEWENDE	STOP F. HEADLAND		811214-5220			2
						811241-4604			2
020	813227-983X	1	BØJLE, BAGERST YDRE BÜGEL HINTERE ÅUSERE	HOOP, REAR OUTER					
021	813227-990X	1	BØJLE, BAGERST INDRE BÜGEL HINTERE INNERE	HOOP, REAR INNER		811213-3222			2
						811220-3321			2
						811241-2502			2
						811433-0325			1
022	813227-988X	1	BØJLE, FORREST YDRE BÜGEL VORDERE ÅUSERE	HOOP, FRONT OUTER					
023	813227-992X	1	BØJLE, FORREST INDRE BÜGEL VORDERE INNERE	HOOP, FRONT INNER		811213-3222			2
						811220-3321			2
						811241-2502			2
						811433-0325			1

Fig. 4.1

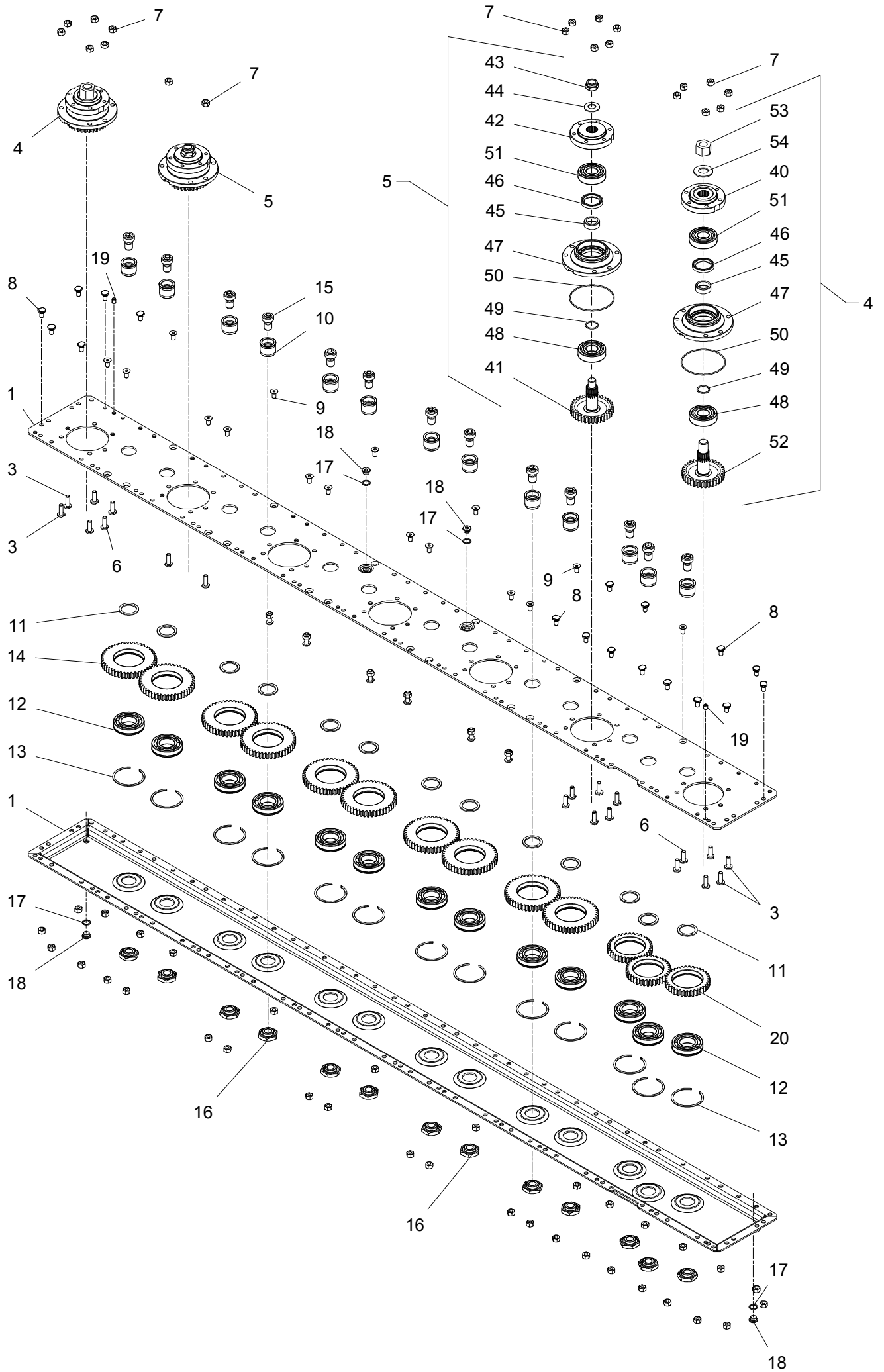

SM-0003/3	SM 2805	Figure No	004	>=B027140181148	Hertil, Dazu
Position No	Spare Part No	Qty	Beskrivelse	Designation	To this, A ceci Acc Part No Qty
000	812363-404X	1	KNIVBJÆLKE 7 SKIVER MÄHBALKEN 7 SCHEIBEN	CUTTERBAR 7 DISC	
001	813085-757X	1	KNIVBJÆLKE HALVDELE 7-SK SCHNITTBALKEN-TEILE	CUTTERBAR-PARTS	
003	811219-0210	28	SKRUE M10-30 12.9 DELTA B SCHRAUBE M10-30 12.9 DELTA B	SCREW M10-30 12.9 DELTA B	
004	813085-738A	2	LEJEHUS DREV RITZEL LAGERGEHÄUSE	PINION BEARINGHOUSING	
005	813085-705X	5	LEJEHUS LAGERGEHÄUSE	BEARING HOUSING	
006	812085-733X	14	KNIVBJÆLKE SKRUE SCHNITTBALKEN SCHRAUBE	SCREW FOR CUTTERBAR	
007	812085-729X	92	MØTRIK M10 H=10 MUTTER M10 H=10	NUT M10 H=10	
008	811219-0208	34	KNIVBJÆLKE SKRUE SCHNITTBALKEN SCHRAUBE	SCREW FOR CUTTERBAR	
009	811219-0227	13	UNBRACOSKRUE M10-20 MK INNENSECHSKANTSCHR M10-20 MK	ALLEN SCREW M10-20 MK	
010	812085-717X	13	TAP ZAPFEN	DOWEL	
011	812085-719X	13	SKIVE 40,3X51,3X3 SCHEIBE 40,3X51,3X3	WASHER 40,3X51,3X3	
012	812085-720X	13	LEJE 6208 N/C3 LAGER 6208 N/C3	BEARING 6208 N/C3	
013	812085-721X	13	SPRINGRING KLEMMRING	SPRINGRING	
014	812085-724X	10	MELLEMHJUL Z45 M3 ZWISCHENRAD Z45 M3	INTERMEDIATE WHEEL Z45 M3	
015	812085-718X	13	SKRUE M20X18 SCHRAUBE M20X18	SCREW M20X18	
016	812085-723X	13	MØTRIK MUTTER	NUT	
017	811315-9671	4	SKIVE 17 X 22 X 1,5 SCHEIBE 17 X 22 X 1,5	WASHER 17 X 22 X 1,5	
018	812085-731X	4	PROP 3/8 VERSCHLUSS 3/8	PLUG 3/8	
019	812085-735X	2	SPÆNDSTIFT M10X12 D1481 SPANNSTIFT M10X12 D1481	ROLL PIN M10X12 D1481	
020	812085-722X	3	MELLEMHJUL Z36 M3 ZWISCHENRAD Z36 M3	INTERMEDIATE WHEEL M36 M3	
040	812085-739X	1	FLANGE FLANSCH	FLANGE	
041	812085-706X	1	TANDHJUL Z34 M20 ZAHNRAD Z34 M20	SPROCKET WHEEL Z34 M20	
042	812085-707X	1	FLANGE FLANSCH	FLANGE	

Fig. 4.1

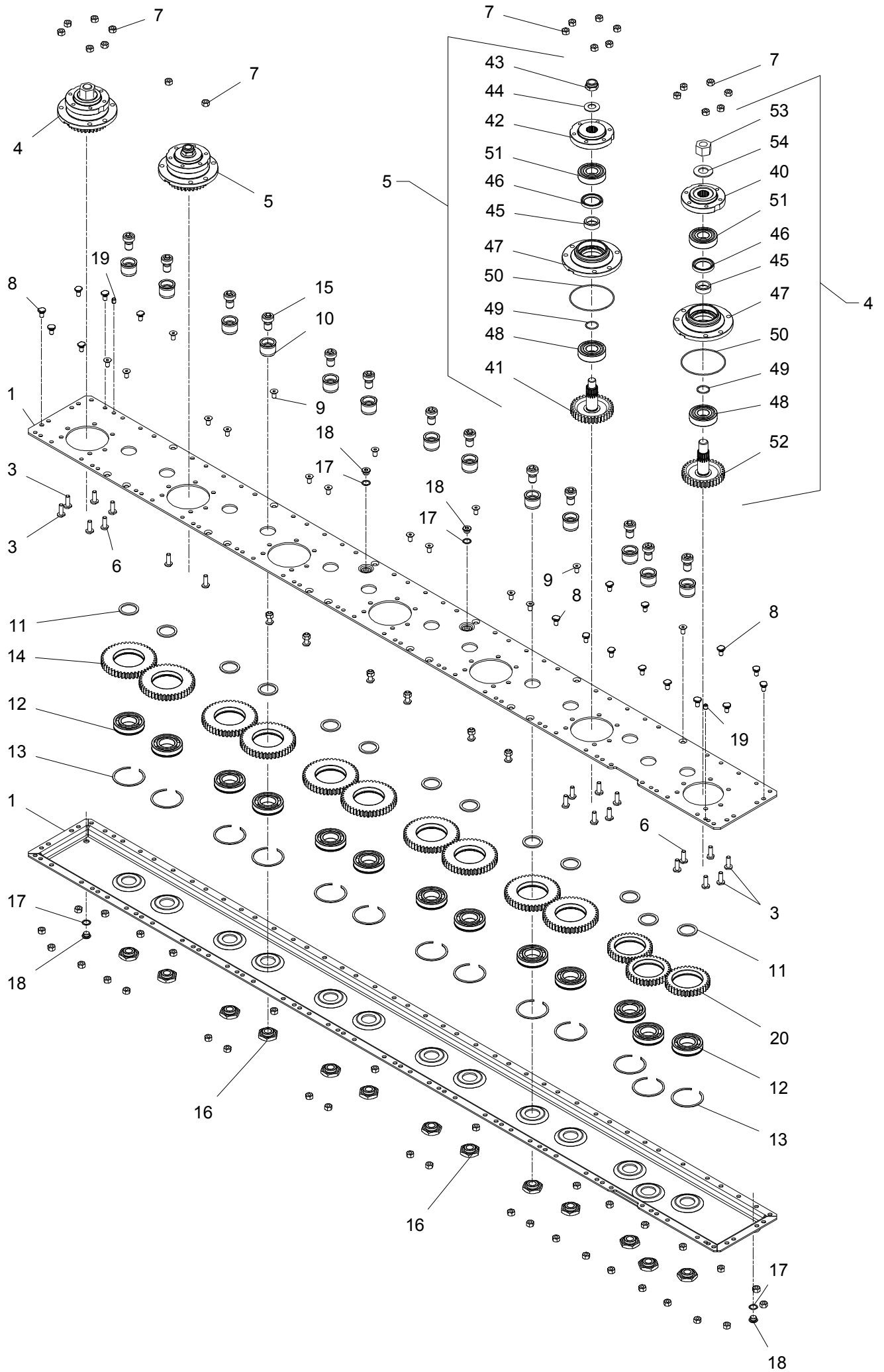

SM-0003/3		SM 2805	Figure No 004	>=B027140181148	Hertil, Dazu To this, A ceci
Position No	Spare Part No	Qty	Beskrivelse	Designation	Acc Part No Qty
043	812085-709X	1	LÅSEMØTRIK M20X1,5 GEGENMUTTER M20X1,5	LOCK NUT M20X1,5	
044	811434-0108	1	TALLERKENFJEDER 20,0-40-2,5 TELLERFEDER 20,0-40-2,5	DISC SPRING 20,0-40-2,5	
045	812085-710X	1	BØSNING BUCHSE	BUSH	
046	812085-711X	1	OLIETÆTNINGSRING DICHTUNGSRING ÖL	SEAL RING OIL	
047	812085-708X	1	LEJEHUS LAGERGEHAEUS	BEARING HOUSING	
048	812085-712X	1	LEJE 6306C3/Z2 LAGER 6306C3/Z2	BEARING 6306C3/Z2	
049	812085-714X	1	O-RING 3112 O-RING 3112	O-RING 3112	
050	812085-715X	1	O-RING O-RING	O-RING	
051	812085-716X	1	KUGLELEJE 6306 C3 2RS KUGELLAGER 6306 C3 2RS	BALL BEARING 6306 C3 2RS	
052	812085-750X	1	TANDHJUL Z34 M24 ZAHNRAD Z34 M24	SPROCKET WHEEL Z34 M24	
053	812085-751X	1	LÅSEMØTRIK M24X1,5 GEGENMUTTER M24X1,5	LOCK NUT M24X1,5	
054	811434-0111	1	TALLERKENFJEDER 25,4-50-3 TELLERFEDER 25,4-50-3	DISC SPRING 25,4-50-3	

Fig. 5

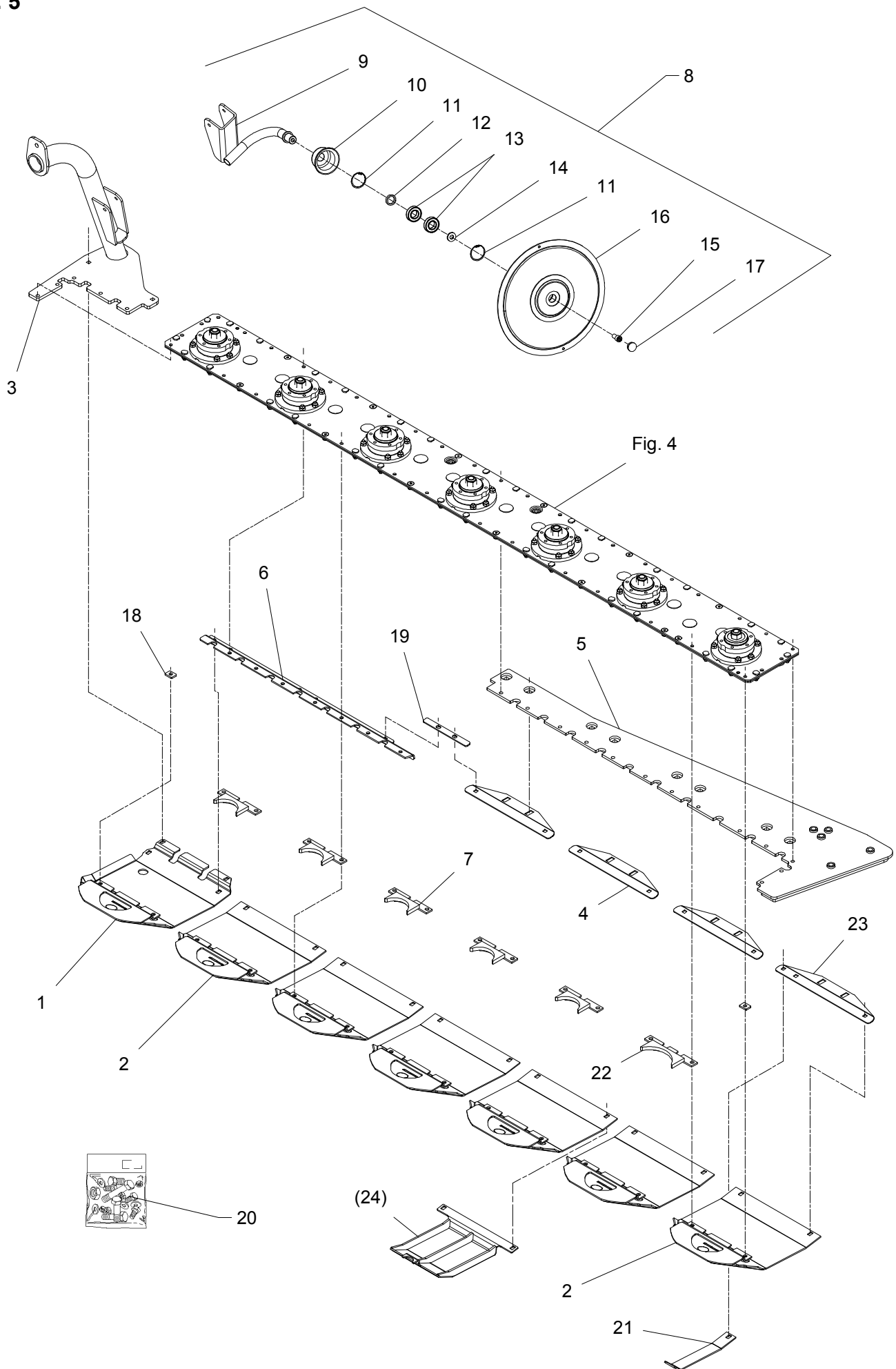

SM-0003/3	SM 2805	Figure No	005	>=B027140181148	Hertil, Dazu	To this, A ceci
Position No	Spare Part No	Qty	Beskrivelse	Designation	Acc Part No	Qty
001	813088-564X	1	SLÆBESKO, YDRE GLEITKUFE, ÆUSSER	GUIDE SHOE, OUTER	811215-3226 811220-3321	4 4
002	813088-549X	6	SLÆBESKO GLEITKUFE	GUIDE SHOE	811215-3222 811219-0210 811220-3321	2 2 4
003	813227-919X	1	KONSOL KONSOLE	BRACKET	811215-3226 811220-3321	2 2
004	812227-932X	3	ADAPTER ADAPTER	ADAPTER		
005	813227-939X	1	FORSTÆRKNING VERSTÄRKERUNG	REINFORCEMENT	811215-4328 811219-0209 811220-3321 811220-4321	8 13 13 8
006	812227-943X	1	FORSTÆRKNING VERSTÄRKERUNG	REINFORCEMENT	811219-0209 811220-3321	10 10
007	813088-554A	5	MODSKÆR GEGENSCHNEIDE	SHEAR BAR		
008	813088-076X	1	SKÅRRULLE, SML. SCHWADROLLE SATZ	SWATH ROLLER SET		
009	813088-050X	1	ARM F. SKÅRRULLE ARM F. SCHWADROLLE	ARM F. SWATH ROLLER	811214-3328 811220-3321	1 1
010	812279-221X	1	DEKSEL DECKEL	COVER		
011	811255-4102	2	LÅSERING 47 MM INDVENDIG SICHERUNGSRING 47 MM INNEN	SNAP RING 47 MM INNER		
012	812279-223X	1	AFSTANDSRING Distanzring	DISTANCE RING		
013	811331-2303	2	KUGLELEJE 6005 2RS KUGELLAGER 6005 2RS	BALL BEARING 6005 2RS		
014	812279-023X	1	SKIVE SCHEIBE	WASHER		
015	811219-0220	1	UNBRACOSKRUE M12-25 MC INNENSECHSKANTSCHR. M12-25 MC	ALLEN SCREW M12-25 MC		
016	813279-502X	1	TALLERKEN SCHEIBE	REINFORCED DISC		
017	811165-0189	1	AFDEKNINGSPROP ABDECKUNGSVERSCHLUSS	COVERING PLUG		
018	812088-566X	2	MELLEMLÆG DICHTUNG	DISTANCE PIECE		
019	812227-931X	1	PLADE BLECH	PLATE	811215-3226 811220-3321	2 2
020	813088-526X	1	BOLTSET BOLZENSATS	SET OF BOLTS		
021	812088-560X	1	SLÆBESKO GLEITKUFE	GUIDE SHOE	811215-3222 811220-3321	1 1
022	813089-703X	1	MODSKÆR GEGENSCHNEIDE	SHEAR BAR		

Fig. 5

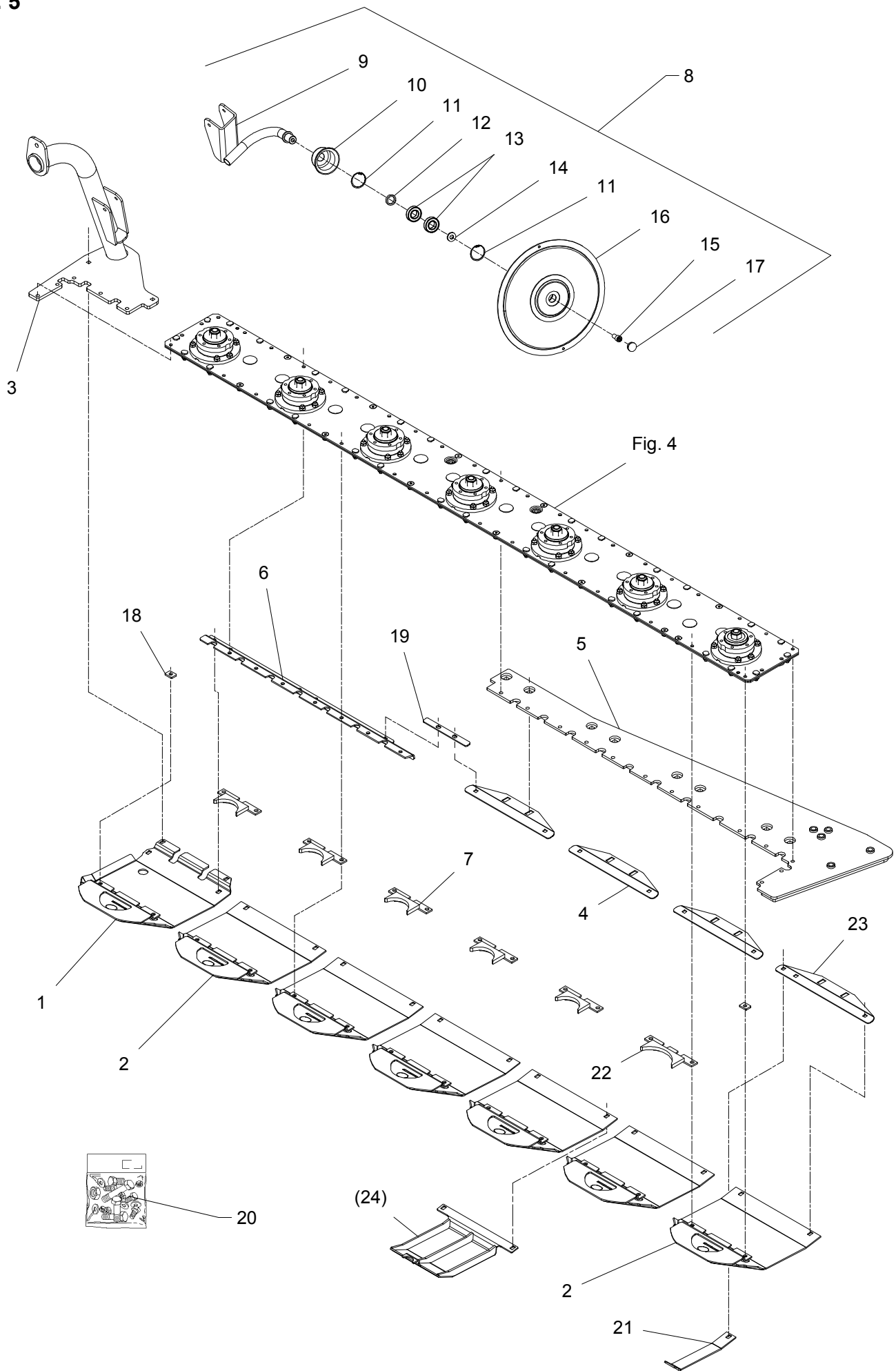

SM-0003/3		SM 2805		Figure No 005		>=B027140181148		Hertil, Dazu	
Position No		Spare Part No		Qty		Beskrivelse		Designation	
								To this, A ceci	
								Acc Part No Qty	
023	812227-942X	1	ADAPTER ADAPTER		ADAPTER				
024	813088-584X	T 7	SLÆBESKO, HØJ GLEITKUFE, HOCH		GUIDE SHOE, HIGH	811215-3226	2		
						811220-3321	2		

Fig. 6

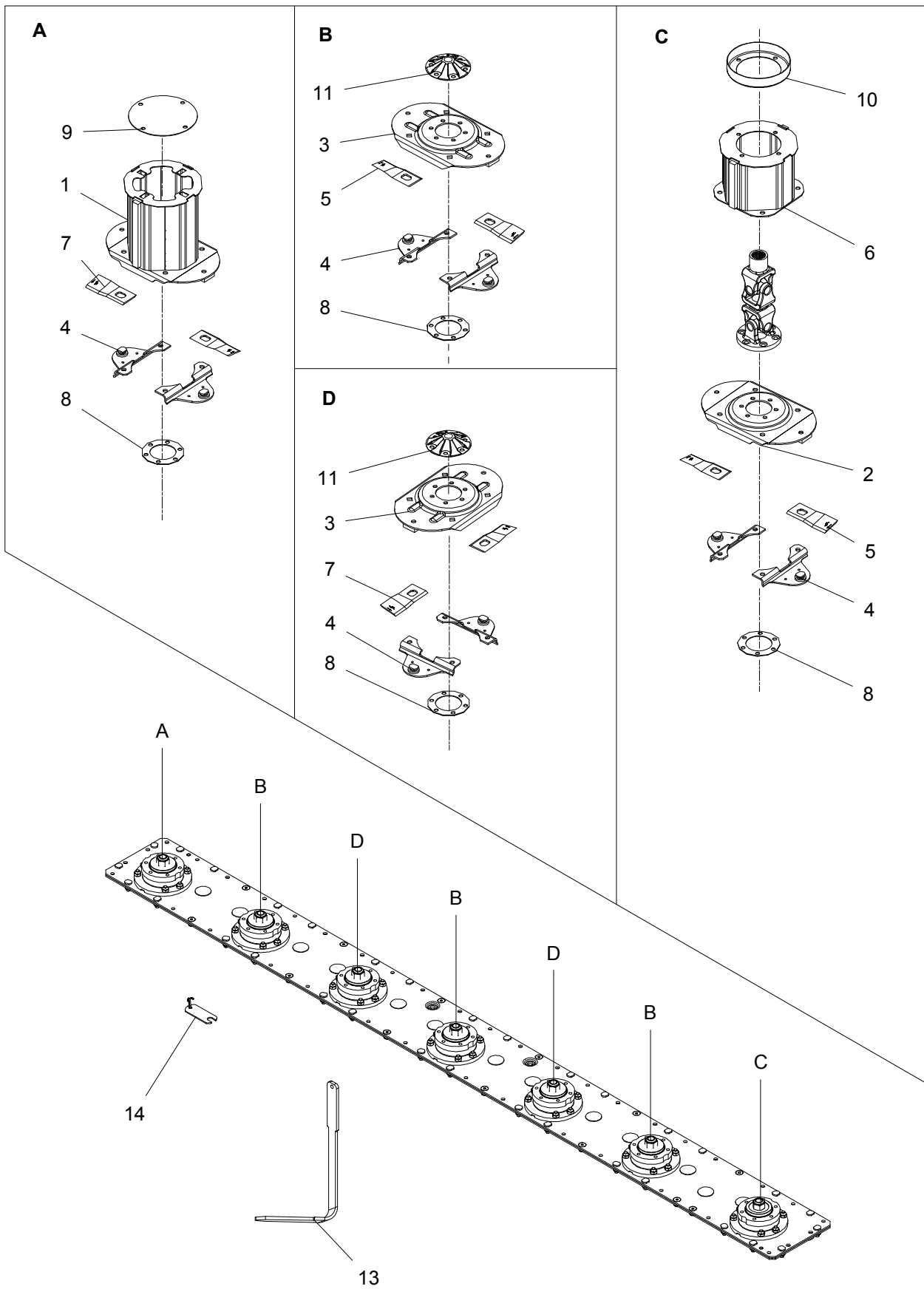

SM-0003/3		SM 2805		Figure No 006		>=B027140181148		Hertil, Dazu	
Position No Spare		Part No	Qty	Beskrivelse	Designation	To this, A ceci		Acc Part No	Qty
001	813088-541X	1	SKIVE SCHEIBE	DISC	811213-3222	4	811220-3922	4	
002	813088-539X	1	INDGANGSSKIVE ANTRIEBSSCHEIBE	INPUT DISC					
003	813088-536X	5	SKIVE SCHEIBE	DISC	811215-4220	4	811220-4323	4	
					811241-3403	4			
004	813229-517A	14	KNIVHOLDER MESSERHALTER	KNIFE HOLDER	811219-0245	2	811220-4323	2	
					811241-3403	2			
005	811380-0047	8	KNIV H. VREDET 55-4-134 MESSER, RECHTE	KNIFE, RIGHT					
006	813087-449A	1	TROMLE, INDGANG TROMMEL, EIN	BARREL, IN	811213-3224	4	811219-0290	4	
					811220-3323	4			
007	811380-0046	6	KNIV, VENSTRE MESSER, LINKS	KNIFE, LEFT					
008	812085-704X	7	MELLEMLÆG DICHTUNG	DISTANCE PIECE					
009	812089-180X	1	TÆTNING DICHTUNG	SEAL					
010	812225-397X	1	TÆTNING DICHTUNG	SEAL	811213-3224	8			
011	812085-703X	5	TOP OBERTEIL	TOP	811213-3224	6	811241-2402	6	
012	811350-0146	1	BJÆLKEDREV L=275 MM RÅDERKASTENRITZEL	BEAM PINION	811219-0323	6			
013	812083-706B	1	VÆRKTØJ WERKZEUG	TOOL					
014	813210-436X	1	KONTROLLÈRE KONTROLLEHRE	CONTROL GAUGE					

Fig. 30

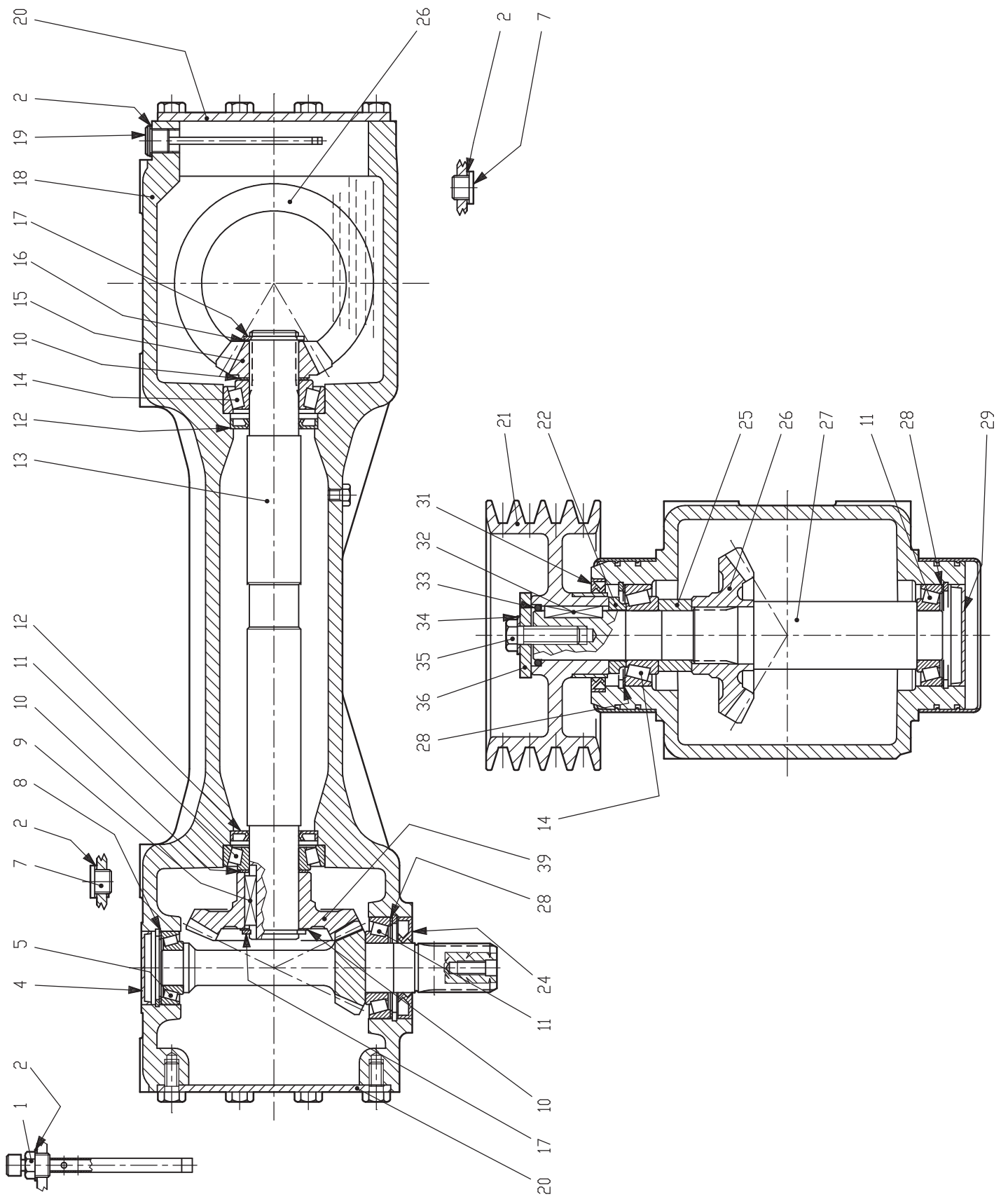

SM-0003/3	SM 2805	Figure No	030	>=B027140181148	Hertil, Dazu To this, A ceci
Position No	Spare Part No	Qty	Beskrivelse	Designation	Acc Part No Qty
000	811315-0225	1	VINKKELGEAR WINKELGETRIEBE	ANGULAR GEAR	
001	811315-9670	1	PROP ROHRVERSCHLUSS	PLUG	
002	811315-9671	4	SKIVE 17 X 22 X 1,5 SCHEIBE 17 X 22 X 1,5	WASHER 17 X 22 X 1,5	
004	811315-9672	1	DEKSEL 52X7 DECKEL 52X7	CAP 52X7	
005	811315-9673	1	LEJE LAGER	BEARING	
007	811315-9674	2	OLIEPROP 3/8 GAS ÖLROHRVERSCHLUSS 3/8 GAS	OIL DRAIN PLUG 3/8 GAS	
008	811315-9109	1	AFSTANDSRING, SET DISTANZRING, SATZ	DISTANCE RING, SET	
009	811315-9274	1	PASFEDER FEDERKEIL	FLAT KEY	
010	811315-9140	3	SKIVESET DISTANZSCHEIBENSATZ	SET OF SHIMS	
011	811331-9909	3	RULLELEJE ROLLENLAGER	ROLLER BEARING	
012	811315-9675	2	OLIETÆTNINGSRING ÖLDICHTUNGSRING	OIL TIGHTNING RING	
013	811315-9676	1	AKSEL WELLE	SHAFT	
014	811315-9430	2	LEJE LAGER	BEARING	
015	811315-9677	1	TANDHJUL Z13 ZAHNRAD Z13	PINION Z13	
016	811315-9678	1	SKIVE 5,5 X 41,7 SCHEIBE 5,5 X 41,7	WASHER 5,5 X 41,7	
017	811315-9429	2	LÅSERING SICHERUNGSRING	SNAP RING	
018	811315-9679	1	HUS FOR GEARKASSE GETRIEBEHÄUSE	GEARBOX	
019	811315-9680	1	PROP 3/8 GAS ROHRVERSCHLUSS 3/8 GAS	PLUG 3/8 GAS	
020	811315-9681	2	DEKSEL DECKEL	COVER	
021	811315-9682	1	REMSKIVE RIEMENSCHIEBE	PULLEY	
022	811315-9683	1	AFSTANDSSTYKKE DISTANZSTÜCK	SPACER	
024	811315-9684	1	OLIETÆTNING 35X72X10 ÖLDICHTUNG 35X72X10	OIL TIGHTNING 35X72X10	
025	811315-9685	1	AFSTANDSSTYKKE DISTANZSTÜCK	SPACER	

Fig. 30

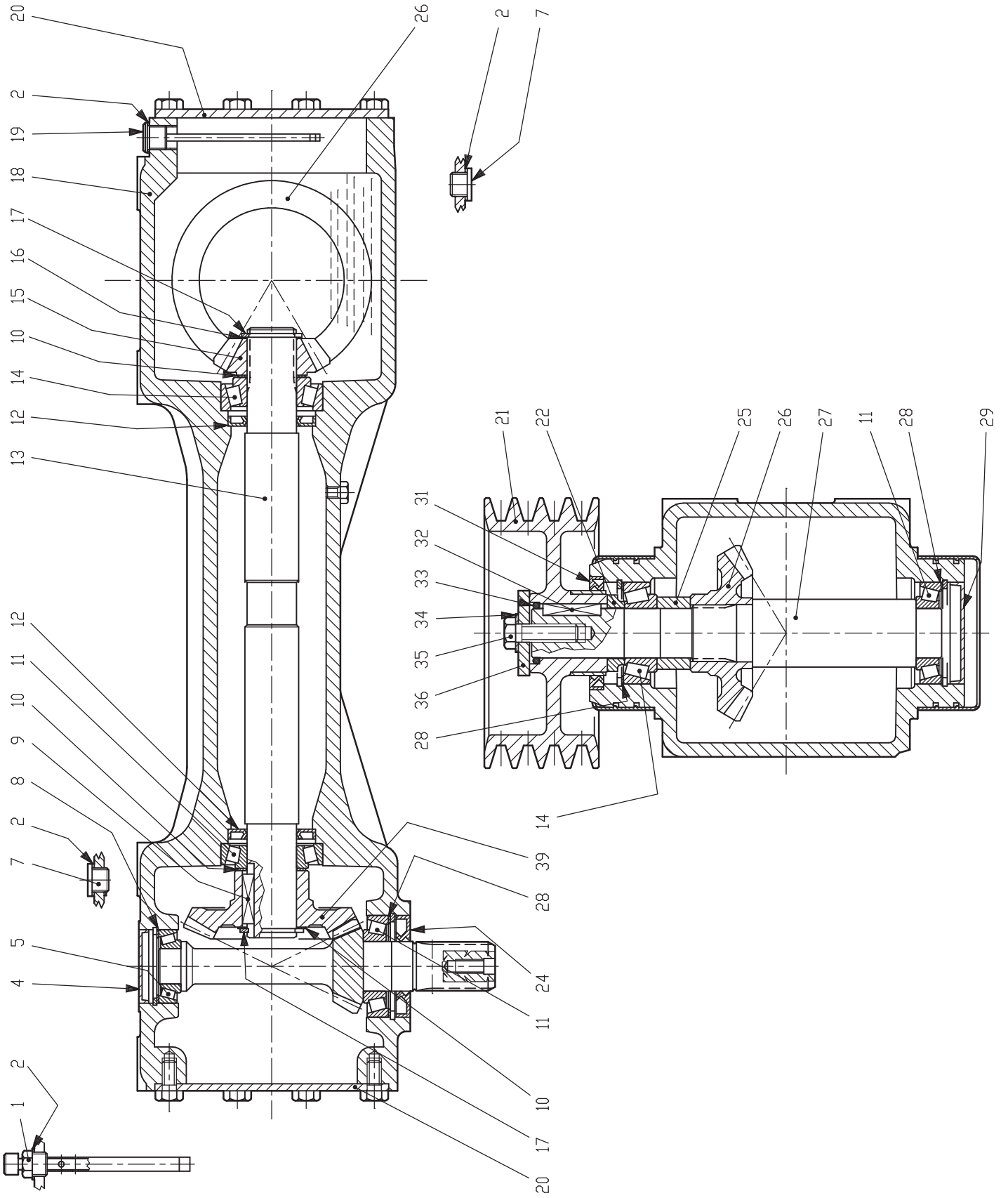

SM-0003/3		SM 2805	Figure No	030	>=B027140181148	Hertil, Dazu
					To this, A ceci	
Position No	Spare Part No	Qty	Beskrivelse	Designation	Acc Part No	Qty
026	811315-9686	1	TANDHJUL Z22 TAHNRAD Z22	PINION Z22		
027	811315-9687	1	AKSEL WELLE	SHAFT		
028	811315-9142	3	TETNINGSRING DICHTUNGSRING	TIGHTENING RING		
029	811315-9237	1	DEKSEL DECKEL	COVER		
031	811315-9874	1	TETNINGSRING WELLENDICHTRING	RADIAL SEAL		
032	811338-0115	1	PASFEDER 10-8-40 FEDERKEIL 10-8-40	FLAT KEY 10-8-40		
033	811315-9688	1	O-RING 34,29 X 5,33 O-RING 34,29 X 5,33	O-RING 34,29 X 5,33		
034	811315-9689	1	SKIVE 12,4 X 27 X 1,8 SCHEIBE 12,4 X 27 X 1,8	WASHER 12,4 X 27 X 1,8		
035	811315-9690	1	BOLT DCRT 320 BOLZEN DCRT 320	BOLT DCRT 320		
036	811315-9691	1	SKIVE 13 X 60 X 8 SCHEIBE 13 X 60 X 8	WASHER 13 X 60 X 8		
039	811315-9692	1	TANDHJUL Z33 ZAHNRAD Z33	SPROCKET WHEEL Z33		

Fig. 40

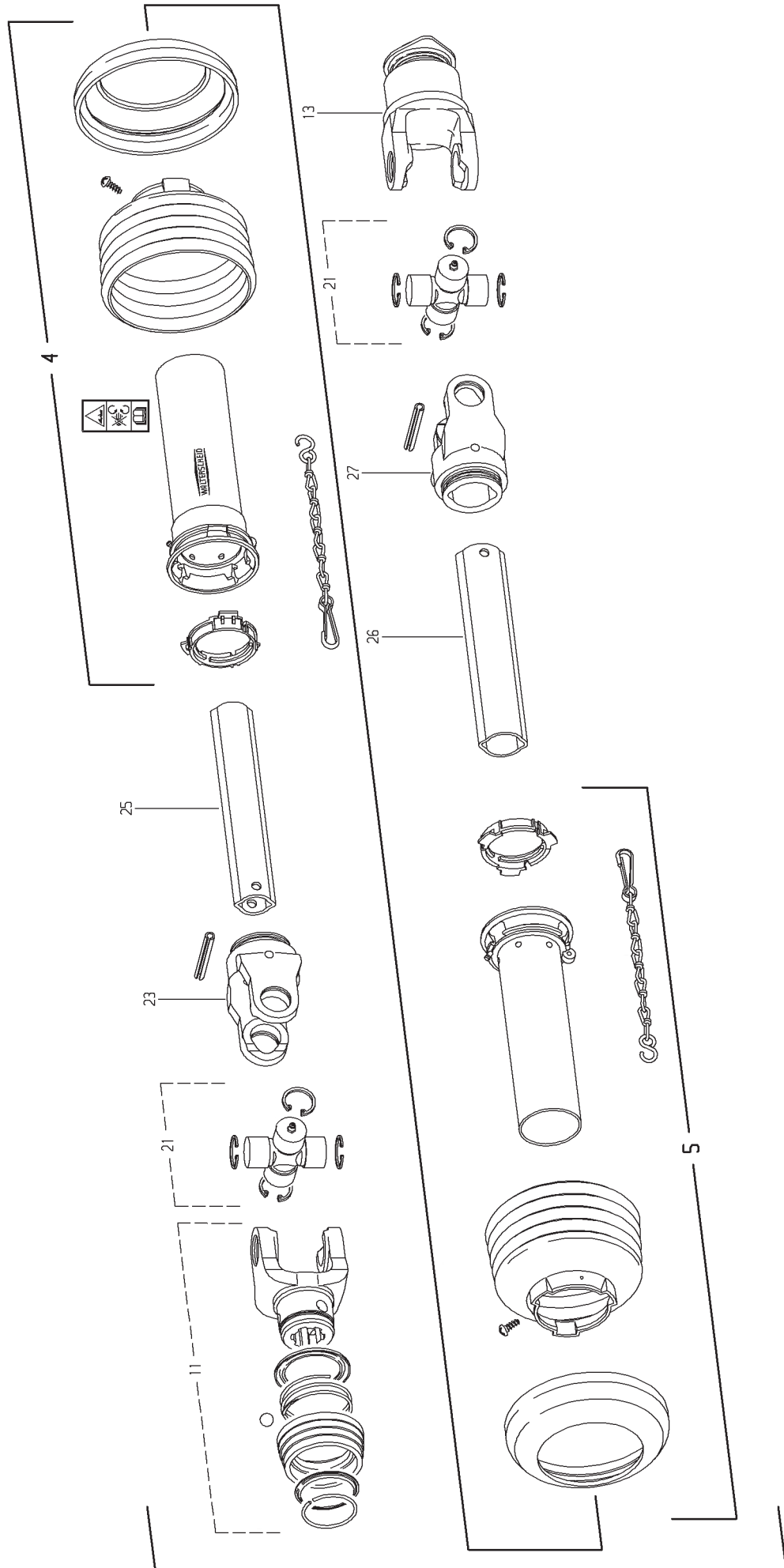

SM-0003/3		SM 2805	Figure No 040	>=B027140181148	Hertil, Dazu To this, A ceci
Position No	Spare Part No	Qty	Beskrivelse	Designation	Acc Part No Qty
000	811340-5220	1	KRAFTOVERFØRING GELENKWELLE	PTO SHAFT	
004	811342-3088	1	BESKYTTELSESRØR, UDV. SCHUTZROHR, AUSSEN	PROTECTION TUBE, OUTER	
005	811342-3089	1	RØR, INDV. SCHUTZ, INNERE	GUARD, INNER	
011	811340-9213	1	GAFFEL GABEL	YOKE	
013	811340-9135	1	STIFTFRILØB F5/1R-W2400 STIFTFREILAUF F5/1R-W2400	FREE WHEEL F5/1R-W2400	
021	811340-9212	2	KRYDS KREUTZGARNITURE	CENTRE CROSS	
023	811340-9022	1	SPÆNDEGAFFEL KLEMMGABEL	CLAMP FORK	
025	811501-0107	1	PROFILRØR 1B 1000 MM PROFILROHR GR.1B 1000 MM	PROFILE TUBE SIZE 1B 1000MM	
026	811501-0108	1	PROFILRØR 2 A 1000 MM PROFILROHR GR.2 A 1000 MM	PROFILE TUBE 2A 1000MM	
027	811340-9023	1	SPÆNDEGAFFEL KLEMMGABEL	CLAMP FORK	



Kongskilde Agriculture

www.kongskilde.com

 **KONGSKILDE**
Moving agriculture ahead