

SB 2005



A01

Valid from: | Gültig ab:
Valable á partir de: | Gyldig fra:
15.09.2017

Serial No.: | Maschinen Nr.:
No. de serie: | Fabrikationsnr.:
B029040171108

You can always find the latest
version of the Spare Parts List at
www.kongskilde.com

Reservedelsliste
Spare parts list
Ersatzteilliste
Liste de pièce de rechange

Always state the serial number and if possible the year of the machine when ordering spare parts whereby you save time and money and facilitates matters for us.
Please enter the number of your machine here:

No..... Delivered on the / 20.....
Appropriate when ordering parts.
The serial number is located as shown on the figure.

Bei Ersatzteilbestellungen ist die Fabrikationsnummer Ihrer Maschine unbedingt anzugeben.
Das erspart Ihnen Zeit, Geld und Ärger und erleichtert uns die Abfertigung.
Tragen Sie die Nummer Ihrer Maschine bitte hier ein:

Nr..... Geliefert am / 20.....
dann haben Sie bei Ersatzteilbestellungen immer die Nummer bei der Hand.
Die Fabrikationsnummer ist im Rahmen eingeschlagen, siehe Figur.

Lorsque vous commandez des pièces détachées, indiquez toujours le numéro de série de votre machine et si possible son année de fabrication. Vous éviterez des pertes de temps et vous nous faciliterez le travail.
Prière de noter ici le numéro de série de votre machine:

Numéro..... Livrée le / 20.....

Ceci vous sera utile lorsque vous commanderez des pièces.
Le numéro de série est gravé dans le cadre comme indiqué sur la figure.

Bestiller De reservedele så opgiv venligst maskinens fabrikationsnummer og eventuelt købsår. Det sparer Dem tid, penge og ærgrelser og os unødigt besvær.
De kan notere nummeret på Deres maskine her:

Nr..... Leveret den / 20.....
så har De det ved hånden, når De eventuelt skal bestille reservedele.
Fabrikationsnummeret findes indhugget i rammen, som vist på figuren.

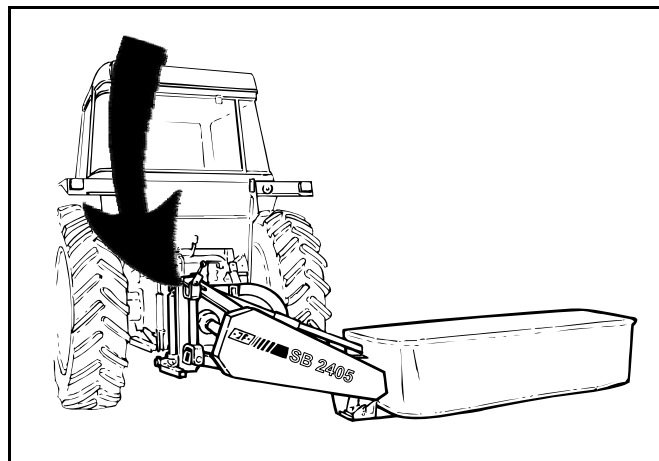

SPARE PARTS BOOK ERSATZTEILKATALOG CATALOGUE DE PIÈCES RESERVEDELSKATALOG

The book is divided into 5 passages:

1. Description of the spare part book.
2. Number key for assembly parts.
3. Number key showing on which figures the spare part numbers can be found.
4. Figure key showing on which figures the parts can be found.
5. Spare parts list.

Der Katalog ist in 5 Abschnitte eingeteilt:

1. Beschreibung des Ersatzteilkataloges.
2. Nummernschlüssel für Montagezubehör.
3. Nummernschlüssel mit Angabe der jeweiligen Ersatzteilnummer.
4. Figurliste mit Angabe, auf welche Figuren die Teile zu finden sind.
5. Ersatzteilliste.

Le catalogue est divisé en 5 sections:

1. Description du catalogue de pièces.
2. Liste de pièces de montage.
3. Numéros des pièces de rechange indiquant le numéro de figure.
4. Liste des figures indiquant sur quelle figure se trouvent les pièces.
5. Liste de pièces de rechange.

Kataloget er opdelt i 5 afsnit:

1. Beskrivelse af reservedelskataloget.
2. Nummernøgle for monteringsdele.
3. Nummernøgle - viser på hvilke figurer reservedelsnumrene findes.
4. Figurnøgle - viser på hvilke figurer delene findes.
5. Reservedelsliste.

**Description of the spare parts book:
Beschreibung des Ersatzteilkataloges:
Discription du catalogue de pièces:
Beskrivelse af reservedelskataloget:**

The spare parts book is built up as follows:

Fig. 01-29 Standard Fig. 50-59 Hub
Fig. 30-39 Gear Fig. 60-79 Variation of standard (Accessory)
Fig. 40-49 PTO drives Fig. 80- Accessory

Der Ersatzkatalog ist so aufgebaut:

Fig. 01-29 Standard Fig. 50-59 Nabe
Fig. 30-39 Getriebe Fig. 60-79 Variation vom Standard (Zubehör)
Fig. 40-49 Gelenkwellen Fig. 80- Zubehör

Le catalogue de pièces est arrangé comme suit:

Fig. 01-29 Standard Fig. 50-59 Moyeu
Fig. 30-39 Boîtier Fig. 60-79 Variation du standard (Accessoire)
Fig. 40-49 Arbres à cardan Fig. 80- Accessoire

Reservedelskataloget er opbygget således:

Fig. 01-29 Standard Fig. 50-59 Nav
Fig. 30-39 Gear Fig. 60-79 Variation af standard (Tilbehør)
Fig. 40-49 Kraftoverføringsaksler Fig. 80- Tilbehør

Quantity:

States quantity of parts for machine.
In connection with subassemblies:
Quantity for the assembly.

Anzahl:

Anzahl Teile je Maschine.
Bei Untersammlungen:
Anzahl je Sammlung.

Quantité:

Quantité de pièces par machine.
Pour les sous-assemblages: pièces
par assemblage.

Antal:

Antal dele pr. maskine.
Ved undersamlinger: dele pr. samling.

Position No.:

The position No. marked “()”
is not standard.
Is delivered as accessory.

Positionsnummer:

Die Positionsnummer, die mit “()”
gezeichnet ist, ist nicht der Standard.
Wird als Zubehör geliefert.

No de pos.:

Le numéro de position marqué d’un “()”
n’est pas une pièce standard.
Livrée comme accessoire.

Pos. nr.:

Positionsnummer mærket med “()”
er ikke standard.
Leveres som tilbehør

POS.	VARENUMMER	ANTAL	BENÆVNELSE	BEZEICHNUNG	DESIGNATION	HERTIL, DAZU TO THIS, A CECI
33.	1340-9153 T	2	KRYDS KREUTZGARNITUR >=0003219 <=0003448	CENTRE		1341-9187 1
33.1	1350-7005	2	KRYDS KREUTZGARNITUR >=0003219	CENTRE		1350-9052 4 1350-9104 1
34.	1340-0196	1	PROFILAKSEL PROFILGABEL >=0003219 <=0003448	PROFIL FORK		
34.1	1350-8008	1	PROFILAKSEL PROFILGABEL >=0003249	PROFIL FORK		

Article no.:

The article no. marked “T” is not
standard. Is delivered as accessories.
The article no. marked “+”:
Modification is being made.

Warennummer:

Ist eine Warennummer mit “T” ge-
kennzeichnet, wird sie als Zubehör
geliefert.
Eine Warennummer mit “+” ist als
Modifikation unterwegs.

No. D’article:

Le no d’article marqué d’un “T” n’est pas
un article standard. Livré comme
accessoire.
No. d’article marqué de “+”:
Une modification viendra.

Varenr.:

Varennummer mærket med “T” er ikke
standard. Leveres som tilbehør.
Varennummer mærket med “+”:
ændring undervejs.

Designation:

>=0003219 <=0003448
Spare part used for machine from
serial No. 3219 up to No. 3448 both
Nos. included.

Benennung:

>=0003219 <=0003448
Ersatzteil für Maschinen von
Fabrikationsnummer 3219 bis
Nr. 3448.

Désignation:

>=0003219 <=0003448
Pièce de rechange employée sur
machines à partir de no de série 3219
jusq’à et y compris no 3448.

Benævneelse:

>=0003219 <=0003448
Reservedel anvendt på maskine fra og
med fabrikationsnummer 3219 til
og med nr. 3448

To this:

States which and how many mounting
parts (screws, nuts, discs etc.)
are used with the spare part.
See under number key for assembly parts

Dazu:

Angabe von Montierungsteilen
(Schrauben, Muttern, Scheiben usw.)
die zusammen mit dem Ersatzteil
angewendet werden sollen. Siehe
Nummerschlüssel
für Montagezubehör.

Pour ceci:

Indique lesquelles et combien de
pièces de montage (vis, écrous, rondelles
etc.) sont employées avec la pièce de
rechange. Voir dans la liste de numéros
pour pièces de montage.

Hertil:

Angiver hvilke og hvor mange
monteringsdele (skruer, møtrikker, skiver
osv.) der anvendes sammen med reserve-
delen. Se under nummernøgle for
monteringsdele.

Acc Part No	Beskrivelse	Bezeichnung	Designation
811213-1126	STÅLSÆTSKRUE M6-16	ST. SETSCHRAUBE M6-16	STEEL SET SCREW M6-16
811213-2222	STÅLSÆTSKRUE M8-20	ST. SETSCHRAUBE M8-20	STEEL SET SCREW M8-20
811213-3222	STÅLSÆTSKRUE M10-20	ST. SETSCHRAUBE M10-20	STEEL SET SCREW M10-20
811213-3224	STÅLSÆTSKRUE M10-25	ST. SETSCHRAUBE M10-25	STEEL SET SCREW M10-25
811213-3225	STÅLSÆTSKRUE M10-25 KV. 10.9	ST. SETSCHRAUBE M10-25 Q.10.9	ST. SET SCREW M10-25 10.9
811213-4224	STÅLSÆTSKRUE M12-25	ST. SETSCHRAUBE M12-25	STEEL SET SCREW M12-25
811213-4324	STÅLSÆTSKRUE M12-35	ST. SETSCHRAUBE M12-35	STEEL SET SCREW M12-35
811213-6423	STÅLSÆTSKRUE M18-45 KVAL. 12,9	ST. SETSCHRAUBE M18-45 Q 12,9	STEEL SET SCREW M18-45 Q 12,9
811214-2326	STÅLSKRUE M8-80	STAHLSECHSKANTSCHR. M8-80	STEEL SCREW M8-80
811214-3226	STÅLSKRUE M10-60	STAHLSECHSKANTSCHRAUBE M10-60	STEEL SCREW M10-60
811214-3330	STÅLSKRUE M10-80	STAHLSECHSKANTSCHRAUBE M10-80	STEEL SCREW M10-80
811214-3430	STÅLSKRUE M10-130	STAHLSCHRAUBE M10-130	STEEL SCREW M10-130
811214-4223	STÅLSKRUE M12-55 KV 10.9	STAHLSCHRAUBE M12-55 Q. 10.9	STEEL SCREW M12-55 Q. 10.9
811214-4330	STÅLSKRUE M 12-90	STAHLSECHSKANTSCHRAUBE M 12-90	STEEL SCREW M 12-90
811214-5224	STÅLSKRUE M16-55	STAHLSECHSKANTSCHRAUBE M16-55	STEEL SCREW M16-55
811215-3222	BREDEDESKRUE M10-20 H-3	FLACHRUNDSCHRAUBE M10-20 H-3	CARRIAGE SCREW M10-20 H-3
811215-3226	BREDEDESKRUE M10-25 KVAL.8,8	FLACHRUNDSCHRAUBE M10-25 Q 8,8	CARRIAGE SCREW M10-25 Q 8,8
811215-3228	BREDEDESKRUE M10-20 KV 8.8	FLACHRUNDSCHRAUBE M10-20 Q 8,8	CARRIAGE SCREW M10-20 Q 8,8
811215-3320	BREDEDESKRUE M10-30 KV 8.8	FLACHRUNDSCHRAUBE M10-30 Q 8.8	CARRIAGE SCREW M10-30 Q 8.8
811219-0210	SKRUE M10-30 12.9 DELTA B	SCHRAUBE M10-30 12.9 DELTA B	SCREW M10-30 12.9 DELTA B
811219-0237	UNBRACOSKRUE M12-35 U/S	INNENSECHSK SCHR M12-35 VERS	ALLEN SCREW M12-35 C-SUNK
811219-0526	PLOVSKRUE M10-25	PFLUGSCHRAUBE M10-25	PLOUGH SCREW M10-25
811219-0809	KNIVBOLT M12 KV. 10.9	MESSERBOLZEN M12 Q. 10.9	KNIFE BOLT M12 Q. 10.9
811220-2321	NYLOC MØTRIK M8	NYLOC MUTTER M8	NYLOC NUT M8
811220-3122	STÅLMØTRIK M10	STAHLMUTTER M10	STEEL NUT M10
811220-3321	NYLOC MØTRIK M10	NYLOC MUTTER M10	NYLOC NUT M10
811220-3323	NYLOC MØTRIK M10 KVAL 10.9	NYLOC MUTTER M10 Q. 10.9	NYLOC NUT M10 Q. 10.9
811220-3922	MØTRIK M10	MUTTER M10	NUT M10
811220-4321	NYLOC MØTRIK M12	NYLOC MUTTER M12	NYLOC NUT M12
811220-4323	NYLOC MØTRIK M12 KV 10	NYLOC MUTTER M12 Q 10	NYLOC NUT M12 Q 10
811220-5321	NYLOC MØTRIK M16	NYLOC MUTTER M16	NYLOC NUT M16
811220-6321	NYLOC MØTRIK M20	NYLOC MUTTER M20	NYLOC NUT M20
811241-1202	SPÆNDESKIVE 8,4-16-1,6	SCHEIBE 8,4-16-1,6	WASHER 8,4-16-1,6
811241-1502	SPÆNDESKIVE 8,5-30-3	SCHEIBE 8,5-30-3	WASHER 8,5-30-3
811241-2308	SPÆNDESKIVE 11,5-23-1,5	SCHEIBE 11,5-23-1,5	WASHER 11,5-23-1,5
811241-2402	SPÆNDESKIVE 10,5-20-2,0	SCHEIBE 10,5-20-2,0	WASHER 10,5-20-2,0
811241-2407	SKIVE 13-20-2	SCHEIBE 13-20-2	WASHER 13-20-2
811241-2504	SPÆNDESKIVE 11,5-30-3	SCHEIBE 11,5-30-3	WASHER 11,5-30-3
811241-3403	SPÆNDESKIVE 13-25-2,5	SCHEIBE 13-25-2,5	WASHER 13-25-2,5
811241-3702	SPÆNDESKIVE 13-35-5 HERDET	SCHEIBE 13-35-5GEHAERTET	WASHER 13-35-5HARDENED
811241-4503	SPÆNDESKIVE 17,5-35-3	SCHEIBE 17,5-35-3	WASHER 17,5-35-3
811241-5301	SPÆNDESKIVE 20,2-34-1,5	SCHEIBE 20,2-34-1,5	WASHER 20,2-34-1,5
811241-5503	SPÆNDESKIVE 21,0-42-3,5	SCHEIBE 21,0-42-3,5	WASHER 21.0-42-3.5
811241-6409	SPÆNDESKIVE 25,5-39-2,5	SCHEIBE 25,5-39-2,5	WASHER 25,5-39-2,5
811241-9202	SPÆNDESKIVE 40,1-51-1,5	SCHEIBE 40,1-51-1,5	WASHER 40,1-51-1,5
811241-9916	PASSKIVE 45-66-1,0	SCHEIBE 45-66-1,0	WASHER 45-66-1,0
811241-9917	PASSKIVE 45-56-0.5	SCHEIBE 45-56-0.5	WASHER 45-56-0.5
811242-3221	FJEDERSKIVE M10	FEDERSCHEIBE M10	SPRING WASHER M10
811251-1201	SPÆNDESTIFT 3,5-30	SPANNSTIFT 3,5-30	SPECIAL PIN 3,5-30
811251-3201	SPÆNDESTIFT 5-30	SPANNSTIFT 5-30	SPECIAL PIN 5-30
811251-4103	SPÆNDESTIFT 6-24	SPANNSTIFT 6-24	SPECIAL PIN 6-24
811251-5301	SPÆNDESTIFT 7-40	SPANNSTIFT 7-40	SPECIAL PIN 7-40
811251-5602	SPÆNDESTIFT 8-70	SPANNSTIFT 8-70	SPECIAL PIN 8-70
811251-6301	SPÆNDESTIFT 10-40	SPANNSTIFT 10-40	SPECIAL PIN 10-40
811251-6302	SPÆNDESTIFT 10-45	SPANNSTIFT 10-45	SPECIAL PIN 10-45
811251-6402	SPÆNDESTIFT 10-55	SPANNSTIFT 10-55	SPECIAL PIN 10-55
811251-7602	SPÆNDESTIFT 13-70	SPANNSTIFT 13-70	SPECIAL PIN 13-70
811251-8301	SPÆNDESTIFT 15-40	SPANNSTIFT 15-40	SPECIAL PIN 15-40
811252-4102	SPLIT 5-25	SPLINT 5-25	COTTER PIN 5-25
811254-3201	SIKRINGSSPLIT 8 MM	FEDERSPLINT 8 MM	SECURING PIN 8 MM
811254-4201	SIKRINGSSPLIT 10 MM	FEDERSPLINT 10 MM	SECURING PIN 10 MM
811255-4201	LÅSERING 40 MM UDVENDIG	SICHERUNGSRING 40 MM AUSSEN	SNAP RING 40 MM OUTER
811313-2101	SMØRENIPPEL	SCHMIERNIPPEL	GREASE NIPPLE
811335-5514	LEJE	LAGER	BEARING
811433-0292	LÅSEFJEDER	SPERRFEDER	LOCKING SPRING
811434-0101	TALLERKENFJEDER 28-10,2-1	TELLERFEDER 28-10,2-1	DISC SPRING 28-10,2-1

Part number	FigRev.	Pos. Rev.	Part number	Fig. Rev.	Pos.Rev.	Part number	Fig. Rev.	Pos. Rev.
811165-0189	005	014	811165-0189	080	009	811214-5426	001	035
811219-0208	004	009	811219-0210	004	008	811219-0220	005	013
811219-0220	080	010	811219-0227	004	011	811220-2122	004	024
811220-4122	001	010	811220-4127	004	007	811220-5321	001	040
811241-4503	001	039	811255-3202	030	014	811255-4102	005	009
811255-4102	080	005	811255-4201	002	037	811255-4204	004	032
811255-7102	004	031	811255-7102	030	002	811311-2601	002	027
811311-8401	002	031	811311-8406	002	024	811311-8535	002	023
811315-9116	030	020	811315-9118	030	019	811315-9140	030	004
811315-9264	030	009	811315-9265	030	016	811315-9266	030	011
811315-9267	030	013	811315-9268	030	012	811315-9271	030	003
811315-9274	030	010	811315-9298	030	017	811315-9671	004	027
811315-9693	030	005	811315-9694	030	007	811315-9695	030	008
811315-9697	004	006	811315-9698	030	018	811315-9720	030	015
811317-0302	002	030	811317-0435	002	033	811317-0442	002	026
811317-0715	002	029	811317-9269	002	099	811317-9808	001	098
811331-2303	005	010	811331-2303	080	006	811331-3304	002	006
811331-4102	030	001	811331-9909	030	006	811338-0105	002	012
811338-0109	002	020	811343-0405	006	008	811350-0054	041	000
811350-0061	040	000	811350-2102	040	002	811350-2102	041	002
811350-2103	041	097	811350-2115	040	097	811350-9001	040	051
811362-1016	002	035	811380-0013	006	005	811380-2205	004	000
811392-0110	001	019	811393-0109	001	030	811393-0138	002	028
811399-0121	002	021	811399-0124	002	022	811399-0154	001	027
811431-3298	001	025	811431-4699	001	038	811432-5695	001	018
811433-0312	003	004	811434-0108	004	044	812010-394X	002	025
812081-059X	002	013	812081-332X	001	003	812081-397X	001	011
812081-398X	001	044	812081-399X	001	021	812082-020X	002	010
812082-040X	001	034	812082-045X	001	026	812082-069B	001	012
812082-085X	002	007	812082-091X	002	034	812082-130X	002	009
812082-133X	001	032	812082-144X	002	015	812082-164X	005	022
812082-248X	002	003	812082-331X	002	004	812082-332X	002	001
812082-333X	001	014	812082-335X	002	002	812082-411X	002	019
812082-412X	002	017	812082-417X	001	020	812082-423X	002	005
812082-430X	001	024	812082-438X	001	016	812082-439X	001	013
812082-440X	002	018	812082-464X	001	022	812082-490X	005	003
812082-491X	005	002	812082-492X	005	004	812082-493X	005	001
812085-703X	006	007	812085-704X	006	002	812085-706X	004	041
812085-707X	004	042	812085-708X	004	047	812085-709X	004	043
812085-710X	004	045	812085-711X	004	046	812085-712X	004	048
812085-714X	004	049	812085-715X	004	050	812085-716X	004	051
812085-717X	004	013	812085-718X	004	019	812085-719X	004	014
812085-720X	004	015	812085-721X	004	016	812085-722X	004	017
812085-723X	004	020	812085-724X	004	018	812085-725X	004	028
812085-726X	004	029	812085-727X	004	030	812085-728X	004	033
812085-729X	004	010	812085-731X	004	026	812085-732X	004	012
812085-733X	004	021	812085-734X	004	023	812085-735X	004	022
812085-736X	004	003	812085-744X	004	025	812088-560X	005	019
812088-561X	005	015	812089-180X	006	003	812114-175X	003	006
812184-229X	001	009	812221-109X	001	023	812223-220X	001	031
812223-268X	001	008	812225-092X	001	041	812228-465X	001	015
812279-023X	005	012	812279-023X	080	008	812279-153X	001	043
812279-221X	005	007	812279-221X	080	003	812279-223X	005	008
812279-223X	080	004	812320-830X	001	017	812320-831X	002	016
812320-928B	003	005	812506-161X	002	036	813081-367X	003	007
813081-377X	002	011	813081-395X	001	001	813081-411X	001	036
813082-002C	001	006	813082-012A	001	028	813082-019X	002	008
813082-046A	001	005	813082-161X	005	005	813082-162X	005	006
813082-165X	005	023	813082-312X	006	009	813082-313X	003	008
813082-329X	001	004	813082-381X	001	002	813082-410X	005	011
813082-410X	080	007	813082-414X	001	033	813082-431X	080	002
813082-494X	003	001	813082-497X	003	002	813082-514X	003	003
813085-705X	004	004	813085-730X	004	005	813085-730X	030	000
813085-745X	004	001	813088-546X	005	018	813088-549X	005	020
813088-551X	005	016	813088-554X	005	017	813088-557X	005	021
813088-584X	005	024	813088-585X	005	025	813088-588X	006	001
813214-724X	006	006	813214-725X	006	004	813223-192A	001	037
813224-089X	001	029	813225-087X	001	042	813225-596X	002	014
813890-116X	001	099	814080-8025	080	001			

Fig. 1

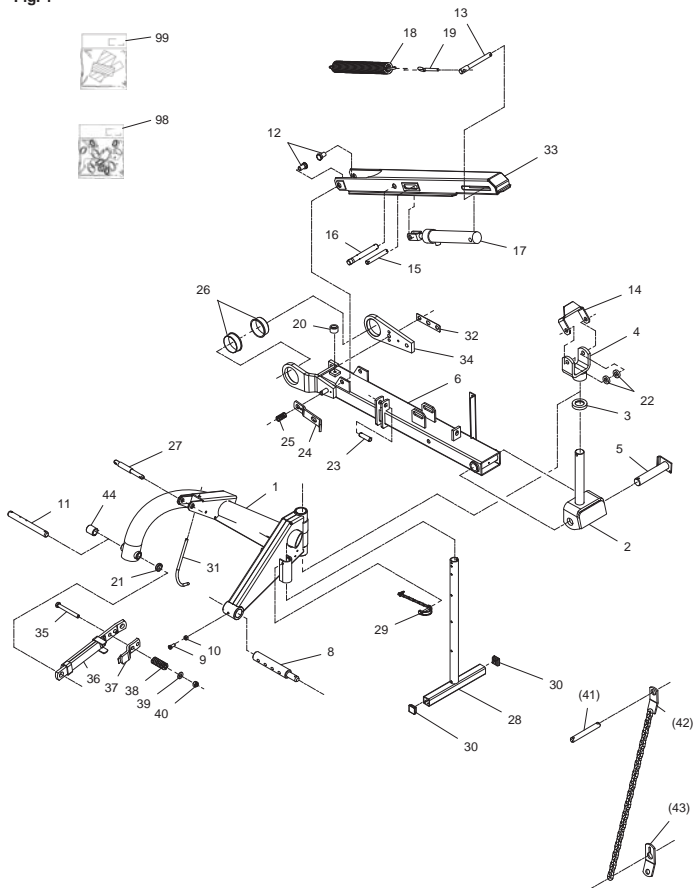

Fig. 2

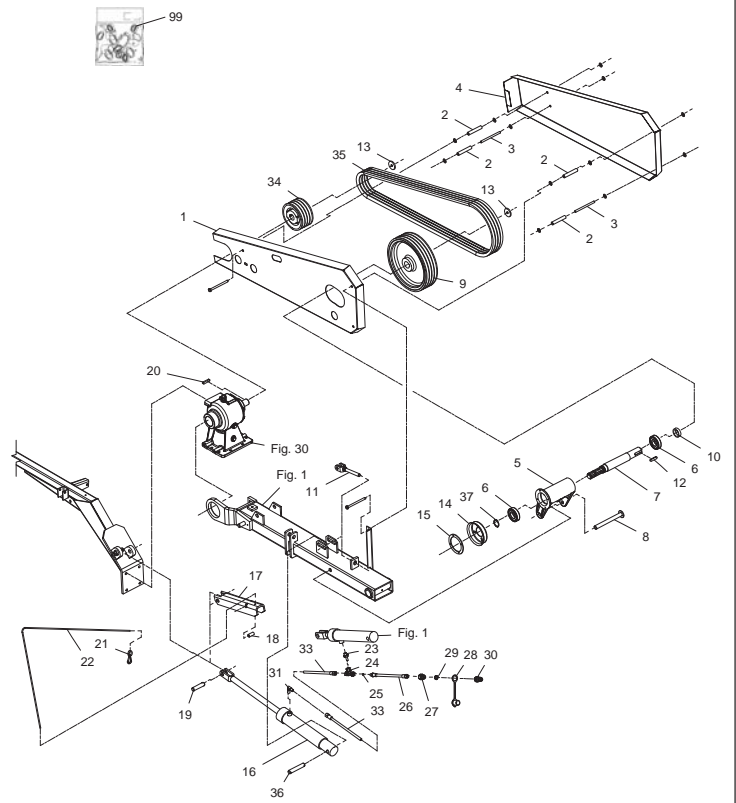

Fig. 3

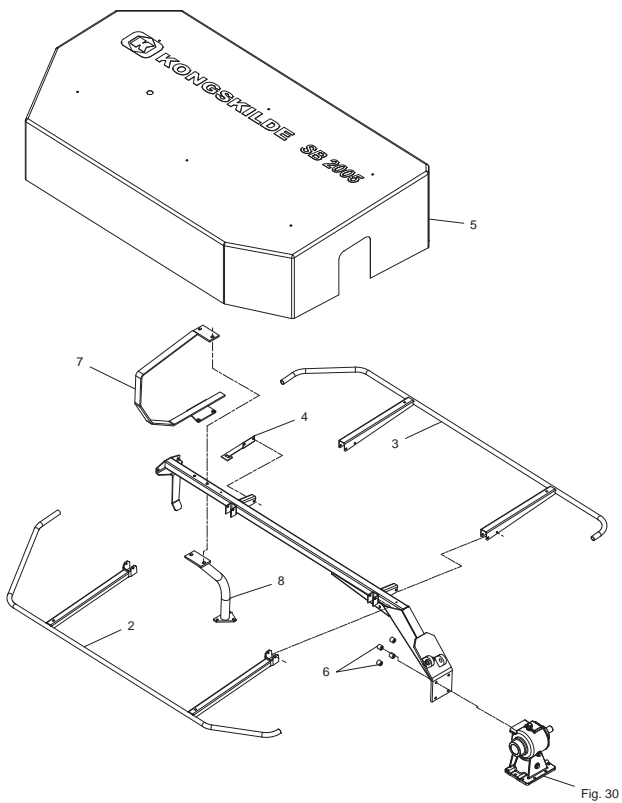

Fig. 4

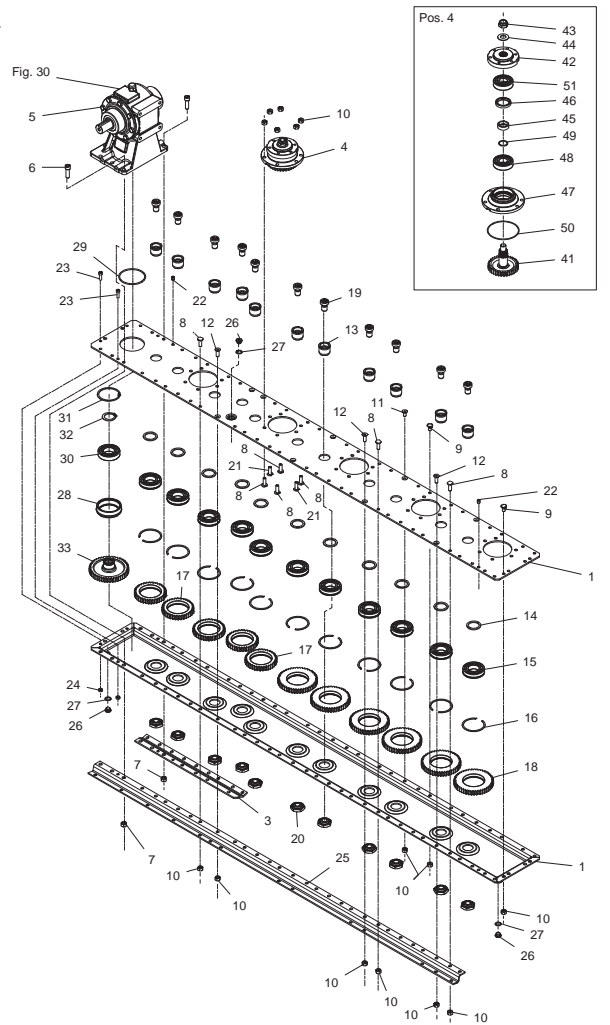

Fig. 5

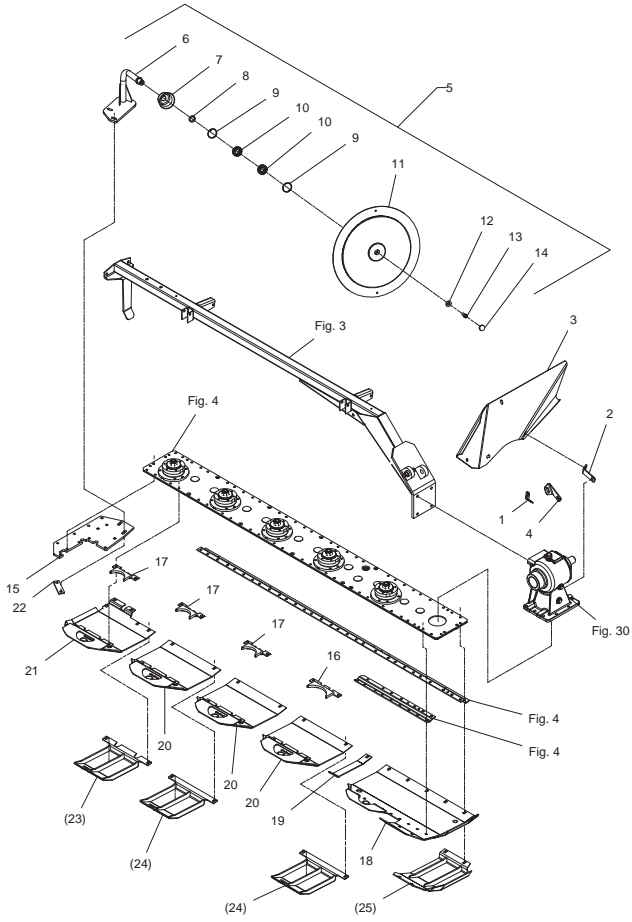

Fig. 6

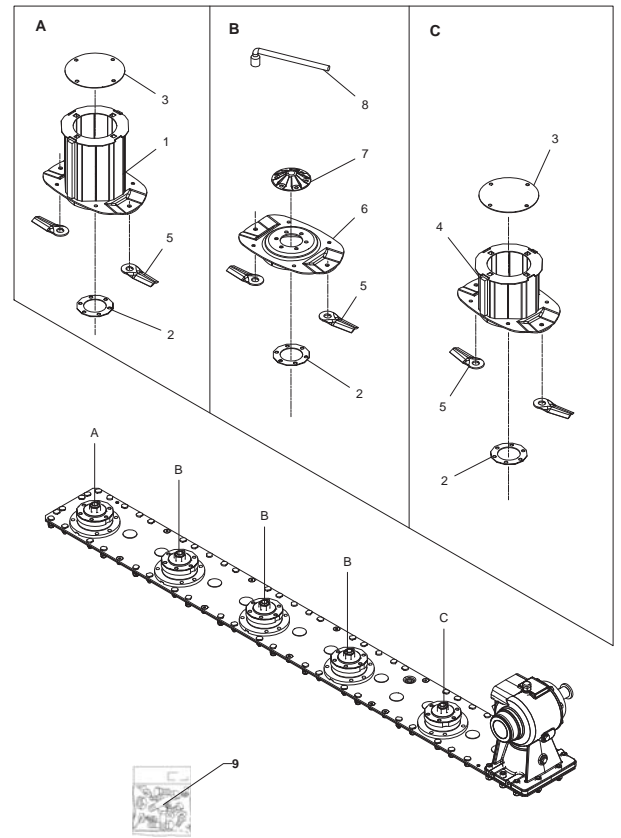

Fig. 30

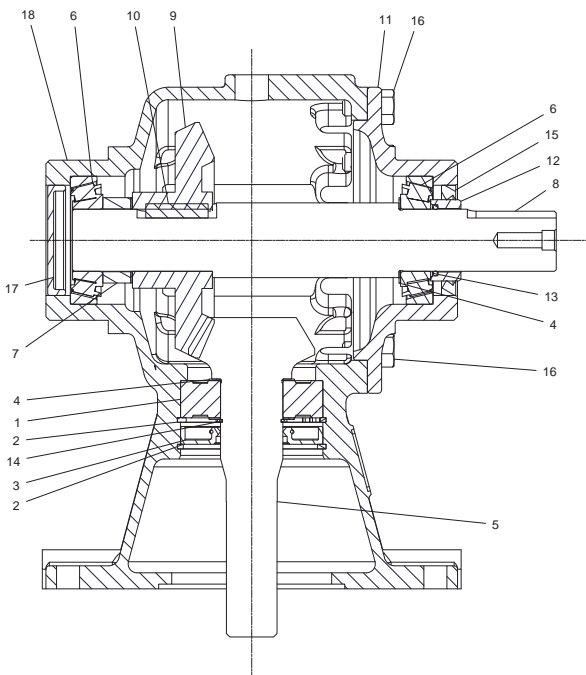

Fig. 40

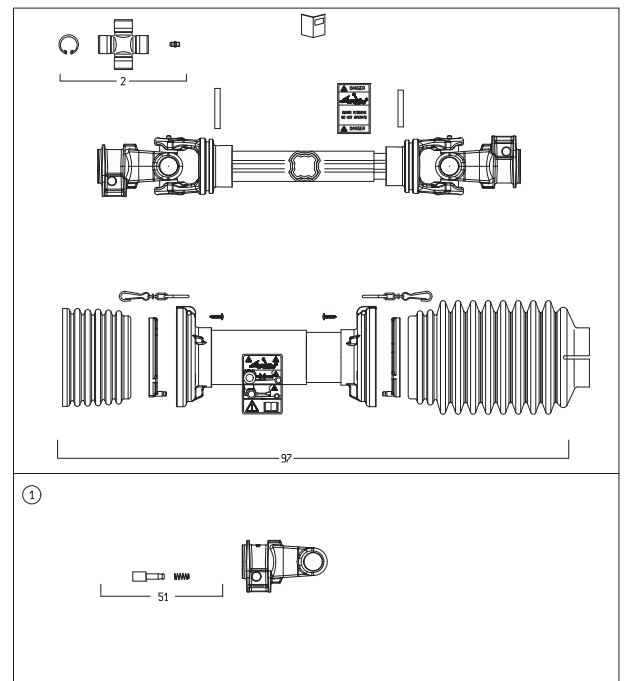

Fig. 41

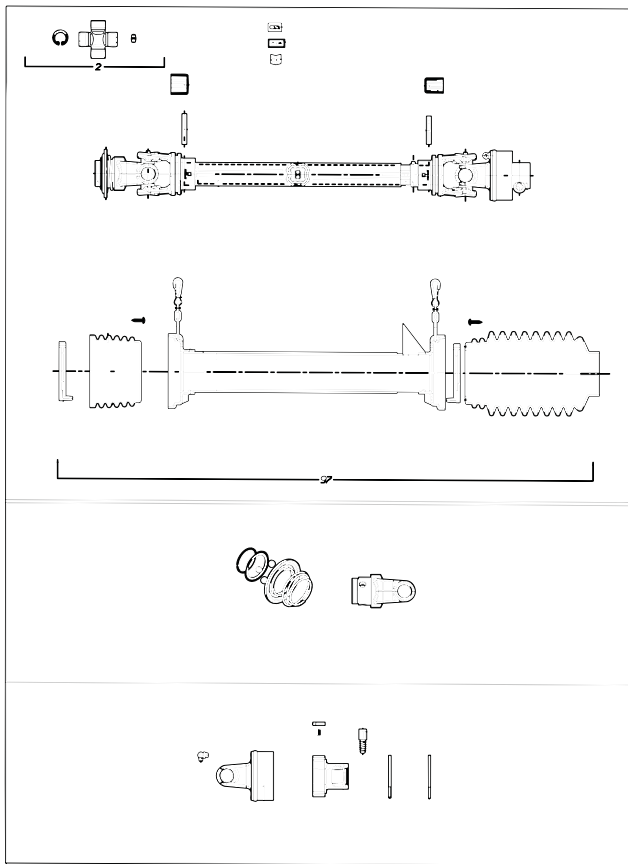

Fig. 80

Tilbehør - Zubehör - Accessories

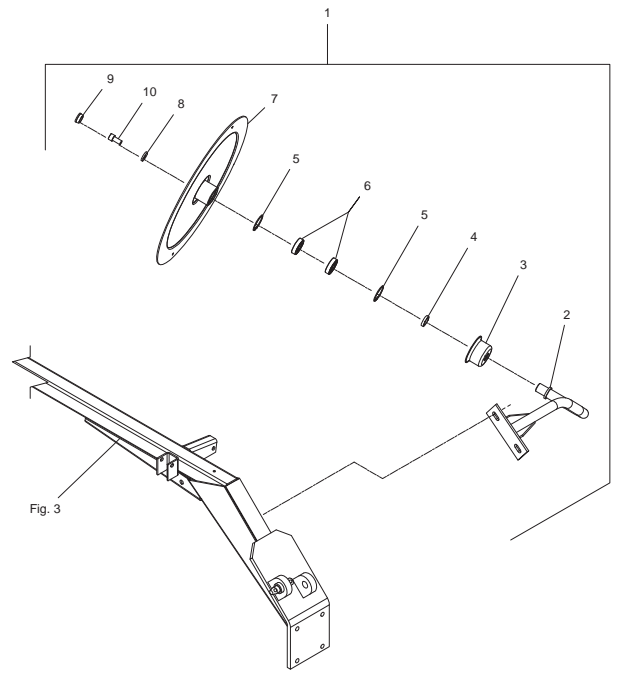
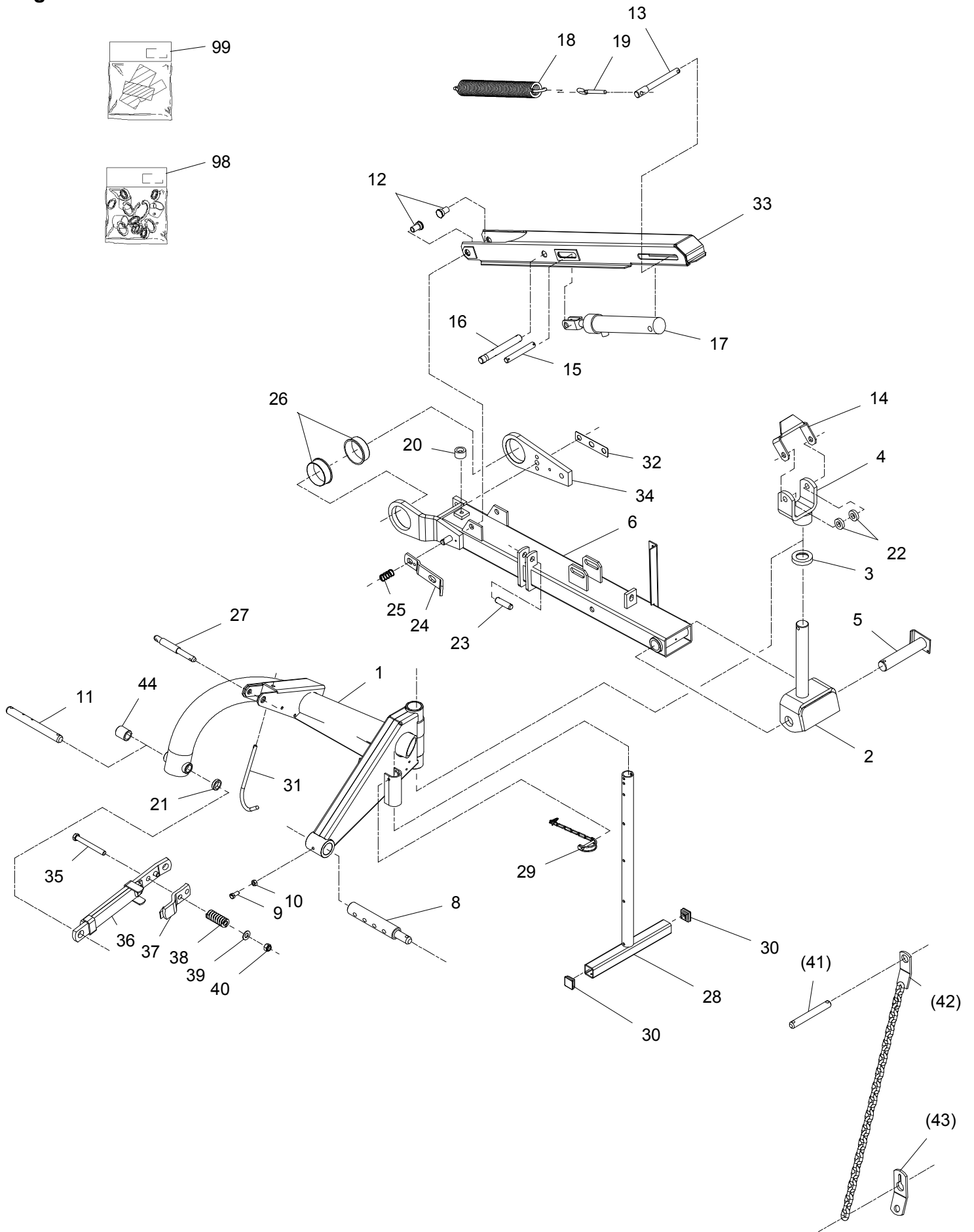
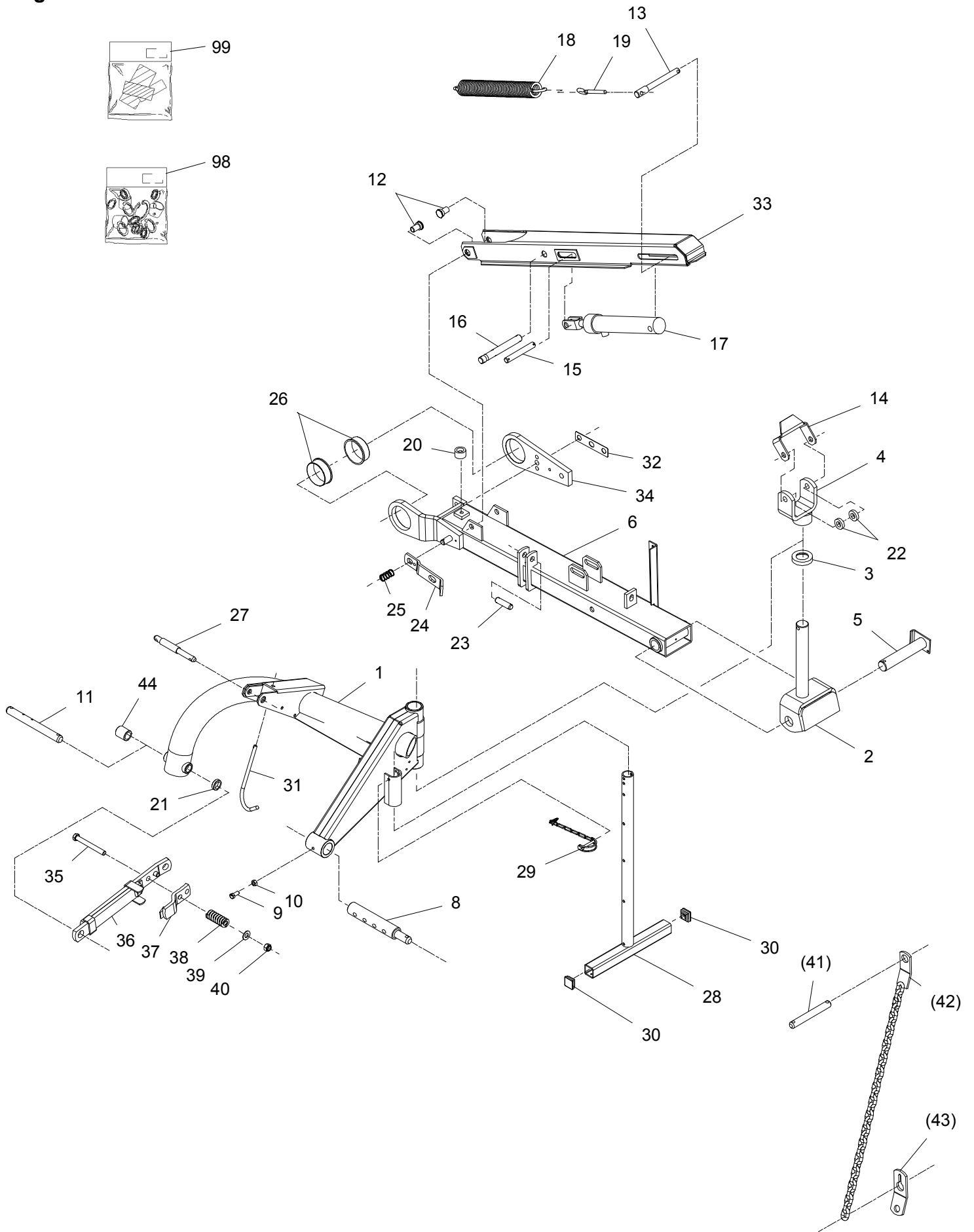

Fig. 1



SB-0016/2		SB 2005		Figure No	001	>=B029040171108	Hertil, Dazu To this, A ceci	
Position No	Spare Part No	Qty	Beskrivelse	Designation		Acc Part No	Qty	
001	813081-395X	1	TOPRAMME ZUGRAHMEN	TOP FRAME		811254-4201	1	
						811313-2101	1	
						811335-5514	2	
002	813082-381X	1	OPHÆNGNINGSGAFFEL AUFHAENGUNGSGABEL	SUSPENSION FORK		811241-9916	2	
						811241-9917	1	
003	812081-332X	1	AFSTANDSRING DISTANZRING	SPACER				
004	813082-329X	1	GAFFEL GABEL	FORK		811251-5602	1	
						811251-7602	1	
005	813082-046A	1	TAP ZAPFEN	DOWEL		811241-9202	2	
						811251-6402	1	
006	813082-002C	1	UDLIGGERBOM AUSLEGER	BOOM		811313-2101	1	
008	812223-268X	1	TAP ZAPFEN	DOWEL				
009	812184-229X	1	BOLT BOLZEN	BOLT				
010	811220-4122	1	STÅLMØTRIK M12 STAHLMUTTER M12	STEEL NUT M12				
011	812081-397X	1	TAP ZAPFEN	DOWEL		811251-5301	1	
						811254-4201	2	
012	812082-069B	2	BOLT BOLZEN	BOLT		811220-6321	1	
013	812082-439X	1	TAP ZAPFEN	DOWEL		811241-5503	1	
						811251-6301	1	
014	812082-333X	1	PARKERINGSLÅS PARKIERUNGSSCHLOSS	PARKING LOCK				
015	812228-465X	1	TAP ZAPFEN	DOWEL		811241-5503	2	
						811251-3201	2	
016	812082-438X	1	TAP ZAPFEN	DOWEL		811241-6409	4	
						811251-6302	3	
017	812320-830X	1	CYLINDER ZYLINDER	CYLINDER				
018	811432-5695	1	TRÆKFJEDER DM48 T9 ZUGFEDER DM48 T9	TENSION SPRING DM48 T9				
019	811392-0110	1	ØJEBOLT M12-123 AUGENBOLZEN M12-123	EYE BOLT M12-123				
020	812082-417X	1	STOP STOPP	STOP		811219-0237	1	
021	812081-399X	1	RING RING	RING				
022	812082-464X	2	BØSNING BUCHSE	BUSH				
023	812221-109X	1	TAP ZAPFEN	DOWEL		811251-5301	2	

Fig. 1



SB-0016/2		SB 2005		Figure No	001	>=B029040171108	Hertil, Dazu	
Position No		Spare Part No	Qty	Beskrivelse		Designation	To this, A ceci	
							Acc Part No	Qty
024	812082-430X	1	TRANSPORTLÅS TRANSPORTSCHLOSS		TRANSPORT LOCK		811241-5503	1
							811251-1201	1
							811251-4103	1
							811254-3201	1
025	811431-3298	1	TRYKFJEDER DRUCKFEDER		COMPRESSION SPRING			
026	812082-045X	2	BØSNING BUECHSE		BUSH			
027	811399-0154	1	TOPBOLT STECKBOLZEN		TOP BOLT			
028	813082-012A	1	STØTTEFOD STUETZE		SUPPORT		811433-0292	1
029	813224-089X	1	KÆDE MED SPLIT KETTE MIT SPLINTE		CHAIN WITH PIN			
030	811393-0109	2	PLAST-DUPSKO PLASTIKSPITZE		PLASTIC TIP			
031	812223-220X	1	BØJLE BUEGEL		HOOP		811241-3403	1
							811252-4102	1
032	812082-133X	1	LÅSEBLIK SCHLIESSBLECH		NAB		811213-6423	2
033	813082-414X	1	AFLASTER ENTLASTUNG		SUSPENSION		811220-4321	1
							811241-3403	1
034	812082-040X	1	LEJEPLADE LAGERPLATTE		BEARING PLATE		811251-8301	2
035	811214-5426	1	STÅLSKRUE M16-140 STAHLSECHSKANTSCHRAUBE M16-140		STEEL SCREW M16-140			
036	813081-411X	1	UDLØSER AUSLOESER		RELEASE			
037	813223-192A	1	LÅS KLINKE		LOCK			
038	811431-4699	1	TRYKFJEDER DRUCKFEDER		COMPRESSION SPRING			
039	811241-4503	1	SPÆNDESKIVE 17,5-35-3 SCHEIBE 17,5-35-3		WASHER 17,5-35-3			
040	811220-5321	1	NYLOC MØTRIK M16 NYLOC MUTTER M16		NYLOC NUT M16			
041	812225-092X	T 1	TAP ZAPFEN		DOWEL			
042	813225-087X	T 1	HOLDEKÆDE HALTEKETTE		SUPPORT CHAIN		811254-4201	1
043	812279-153X	T 1	SPÆNDESTYKKE SPANNSTUECK		TIGHTENING PIECE		811254-4201	1
044	812081-398X	1	BØSNING BUCHSE		BUSH			
098	811317-9808	1	PAKNINGSSÆT DICHTUNGSSATZ		SET OF GASKETS			
099	813890-116X	1	KLISTERMÆRKER SB AUFKLEBER SB		TRANSFER SB			

Fig. 2

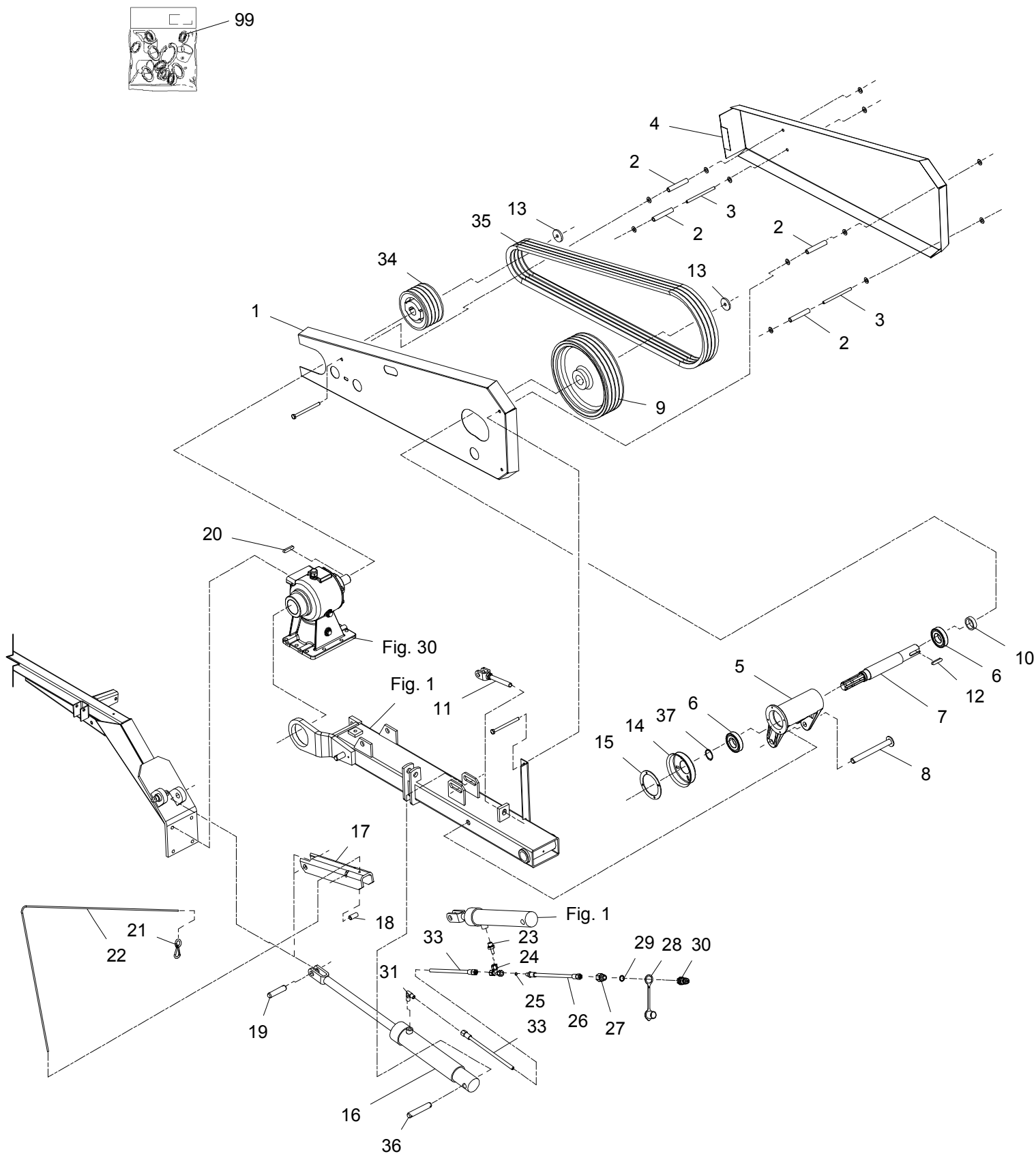

SB-0016/2		SB 2005		Figure No	002	>=B029040171108	Hertil, Dazu To this, A ceci		
Position No	Spare Part No	Qty	Beskrivelse	Designation		Acc	Part No	Qty	
001	812082-332X	1	SKÆRM SCHUTZ	GUARD					
002	812082-335X	4	AFSTANDSRØR ABSTANDROHR	DISTANCE TUBE		811214-3430		1	
						811220-3122		1	
						811241-2308		2	
003	812082-248X	2	SKÆRMBOLT BOLZEN	BOLT		811220-3122		1	
						811220-3321		1	
						811241-2308		4	
004	812082-331X	1	SKÆRM SCHUTZ	GUARD		811220-3321		4	
						811241-2504		4	
005	812082-423X	1	LEJEHUS LAGERGEHAEUSE	BEARING HOUSING					
006	811331-3304	2	KUGLELEJE 6208 2RS KUGELLAGER 6208 2RS	BALL BEARING 6208 2RS					
007	812082-085X	1	AKSEL WELLE	SHAFT		811255-4201		2	
008	813082-019X	1	LEJEBOLT LAGERBOLZEN	BEARING BOLT		811241-5301		2	
						811241-5503		6	
						811251-3201		1	
009	812082-130X	1	KILEREMSKIVE KEILRIEMENSCHIEBE	PULLEY					
010	812082-020X	1	AFSTANDSRING DISTANZRING	DISTANCE RING					
011	813081-377X	1	STRAMMEBOLT SPANNBOLZEN	TIGHTENING BOLT		811214-5224		1	
						811220-5321		2	
						811241-4503		1	
012	811338-0105	1	PASFEDER 12-8-48 FEDERKEIL 12-8-48	FLAT KEY 12-8-48					
013	812081-059X	2	SKIVE SCHEIBE	WASHER		811213-3225		1	
						811242-3221		1	
014	813225-596X	1	HOLDER HALTER	HOLDER					
015	812082-144X	1	HOLDER HALTER	HOLDER		811213-1126		4	
016	812320-831X	1	CYLINDER ZYLINDER	CYLINDER					
017	812082-412X	1	STOP STOPP	STOP					
018	812082-440X	1	RØR ROHR	TUBE		811214-2326		1	
						811220-2321		1	
						811241-1202		2	
019	812082-411X	1	TAP ZAPFEN	DOWEL		811241-5301		2	
						811251-3201		2	
020	811338-0109	1	PASFEDER 10-8-50 FEDERKEIL 10-8-50	FLAT KEY 10-8-50					
021	811399-0121	1	KARABINHAGE KARABINHAKEN	SNAP HOOK					
022	811399-0124	1	SNOR 1M SCHNUR 1M	STRING 1M					

Fig. 2

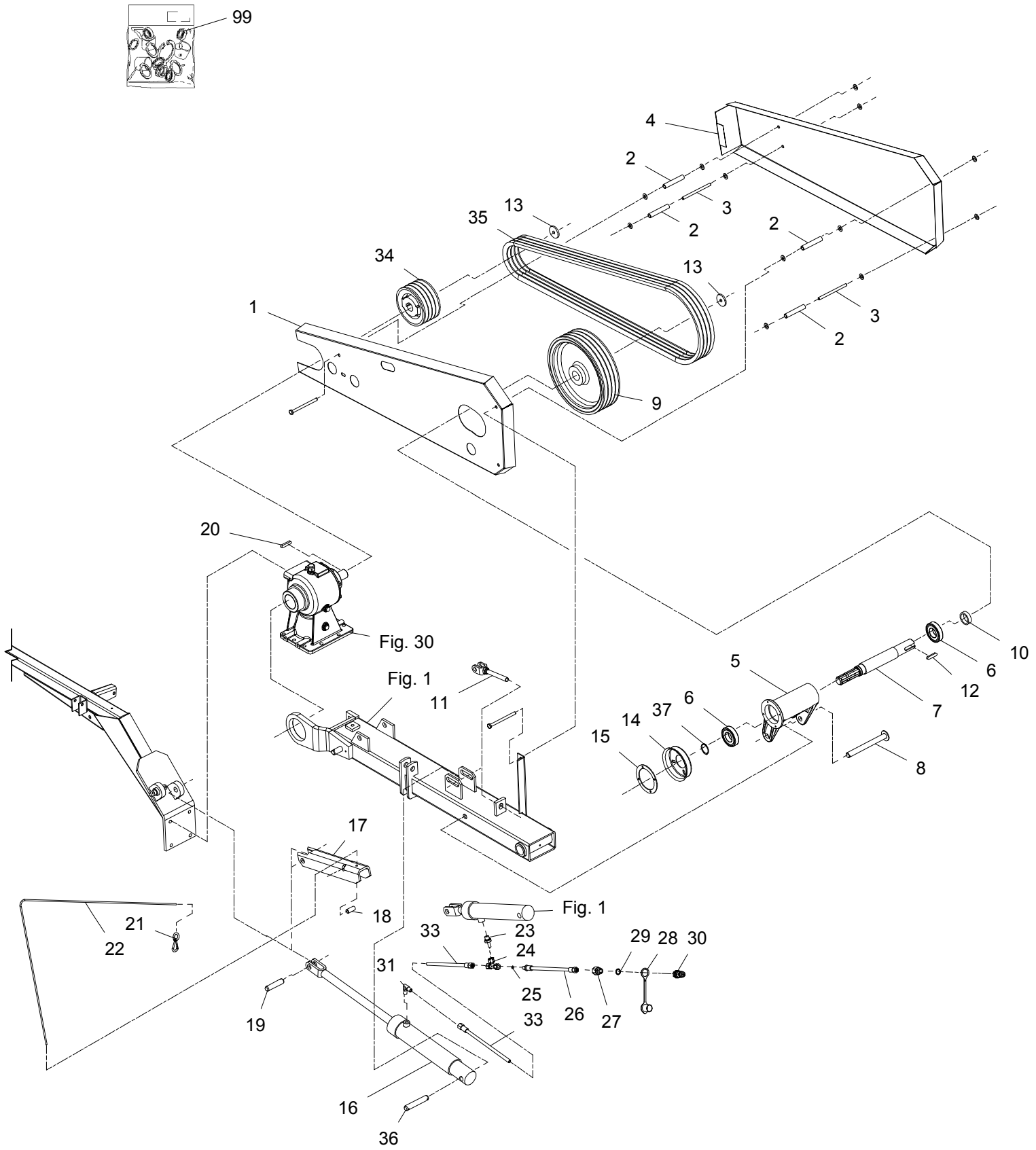

SB-0016/2		SB 2005	Figure No 002	>=B029040171108	Hertil, Dazu To this, A ceci		
Position No	Spare Part No	Qty	Beskrivelse	Designation	Acc Part No	Qty	
023	811311-8535	1	RØRSTUDS ROHRSTUTZEN	PIPE STUB			
024	811311-8406	1	T-STYKKE T-STUECK	T-PIECE			
025	812010-394X	1	DYSE DÜSE	NOZZLE			
026	811317-0442	1	HYDRAULIKSLANGE L=2000 HYDRAULIKSCHLAUCH L=2000	HYDRAULIC HOSE L=2000			
027	811311-2601	1	NIPPELMUFFE NIPPEL	BUSHING			
028	811393-0138	1	BESKYTTELSHÆTTE GUL SCHUTZKAPPE GELB	PROTECTION CAP YELLOW			
029	811317-0715	1	O-RING O-RING	O-RING			
030	811317-0302	1	STIK F/LYNKOBLING ANSCHLUSS F/SCHNELLKUPPLUNG	CONNECTION F/QUICK-COUPLING			
031	811311-8401	1	VINKELFORSKRUNING WINKELVERSCHRAUBUNG	ANGLE COUPLING			
033	811317-0435	2	HYDRAULIKSLANGE L=1100 HYDRAULIKSCHLAUCH L=1100	HYDRAULIC HOSE L=1100			
034	812082-091X	1	KILREMSKIVE 4-B 150 KEILRIEMENSCHLEIBE 4-B 150	PULLEY 4-B 150			
035	811362-1016	1	REMSÆT (4 STK.) RIEMENSATZ (4 STCK)	V-BELT SET (4 PCS)			
036	812506-161X	1	TAP ZAPFEN	DOWEL	811241-5301	2	
					811251-3201	2	
037	811255-4201	1	LÅSERING 40 MM UDVENDIG SICHERUNGSRING 40 MM AUSSEN	SNAP RING 40 MM OUTER			
099	811317-9269	1	PAKNINGSSÆT DICHTUNGSSATZ	SET OF GASKETS			

Fig. 3

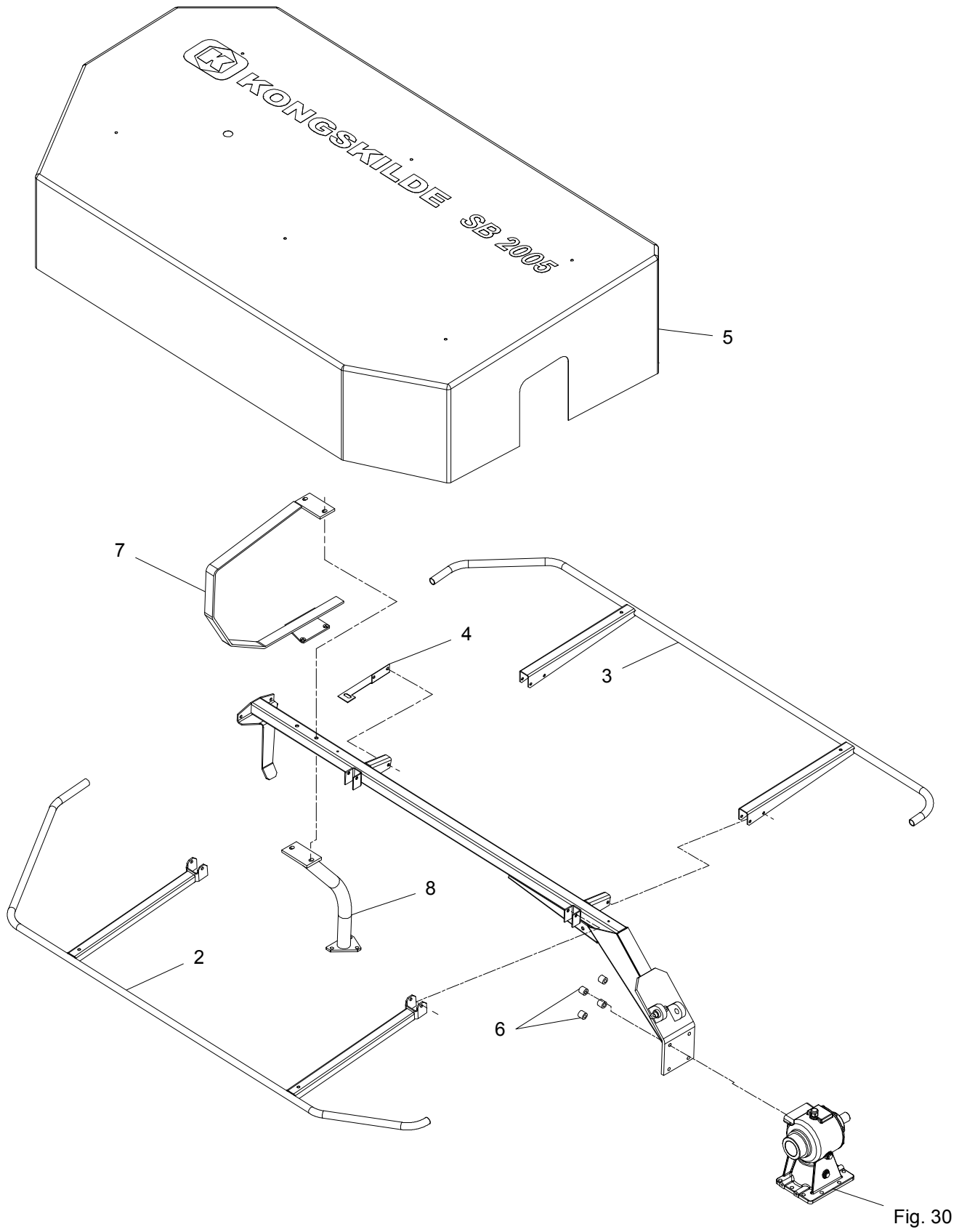

SB-0016/2		SB 2005		Figure No	003	>=B029040171108	Hertil, Dazu To this, A ceci		
Position No	Spare Part No	Qty	Beskrivelse	Designation		Acc	Part No	Qty	
001	813082-494X	1	UDLIGGER F. SB 2005 AUSLEGER F. SB 2005	BOOM F. SB 2005					
002	813082-497X	1	BØJLE, FORREST BÜGEL, VORNE	HOOP, FRONT		811214-3330		3	
						811220-3321		3	
						811434-0101		12	
003	813082-514X	1	BØJLE, BAGERSTE BÜGEL, HINTERE	HOOP, REAR		811214-3226		6	
						811220-3321		6	
004	811433-0312	1	LÅSEFJEDER SCHLOSSFEDER	RETAINING SPRING					
005	812320-928B	1	DUG TUCH	CANVAS		811213-2222		2	
						811241-1502		2	
006	812114-175X	4	BØSNING BUCHSE	BUSH		811214-4223		1	
007	813081-367X	T 1	STRÅSKILLERBØJLE BUEGEL	HOOP		811219-0526		2	
						811220-3321		2	
008	813082-313X	T 1	AFSTIVNING ABSTEIFUNG	SUPPORT		811213-4324		3	
						811214-4330		2	
						811220-4321		5	
						811241-2407		5	

Fig. 4

Fig. 30

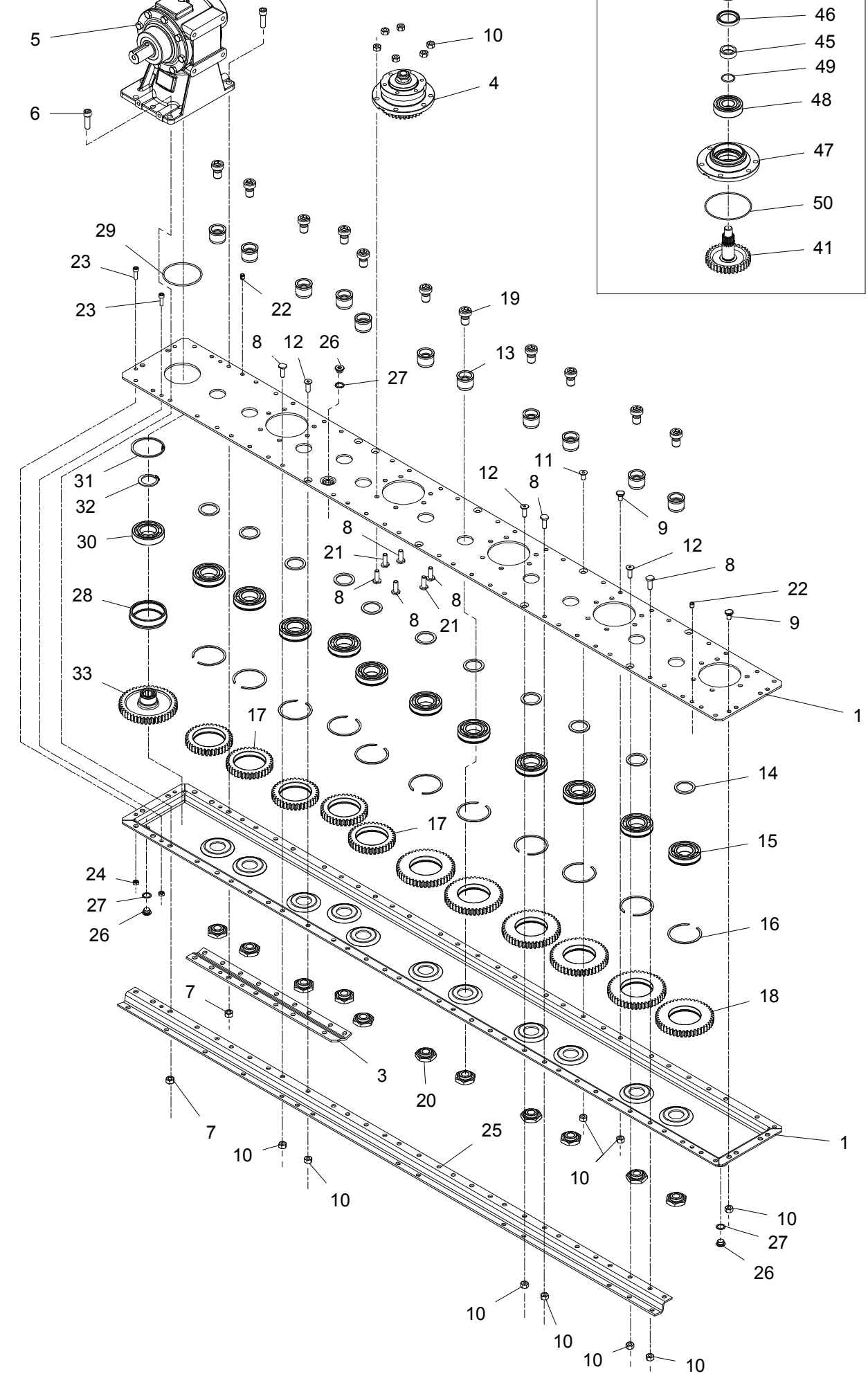

SB-0016/2		SB 2005	Figure No 004	>=B029040171108	Hertil, Dazu To this, A ceci
Position No	Spare Part No	Qty	Beskrivelse	Designation	Acc Part No Qty
000	811380-2205	1	KNIVBJÆLKE 5 SK MÄHBALKEN 5 SCH	CUTTERBAR 5 DSC	
001	813085-745X	1	KNIVBJÆLKE SCHNITTBALKEN	CUTTERBAR	
003	812085-736X	1	FORSTÆRKNING VERSTÄRKERUNG	REINFORCEMENT	
004	813085-705X	5	LEJEHUS LAGERGEHÄUSE	BEARING HOUSING	
005	813085-730X	1	VINKELGEAR WINKELGETRIEBE	ANGULAR GEAR	
006	811315-9697	8	SKRUE M12X40 SCHRAUBE	SCREW	
007	811220-4127	8	STÅLMØTRIK M12 STAHLMUTTER M12	STEEL NUT M12	
008	811219-0210	48	SKRUE M10-30 12.9 DELTA B SCHRAUBE M10-30 12.9 DELTA B	SCREW M10-30 12.9 DELTA B	
009	811219-0208	11	KNIVBJÆLKE SKRUE SCHNITTBALKEN SCHRAUBE	SCREW FOR CUTTERBAR	
010	812085-729X	77	MØTRIK M10 H=10 MUTTER M10 H=10	NUT M10 H=10	
011	811219-0227	5	UNBRACOSKRUE M10-20 MK INNENSECHSKANTSCHR M10-20 MK	ALLEN SCREW M10-20 MK	
012	812085-732X	4	SKRUE UH M10X30 SCHRAUBE UH M10X30	SCREW UH M10X30	
013	812085-717X	11	TAP ZAPFEN	DOWEL	
014	812085-719X	11	SKIVE 40,3X51,3X3 SCHEIBE 40,3X51,3X3	WASHER 40,3X51,3X3	
015	812085-720X	11	LEJE 6208 N/C3 LAGER 6208 N/C3	BEARING 6208 N/C3	
016	812085-721X	11	SPRINGRING KLEMMRING	SPRINGRING	
017	812085-722X	5	MELLEMHJUL Z36 M3 ZWISCHENRAD Z36 M3	INTERMEDIATE WHEEL M36 M3	
018	812085-724X	6	MELLEMHJUL Z45 M3 ZWISCHENRAD Z45 M3	INTERMEDIATE WHEEL Z45 M3	
019	812085-718X	11	SKRUE M20X18 SCHRAUBE M20X18	SCREW M20X18	
020	812085-723X	11	MØTRIK MUTTER	NUT	
021	812085-733X	9	KNIVBJÆLKE SKRUE SCHNITTBALKEN SCHRAUBE	SCREW FOR CUTTERBAR	
022	812085-735X	2	SPÆNDSTIFT M10X12 D1481 SPANNSTIFT M10X12 D1481	ROLL PIN M10X12 D1481	
023	812085-734X	4	SKRUE CH M8X25 SCRAUBE M8X25	SCREW CH M8X25	

Fig. 4

Fig. 30

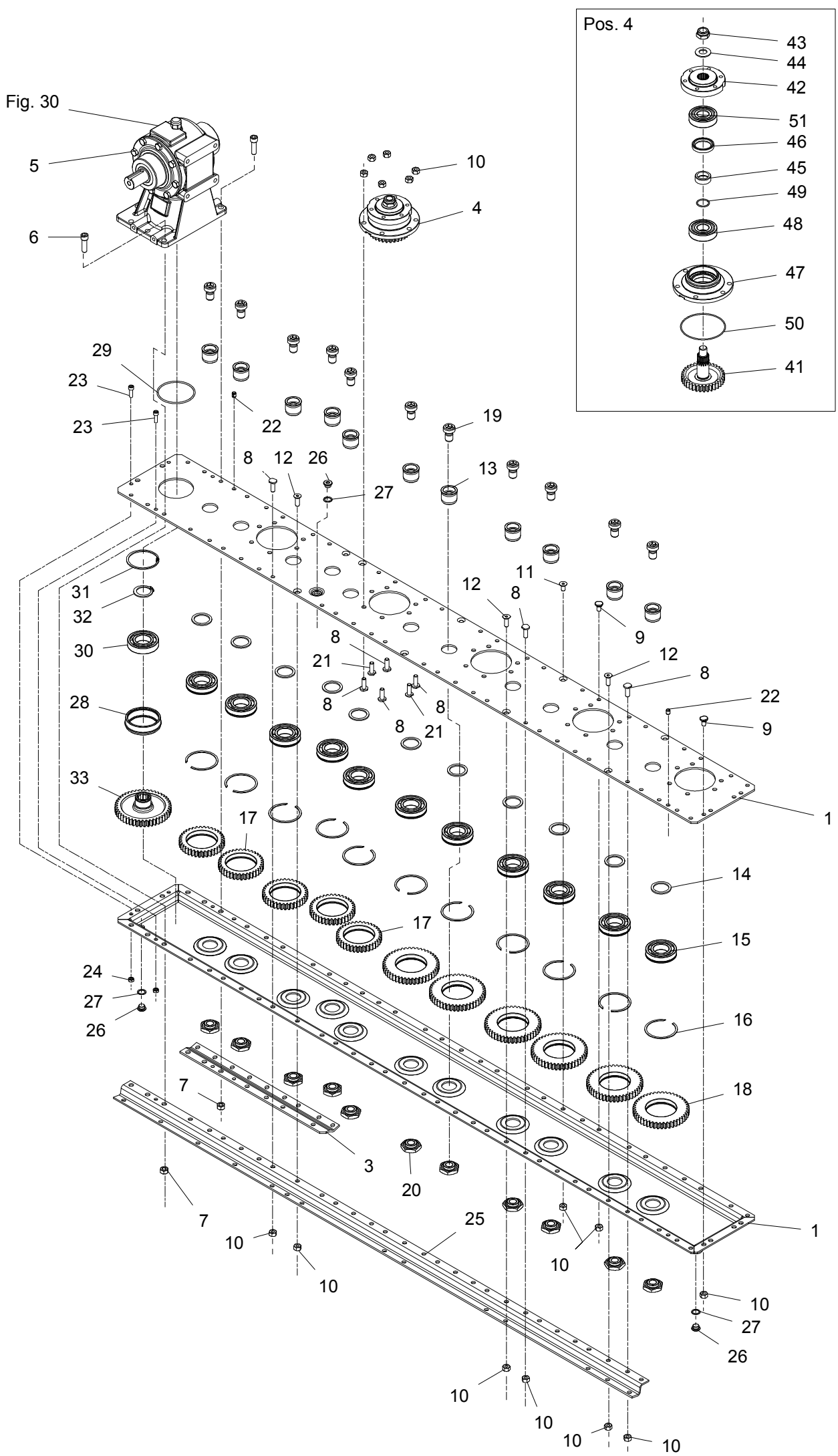

SB-0016/2		SB 2005	Figure No 004	>=B029040171108	Hertil, Dazu To this, A ceci
Position No	Spare Part No	Qty	Beskrivelse	Designation	Acc Part No Qty
024	811220-2122	4	STÅLMØTRIK M8 STAHLMÜTTER M8	STEEL NUT M8	
025	812085-744X	1	FORSTÆRKNING VERSTÄRKERUNG	REINFORCEMENT	
026	812085-731X	3	PROP 3/8 VERSCHLUSS 3/8	PLUG 3/8	
027	811315-9671	3	SKIVE 17 X 22 X 1,5 SCHEIBE 17 X 22 X 1,5	WASHER 17 X 22 X 1,5	
028	812085-725X	1	BØSNING BUCHSE	BUSH	
029	812085-726X	1	O-RING O-RING	O-RING	
030	812085-727X	1	LEJE 6208 C3 LAGER 6208 C3	BEARING 6208 C3	
031	811255-7102	1	LÅSERING 80 MM INDVENDIG SICHERUNGSRING 80 MM INNEN	SNAP RING 80 MM INNER	
032	811255-4204	1	LÅSERING 40-2,5 SICHERUNGSRING 40-2,5	SNAP RING 40-2,5	
033	812085-728X	1	TANDHJUL Z45 M3 ZAHNRAD Z45 M3	SPROCKET WHEEL Z45 M3	
041	812085-706X	1	TANDHJUL Z34 M20 ZAHNRAD Z34 M20	SPROCKET WHEEL Z34 M20	
042	812085-707X	1	FLANGE FLANSCH	FLANGE	
043	812085-709X	1	LÅSEMØTRIK M20X1,5 GEGENMÜTTER M20X1,5	LOCK NUT M20X1,5	
044	811434-0108	1	TALLERKENFJEDER 20,0-40-2,5 TELLERFEDER 20,0-40-2,5	DISC SPRING 20,0-40-2,5	
045	812085-710X	1	BØSNING BUCHSE	BUSH	
046	812085-711X	1	OLIETÆTNINGSRING DICHTUNGSRING ÖL	SEAL RING OIL	
047	812085-708X	1	LEJEHUS LAGERGEHÄUSE	BEARING HOUSING	
048	812085-712X	1	LEJE 6306C3/Z2 LAGER 6306C3/Z2	BEARING 6306C3/Z2	
049	812085-714X	1	O-RING 3112 O-RING 3112	O-RING 3112	
050	812085-715X	1	O-RING O-RING	O-RING	
051	812085-716X	1	KUGLELEJE 6306 C3 2RS KUGELLAGER 6306 C3 2RS	BALL BEARING 6306 C3 2RS	

Fig. 5

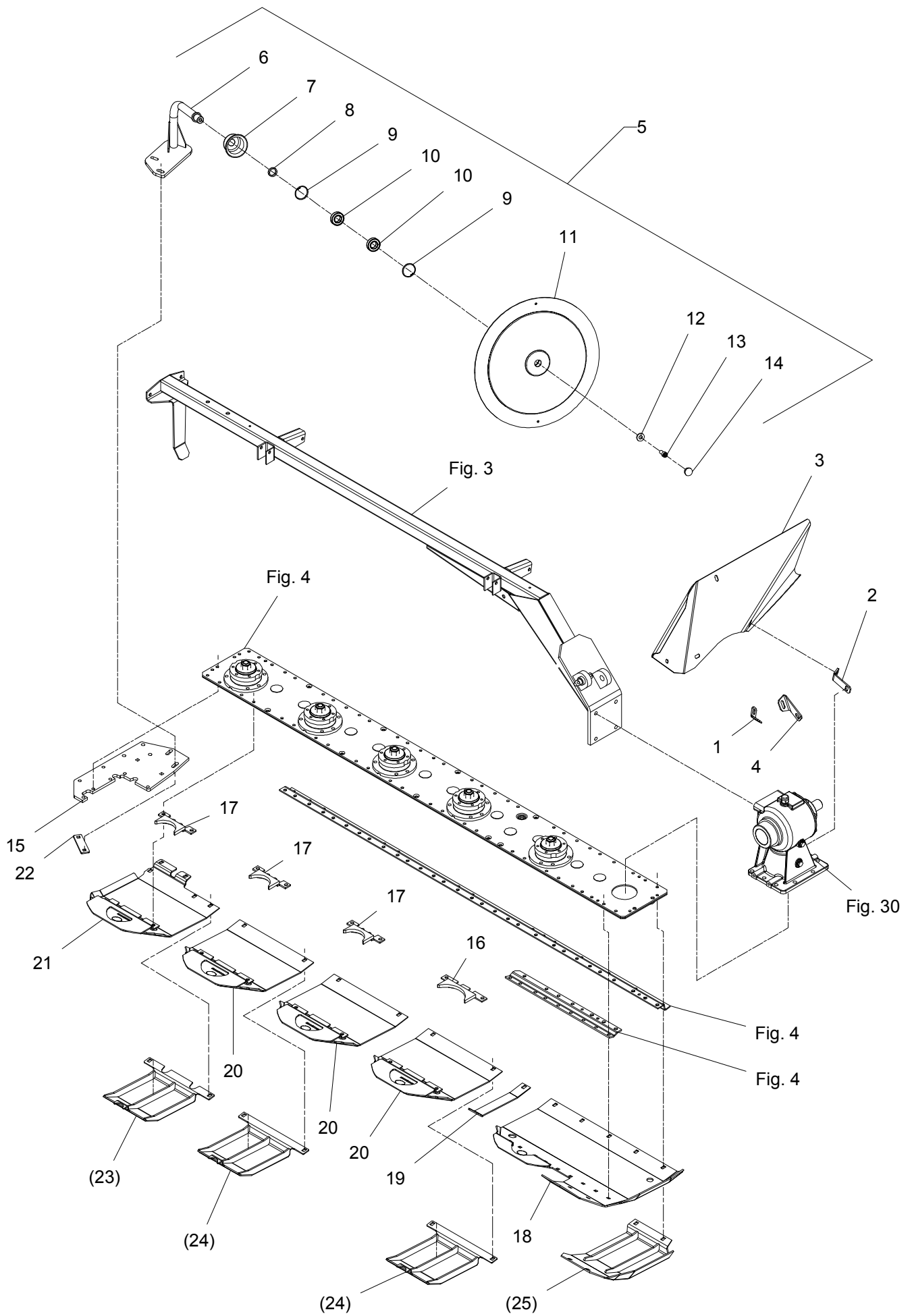

SB-0016/2		SB 2005		Figure No 005		>=B029040171108		Hertil, Dazu	
Position No Spare Part No		Qty	Beskrivelse	Designation		To this, A ceci		Acc Part No	Qty
001	812082-493X	1	BESLAG BESCHLAG	FITTINGS					
002	812082-491X	1	BESLAG BESCHLAG	FITTINGS					
003	812082-490X	1	SKÆRM, INDRE ABSCHIRMUNG, INNERE	GUARD, INNER		811215-3228	4		
						811220-3321	4		
						811241-2308	4		
004	812082-492X	1	BESLAG BESCHLAG	FITTINGS					
005	813082-161X	1	SKÅRRULLE SML. SCHWADROLLER KPL.	SWATH ROLLER ASS.					
006	813082-162X	1	SKÅRRULLE ARM ARM FÜR SCHWADROLLE	ARM FOR SWATHROLLER					
007	812279-221X	1	DÆKSEL DECKEL	COVER					
008	812279-223X	1	AFSTANDSRING Distanzring	DISTANCE RING					
009	811255-4102	2	LÅSERING 47 MM INDVENDIG SICHERUNGSRING 47 MM INNEN	SNAP RING 47 MM INNER					
010	811331-2303	2	KUGLELEJE 6005 2RS KUGELLAGER 6005 2RS	BALL BEARING 6005 2RS					
011	813082-410X	1	SKÅRRULLE SCHWADROLLE	SWATH ROLLER					
012	812279-023X	1	SKIVE SCHEIBE	WASHER					
013	811219-0220	1	UNBRACOSKRUE M12-25 MC INNENSECHSKANTSCHR. M12-25 MC	ALLEN SCREW M12-25 MC					
014	811165-0189	1	AFDÆKNINGSPROP ABDECKUNGSVERSCHLUSS	COVERING PLUG					
015	812088-561X	1	ANKERPLADE ANKERPLATTE	ANCHOR PLATE					
016	813088-551X	1	MODSKÆR GEGENSCHNEIDE	SHEAR BAR					
017	813088-554X	3	MODSKÆR GEGENSCHNEIDE	SHEAR BAR		811220-3321	6		
018	813088-546X	1	SLÆBESKO GLEITKUFE	GUIDE SHOE		811215-3222	14		
						811220-3321	14		
019	812088-560X	1	SLÆBESKO GLEITKUFE	GUIDE SHOE		811215-3222	1		
						811220-3321	1		
020	813088-549X	3	SLÆBESKO GLEITKUFE	GUIDE SHOE		811215-3222	2		
						811219-0210	2		
						811220-3321	2		
						811220-3323	2		
021	813088-557X	1	SLÆBESKO GLEITKUFE	GUIDE SHOE		811215-3222	2		
						811215-3320	2		
						811219-0210	2		
						811220-3321	4		
						811220-3323	2		

Fig. 5

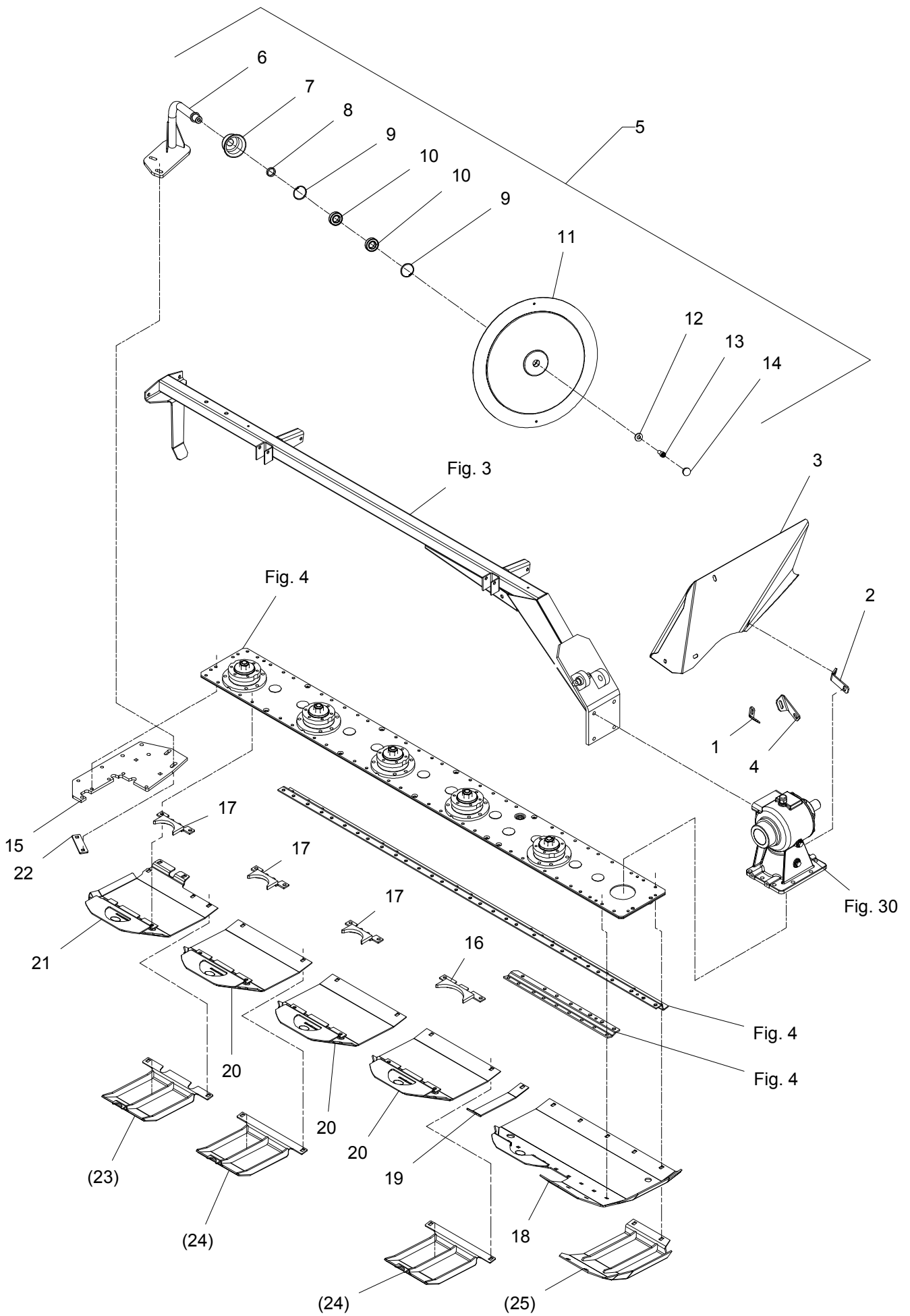

SB-0016/2		SB 2005		Figure No 005		>=B029040171108		Hertil, Dazu	
Position No Spare Part No		Qty	Beskrivelse	Designation		Acc Part No		Qty	
022	812082-164X	1	SPENDEPLADE SPANNPLATTE	RETAINING PLATE					
023	813082-165X	T 1	SLÆBESKO, HØJ GLEITKUFE, HOCH	GUIDE SHOE, HIGH		811215-3226		2	
						811220-3321		2	
024	813088-584X	T 2	SLÆBESKO, HØJ GLEITKUFE, HOCH	GUIDE SHOE, HIGH		811215-3226		2	
						811220-3321		2	
025	813088-585X	T 1	SLÆBESKO, HØJ GLEITKUFE, HOCH	GUIDE SHOE, HIGH		811215-3226		4	
						811220-3321		4	

Fig. 6

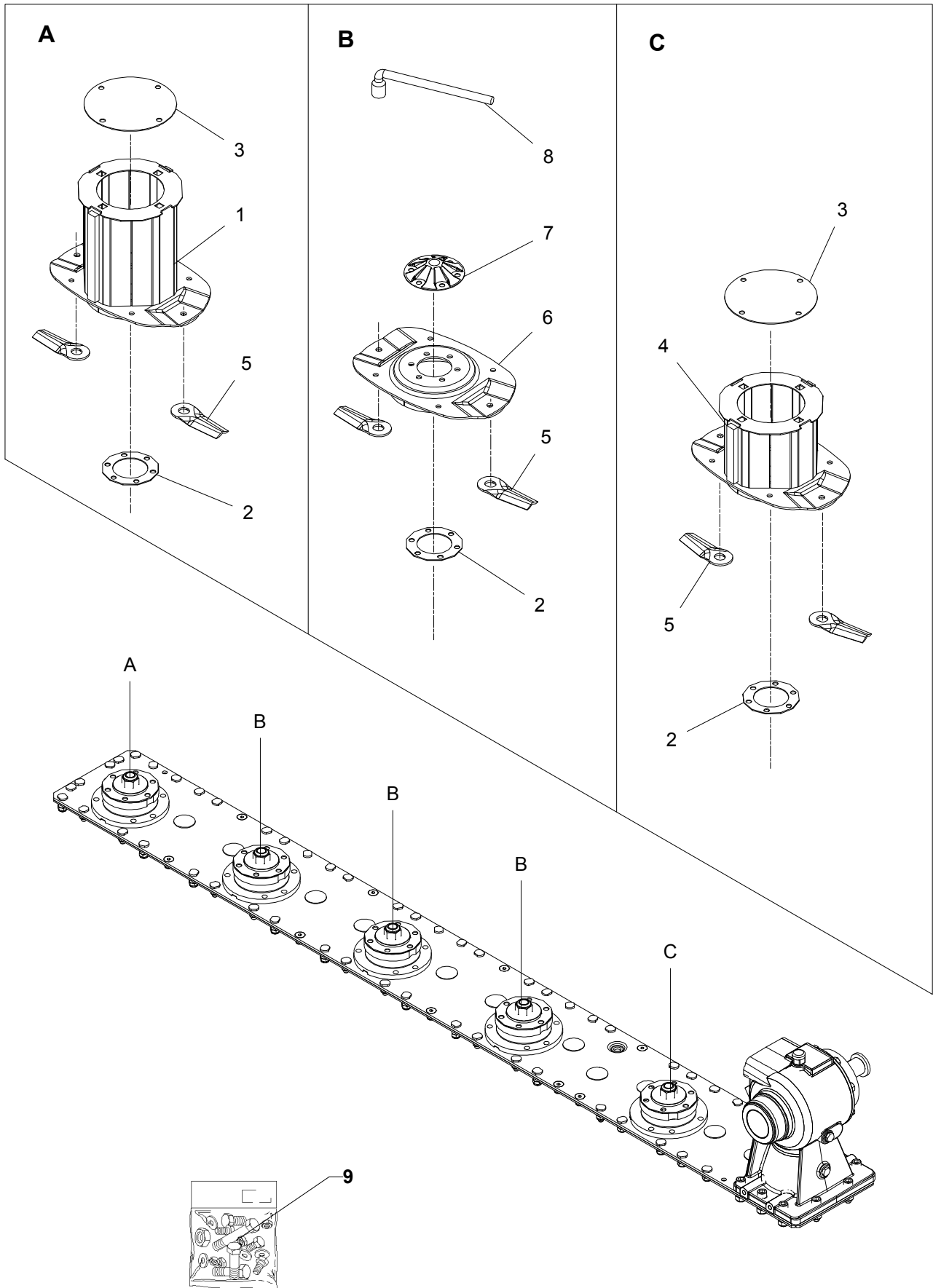

SB-0016/2	SB 2005	Figure No	006	>=B029040171108	Hertil, Dazu	To this, A ceci
Position No	Spare Part No	Qty	Beskrivelse	Designation	Acc Part No	Qty
001	813088-588X	1	HDS-SKIVE M. TROMLE HDS-SCHEIBE M. WALZE	HDS-DISC W. BARREL	811213-3224 811219-0809 811220-4323 811241-2402	6 2 2 2
002	812085-704X	5	MELLEMLÆG DICHTUNG	DISTANCE PIECE		
003	812089-180X	2	TÆTNING DICHTUNG	SEAL	811213-3222 811220-3922	4 4
004	813214-725X	1	HDS-SKIVE M. TROMLE HDS-SCHEIBE M. WALZE	HDS-DISC W. BARREL	811213-3224 811219-0809 811220-4323 811241-2402	6 2 2 2
005	811380-0013	10	KNIV MAEHKLINGE	KNIFE		
006	813214-724X	3	SKIVE SCHEIBE	DISC	811213-3224 811219-0809 811220-4323 811241-2402	6 2 2 6
007	812085-703X	3	TOP OBERTEIL	TOP		
008	811343-0405	1	VINKELNØGLE WINKELSCHLUESSEL	DIAGONAL WRENCH		
009	813082-312X	1	VÆRKTØJSPAKKE HD-SKIVER WERKSEUGSPACKET HD-SCHEIBEN	TOOL KIT HD-DISCS		

Fig. 30

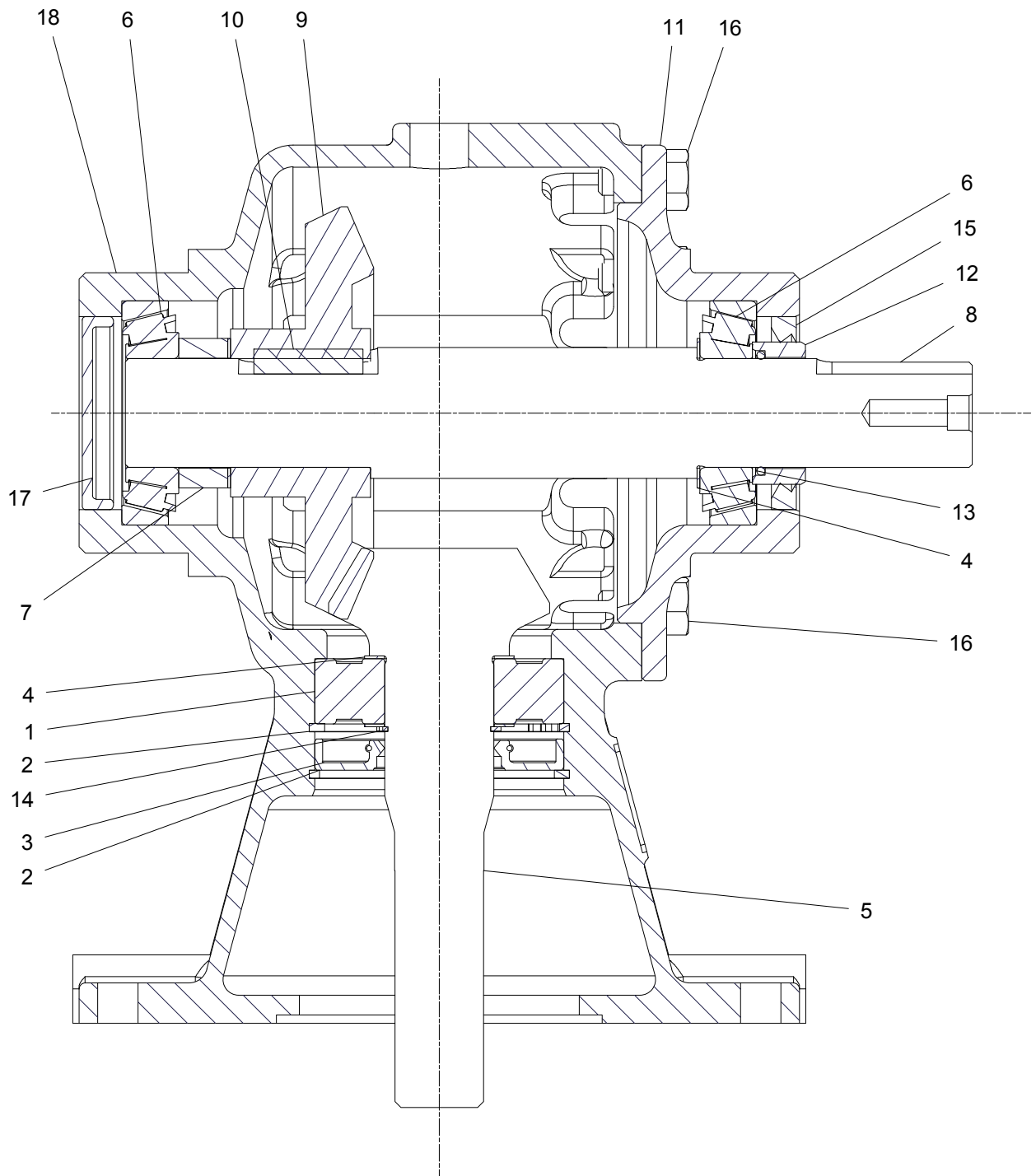

SB-0016/2		SB 2005	Figure No 030	>=B029040171108	Hertil, Dazu To this, A ceci
Position No	Spare Part No	Qty	Beskrivelse	Designation	Acc Part No Qty
000	813085-730X	1	VINKELGEAR WINKELGETRIEBE	ANGULAR GEAR	
001	811331-4102	1	KUGLELEJE 6307 KUGELLAGER 6307	BALL BEARING 6307	
002	811255-7102	2	LÅSERING 80 MM INDVENDIG SICHERUNGSRING 80 MM INNEN	SNAP RING 80 MM INNER	
003	811315-9271	1	OLIETÆTNINGSRING OELDICHTUNGSRING	OIL TIGHTENING RING	
004	811315-9140	4	SKIVESET DISTANZSCHEIBENSATZ	SET OF SHIMS	
005	811315-9693	1	SPIDSHJUL Z16 M4 KEGELRAD Z16 M4	BEVEL PINION WHEEL Z16 M4	
006	811331-9909	2	RULLELEJE ROLLENLAGER	ROLLER BEARING	
007	811315-9694	1	AFSTANDSRING DISTANZ RING	DISTANCE RING	
008	811315-9695	1	AKSEL WELLE	SHAFT	
009	811315-9264	1	TANDHJUL ZAHNRAD	SPROCKET WHEEL	
010	811315-9274	1	PASFEDER FEDERKEIL	FLAT KEY	
011	811315-9266	1	DEKSEL DECKEL	COVER	
012	811315-9268	1	BØSNING BUECHSE	BUSH	
013	811315-9267	1	O-RING 34-59 O-RING 34-59	O-RING 34-59	
014	811255-3202	1	LÅSERING 35 MM UDVENDIG SICHERUNGSRING 35 MM AUSSEN	SNAP RING 35 MM OUTER	
015	811315-9720	1	TÆTNINGSRING DICHTUNGSRING	SEAL RING	
016	811315-9265	8	BOLT BOLZEN	BOLT	
017	811315-9298	1	DEKSEL DECKEL	COVER	
018	811315-9698	1	GEARHUS GETRIEBEKASTEN	GEARBOX	
019	811315-9118	2	PROP VERSCHLUSS	PLUG	
020	811315-9116	1	UDLUFTNINGSPROP ENTLLUFTUNGSSCHRAUBE	AIR ESCAPE PLUG	

Fig. 40

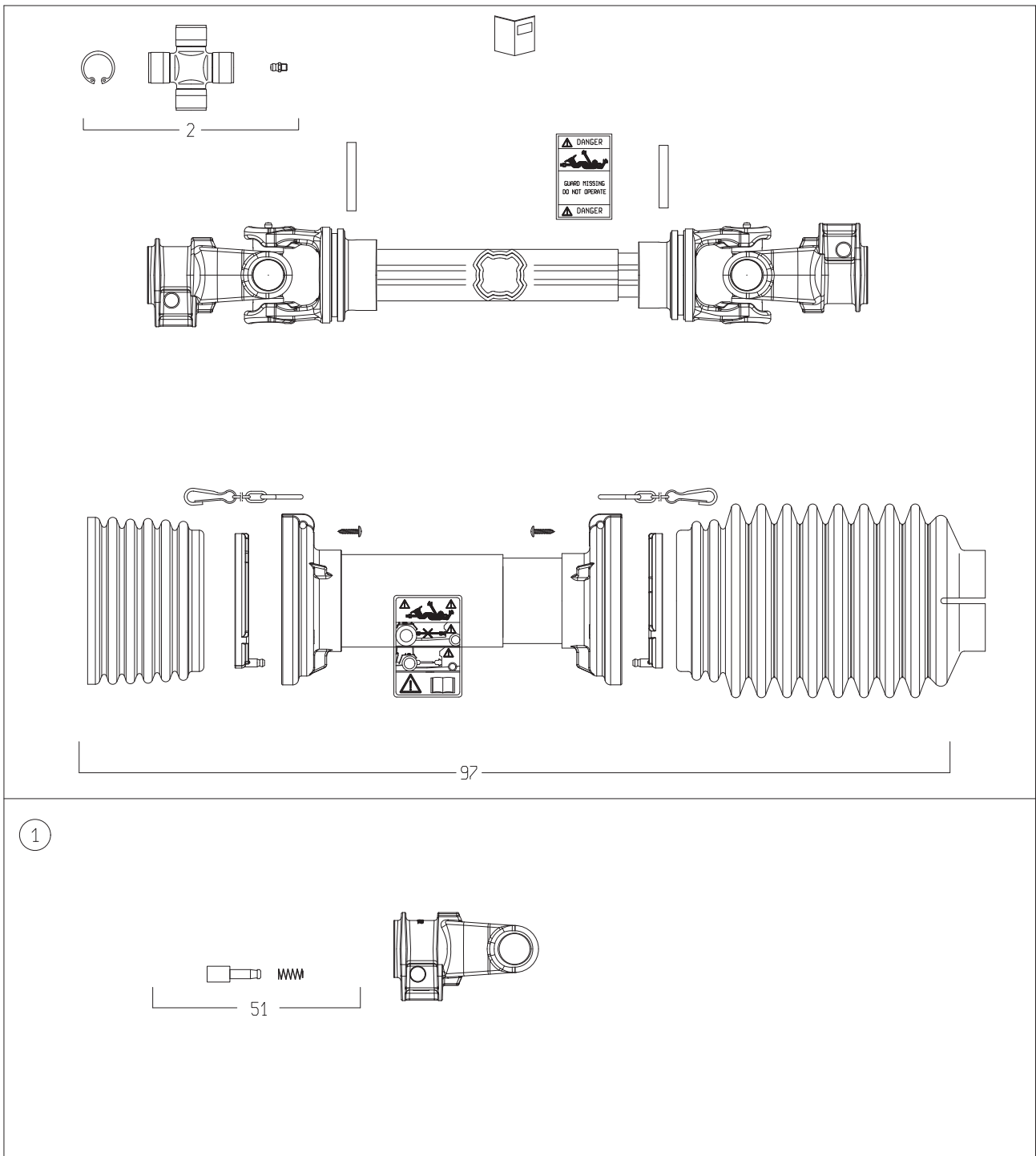

SB-0016/2		SB 2005		Figure No	040	>=B029040171108	Hertil, Dazu	
Position No		Spare Part No	Qty	Beskrivelse	Designation	To this, A ceci		Acc Part No Qty
000	811350-0061	1	KRAFTOVERFØRINGSAKSEL GELENKWELLE	PTO SHAFT				
002	811350-2102	2	KRYDS KREUTZ	CENTRE CROSS				
051	811350-9001	2	LÅSESTIFT KOMPLET SCHIEBSTIFT KOMPLETT	LOCK PIN COMPLETE				
097	811350-2115	1	BESKYTTELSESRØR SCHUTZROHR	PROTECTION TUBE				

Fig. 41

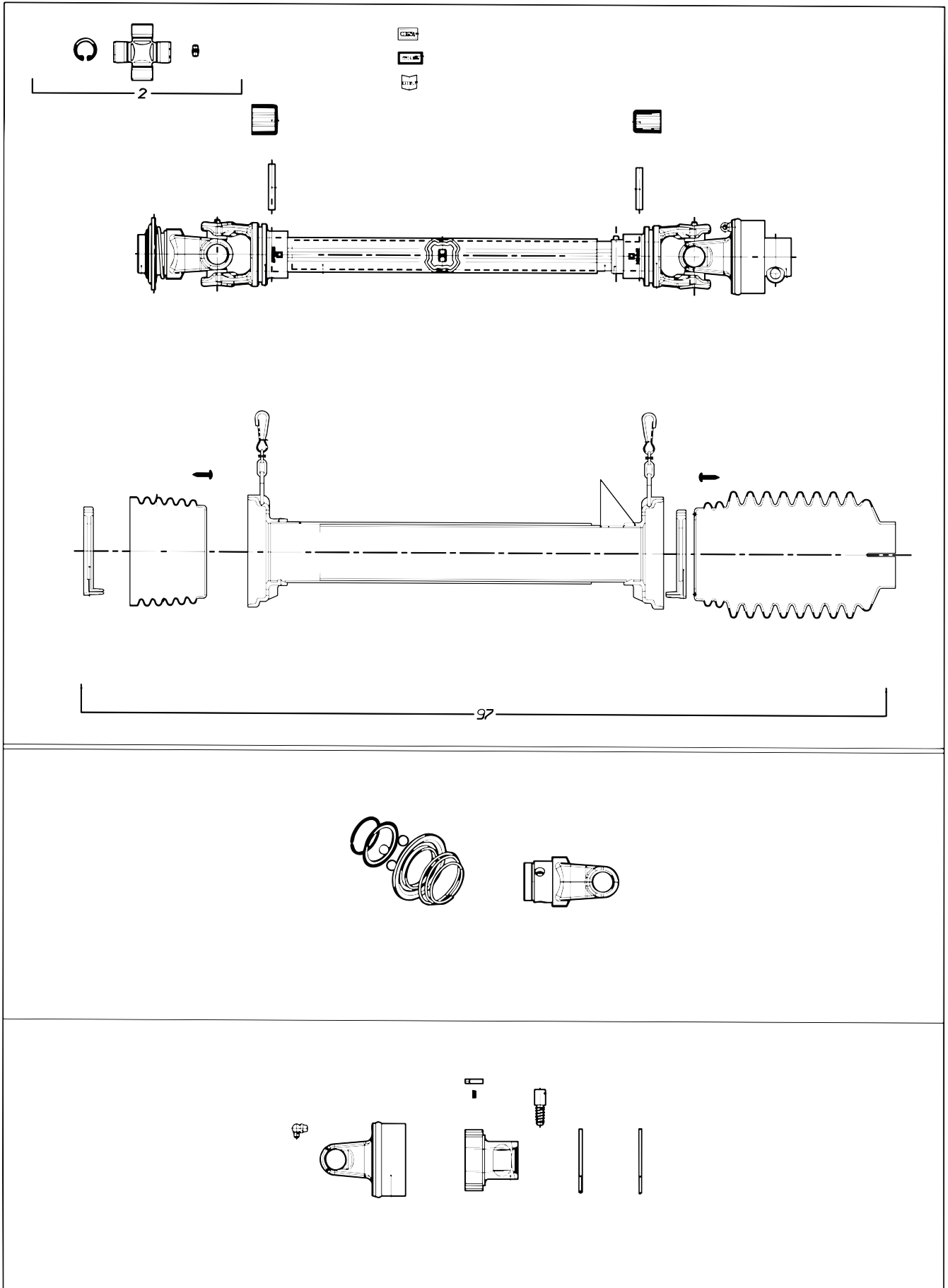

SB-0016/2		SB 2005		Figure No 041		>=B029040171108		Hertil, Dazu	
Position No		Spare Part No		Qty	Beskrivelse	Designation		To this, A ceci	
								Acc	Part No Qty
000	811350-0054	1	KRAFTOVERFØRINGSAKSEL GELENKWELLE		PTO SHAFT				
002	811350-2102	2	KRYDS KREUTZ		CENTRE CROSS				
097	811350-2103	1	BESKYTTELSESRØR, KOMPLET SCHUTZROR, KOMPLETT		SHIELD, COMPLETE				

Fig. 80

Tilbehør - Zubehör - Accessories

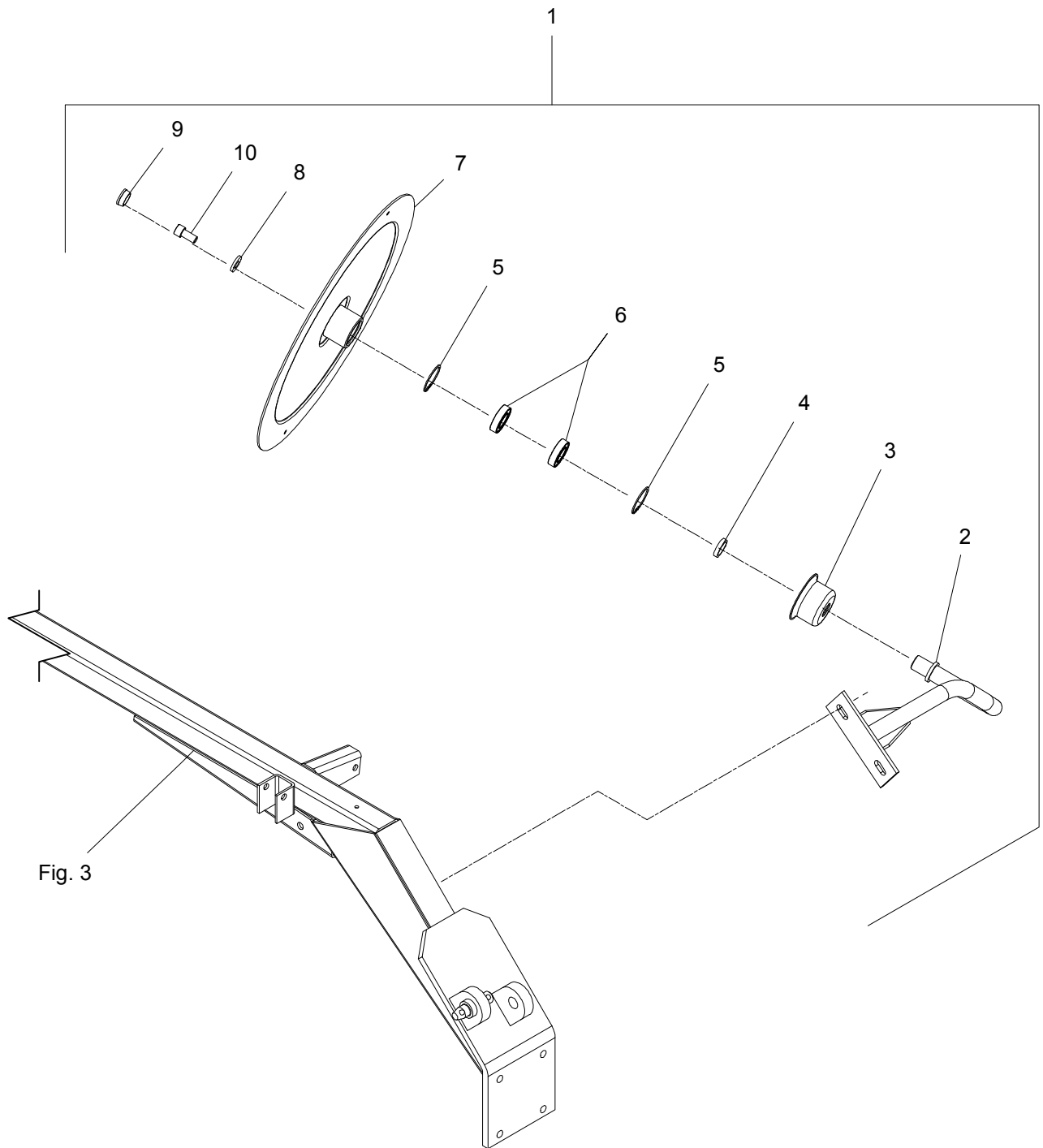

SB-0016/2		SB 2005		Figure No	080	>=B029040171108	Hertil, Dazu To this, A ceci		
Position No	Spare Part No	Qty	Beskrivelse	Designation		Acc	Part No	Qty	
001	814080-8025	1	SKÅRRULLE, VENSTRE SCHWADPLATTE, LINKS	SWATH ROLLER, LEFT					
002	813082-431X	1	ARM ARM	ARM		811213-4224		2	
						811241-3702		2	
003	812279-221X	1	DEKSEL DECKEL	COVER					
004	812279-223X	1	AFSTANDSRING Distanzring	DISTANCE RING					
005	811255-4102	2	LÅSERING 47 MM INDVENDIG SICHERUNGSRING 47 MM INNEN	SNAP RING 47 MM INNER					
006	811331-2303	2	KUGLELEJE 6005 2RS KUGELLAGER 6005 2RS	BALL BEARING 6005 2RS					
007	813082-410X	1	SKÅRRULLE SCHWADROLLE	SWATH ROLLER					
008	812279-023X	1	SKIVE SCHEIBE	WASHER					
009	811165-0189	1	AFDÆKNINGSPROP ABDECKUNGSVERSCHLUSS	COVERING PLUG					
010	811219-0220	1	UNBRACOSKRUE M12-25 MC INNENSECHSKANTSCHR. M12-25 MC	ALLEN SCREW M12-25 MC					



Kongskilde Agriculture

www.kongskilde.com

 **KONGSKILDE**
Moving agriculture ahead