

# GMS 320



Reservedelsliste  
Spare parts list  
Ersatzteilliste  
Liste de pièce de rechange

A2



Always state the serial number and if possible the year of the machine when ordering spare parts whereby you save time and money and facilitates matters for us.  
Please enter the number of your machine here:

No..... Delivered on the ..... / ..... 20.....

Appropriate when ordering parts.  
The serial number is located as shown on the figure.

Bei Ersatzteilbestellungen ist die Fabrikationsnummer Ihrer Maschine unbedingt anzugeben. Das erspart Ihnen Zeit, Geld und Ärger und erleichtert uns die Abfertigung.  
Tragen Sie die Nummer Ihrer Maschine bitte hier ein:

Nr..... Geliefert am ..... / ..... 20.....

dann haben Sie bei Ersatzteilbestellungen immer die Nummer bei der Hand.  
Die Fabrikationsnummer ist im Rahmen eingeschlagen, siehe Figur.

Lorsque vous commandez des pièces détachées, indiquez toujours le numéro de série de votre machine et si possible son année de fabrication. Vous éviterez des pertes de temps et vous nous faciliterez le travail.

Prière de noter ici le numéro de série de votre machine:

Numéro..... Livrée le ..... / ..... 20.....

Ceci vous sera utile lorsque vous commanderez des pièces.  
Le numéro de série est gravé dans le cadre comme indiqué sur la figure.

Bestiller De reservedele så opgiv venligst maskinens fabrikationsnummer og eventuelt købsår. Det sparer Dem tid, penge og ærgrelser og os unødigt besvær.  
De kan notere nummeret på Deres maskine her:

Nr..... Leveret den ..... / ..... 20.....

så har De det ved hånden, når De eventuelt skal bestille reservedele.  
Fabrikationsnummeret findes indhugget i rammen, som vist på figuren.

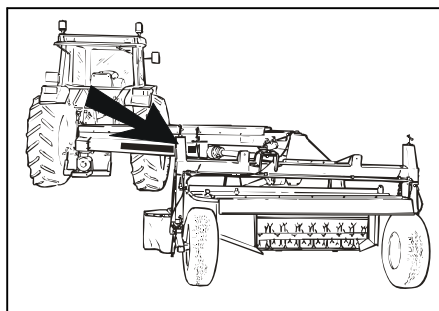

# SPARE PARTS BOOK ERSATZTEILKATALOG CATALOGUE DE PIÈCES RESERVEDELSKATALOG

The book is divided into 5 passages:

1. Description of the spare part book.
2. Number key for assembly parts.
3. Number key showing on which figures the spare part numbers can be found.
4. Figure key showing on which figures the parts can be found.
5. Spare parts list.

Der Katalog ist in 5 Abschnitte eingeteilt:

1. Beschreibung des Ersatzteilkataloges.
2. Nummernschlüssel für Montagezubehör.
3. Nummernschlüssel mit Angabe der jeweiligen Ersatzteilnummer.
4. Figurliste mit Angabe, auf welche Figuren die Teile zu finden sind.
5. Ersatzteilliste.

Le catalogue est divisé en 5 sections:

1. Description du catalogue de pièces.
2. Liste de pièces de montage.
3. Numéros des pièces de rechange indiquant le numéro de figure.
4. Liste des figures indiquant sur quelle figure se trouvent les pièces.
5. Liste de pièces de rechange.

Kataloget er opdelt i 5 afsnit:

1. Beskrivelse af reservedelskataloget.
2. Nummernøgle for monteringsdele.
3. Nummernøgle - viser på hvilke figurer reservedelsnumrene findes.
4. Figurnøgle - viser på hvilke figurer delene findes.
5. Reservedelsliste.

**Description of the spare parts book:**  
**Beschreibung des Ersatzteilkataloges:**  
**Discription du catalogue de pièces:**  
**Beskrivelse af reservedelskataloget:**

**The spare parts book is built up as follows:**

Fig. 01-29 Standard	Fig. 50-59 Hub
Fig. 30-39 Gear	Fig. 60-79 Variation of standard (Accessory)
Fig. 40-49 PTO drives	Fig. 80- Accessory

**Der Ersatzkatalog ist so aufgebaut:**

Fig. 01-29 Standard	Fig. 50-59 Nabe
Fig. 30-39 Getriebe	Fig. 60-79 Variation vom Standard (Zubehör)
Fig. 40-49 Gelenkwellen	Fig. 80- Zubehör

**Le catalogue de pièces est arrangé comme suit:**

Fig. 01-29 Standard	Fig. 50-59 Moyeu
Fig. 30-39 Boîtier	Fig. 60-79 Variation du standard (Accessoire)
Fig. 40-49 Arbres à cardan	Fig. 80- Accessoire

**Reservedelskataloget er opbygget således:**

Fig. 01-29 Standard	Fig. 50-59 Nav
Fig. 30-39 Gear	Fig. 60-79 Variation af standard (Tilbehør)
Fig. 40-49 Kraftoverføringsaksler	Fig. 80- Tilbehør

**Position No.:**  
The position No. marked "(j)" is not standard. Is delivered as accessory.  
**Positionsnummer:**  
Die Positionsnummer, die mit "(j)" gezeichnet ist, ist nicht der Standard. Wird als Zubehör geliefert.  
**No de pos.:**  
Le numéro de position marqué d'un "(j)" n'est pas une pièce standard. Livrée comme accessoire.  
**Pos. nr.:**  
Positionsnummer mærket med "(j)" er ikke standard. Leveres som tilbehør

POS.	VARENUMMER	ANTAL	BENEVNELSE	BEZEICHNUNG	DESIGNATION	HERTIL, DAZU TO THIS, À CECI
33.	1340-9153 T	2	KRYDS KREUTZGARNITUR >=0003219 <=0003448	CENTRE	CENTRE	1341-9187 1
33.1	1350-7005	2	KRYDS KREUTZGARNITUR >=0003219	CENTRE	CENTRE	1350-9052 4 1350-9104 1
34.	1340-0196	1	PROFILAKSEL PROFILGABEL >=0003219 <=0003448	PROFIL FORK	PROFIL FORK	
34.1	1350-8008	1	PROFILAKSEL PROFILGABEL >=0003219	PROFIL FORK	PROFIL FORK	

**Article no.:**  
The article no. marked "T" is not standard. Is delivered as accessories. the article no. marked "+": Modification is being made.  
**Warennummer:**  
Ist eine Warennummer mit "T" gekennzeichnet, wird sie als Zubehör geliefert. Eine Warennummer mit "+" ist als Modifikation unterwegs.  
**No. D'article:**  
Le no d'article marqué d'un "T" n'est pas un article standard. Livré comme accessoire. No. d'article marqué de "+": Une modification viendra.  
**Varenr.:**  
Varennummer mærket med "T" er ikke standard. Leveres som tilbehør. Varennummer mærket med "+": ændring undervejs.

**Designation:**  
>=0003219 <=0003448  
Spare part used for machine from serial No. 3219 up to No. 3448 both Nos. included.  
**Benennung:**  
>=0003219 <=0003448  
Ersatzteil für Maschinen von Fabrikationsnummer 3219 bis Nr. 3448.  
**Désignation:**  
>=0003219 <=0003448  
Pièce de rechange employée sur machines à partir de no de série 3219 jusq'à et y compris no 3448.  
**Benævnelse:**  
>=0003219 <=0003448  
Reservedel anvendt på maskine fra og med fabrikationsnummer 3219 til og med nr. 3448

**Quantity:**  
States quantity of parts for machine. In connection with subassemblies: Quantity for the assembly.  
**Anzahl:**  
Anzahl Teile je Maschine. Bei Untersammlungen: Anzahl je Sammlung.  
**Quantité:**  
Quantité de pièces par machine. Pour les sous-assemblages: pièces par assemblage.  
**Antal:**  
Antal dele pr. maskine. Ved undersamlinger: dele pr. samling.

**To this:**  
States which and how many mounting assemblies (screws, nuts, discs etc.) are used with the spare part. See under number key for assembly parts  
**Dazu:**  
Angabe von Montageteilen (Schrauben, Muttern, Scheiben usw.) die zusammen mit dem Ersatzteil angewendet werden sollen. Siehe Nummernschlüssel für Montagezubehör.  
**Pour ceci:**  
Indique lesquelles et combien de pièces de montage (vis, écrous, rondelles etc.) sont employées avec la pièce de rechange. Voir dans la liste de numéros pour pièces de montage.  
**Hertil:**  
Angiver hvilke og hvor mange monteringsdele (skruer, møtrikker, skiver osv.) der anvendes sammen med reservedelen. Se under nummernøgle for monteringsdele.

GMS-0020/2		NUMMERNØGLE FOR MONTERINGSDELE - NUMMERSLÅSSEL FØR MONTAGEZUBEHØR	
		NUMBER KEY FOR ASSEMBLY PARTS - LISTE DE PIÈCES DE MONTAGE	
VARENUMMER	BENØVNELSE	BEZEICHNUNG	DESIGNATION
1213-2126	STÅLSETS KRUE M8-15	ST. SETSCHRAUBE M8-15	STEEL SET SCREW M8-15
1213-2224	STÅLSETS KRUE M8-25	ST. SETSCHRAUBE M8-25	STEEL SET SCREW M8-25
1213-3222	STÅLSETS KRUE M10-20	ST. SETSCHRAUBE M10-20	STEEL SET SCREW M10-20
1213-3224	STÅLSETS KRUE M10-25	ST. SETSCHRAUBE M10-25	STEEL SET SCREW M10-25
1213-3322	STÅLSETS KRUE M10-30	ST. SETSCHRAUBE M10-30	STEEL SET SCREW M10-30
1213-3324	STÅLSETS KRUE M10-35	ST. SETSCHRAUBE M10-35	STEEL SET SCREW M10-35
1213-4322	STÅLSETS KRUE M12-30	ST. SETSCHRAUBE M12-30	STEEL SET SCREW M12-30
1213-4327	STÅLSETS KRUE M12-35 KVAL 10.9	ST. SETSCHRAUBE M12-35 Q 10.9	STEEL SET SCREW M12-35 Q 10.9
1213-5224	STÅLSETS KRUE M16-25	ST. SETSCHRAUBE M16-25	STEEL SET SCREW M16-25
1213-5322	STÅLSETS KRUE M16-30	ST. SETSCHRAUBE M16-30	STEEL SET SCREW M16-30
1213-5420	STÅLSETS KRUE M16-40 KVAL 10.9	ST. SETSCHRAUBE M16-40 Q 10.9	STEEL SET SCREW M16-40 Q 10.9
1213-5422	STÅLSETS KRUE M16-40	ST. SETSCHRAUBE M16-40	STEEL SET SCREW M16-40
1214-3224	STÅLSKRUE M10-55	STAHLSECHSKANTSCHRAUBE M10-55	STEEL SCREW M10-55
1214-3226	STÅLSKRUE M10-60	STAHLSECHSKANTSCHRAUBE M10-60	STEEL SCREW M10-60
1214-3424	STÅLSKRUE M10-110	STAHLSECHSKANTSCHR. M10-110	STEEL SCREW M10-110
1214-4126	STÅLSKRUE M12-45	STAHLSECHSKANTSCHRAUBE M12-45	STEEL SCREW M12-45
1214-4228	STÅLSKRUE M12-65 KV. 10.9	STAHLSECHSKANTSCHR. M12-65 Q 10.9	STEEL SCREW M12-65 Q 10.9
1214-4326	STÅLSKRUE M12-80	STAHLSECHSKANTSCHRAUBE M12-80	STEEL SCREW M12-80
1214-4424	STÅLSKRUE M12-110	STAHLSECHSKANTSCHRAUBE M12-110	STEEL SCREW M12-110
1214-5430	STÅLSKRUE M16-130	STAHLSECHSKANTSCHR. M16-30	STEEL SCREW M16-130
1214-6226	STÅLSKRUE M20-65	STAHLSECHSKANTSCHRAUBE M20-65	STEEL SCREW M20-65
1214-6322	STÅLSKRUE M20-70	STAHLSECHSKANTSCHRAUBE M20-70	STEEL SCREW M20-70
1215-2124	BREDES KRUE M8-15	FLACHRUNDSCHRAUBE M8-15	CARRIAGE SCREW M8-15
1215-2222	BREDES KRUE M8-20	FLACHRUNDSCHRAUBE M8-20	CARRIAGE SCREW M8-20
1215-3222	BREDES KRUE M10-20 H-3	FLACHRUNDSCHRAUBE M10-20 H-3	CARRIAGE SCREW M10-20 H-3
1215-3226	BREDES KRUE M10-25 KVAL 8,8	FLACHRUNDSCHRAUBE M10-25 Q 8,8	CARRIAGE SCREW M10-25 Q 8,8
1215-3228	BREDES KRUE M10-20 KV 8,8	FLACHRUNDSCHRAUBE M10-20 Q 8,8	CARRIAGE SCREW M10-20 Q 8,8
1215-5522	BREDES KRUE M16-50	FLACHRUNDSCHRAUBE M16-50	CARRIAGE SCREW M16-50
1219-0210	SKRUE M10-30 12.9 DELTA B	SCHRAUBE M10-30 12.9 DELTA B	SCREW M10-30 12.9 DELTA B
1219-0266	UNBRACOS KRUE M10-30	INNENSECHSKANTSCHRAUBE M10-30	ALLEN SCREW M10-30
1219-0322	UNBRACOS KRUE	SECHKANTSCHRAUBE	ALLEN SCREW
1219-0598	SELVSKERENDE SKRUE M6-40/M6SF	SCHRAUBE M6-40/M6SF	SCREW M6-40/M6SF
1219-0602	PINOLSKRUE M10-25	SCHRAUBE M10-25	SCREW M10-25
1219-0603	SELVSKERENDE SKRUE M8-15 M6-SF	BLECHSCHRAUBE M8-15 M6-SF	SCREW M8-15 M6-SF
1219-0604	PINOLSKRUE M12-12	SCHRAUBE M12-12	SCREW M12-12
1220-1323	NYLOC MØTRIK M6	NYLOC MUTTER M6	NYLOC NUT M6
1220-2321	NYLOC MØTRIK M8	NYLOC MUTTER M8	NYLOC NUT M8
1220-3321	NYLOC MØTRIK M10	NYLOC MUTTER M10	NYLOC NUT M10
1220-3323	NYLOC MØTRIK M10 KVAL 10.9	NYLOC MUTTER M10 Q. 10.9	NYLOC NUT M10 Q. 10.9
1220-3922	MØTRIK M10	MUTTER M10	NUT M10
1220-3924	MØTRIK M10	MUTTER M10	NUT M10
1220-4321	NYLOC MØTRIK M12	NYLOC MUTTER M12	NYLOC NUT M12
1220-4323	NYLOC MØTRIK M12 KV 10	NYLOC MUTTER M12 Q 10	NYLOC NUT M12 Q 10
1220-5122	STÅLMØTRIK M16	STAHLMUTTER M16	STEEL NUT M16
1220-5321	NYLOC MØTRIK M16	NYLOC MUTTER M16	NYLOC NUT M16
1220-6122	STÅLMØTRIK M20	STAHLMUTTER M20	STEEL NUT M20
1220-6321	NYLOC MØTRIK M20	NYLOC MUTTER M20	NYLOC NUT M20
1220-7325	NYLOC MØTRIK M24-1,5	NYLOC MUTTER M24-1,5	NYLOC NUT M24-1,5
1241-1202	SPENDESKIVE 8,4-16-1,6	SCHIEBE 8,4-16-1,6	WASHER 8,4-16-1,6
1241-1203	SPENDESKIVE 6,5-13-1,2	SCHIEBE 6,5-13-1,2	WASHER 6,5-13-1,2
1241-1206	SPENDESKIVE 6,4-18-1,6	SCHIEBE 6,4-18-1,6	WASHER 6,4-18-1,6
1241-1304	SPENDESKIVE 8-22-1,5	SCHIEBE 8-22-1,5	WASHER 8-22-1,5
1241-1502	SPENDESKIVE 8,5-30-3	SCHIEBE 8,5-30-3	WASHER 8,5-30-3
1241-2202	SPENDESKIVE 12-18-1,5	SCHIEBE 12-18-1,5	WASHER 12-15-1,5
1241-2402	SPENDESKIVE 10,5-20-2,0	SCHIEBE 10,5-20-2,0	WASHER 10,5-20-2,0
1241-2502	SPENDESKIVE 10,5-22-3	SCHIEBE 10,5-22-3	WASHER 10,5-22-3
1241-2602	SPENDESKIVE 10-22-4,5	SCHIEBE 10-22-4,5	WASHER 10-22-4,5
1241-3403	SPENDESKIVE 13-25-2,5	SCHIEBE 13-25-2,5	WASHER 13-25-2,5
1241-4403	SPENDESKIVE 17,5-35-2	SCHIEBE 17,5-35-2	WASHER 17,5-35-2
1241-4502	SPENDESKIVE 17-30-3 STÅL	SCHIEBE 17-30-3 STAHL	WASHER 17-30-3 STEEL
1241-4503	SPENDESKIVE 17,5-35-3	SCHIEBE 17,5-35-3	WASHER 17,5-35-3
1241-4601	SPENDESKIVE 17,5-42-4	SCHIEBE 17,5-42-4	WASHER 17,5-42-4
1241-5503	SPENDESKIVE 21,0-42-3,5	SCHIEBE 21,0-42-3,5	WASHER 21,0-42-3,5
1241-6409	SPENDESKIVE 25,5-39-2,5	SCHIEBE 25,5-39-2,5	WASHER 25,5-39-2,5
1241-6701	SPENDESKIVE 26,5-50-5	SCHIEBE 26,5-50-5	WASHER 26,5-50-5
1241-7401	SPENDESKIVE 34,5-45-2,5	SCHIEBE 34,5-45-2,5	WASHER 34,5-45-2,5
1242-3621	TANDSKIVE M10 UDVENDIG	ZAHNSCHIEBE M10 AUSSEN	SPROCKET WASHER M10 OUTER
1251-2104	SPENDESTIFT 4-26	SPANNSTIFT 4-26	SPECIAL PIN 4-26
1251-3201	SPENDESTIFT 5-30	SPANNSTIFT 5-30	SPECIAL PIN 5-30
1251-3202	SPENDESTIFT 5-36	SPANNSTIFT 5-36	SPECIAL PIN 5-36
1251-3301	SPENDESTIFT 5-40	SPANNSTIFT 5-40	SPECIAL PIN 5-40
1251-3302	SPENDESTIFT 5-45	SPANNSTIFT 5-45	SPECIAL PIN 5-45
1251-3401	SPENDESTIFT 5-50	SPANNSTIFT 5-50	SPECIAL PIN 5-50
1251-3501	SPENDESTIFT 5-60	SPANNSTIFT 5-60	SPECIAL PIN 5-60
1251-4202	SPENDESTIFT 6-36	SPANNSTIFT 6-36	SPECIAL PIN 6-36
1251-4801	SPENDESTIFT 6-90	SPANNSTIFT 6-90	SPECIAL PIN 6-90
1251-5303	SPENDESTIFT 8-40	SPANNSTIFT 8-40	SPECIAL PIN 8-40
1251-5304	SPENDESTIFT 8-45	SPANNSTIFT 8-45	SPECIAL PIN 8-45
1251-5401	SPENDESTIFT 7-50	SPANNSTIFT 7-50	SPECIAL PIN 7-50
1251-5403	SPENDESTIFT 8-50	SPANNSTIFT 8-50	SPECIAL PIN 8-50
1251-5503	SPENDESTIFT 8-60	SPANNSTIFT 8-60	SPECIAL PIN 8-60
1251-5602	SPENDESTIFT 8-70	SPANNSTIFT 8-70	SPECIAL PIN 8-70

GMS-0020/2		NUMMERNØGLE FOR MONTERINGSDELE - NUMMERSLÅSSEL FØR MONTAGEZUBEHØR	
		NUMBER KEY FOR ASSEMBLY PARTS - LISTE DE PIÈCES DE MONTAGE	
VARENUMMER	BENØVNELSE	BEZEICHNUNG	DESIGNATION
1251-5701	SPENDESTIFT 7-80	SPANNSTIFT 7-80	SPECIAL PIN 7-80
1251-6802	SPENDESTIFT 10-90	SPANNSTIFT 10-90	SPECIAL PIN 10-90
1251-7301	SPENDESTIFT 12-40	SPANNSTIFT 12-40	SPECIAL PIN 12-40
1251-7401	SPENDESTIFT 12-50	SPANNSTIFT 12-50	SPECIAL PIN 12-50
1251-7701	SPENDESTIFT 12-80	SPANNSTIFT 12-80	SPECIAL PIN 12-80
1251-8601	SPENDESTIFT 14-70	SPANNSTIFT 14-70	SPECIAL PIN 14-70
1251-8803	SPENDESTIFT 16-90	SPANNSTIFT 16-90	SPECIAL PIN 16-90
1252-3102	SPLIT 4-25	SPLINT 4-25	COTTER PIN 4-25
1252-4102	SPLIT 5-25	SPLINT 5-25	COTTER PIN 5-25
1252-4201	SPLIT 5-30	SPLINT 5-30	COTTER PIN 5-30
1254-2102	FJEDERSPLIT 5 MM	FEDERSPLINT 5 MM	SPRING PIN 5 MM
1254-3201	SIKRINGSSPLIT 8 MM	FEDERSPLINT 8 MM	SECURING PIN 8 MM
1254-4201	SIKRINGSSPLIT 10 MM	FEDERSPLINT 10 MM	SECURING PIN 10 MM
1255-2205	LÅSERING 28 MM UDVENDIG	SICHERUNGSRING 28 MM AUSSEN	SNAP RING 28 MM OUTER
1311-8533	KUGELHANE	KUGELHAHN	BALL TAP
1313-1101	SMØRNIPEL	SCHMIERNIPPEL	GREASE NIPPLE
1313-2101	SMØRNIPEL	SCHMIERNIPPEL	GREASE NIPPLE
1313-3101	SMØRNIPEL	SCHMIERNIPPEL	GREASE NIPPLE
1317-0208	KOBBERPANNING 17-22-1,5	KUPFERDICHTUNG 17-22-1,5	COPPER GASKET 17-22-1,5
1323-9326	SKIVE 7,5MM	SCHIEBE 7,5MM	WASHER 7,5MM
1338-0126	PASFEDER 12-8-60	FEDERKEIL 12-8-60	FLAT KEY 12-8-60
1339-0112	STÅLKUGLE 1/2''	STAHLKUGLE 1/2''	STEEL BALL 1/2''
1431-2195	TRYKFJEDER	DRUCKFEDER	COMPRESSION SPRING
1433-0298	LÅSEFJEDER	SPERRFEDER	LOCKING SPRING
1434-0101	TALLERKENFJEDER 28-10,2-1	TELLERFEDER 28-10,2-1	DISC SPRING 28-10,2-1
1434-0108	TALLERKENFJEDER 20,0-40-2,5	TELLERFEDER 20,0-40-2,5	DISC SPRING 20,0-40-2,5

GMS-0020/2

NUMMERNØGLE - NUMMERSCHLUSSEL - NUMBER KEY - LISTE DES NUMEROS

GMS-0020/2

NUMMERNØGLE - NUMMERSCHLUSSEL - NUMBER KEY - LISTE DES NUMEROS

VARENUMMER	FIGUR	POS.	VARENUMMER	FIGUR	POS.	VARENUMMER	FIGUR	POS.	VARENUMMER	FIGUR	POS.
1165-0190	1.	18.	1315-9913	31.	11.	1340-9082	40.	27.	1501-0010	80.	4.
1213-2222	31.	37.	1315-9918	31.	15.	1340-9082	42.	27.	1501-0022	40.	51.
1213-3224	31.	2.	1315-9919	31.	16.	1340-9096	40.	99.	1501-0022	42.	51.
1214-5430	81.	43.	1315-9920	31.	17.	1340-9118	41.	0.	1501-0022	42.	54.
1214-6422	81.	24.	1315-9921	31.	18.	1340-9135	42.	11.	1501-0022	80.	51.
1219-0208	7.	8.	1315-9922	31.	19.	1340-9135	43.	0.	1501-0108	80.	26.
1219-0210	7.	3.	1315-9923	31.	20.	1340-9135	80.	11.	1501-0109	80.	25.
1219-0227	7.	9.	1315-9924	31.	21.	1340-9153	40.	21.	1501-0113	40.	25.
1219-0809	8.	5.	1315-9925	31.	23.	1340-9153	42.	21.	1501-0113	42.	25.
1220-6321	81.	25.	1315-9926	31.	24.	1340-9155	80.	21.	1501-0117	40.	26.
1241-9508	1.	7.	1315-9927	31.	26.	1340-9168	80.	28.	1501-0117	42.	26.
1251-9007	40.	24.	1315-9928	31.	27.	1340-9200	41.	10.	2010-394X	1.	32.
1251-9007	42.	24.	1315-9929	31.	28.	1340-9475	80.	29.	2061-002X	2.	13.
1251-9007	80.	24.	1315-9930	31.	29.	1341-9160	43.	11.	2062-341X	1.	14.
1255-2203	5.	13.	1315-9931	31.	30.	1341-9162	41.	14.	2062-777X	1.	2.
1255-4201	31.	22.	1315-9932	31.	31.	1341-9188	40.	22.	2080-678X	3.	22.
1255-4202	5.	2.	1315-9933	31.	33.	1341-9188	42.	22.	2080-707X	5.	4.
1255-5101	5.	12.	1315-9934	31.	35.	1341-9188	80.	22.	2081-039X	9.	5.
1255-5203	5.	18.	1315-9935	31.	38.	1341-9189	43.	15.	2083-083X	1.	6.
1255-6101	43.	9.	1315-9936	31.	39.	1341-9189	80.	31.	2083-282X	81.	6.
1255-7102	30.	28.	1317-0208	3.	23.	1341-9305	80.	57.	2083-283X	81.	7.
1311-2601	1.	33.	1317-0302	1.	35.	1341-9308	80.	55.	2083-373X	5.	25.
1311-2601	3.	29.	1317-0302	3.	32.	1341-9411	40.	52.	2083-408X	4.	11.
1311-2601	81.	13.	1317-0302	81.	15.	1341-9411	42.	52.	2083-409X	4.	17.
1311-2602	1.	37.	1317-0303	81.	11.	1341-9411	80.	52.	2083-410X	4.	14.
1311-2602	3.	25.	1317-0462	3.	16.	1341-9436	43.	10.	2083-411X	4.	15.
1311-8401	81.	37.	1317-0482	81.	35.	1341-9523	40.	12.	2083-497X	1.	19.
1311-8519	3.	14.	1317-0483	1.	30.	1341-9523	42.	13.	2083-794X	1.	17.
1311-8522	3.	17.	1317-0484	3.	28.	1341-9523	80.	13.	2083-958X	81.	32.
1311-8525	1.	31.	1317-0715	1.	34.	1341-9524	41.	2.	2083-964X	81.	33.
1311-8533	1.	39.	1317-0715	3.	30.	1341-9524	43.	2.	2085-703X	8.	3.
1311-8533	3.	27.	1317-0715	81.	12.	1341-9561	41.	12.	2085-704X	8.	1.
1311-8534	1.	40.	1317-9263	3.	34.	1341-9562	41.	13.	2085-706X	7.	41.
1311-8536	2.	16.	1317-9273	1.	43.	1341-9569	41.	11.	2085-707X	7.	42.
1311-8566	3.	24.	1317-9274	3.	33.	1341-9587	43.	13.	2085-708X	7.	47.
1311-8580	81.	14.	1317-9805	81.	29.	1341-9618	40.	54.	2085-709X	7.	43.
1311-8583	1.	38.	1321-3304	3.	6.	1341-9618	42.	53.	2085-710X	7.	45.
1311-8583	3.	26.	1321-5308	3.	4.	1341-9618	80.	54.	2085-711X	7.	46.
1311-8587	81.	38.	1322-3103	3.	7.	1341-9630	40.	53.	2085-712X	7.	48.
1315-9109	31.	5.	1322-5101	3.	5.	1341-9630	80.	53.	2085-714X	7.	49.
1315-9110	31.	25.	1323-4301	3.	11.	1341-9641	40.	55.	2085-715X	7.	50.
1315-9226	31.	13.	1323-5402	3.	3.	1341-9641	42.	55.	2085-716X	7.	51.
1315-9245	31.	32.	1323-9556	50.	10.	1341-9641	80.	58.	2085-717X	7.	10.
1315-9272	31.	10.	1323-9637	50.	3.	1341-9643	41.	9.	2085-718X	7.	15.
1315-9339	31.	6.	1323-9638	50.	5.	1341-9644	41.	15.	2085-719X	7.	11.
1315-9349	31.	14.	1323-9639	50.	6.	1341-9647	80.	59.	2085-720X	7.	12.
1315-9385	31.	34.	1323-9640	50.	7.	1341-9649	80.	56.	2085-721X	7.	13.
1315-9598	30.	6.	1323-9641	50.	9.	1341-9733	43.	12.	2085-723X	7.	16.
1315-9599	30.	4.	1323-9644	50.	8.	1350-0145	8.	8.	2085-724X	7.	14.
1315-9600	30.	2.	1324-8313	50.	0.	1362-9804	4.	16.	2085-729X	7.	7.
1315-9671	7.	17.	1331-3302	5.	10.	1380-0013	8.	4.	2085-731X	7.	18.
1315-9804	30.	36.	1331-4105	5.	17.	1380-0228	7.	0.	2085-733X	7.	6.
1315-9819	30.	32.	1331-5304	5.	3.	1392-0507	5.	7.	2085-735X	7.	19.
1315-9820	30.	31.	1331-7408	1.	27.	1393-0110	4.	13.	2085-739X	7.	40.
1315-9821	30.	30.	1331-9907	50.	4.	1393-0110	10.	8.	2085-750X	7.	52.
1315-9822	30.	29.	1331-9932	30.	19.	1393-0138	3.	31.	2085-751X	7.	53.
1315-9824	30.	27.	1331-9994	31.	12.	1393-0138	81.	16.	2086-179X	83.	3.
1315-9825	30.	26.	1332-4801	30.	23.	1393-0139	1.	41.	2086-180X	83.	5.
1315-9826	30.	25.	1332-4801	31.	40.	1393-0139	81.	30.	2086-484X	83.	2.
1315-9829	30.	21.	1332-4802	30.	24.	1393-0140	1.	36.	2086-829X	6.	21.
1315-9830	30.	20.	1335-5502	1.	20.	1393-0140	81.	31.	2086-829X	83.	9.
1315-9832	30.	18.	1335-5503	5.	9.	1393-0141	81.	17.	2086-935X	83.	8.
1315-9833	30.	17.	1335-5524	3.	8.	1393-0162	6.	9.	2086-936X	83.	4.
1315-9834	30.	16.	1335-5535	1.	2.	1393-0170	1.	13.	2086-940X	1.	3.
1315-9835	30.	15.	1338-0102	31.	36.	1393-0170	4.	7.	2086-943X	83.	6.
1315-9836	30.	14.	1338-0106	1.	45.	1399-0124	81.	19.	2087-671X	83.	11.
1315-9837	30.	13.	1338-0126	4.	18.	1399-0150	1.	12.	2088-566X	9.	2.
1315-9838	30.	12.	1339-5502	5.	28.	1399-0240	6.	7.	2089-180X	8.	7.
1315-9839	30.	11.	1340-1406	40.	0.	1421-5492	1.	21.	2210-399X	1.	24.
1315-9840	30.	10.	1340-1408	42.	0.	1421-6599	5.	1.	2210-444X	4.	1.
1315-9841	30.	9.	1340-5429	80.	0.	1421-7497	1.	22.	2210-460X	4.	4.
1315-9842	30.	8.	1340-7119	1.	42.	1431-2195	83.	10.	2210-478X	4.	2.
1315-9843	30.	7.	1340-9019	80.	27.	1432-4597	5.	6.	2210-589X	4.	19.
1315-9845	30.	5.	1340-9022	80.	23.	1433-0294	81.	18.	2210-611X	6.	19.
1315-9848	30.	1.	1340-9028	40.	11.	1433-0314	6.	20.	2210-612X	6.	17.
1315-9878	30.	35.	1340-9028	42.	12.	1434-0108	7.	44.	2213-005X	4.	12.
1315-9907	31.	1.	1340-9037	80.	30.	1434-0111	7.	54.	2213-014X	1.	26.
1315-9908	31.	3.	1340-9039	80.	12.	1501-0009	40.	5.	2213-041X	84.	3.
1315-9909	31.	4.	1340-9055	43.	14.	1501-0009	42.	5.	2213-043X	84.	4.
1315-9910	31.	7.	1340-9056	41.	16.	1501-0009	80.	5.	2223-220X	1.	5.
1315-9911	31.	8.	1340-9073	40.	23.	1501-0010	40.	4.	2225-386X	6.	12.
1315-9912	31.	9.	1340-9073	42.	23.	1501-0010	42.	4.	2225-397X	8.	10.

VARENUMMER	FIGUR	POS.	VARENUMMER	FIGUR	POS.	VARENUMMER	FIGUR	POS.	VARENUMMER	FIGUR	POS.
2225-640X	5.	30.	3213-030X	2.	9.						
2226-145X	3.	20.	3214-623X	9.	4.						
2226-177X	4.	5.	3214-702X	9.	1.						
2226-216X	2.	6.	3214-724X	8.	2.						
2226-218X	2.	3.	3214-725X	8.	6.						
2226-255X	1.	23.	3214-726X	8.	9.						
2226-394X	5.	20.	3214-892X	6.	4.	1					
2226-550X	10.	2.	3226-109X	4.	8.						
2226-594A	3.	18.	3226-129X	5.	5.						
2226-595A	3.	21.	3226-130X	5.	8.						
2226-603X	2.	17.	3226-182X	4.	9.						
2226-830A	4.	10.	3226-213X	2.	5.						
2226-900X	5.	19.	3226-553X	10.	3.						
2226-915X	2.	15.	3226-554X	10.	4.						
2227-750X	2.	7.	3226-559X	10.	7.						
2228-208X	1.	4.	3227-872X	30.	0.						
2228-246X	82.	2.	3228-095X	5.	11.						
2228-268X	82.	3.	3228-324X	2.	14.						
2228-331X	5.	24.	3228-372X	10.	6.						
2228-332X	5.	27.	3228-390X	3.	12.						
2228-341X	3.	13.	3228-487X	5.	15.						
2228-355X	2.	8.	3228-489X	5.	26.						
2228-377X	4.	3.	3228-620X	81.	9.						
2228-465X	3.	19.	3228-621X	81.	3.						
2228-482X	3.	15.	3228-630X	81.	23.						
2228-490X	6.	1.	3228-784A	6.	5.	1					
2228-491X	10.	1.	3228-784X	6.	5.						
2228-492X	10.	5.	3228-860X	1.	25.						
2228-625X	81.	2.	3228-917X	2.	11.						
2228-706X	1.	29.	3228-983X	81.	10.						
2228-707X	81.	22.	3228-984X	81.	8.						

FIGURNØGLE - FIGURSCHLÜSSEL - FIGURE KEY - LISTE DE FIGURES

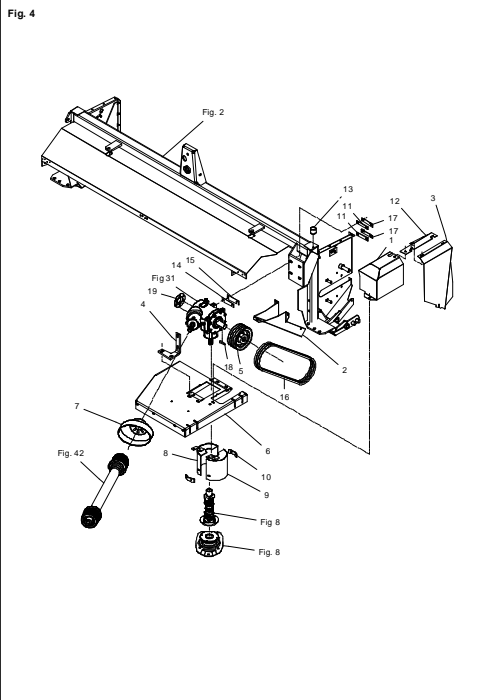
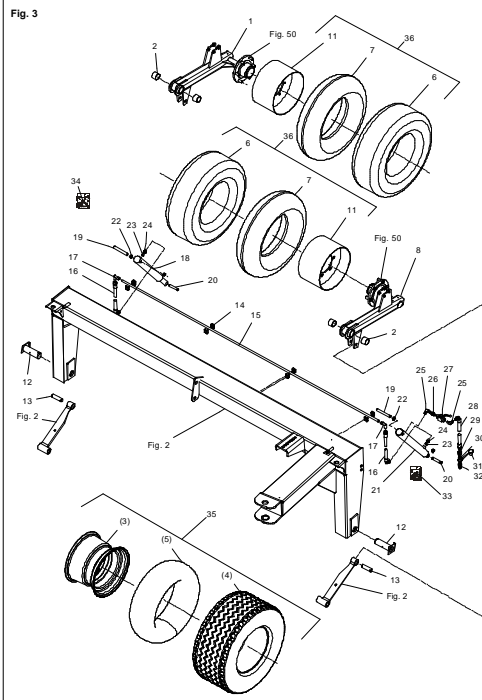
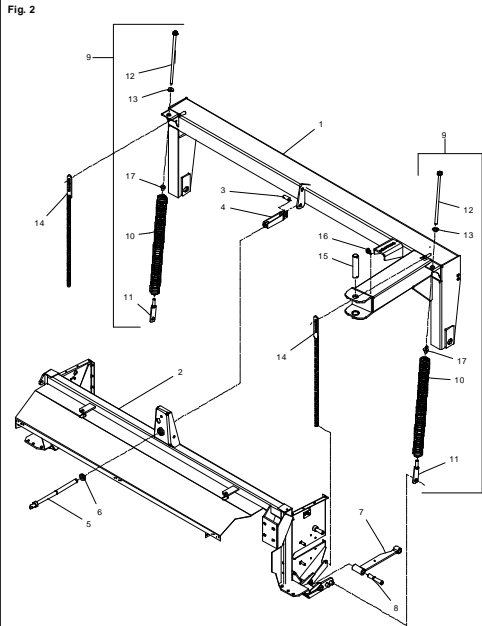
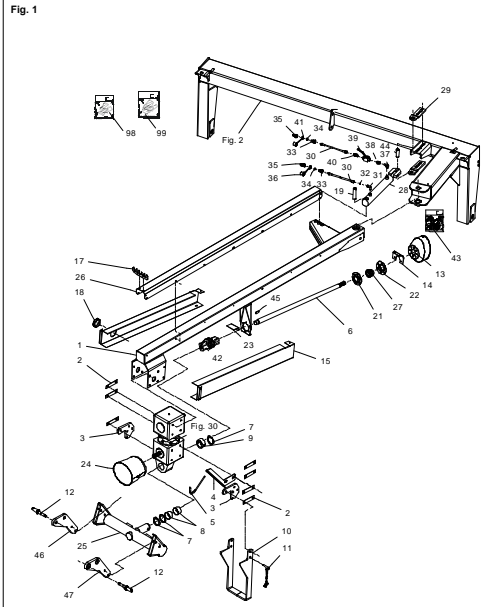

FIGURNØGLE - FIGURSCHLÜSSEL - FIGURE KEY - LISTE DE FIGURES

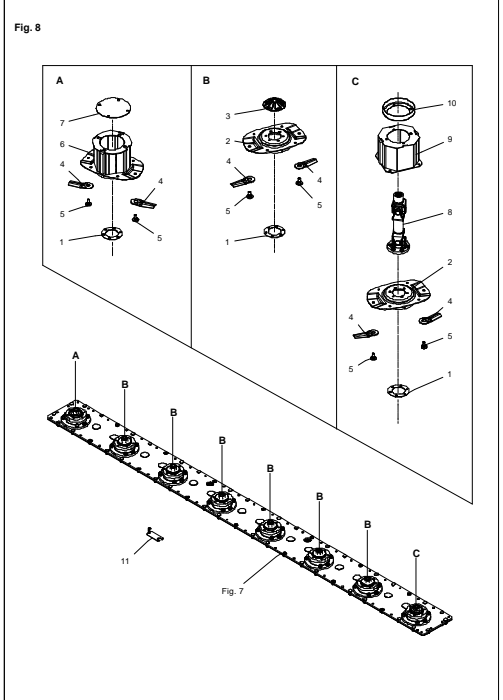
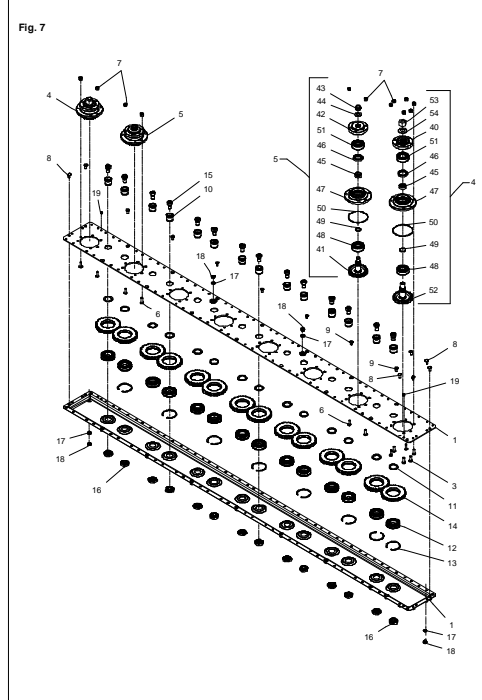
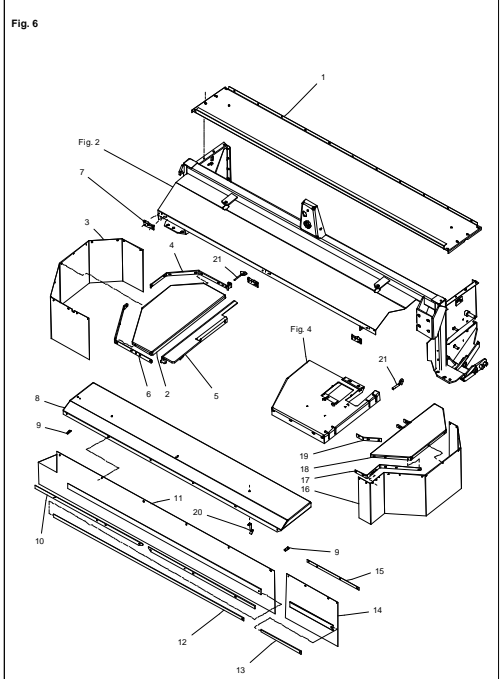
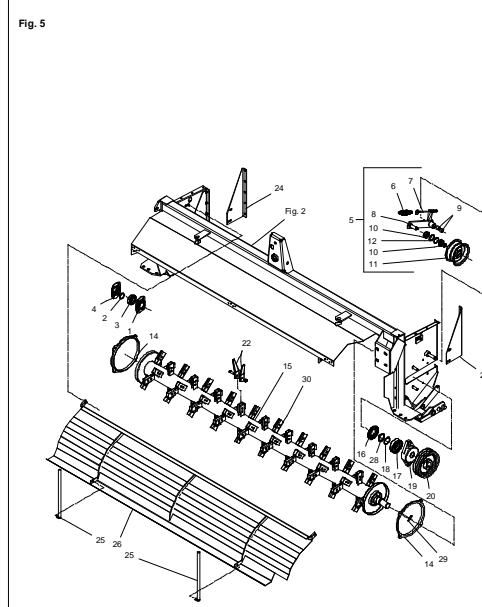

FIGURNØGLE - FIGURSCHLÜSSEL - FIGURE KEY - LISTE DE FIGURES

Fig. 9

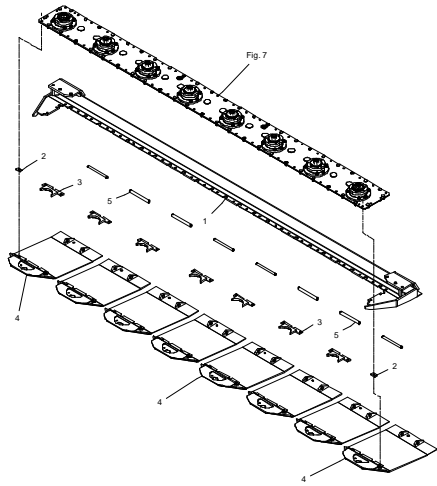

Fig. 10

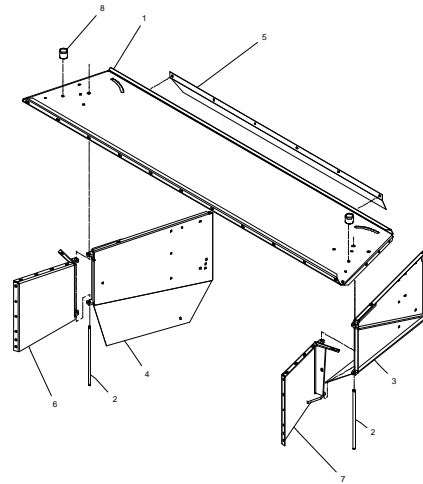

Fig. 30

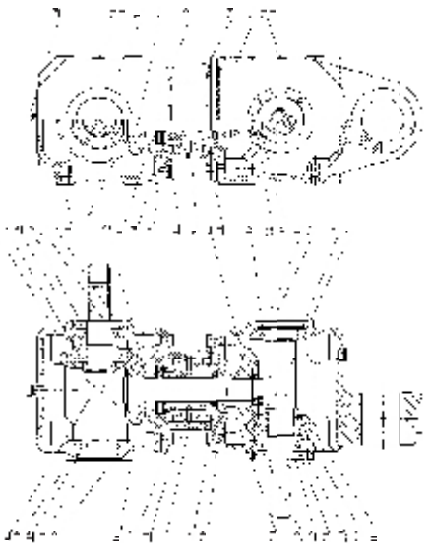
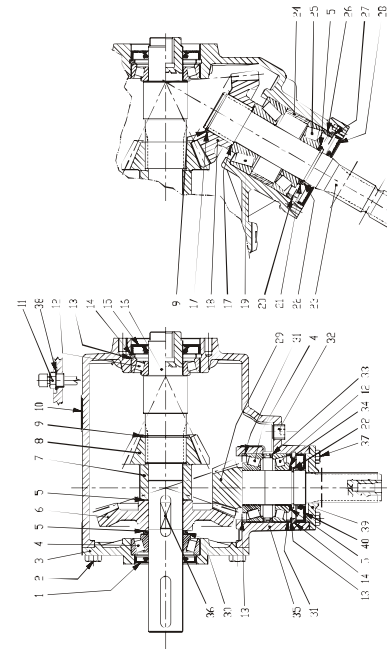

Fig. 31



FIGURNØGLE - FIGURSCHLÜSSEL - FIGURE KEY - LISTE DE FIGURES

Fig. 40

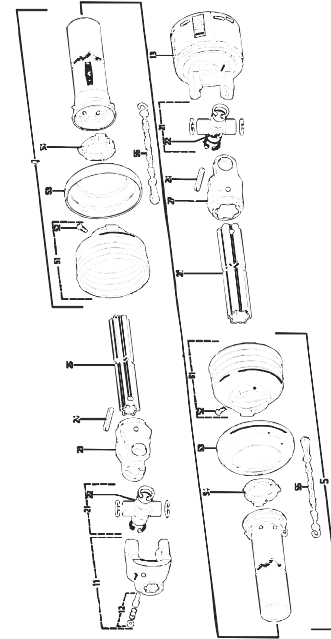

Fig. 41

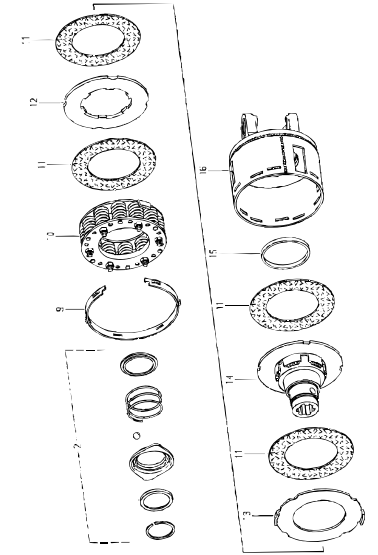

Fig. 42

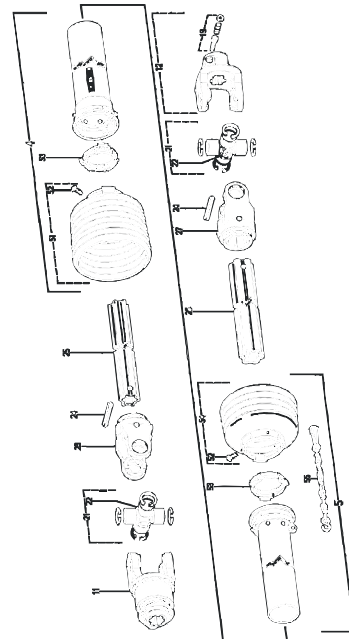
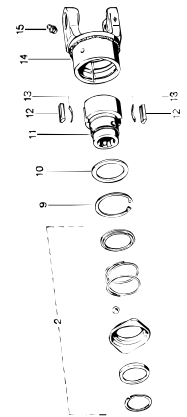
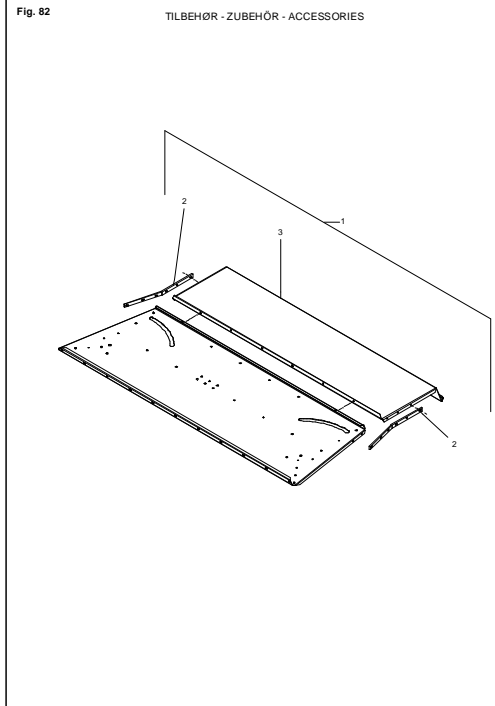
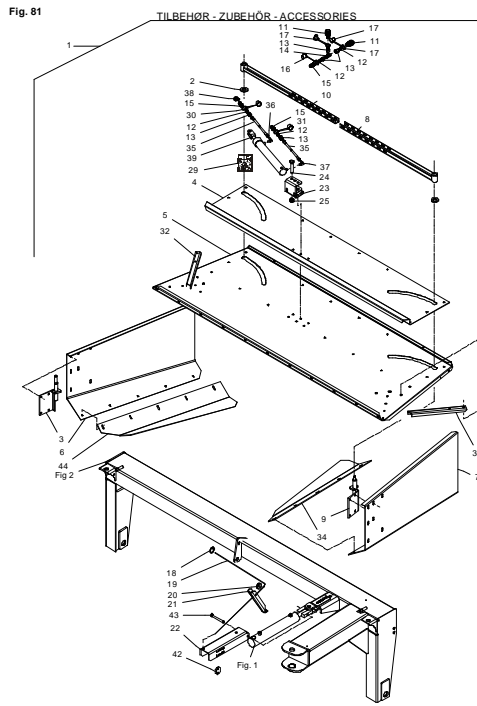
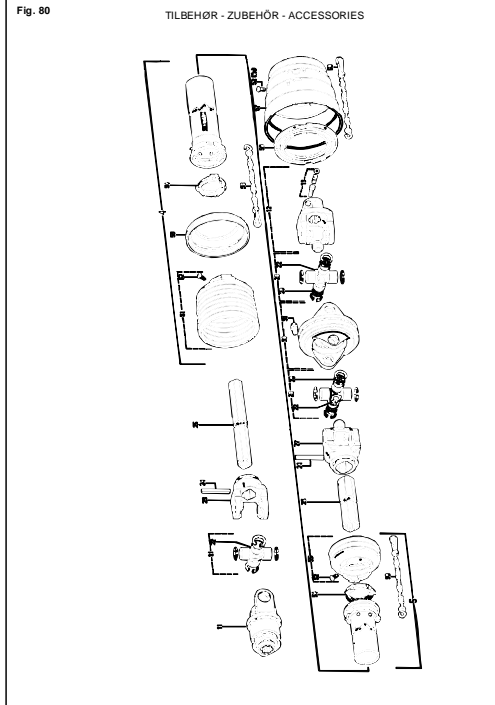
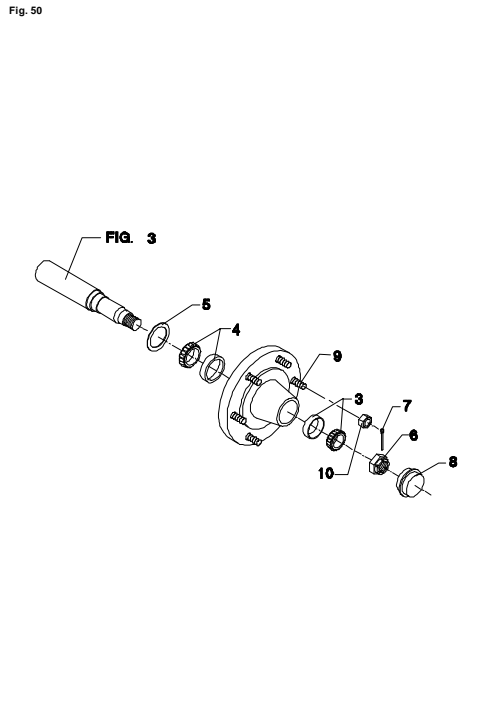

Fig. 43





FIGURNØGLE - FIGURSCHLÜSSEL - FIGURE KEY - LISTE DE FIGURES



FIGURNØGLE - FIGURSCHLÜSSEL - FIGURE KEY - LISTE DE FIGURES

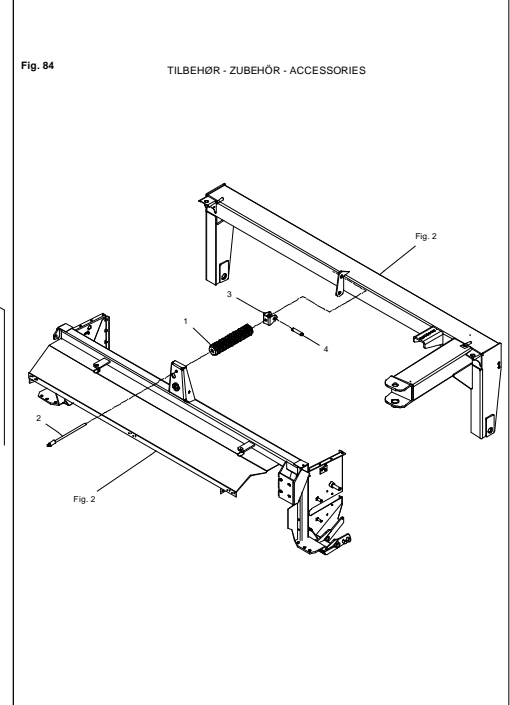
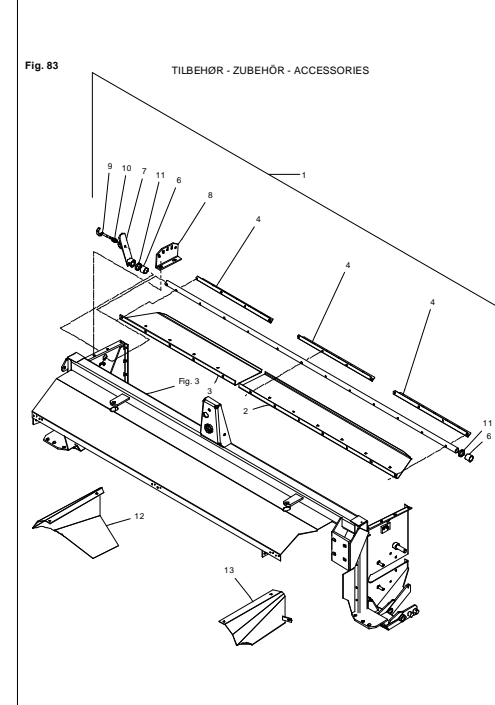
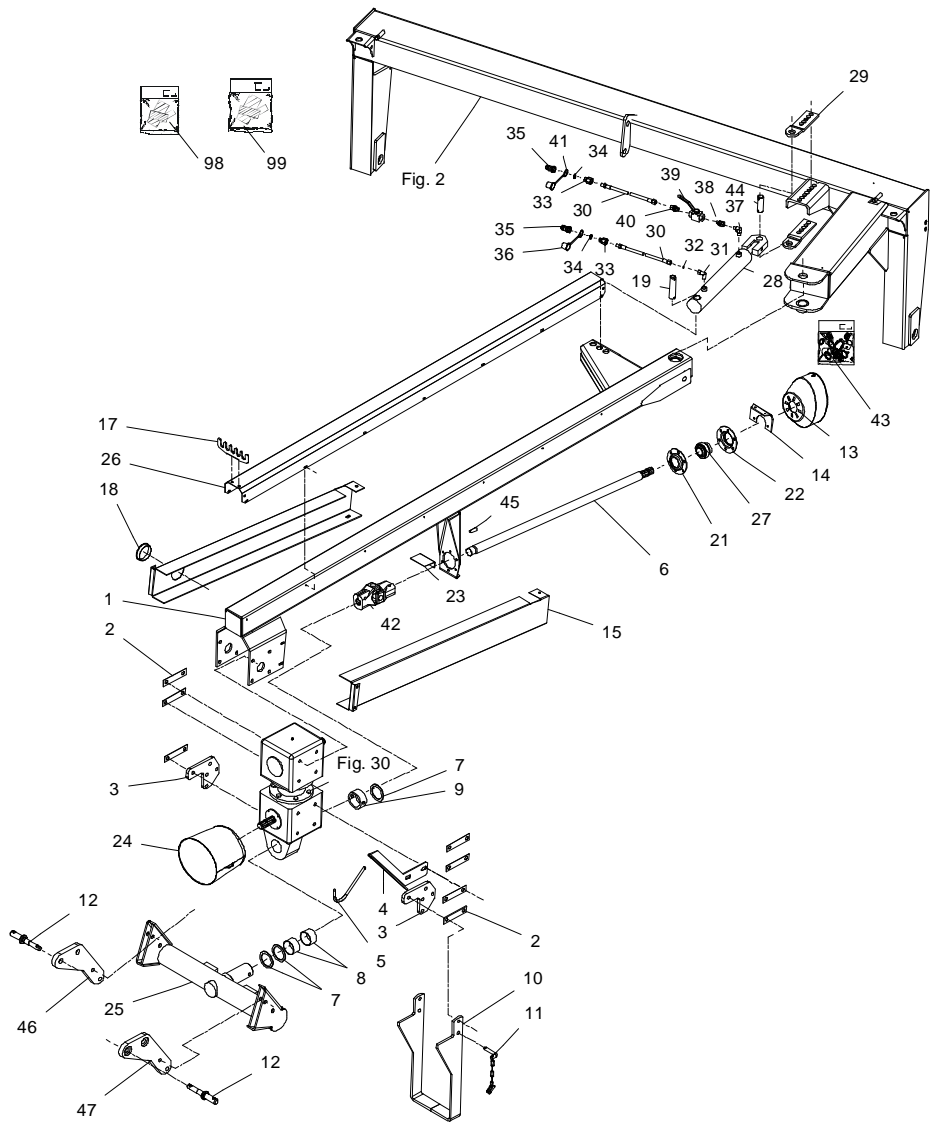



Fig. 1



GMS-0020/2 GMS 320 C

FIG. 1.

>=2130111647

POS.	VARENUMMER	ANTAL	BENEVNELSE	BEZEICHNUNG	DESIGNATION	HERTIL, DAZU, TO THIS, A CECI
1.	3213-012X	1	TRÆKSTANG ZUGSTANGE		DRAWBAR	
2.	2062-777X	7	LÅSEBLIK SPERRBLECH		STRIKING PLATE	1213-5420 12
3.	2086-940X	2	KONSOL KONSOLE		BRACKET	
4.	2228-208X	1	KONSOL KONSOLE		BRACKET	1213-5422 2
5.	2223-220X	1	BØJLE BUEGEL		HOOP	1241-3403 1 1252-3102 1
6.	2083-083X	1	AKSEL WELLE		SHAFT	
7.	1241-9508	3	STØTTESKIVE 70-90-3,5 STUETZCHEIBE 70-90-3,5		SUPPORT WASHER 70-90-3,5	
8.	1335-5524	2	GLIDELEJE 70-75-40 GLEITLAGER 70-75-40		PLAIN BEARING 70-75-40	
9.	2228-861X	1	BØSNING BUCHSE		BUSH	
10.	3210-736X	1	STØTTEFOD STUETZE		SUPPORT	1213-5422 2 1220-5122 2
11.	3191-083X	1	TAP ZAPFEN		DOWEL	
12.	1399-0150	2	KOBLINGSTAP - DIN 17.200 KUPPLUNGZAPFEN		DOWEL	1220-7325 1 1241-6701 1 1254-4201 1
13.	1393-0170	1	SKERM FOR PTO SCHUTZ FUER PTO		GUARD FOR PTO	1213-3224 3 1241-3403 3
14.	2062-341X	1	SKERMHOLDER SCHUTZHALTER		GUARDHOLDER	1213-3224 4 1220-3321 2 1241-3403 4
15.	2228-712X	1	SKERM SCHUTZ		GUARD	1213-3224 2 1241-2502 2
16.	2228-711X	1	SKERM SCHUTZ		GUARD	1213-3224 2 1220-3922 2 1241-2502 2
17.	2083-794X	1	SLANGEHOLDER KLEMMBUEGEL		CLAMP HOOP	1213-3222 2 1220-3321 2
18.	1165-0190	1	AFDEKNING ABDECKUNG		COVER	
19.	2083-497X	1	TAP ZAPFEN		DOWEL	1251-3302 2 1251-5304 2
20.	1335-5502	2	GLIDELEJE 45-50-50 GLEITLAGER 45-50-50		PLAIN BEARING 45-50-50	
21.	1421-5492	1	LEJESHALVPART LAGERGEHAEUSEHAELFTE		HALF OF BEARING HOUSING	
22.	1421-7497	1	LEJESHALVPART LAGERGEHAEUSEHAELFTE		HALF OF BEARING HOUSING	1313-1101 1
23.	2226-255X	1	PLADE FLATTE		PLATE	
24.	2210-399X	1	PTO-SKERM, OVAL PTO-SCHUTZ, OVAL		PTO-GUARD, OVAL	
25.	3228-860X	1	TRÆK ANTRIEB		DRIVE	1251-4801 1 1251-6802 1 1251-8803 1
26.	2213-014X	1	SKERM SCHUTZ		GUARD	1219-0603 14

Fig. 1

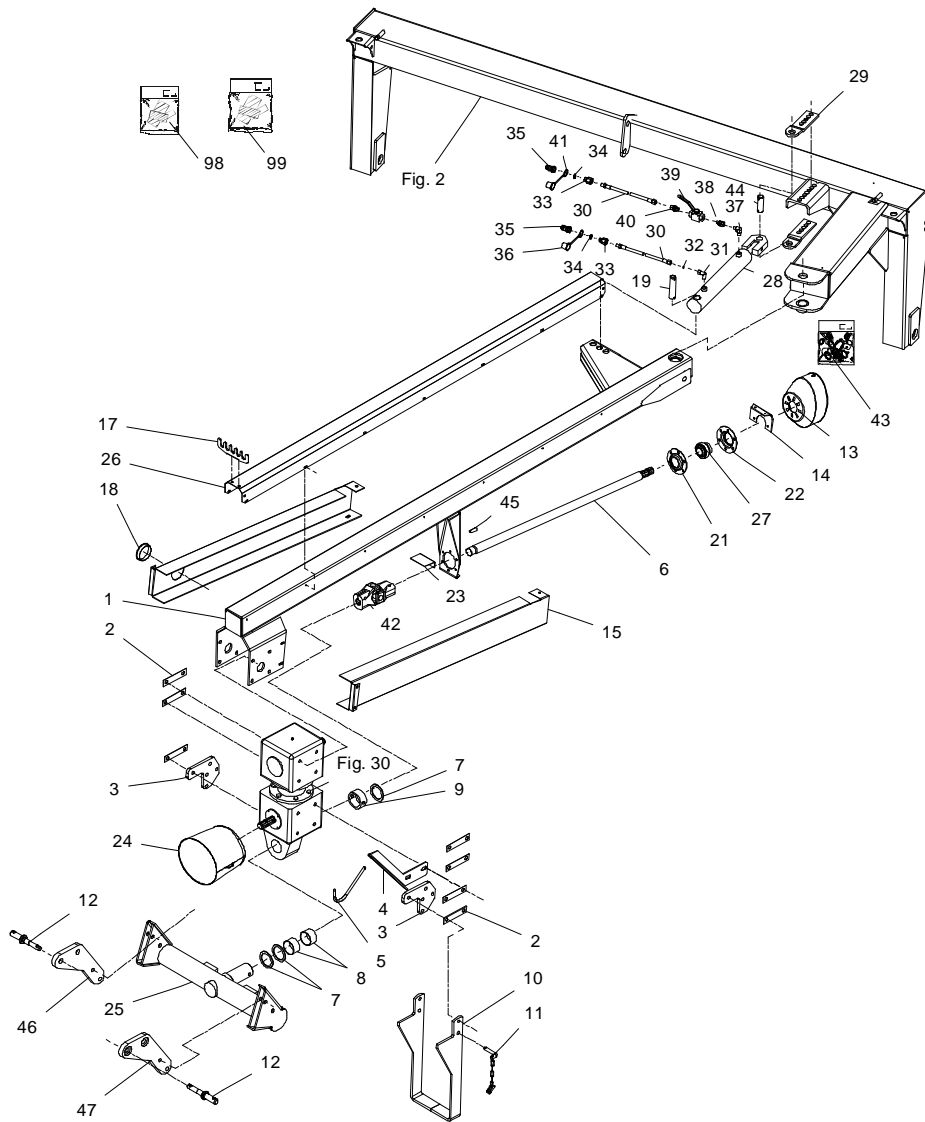

GMS-0020/2 GMS 320 C

FIG. 1.

>=2130111647

HERTIL, DAZU,  
TO THIS, A CECI

POS.	VARENUMMER	ANTAL	BENEVNELSE	BEZEICHNUNG	DESIGNATION		
27.	1331-7408	1	KUGLELEJE GE 40 KRRB CC KUGELLAGER GE 40 KRRB CC		BALL BEARING GE 40 KRRB CC		
28.	2228-714A	1	CYLINDER ZYLINDER		CYLINDER		
29.	2228-706X	2	LASKE LASCHE		FISH PLATE	1214-6322 1220-6321	2 2
30.	1317-0483	2	HYDRAKLIKSLANGE L=5200 HYDRAULISCHER SCHLAUCH L=5200		HYDRAULIC HOSE L=5200		
31.	1311-8525	1	VINKELFORSKRUNING - L10 WINKELVERSCHRAUBUNG - L10		ANGLE COUPLING - L10		
32.	2010-394X	1	DYSE DÜSE		NOZZLE		
33.	1311-2601	2	NIPPELMUFFE NIPPEL		BUSHING		
34.	1317-0715	2	O-RING O-RING		O-RING		
35.	1317-0302	2	STIK F/LYNKOBLING ANSCHLUSS F/SCHNELLKUPPLUNG		CONNECTION F/QUICK-COUPLING		
36.	1393-0140	1	BESKYTTELSESHETTE BLÅ SCHUTZKAPPE BLAU		PROTECTION CAP BLUE		
37.	1311-2602	1	VINKELNIPPEL NIPPEL		ANGLE NIPPLE		
38.	1311-8583	1	NIPPEL NIPPEL		NIPPLE		
39.	1311-8533	1	KUGLEHANE KUGELHAHN		BALL TAP	1311-8533	1
40.	1311-8534	1	FORSKRUNING VERSCHRAUBUNG		SCREWED CONNECTION		
41.	1393-0139	1	BESKYTTELSESHETTE RØD SCHUTZKAPPE ROT		PROTECTION CAP RED		
42.	1340-7119	1	KARDANLED KREUZGELENK		UNIVERSAL JOINT	1214-4326 1220-4321	1 1
43.	1317-9273	1	PAKNINGSSÆT DICHTUNGSSATZ		SET OF GASKETS		
44.	2501-441X	1	TAP ZAPFEN		DOWEL	1251-3401 1251-5403	2 2
45.	1338-0106	1	PASFEDER 12-8-45 FEDERKEIL 12-8-45		FLAT KEY 12-8-45		
46.	2229-633X	1	TREKLASKE, HØJRE ZUGLASCHE, RECHTER		COUPLING PLATE, RIGHT	1214-6226 1220-6122	1 1
47.	2229-634X	1	TREKLASKE, VENSTRE ZUGLASCHE, LINKE		COUPLING PLATE, LEFT	1214-6226 1220-6122	1 1
98.	3889-118A	1	TRANSFER F/TREKSYSTEM D TRANSFER F/ZUGSTANGE D		TRANSFER F/DRAWBAR D		
99.	3889-228X	1	TRANSFER F/GMS 320 TRANSFER F/GMS 320		TRANSFER F/GMS 320		

Fig. 2

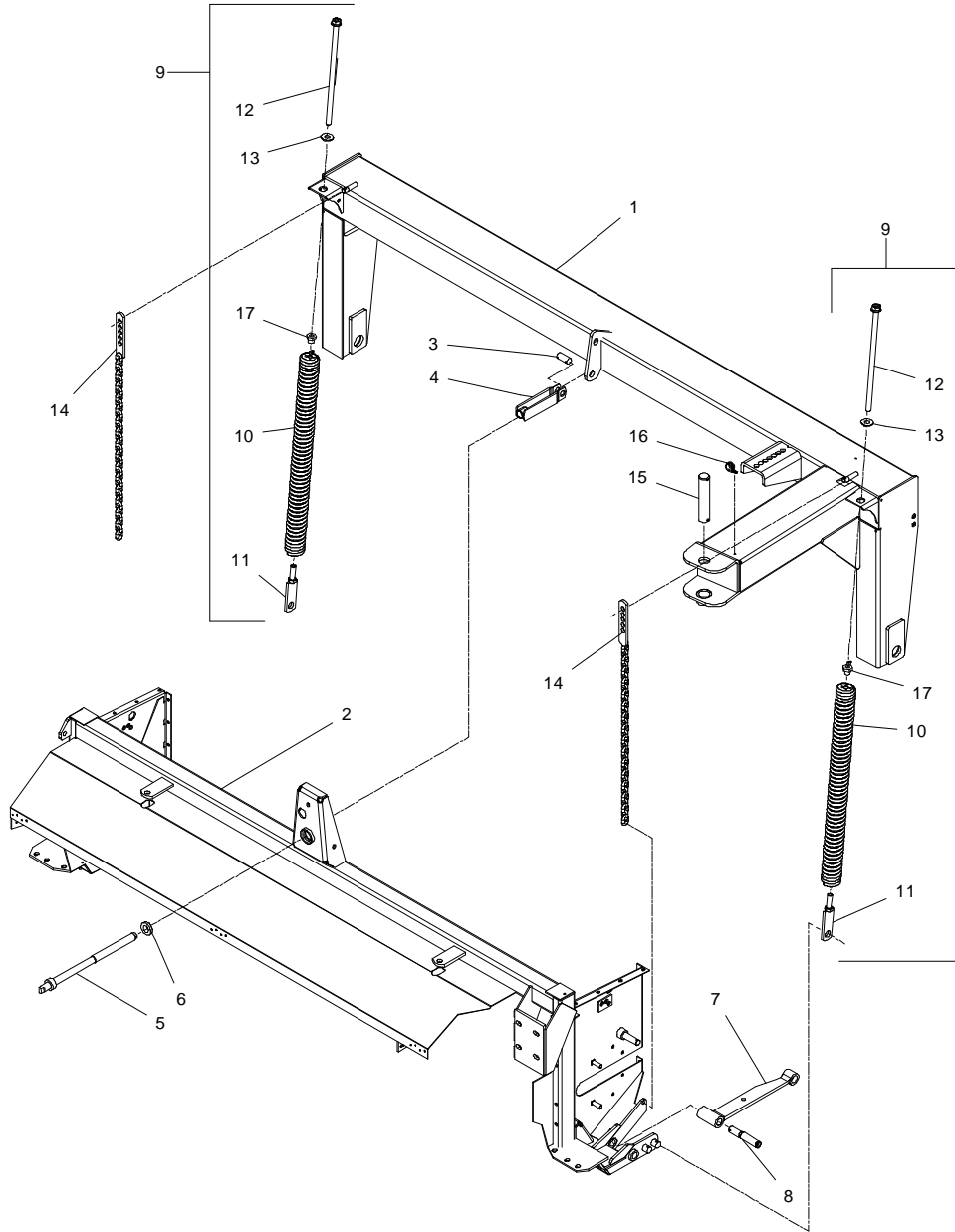

GMS-0020/2 GMS 320 C

FIG. 2.

>=2130111647

POS.	VARENUMMER	ANTAL	BENEVNELSE	BEZEICHNUNG	DESIGNATION	HERTIL, DAZU, TO THIS, A CECI	
1.	3213-020X	1	HJULRAMME RADRAHMEN		WHEEL FRAME		
2.	3213-001X	1	CRIMPERAMME CRIMPERRAHMEN		CONDITIONER FRAME		
3.	2226-218X	1	TAP ZAPFEN		DOWEL	1251-4202	2
4.	3083-011X	1	MØTRIK MUTTER		NUT		
5.	3226-213X	1	SPINDEL SPINDEL		SPINDLE	1254-2102	1
6.	2226-216X	1	KUGLE KUGEL		BALL		
7.	2227-750X	1	STANG STANGE		BAR		
8.	2228-355X	1	TAP ZAPFEN		DOWEL	1251-3302 1251-5304 1255-2205	1 1 1
9.	3213-030X	2	FJEDER SAMLET FEDER GESAMMELT		SPRING ASSEMBLING	1241-7401 1251-3301 1251-5303	1 1 1
10.	3083-206X	2	TRÆKFJEDER SML. ZUGFEDER		TENSION SPRING	1313-3101	1
11.	3228-917X	2	HOLDER HALTER		SUPPORT	1241-5503	1
12.	3213-006X	2	STILLESKRUE JUSTIERSCHRAUBE		REGULATING SCREW	1434-0108	1
13.	2061-002X	2	KONISK SKIVE KON.SCHEIBE		CONICAL WASHER		
14.	3228-324X	2	KEDEINDSTILLING KETTENEINSTELLUNG		CHAIN ADJUSTMENT	1213-4327 1220-4323 1241-3403 1254-3201	2 2 2 2
15.	2226-915X	1	TAP ZAPFEN		DOWEL	1251-3501 1251-5503	2 2
16.	1311-8536	2	SLANGHOLDER KLEMMBUEGEL		CLAMPING HOOP		
17.	2226-603X	2	MØTRIK MUTTER		NUT		

Fig. 3

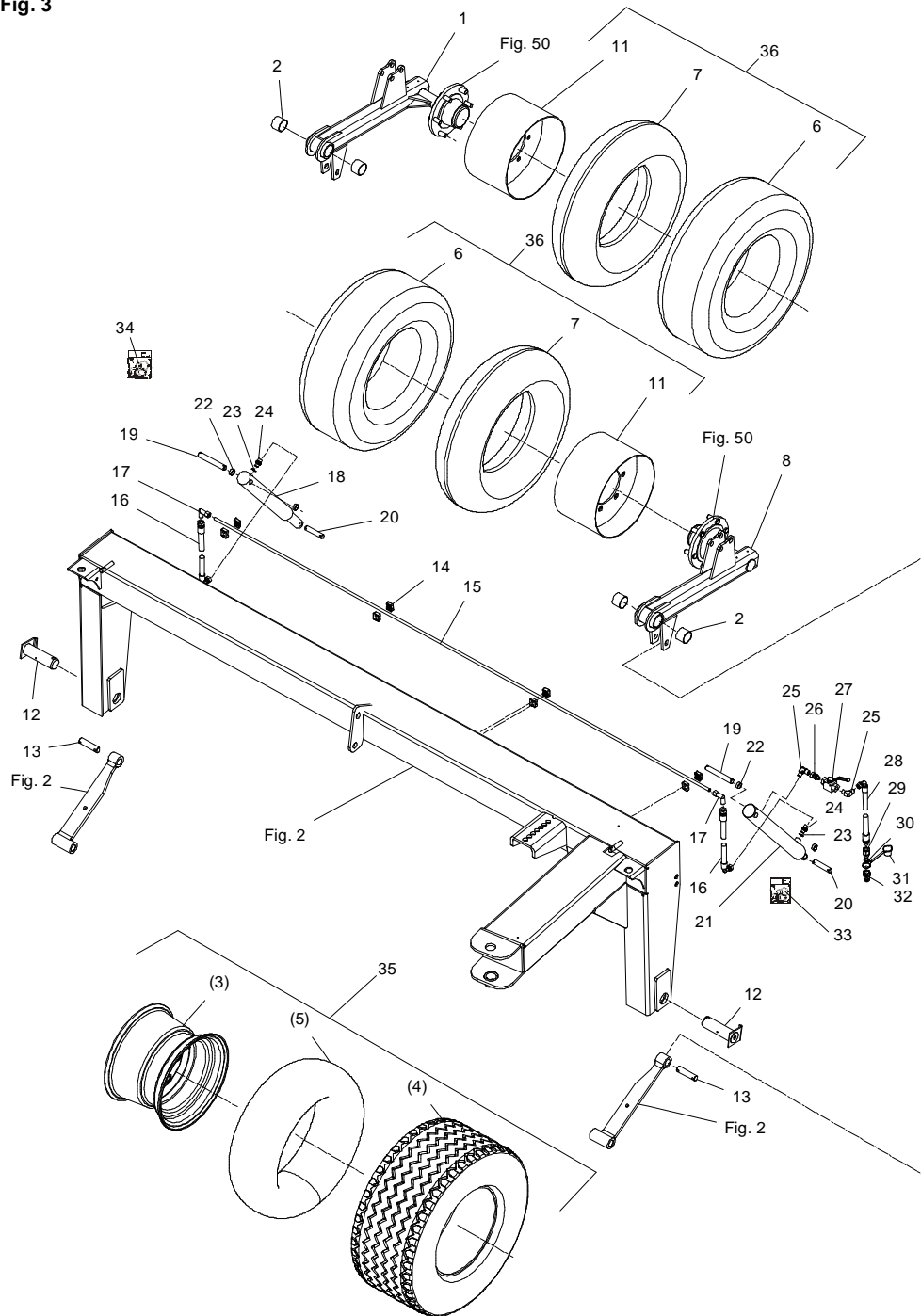

GMS-0020/2 GMS 320 C

FIG. 3.

>=213011647

HERTIL, DAZU,  
TO THIS, A CECI

POS.	VARENUMMER	ANTAL	BENEVNELSE	BEZEICHNUNG	DESIGNATION		
1.	3229-979X	1	HJULHOLDER, HØJRE RADHALTERUNG, RECHTE		HOLDER FOR WHEEL, RIGHT		
2.	1335-5535	4	GLIDELEJE 50-55-40 GLEITLAGER 50-55-40		PLAIN BEARING 50-55-40		
3.	1323-5402	T	FÆLG 11,00-16 30MM FORSETNING FELGE 11,00-16 30MM VERSETZUNG		RIM 11,00-16 30MM OFFSET		
4.	1321-5308	T	DEK 13.0/55-16 REIFEN 13.0/55-16		TYRE 13.0/55-16		
5.	1322-5101	T	SLANGE 1350-16 SCHLAUCH 1350-16		TUBE 1350-16		
6.	1321-3304	2	DEK 260/70-15.3 REIFEN 260/70-15.3		TYRE 260/70-15.3		
7.	1322-3103	2	SLANGE 10.0/75-15,3 SCHLAUCH 10,0/75-15,3		TUBE 10,0/75-15,3		
8.	3229-978X	1	HJULHOLDER, VENSTRE RADHALTERUNG, LINKE		HOLDER FOR WHEEL, LEFT		
11.	1323-4301	2	FÆLG 9,00-15 10MM FORSETNING FELGE 9,00-15 10MM VERSETZUNG		RIM 9,00-15 10MM OFFSETTING		
12.	3228-390X	2	TAP ZAPFEN		DOWEL	1251-5602	1
						1251-8601	1
						1313-1101	1
13.	2228-341X	2	TAP ZAPFEN		DOWEL	1251-3301	1
						1251-5303	1
14.	1311-8519	4	RØRHOLDER ROHRHALTERUNG		SUPPORT FOR TUBE		
15.	2228-482X	1	RØR ROHR		TUBE	1219-0598	4
						1241-1206	4
16.	1317-0462	2	HYDRAULIK SLANGE L= 470 HYDRAULISCHER SCHLAUCH L=470		HYDRAULIC HOSE L= 470		
17.	1311-8522	2	VINKELFORSKRUNING WINKELVERSCHRAUBUNG		ANGLE COUPLING		
18.	2226-594A	1	CYLINDER ZYLINDER		CYLINDER		
19.	2228-465X	2	TAP ZAPFEN		DOWEL	1241-5503	2
						1251-3201	2
20.	2226-145X	2	TAP ZAPFEN		DOWEL		
21.	2226-595A	1	CYLINDER ZYLINDER		CYLINDER		
22.	2080-678X	4	AFSTANDSRØR DISTANZROHR		DISTANCE TUBE		
23.	1317-0208	2	KOBBERPAKNING 17-22-1,5 KUPFERDICHTUNG 17-22-1,5		COPPER GASKET 17-22-1,5		
24.	1311-8566	2	NIPPEL NIPPEL		NIPPLE		
25.	1311-2602	2	VINKELNIPPEL NIPPEL		ANGLE NIPPLE		
26.	1311-8583	1	NIPPEL NIPPEL		NIPPLE		
27.	1311-8533	1	KUGLEHANE KUGELHAHN		BALL TAP	1317-0208	1
28.	1317-0484	1	HYDRAULIKSLANGE L=6500 HYDRAULISCHER SCHLAUCH L=6500		HYDRAULIC HOSE L=6500		
29.	1311-2601	1	NIPPELMUFFE NIPPEL		BUSHING		

Fig. 3

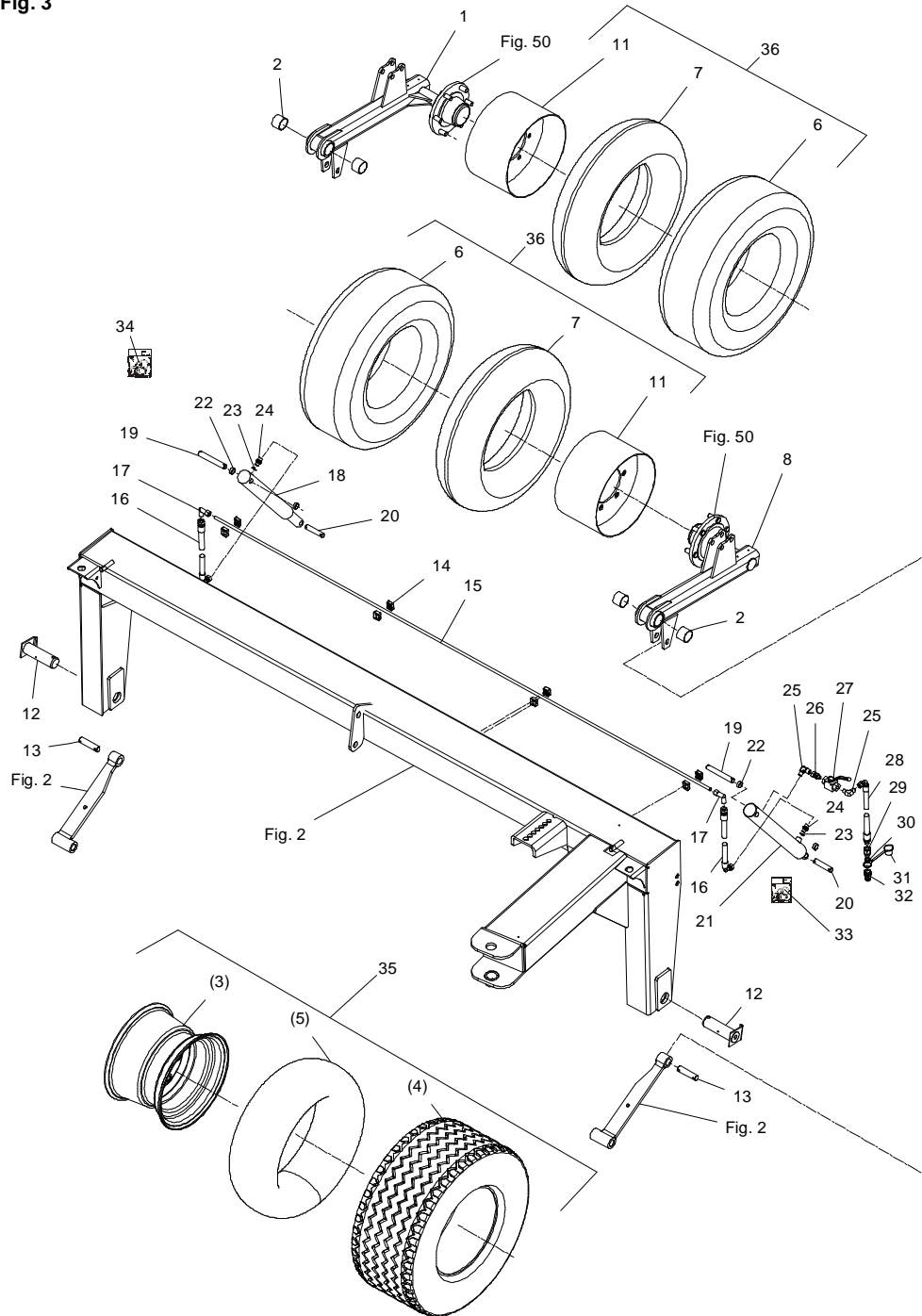

GMS-0020/2 GMS 320 C

FIG. 3.

>=213011647

HERTIL, DAZU,  
TO THIS, A CECI

POS.	VARENUMMER	ANTAL	BENEVNELSE	BEZEICHNUNG	DESIGNATION	
30.	1317-0715	1	O-RING	O-RING	O-RING	
31.	1393-0138	1	BESKYTTELSESHETTE GUL SCHUTZKAPPE GELB		PROTECTION CAP YELLOW	
32.	1317-0302	1	STIK F/LYNKOBLING ANSCHLUSS F/SCHNELLKUPPLUNG		CONNECTION F/QUICK-COUPLING	
33.	1317-9274	1	PAKNINGSSSET DICHTUNGSSATZ		SET OF GASKETS	
34.	1317-9263	1	PAKNINGSSSET DICHTUNGSSATZ		SET OF GASKETS	
35.	4000-1039	T 2	HJUL RAD		WHEEL	
36.	4000-1056	2	HJUL RAD		WHEEL	

Fig. 4

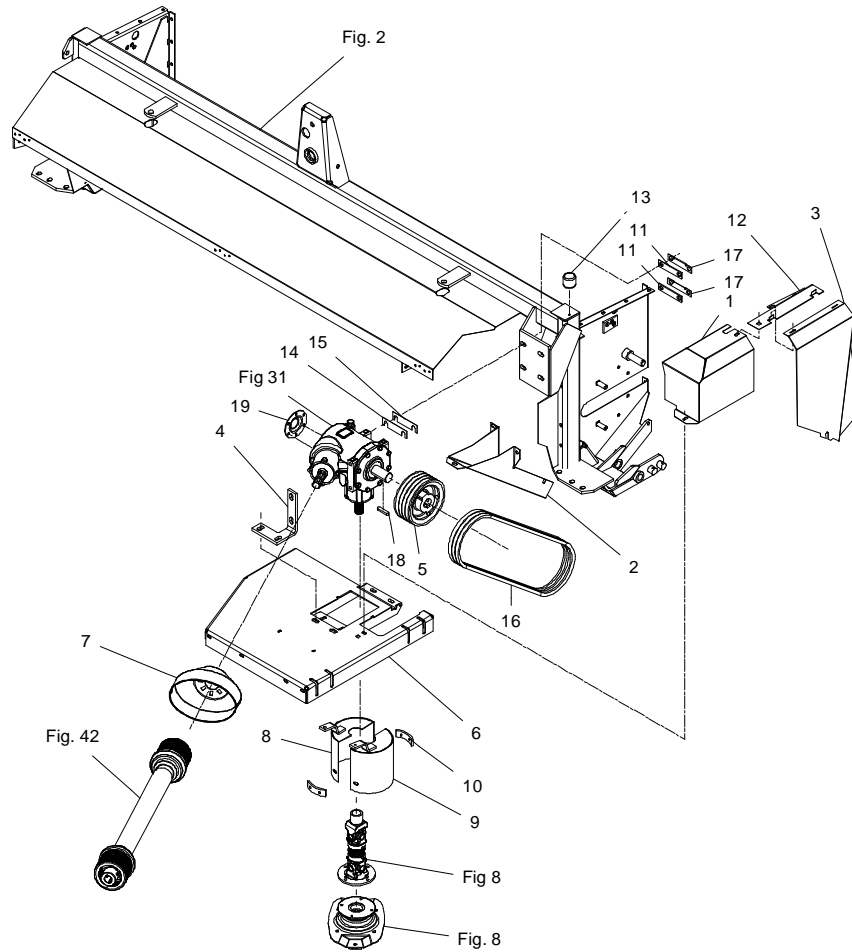

GMS-0020/2 GMS 320 C

FIG. 4.

>=2130111647

HERTIL, DAZU,  
TO THIS, A CECI

POS.	VARENUMMER	ANTAL	BENEVNELSE	BEZEICHNUNG	DESIGNATION		
1.	2210-444X	1	SKERM SCHUTZ		GUARD		
2.	2210-478X	1	SKERM SCHUTZ		GUARD	1213-3222	2
						1214-4424	2
						1220-3321	2
						1220-3922	1
						1220-4321	2
						1241-2502	4
						1241-3403	4
3.	2228-377X	1	SKERM SCHUTZ		GUARD		
4.	2210-460X	1	HOLDER HALTER		HOLDER	1213-5322	4
						1220-5122	2
						1241-4502	4
5.	2226-177X	1	REMSKIVE B195 4 SPOR KEILRIEMENSCHIEBE B195 4 SP		PULLEY B195 4 SP	1219-0604	2
						1338-0126	1
6.	3210-456X	1	SKERM SCHUTZ		GUARD	1213-3224	2
						1213-4327	2
						1220-3321	2
						1220-3924	1
						1220-4321	2
						1241-2502	2
						1241-3403	2
7.	1393-0170	1	SKERM FOR PTO SCHUTZ FUER PTO		GUARD FOR PTO	1213-2224	4
						1241-1502	4
8.	3226-109X	1	SKERM, HØJRE SCHUTZ, RECHTE		GUARD, RIGHT	1241-3403	1
9.	3226-182X	1	SKERM, VENSTRE SCHUTZ, LINKE		GUARD, LEFT	1213-4327	1
						1241-3403	1
10.	2226-830A	2	BESLAG BESCHLAG		CLAMP	1213-3222	4
						1241-2502	4
						1242-3621	4
11.	2083-408X	2	SPÆNDSTYKKE SPANNSTUECK		TIGHTENING PIECE	1213-5422	4
12.	2213-005X	1	SKERMHOLDER SCHUTZHALTER		GUARD HOLDER		
13.	1393-0110	1	GUMMIBUFFE GUMMIBUFFER		RUBBER BUFFER	1219-0602	1
14.	2083-410X	1	MELLEMLEG ZWISCHENLAGE		FILLER		
15.	2083-411X	1	MELLEMLEG ZWISCHENLAGE		FILLER		
16.	1362-9804	1	REMSSET (3 STK.) RIEMENSATZ (3 STCK.)		V-BELT SET (3 PCS.)		
17.	2083-409X	2	LÅSEBLIK SPERRBLECH		STRIKING PLATE		
18.	1338-0126	1	PASFEDER 12-8-60 FEDERKEIL 12-8-60		FLAT KEY 12-8-60		
19.	2210-589X	1	LUKKEPLADE VERSCHLISSPLATTE		LOCKING PLATE	1213-3224	6

Fig. 5

GMS-0020/2 GMS 320 C

FIG. 5.

>=2130111647

HERTIL, DAZU,  
TO THIS, A CECI

POS.	VARENUMMER	ANTAL	BENEVNELSE	BEZEICHNUNG	DESIGNATION		
1.	1421-6599	1	LEJEHUSHALVPART LAGERGEHAEUSEHAELFTE		HALF OF BEARING HOUSING	1313-1101	1
2.	1255-4202	1	LÅSERING 45 MM UDVENDIG SICHERINGSRING 45 MM AUSSEN		SNAP RING 45 MM OUTER		
3.	1331-5304	1	KUGLELEJE 172-6209 2RS C3 KUGELLAGER 172-6209 2RS C3		BALL BEARING 172-6209 2RS C3		
4.	2080-707X	1	LEJEHUS LAGERGEHAEUSE		BEARING HOUSING	1220-4323 1241-3403	4 4
5.	3226-129X	1	REMSSTRAMMER RIEMENSPANNER		BELT TIGHTENER	1241-6409 1251-3202	2 1
6.	1432-4597	1	TRÆKFJEDER ZUGFEDER		TENSION SPRING		
7.	1392-0507	1	ØJEBOLT M10 GALV AUGBOLZEN M10 GALV		EYE BOLT M10 GALV	1220-3323	1
8.	3226-130X	1	REMSSTRAMMER RIEMENSPANNER		BELT TIGHTENER	1313-2101	1
9.	1335-5503	2	GLIDELEJE 25-28-20 GLEITLAGER 25-28-20		PLAIN BEARING 25-28-20		
10.	1331-3302	2	KUGLELEJE KUGELLAGER		BALL BEARING		
11.	3228-095X	1	STRAMMERULLE SPANNROLLE		TIGHTENING ROLLER		
12.	1255-5101	1	LÅSERING 52 MM INDVENDIG SICHERINGSRING 52 MM INNEN		SNAP RING 52 MM INNER		
13.	1255-2203	1	LÅSERING 25 MM UDVENDIG SICHERINGSRING 25 MM AUSSEN		SNAP RING 25 MM OUTER		
14.	2320-295X	2	RING RING		RING	1215-2222 1220-2321 1241-1304	4 4 4
15.	3228-487X	1	ROTOR ROTOR		ROTOR		
16.	3060-054X	1	TÆTNING DICHTUNG		TIGHTENING		
17.	1331-4105	1	KUGLELEJE 6311 KUGELLAGER 6311		BALL BEARING 6311		
18.	1255-5203	1	LÅSERING 55 MM UDVENDIG SICHERINGSRING 55 MM AUSSEN		SNAP RING 55 MM OUTER		
19.	2226-900X	1	FLANGELEJE FLANCSLAGER		FLANGE BEARING	1220-5321 1241-4503 1313-2101	2 2 1
20.	2226-394X	1	REMSKIVE 3-SPB-225 RIEMENSCHIEBE 3-SPB-225		PULLEY 3-SPB-225	1251-5701 1251-7701	1 1
22.	3229-782X	1	10 STK. 2225-518X/2225-519X 10 STCK. 2225-518X/2225-519X		10 PCS. 2225-518X/2225-519X	1214-4126 1220-4323	1 1
24.	2228-331X	1	AFSTIVNING STÜBTZE		SUPPORT	1213-3224 1220-3321 1241-2502	2 2 2
25.	2083-373X	2	JUSTERBOLT STELLBOLZEN		ADJUSTING BOLT	1220-5122 1220-5321 1241-4503 1252-4102 1323-9326	2 1 2 1 2
26.	3228-489X	1	TRYKPLADE DRUCKPLATTE		COMPRESSION	1215-5522 1220-5321 1241-4503	2 2 2

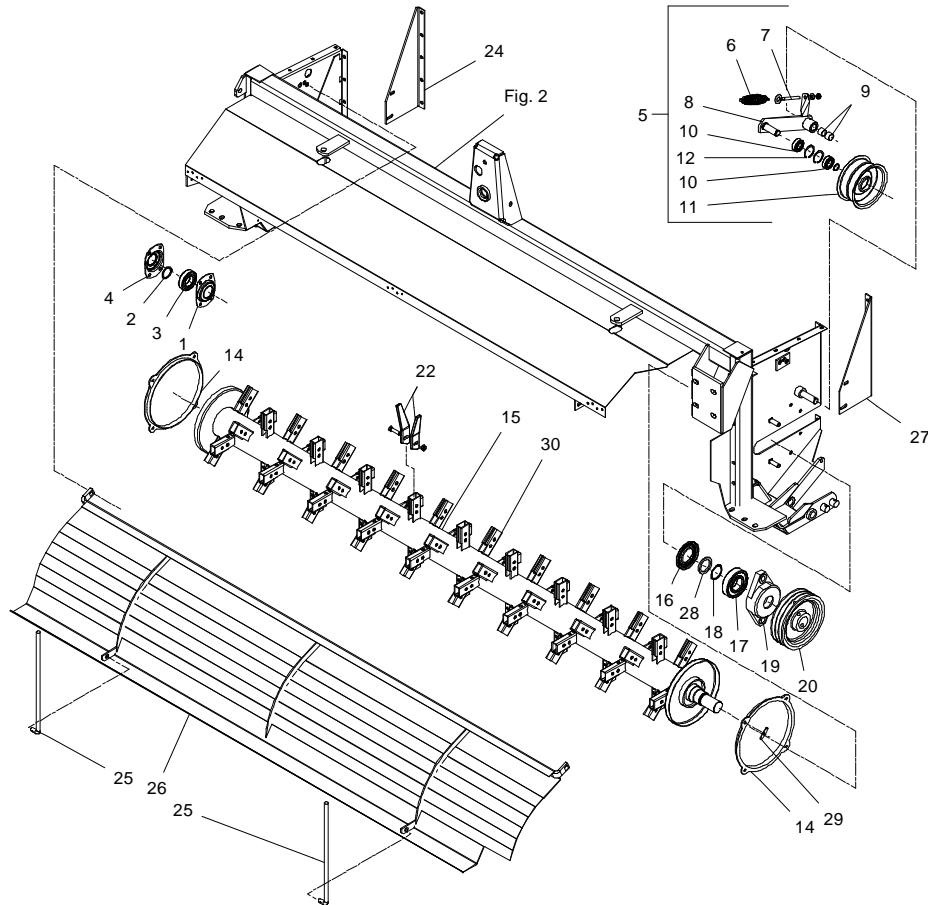



Fig. 5

GMS-0020/2 GMS 320 C

FIG. 5.

>=213011647

HERTIL, DAZU,  
TO THIS, A CECI

POS.	VARENUMMER	ANTAL	BENEVNELSE	BEZEICHNUNG	DESIGNATION		
27.	2228-332X	1	AFSTIVNING STUETZE		SUPPORT	1213-3224	2
						1220-3321	2
						1241-2502	2
28.	1339-5502	1	FILTRING 55-71-6 FILZRING 55-71-6		FELT RING 55-71-6		
29.	2320-271X	8	TILHOLDER HALTER		HOLDER		
30.	2225-640X	76	KONSOL KONSOLE		BRACKET		

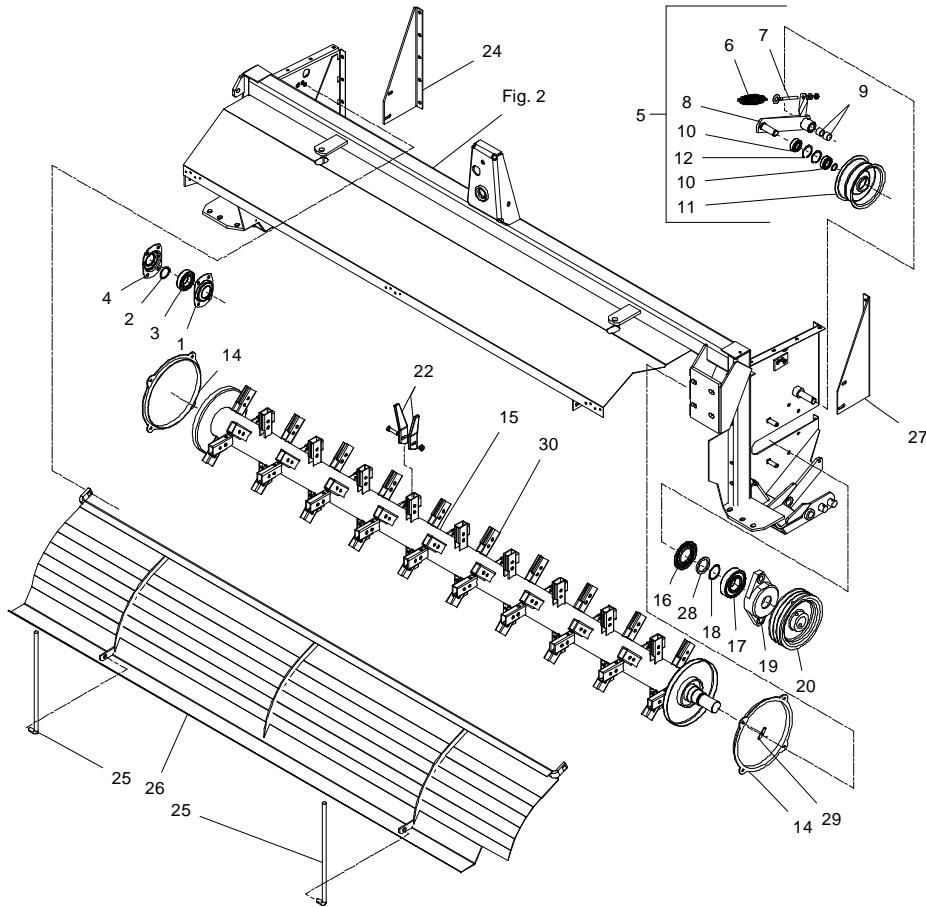
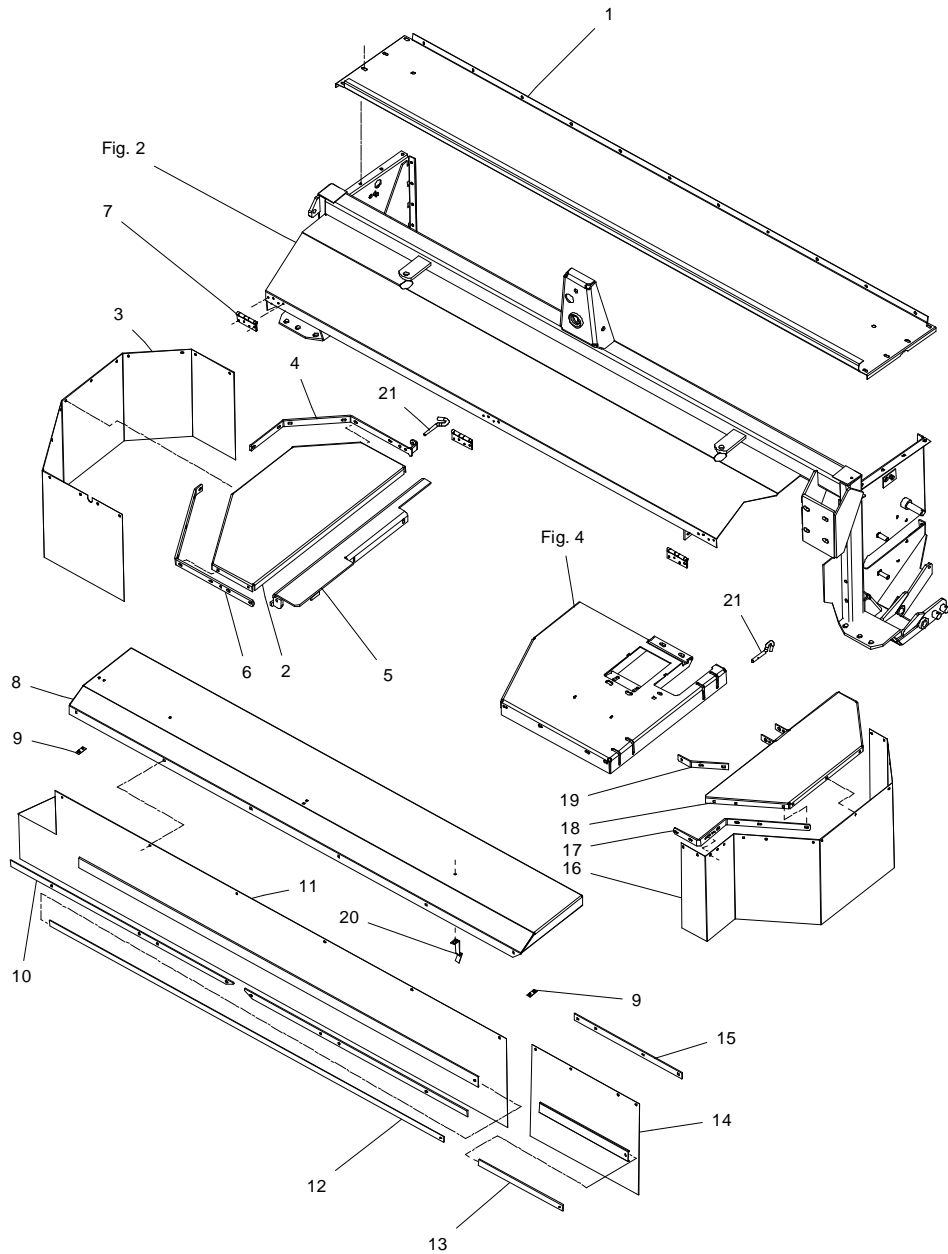

Fig. 6



GMS-0020/2 GMS 320 C

FIG. 6.

>=2130111647

HERTIL, DAZU,  
TO THIS, A CECI

POS.	VARENUMMER	ANTAL	BENEVNELSE	BEZEICHNUNG	DESIGNATION			
1.	2228-490X	1	TOPPLADE TOPPLATTE		TOP PLATE	1213-3222	8	
						1220-3321	8	
						1241-2502	16	
2.	2228-767X	1	SIDESKERM SEITENWAND		SIDE GUARD			
3.	2228-763B	1	DUG TUCH		CANVAS	1215-2124	2	
						1215-2222	12	
						1220-2321	14	
						1241-1202	14	
4.	2228-775X	1	HÆNGSEL SHARNIER		HINGE	1213-3324	1	
						1215-2222	6	
						1220-2321	6	
						1220-3321	1	
						1241-1202	7	
						1434-0101	2	
4. 1	3214-892X	1	HÆNGSEL SHARNIER		HINGE	1213-3324	1	
						1215-2222	6	
						1220-2321	6	
						1220-3321	1	
						1241-1202	7	
						1434-0101	2	
5.	3228-784X	1	SKERMSTØTTE SCHUTZSTUETZE		GUARD PROTECTION	1213-3322	2	
						1220-3321	2	
						1241-2502	4	
5. 1	3228-784A	1	SKERMSTØTTE SCHUTZSTUETZE		GUARD PROTECTION	1213-3322	2	
						1220-3321	2	
						1241-2502	4	
6.	2228-774X	1	HÆNGSEL SHARNIER		HINGE	1213-3324	1	
						1215-2222	6	
						1220-2321	6	
						1220-3321	1	
						1241-1202	7	
						1434-0101	2	
7.	1399-0240	3	HÆNGSEL SCHARNIER		HINGE			
8.	2228-771X	1	SKERM SCHUTZ		GUARD	1219-0322	24	
						1220-1323	24	
						1241-1203	24	
9.	1393-0162	2	GUMMIUNDERLAG GUMMIUNTERLAGE		RUBBER BACKING			
10.	2228-773X	2	SKINNE SCHIENE		RAIL			
11.	2228-755A	1	DUG, FORRESTE TUCH, VORDERE		CANVAS, FRONT	1215-2222	6	
						1220-2321	6	
						1241-1202	6	
12.	2225-386X	1	SKINNE SCHIENE		RAIL	1213-2126	1	
						1220-2321	1	
						1241-1304	2	
13.	2228-782X	1	SKINNE SCHIENE		RAIL	1213-2126	1	
						1220-2321	1	
						1241-1304	2	
14.	2228-765B	1	DUG TUCH		CANVAS	1215-2222	4	
						1220-2321	4	
						1241-1202	4	
15.	2228-783X	1	HOLDER HALTER		SUPPORT			
16.	2228-766B	1	DUG TUCH		CANVAS	1215-2124	10	
						1215-2222	5	
						1220-2321	15	
						1241-1202	15	
17.	2210-612X	1	HOLDER F/DUG HALTER		SUPPORT			

Fig. 6

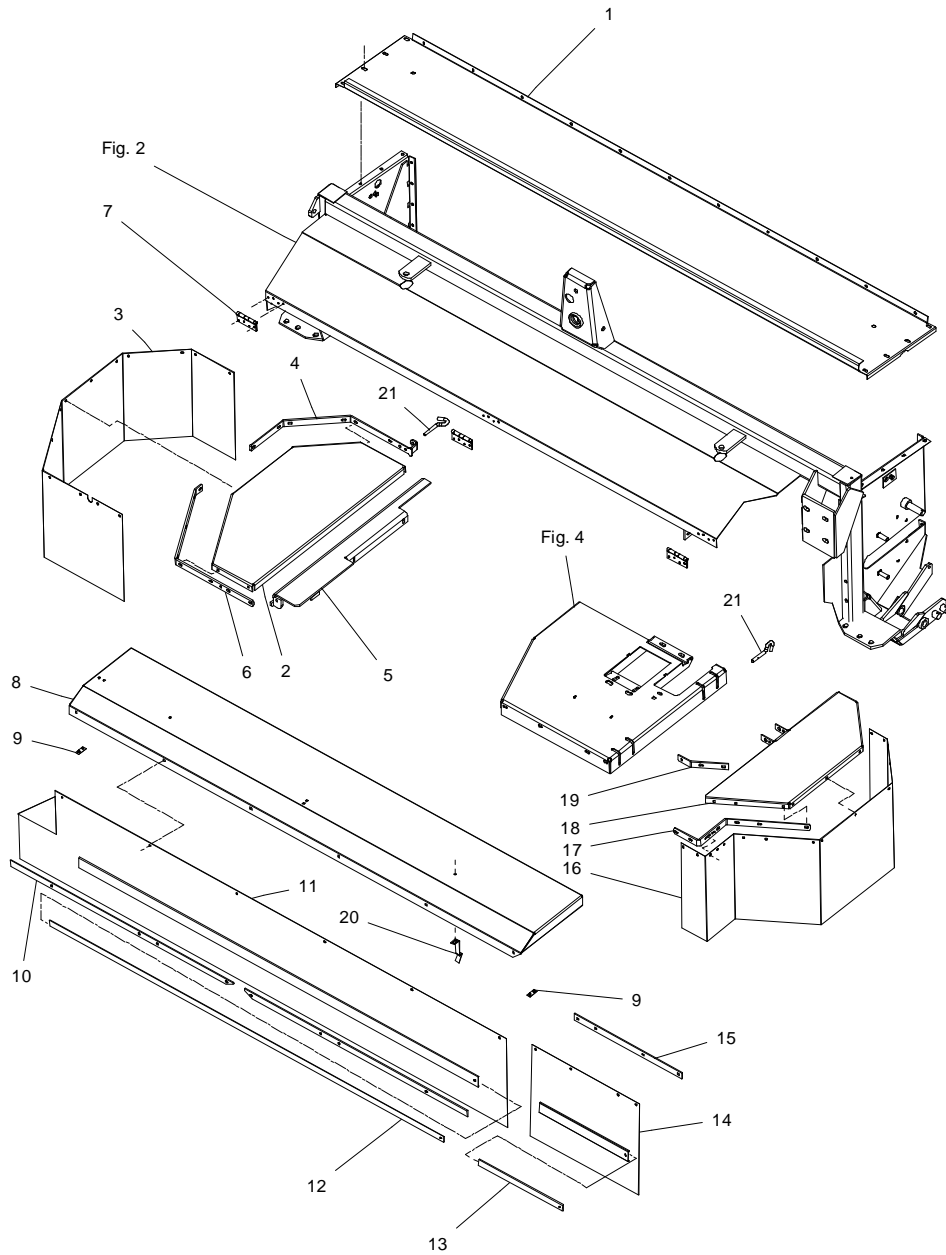

GMS-0020/2 GMS 320 C

FIG. 6.

>=213011647

POS.	VARENUMMER	ANTAL	BENEVNELSE	BEZEICHNUNG	DESIGNATION	HERTIL, DAZU, TO THIS, A CECI	
18.	3210-610X	1	SIDESKERM, VENSTRE SEITENWAND, LINKE		SIDE GUARD, LEFT	1214-3424	1
						1220-3321	1
						1241-2602	8
						1434-0101	2
19.	2210-611X	1	HOLDER HALTER		SUPPORT		
20.	1433-0314	1	LÅSEFJEDER SPERRFEDER		SPRING	1220-2321	1
						1241-1202	1
21.	2086-829X	2	STYRETAP STEUERUNGSSZAPFEN		GUIDE DOWEL	1241-2202	1
						1251-2104	1
						1431-2195	1

Fig. 7

GMS-0020/2 GMS 320 C

FIG. 7.

>=2130111647

HERTIL, DAZU,  
TO THIS, A CECI

POS.	VARENUMMER	ANTAL	BENEVNELSE	BEZEICHNUNG	DESIGNATION
.	1380-0228		KNIVBJELKE 8-SKIVER MÅHBALKEN 8-SCHEIBEN		CUTTER BAR 8-DISC
1.	3085-747X	1	KNIVBJELKE HALVDEL 8-SK SCHNITTBALKEN		CUTTERBAR
3.	1219-0210	34	SKRUE M10-30 SCHRAUBE M10-30	12.9 DELTA B 12.9 DELTA B	SCREW M10-30 12.9 DELTA B
4.	3085-738A	2	LEJEHUS DREV RITZEL LAGERGEHÅUSE		PINION BEARINGHOUSING
5.	3085-705X	6	LEJEHUS LAGERGEHÅUSE		BEARING HOUSING
6.	2085-733X	14	KNIVBJELKE SKRUE SCHNITTBALKEN SCHRAUBE		SCREW FOR CUTTERBAR
7.	2085-729X	98	MØTRIK M10 H=10 MUTTER M10 H=10		NUT M10 H=10
8.	1219-0208	36	KNIVBJELKE SKRUE SCHNITTBALKEN SCHRAUBE		SCREW FOR CUTTERBAR
9.	1219-0227	14	UNBRACOSKRUE M10-20 MK INNENSECHSKANTSCHR M10-20 MK		ALLEN SCREW M10-20 MK
10.	2085-717X	14	TAP ZAPFEN		DOWEL
11.	2085-719X	14	SKIVE 40,3X51,3X3 SCHEIBE 40,3X51,3X3		WASHER 40,3X51,3X3
12.	2085-720X	14	LEJE 6208 N/C3 LAGER 6208 N/C3		BEARING 6208 N/C3
13.	2085-721X	8	SPRINGRING KLEMMRING		SPRINGRING
14.	2085-724X	14	MELLEMHJUL Z45 M3 ZWISCHENRAD Z45 M3		INTERMEDIATE WHEEL Z45 M3
15.	2085-718X	14	SKRUE M20X18 SCHRAUBE M20X18		SCREW M20X18
16.	2085-723X	14	MØTRIK MUTTER		NUT
17.	1315-9671	4	SKIVE 17 X 22 X 1,5 SCHEIBE 17 X 22 X 1,5		WASHER 17 X 22 X 1,5
18.	2085-731X	4	PROP 3/8" VERSCHLUSS 3/8"		PLUG 3/8"
19.	2085-735X	2	SPENDSTIFT M10X12 D1481 SPANNSTIFT M10X12 D1481		ROLL PIN M10X12 D1481
40.	2085-739X	1	FLANGE FLANSCH		FLANGE
41.	2085-706X	1	TANDHJUL Z34 M20 ZAHNRAD Z34 M20		SPROCKET WHEEL Z34 M20
42.	2085-707X	1	FLANGE FLANSCH		FLANGE
43.	2085-709X	1	LÅSEMØTRIK M20X1,5 GEGENMUTTER M20X1,5		LOCK NUT M20X1,5
44.	1434-0108	1	TALLERKENFJEDER 20,0-40-2,5 TELLERFEDER 20,0-40-2,5		DISC SPRING 20,0-40-2,5
45.	2085-710X	1	BØSNING BUCHSE		BUSH
46.	2085-711X	1	OLIETÆTNINGSRING DICHTUNGSRING 8L		SEAL RING OIL

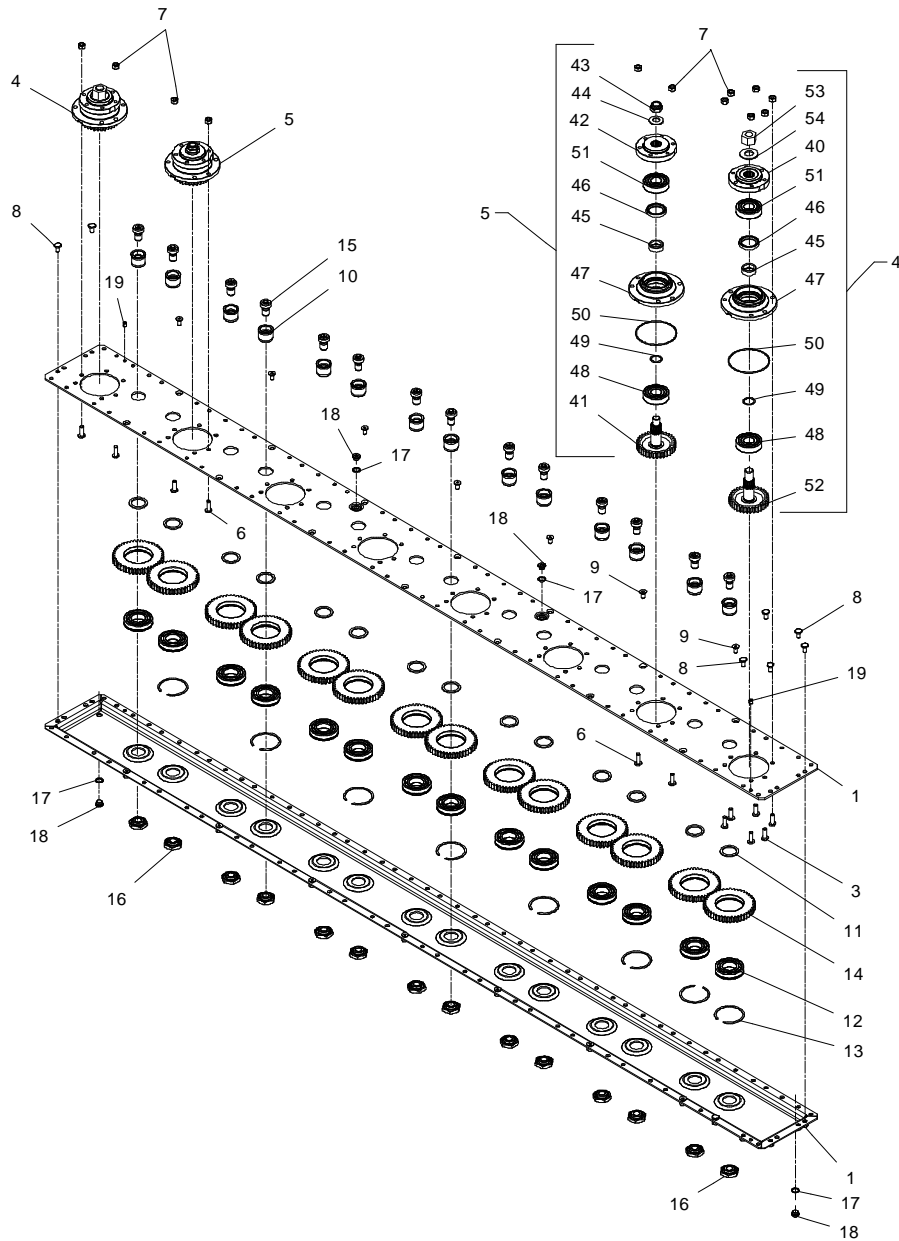

Fig. 7

GMS-0020/2 GMS 320 C

FIG. 7.

>=2130111647

HERTIL, DAZU,  
TO THIS, A CECI

POS.	VARENUMMER	ANTAL	BENEVNELSE	BEZEICHNUNG	DESIGNATION
47.	2085-708X	1	LEJEHUS LAGERGEHAEUS		BEARING HOUSING
48.	2085-712X	1	LEJE 6306C3/Z2 LAGER 6306C3/Z2		BEARING 6306C3/Z2
49.	2085-714X	1	O-RING 3112 O-RING 3112		O-RING 3112
50.	2085-715X	1	O-RING O-RING		O-RING
51.	2085-716X	1	KUGLELEJE 6306 C3 2RS KUGELLAGER 6306 C3 2RS		BALL BEARING 6306 C3 2RS
52.	2085-750X	1	TANDHJUL Z34 M24 ZAHNRAD Z34 M24		SPROCKET WHEEL Z34 M24
53.	2085-751X	1	LÅSEMØTRIK M24X1,5 GEGENMUTTER M24X1,5		LOCK NUT M24X1,5
54.	1434-0111	1	TALLERKENFJEDER 25,4-50-3 TELLERFEDER 25,4-50-3		DISC SPRING 25,4-50-3

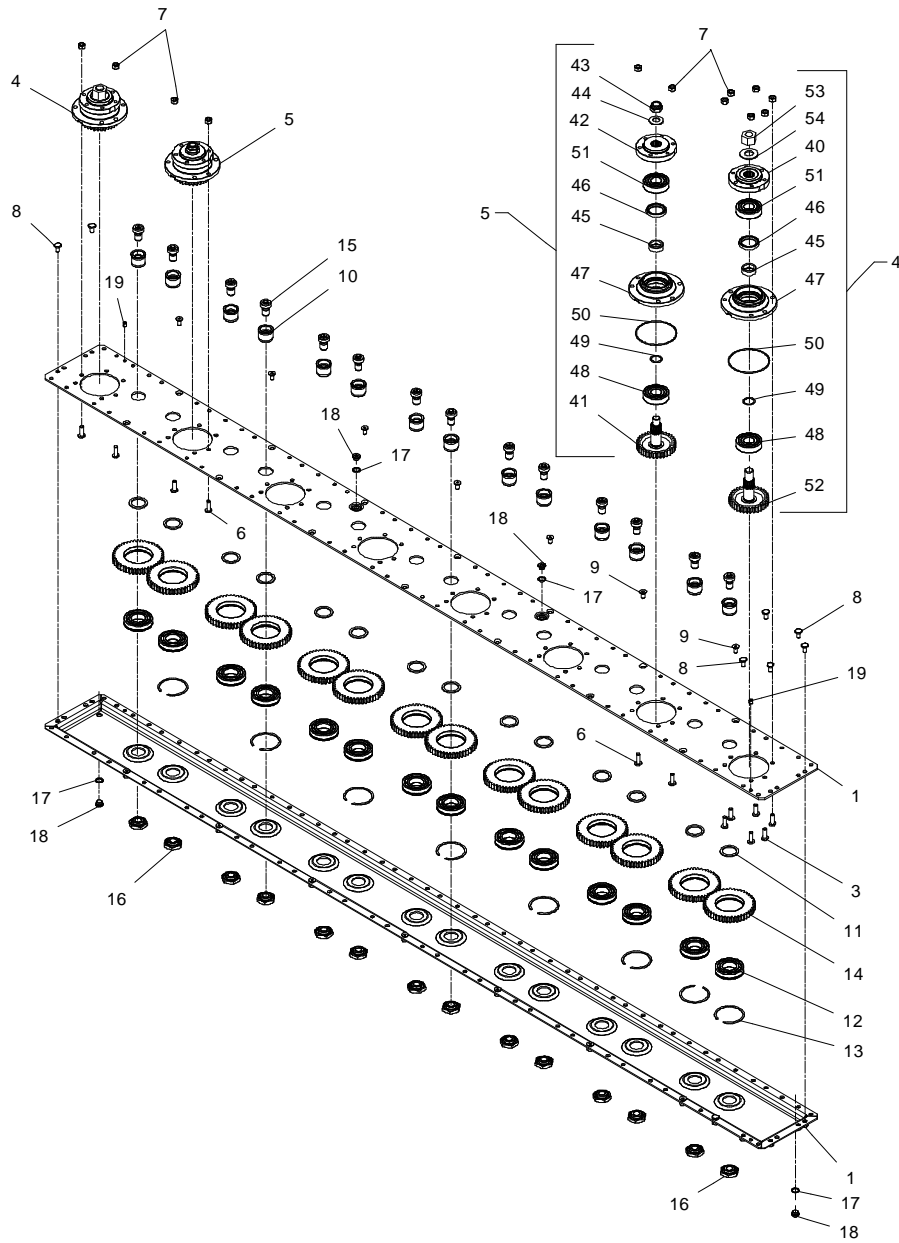

Fig. 8

GMS-0020/2 GMS 320 C

FIG. 8.

>=2130111647

HERTIL, DAZU,  
TO THIS, A CECI

POS.	VARENUMMER	ANTAL	BENEVNELSE	BEZEICHNUNG	DESIGNATION		
1.	2085-704X	8	MELLEMLEG DICHTUNG		DISTANCE PIECE		
2.	3214-724X	7	SKIVE SCHEIBE		DISC		
3.	2085-703X	6	TOP OBERTEIL		TOP	1213-3224 1241-2402	6 6
4.	1380-0013	16	KNIV MÆHKLINGE		KNIFE		
5.	1219-0809	16	KNIVBOLT M12 KV. 10.9 MESSERBOLZEN M12 Q. 10.9		KNIFE BOLT M12 Q. 10.9	1220-4323	1
6.	3214-725X	1	HDS-SKIVE M. TROMLE HDS-SCHEIBE M. WALZE		HDS-DISC W. BARREL	1213-3224 1241-2402	6 6
7.	2089-180X	1	TÆTNING DICHTUNG		SEAL	1213-3222 1220-3922	4 4
8.	1350-0145	1	BJÆLKEDREV L= 370 MM BALKEN L= 370 MM		CUTTERBAR L= 370 MM	1219-0266	6
9.	3214-726X	1	TROMLE TROMMEL		DRUM	1213-3222 1220-3321	4 4
10.	2225-397X	1	TÆTNING DICHTUNG		SEAL	1213-3224 1220-3323 1241-2402	4 4 4
11.	3210-436X	1	KONTROLLERE KONTROLLEHRE		CONTROL GAUGE		

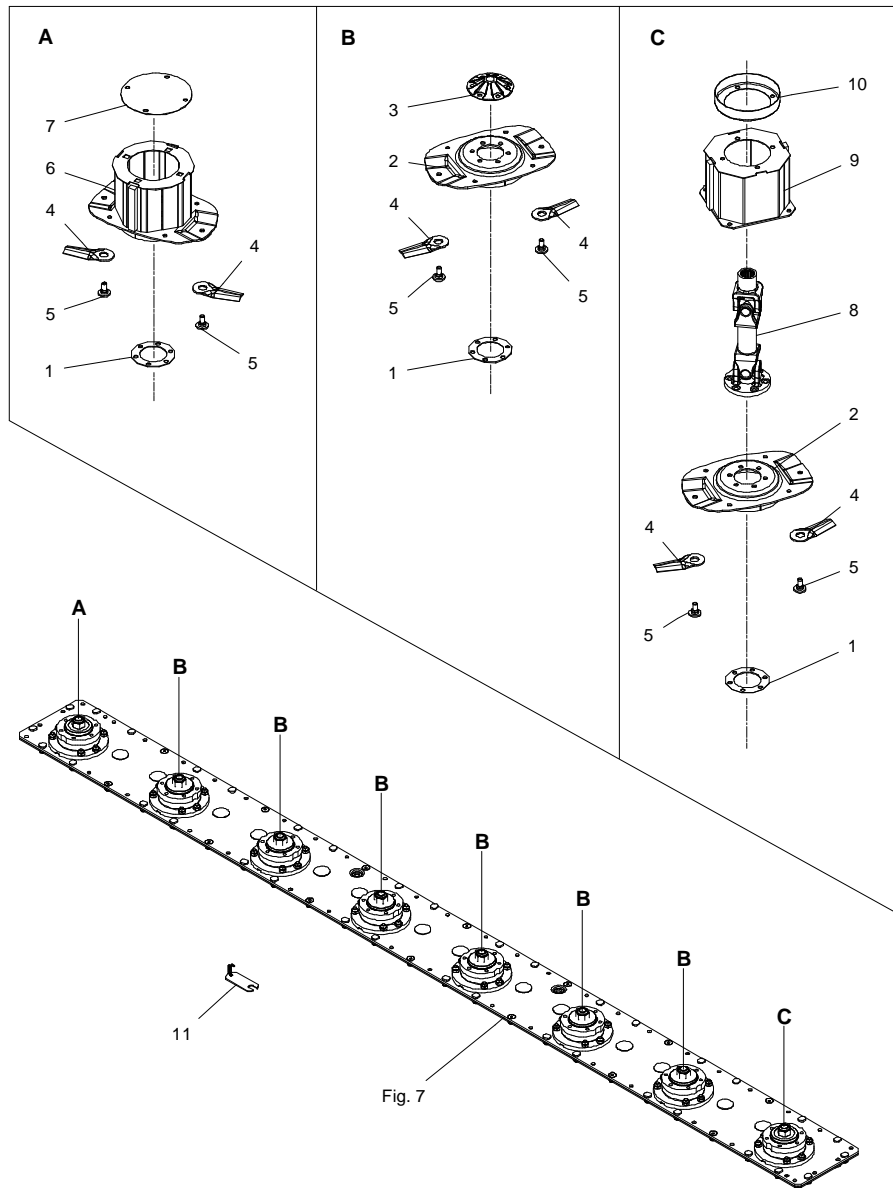

Fig. 9

GMS-0020/2 GMS 320 C

FIG. 9.

>=2130111647

HERTIL, DAZU,  
TO THIS, A CECI

POS.	VARENUMMER	ANTAL	BENEVNELSE	BEZEICHNUNG	DESIGNATION		
1.	3214-702X	1	BJÆLKEOPHÆNG BALKEN AUFHÄNGUNG		BAR SUSPENSION	1219-0210	25
						1220-3323	25
2.	2088-566X	2	MELLEMLÆG DICHTUNG		DISTANCE PIECE		
3.	3088-554X	7	MODSKÆR GEGENSCHNEIDE		SHEAR BAR		
4.	3214-623X	8	STENBESKYTTER STEINSCHUTZ		STONE PROTECTOR	1219-0210	2
						1220-3323	2
5.	2081-039X	8	TAP SPLINTBOLZEN		COTTER BOLT	1252-3102	1
						1433-0298	1

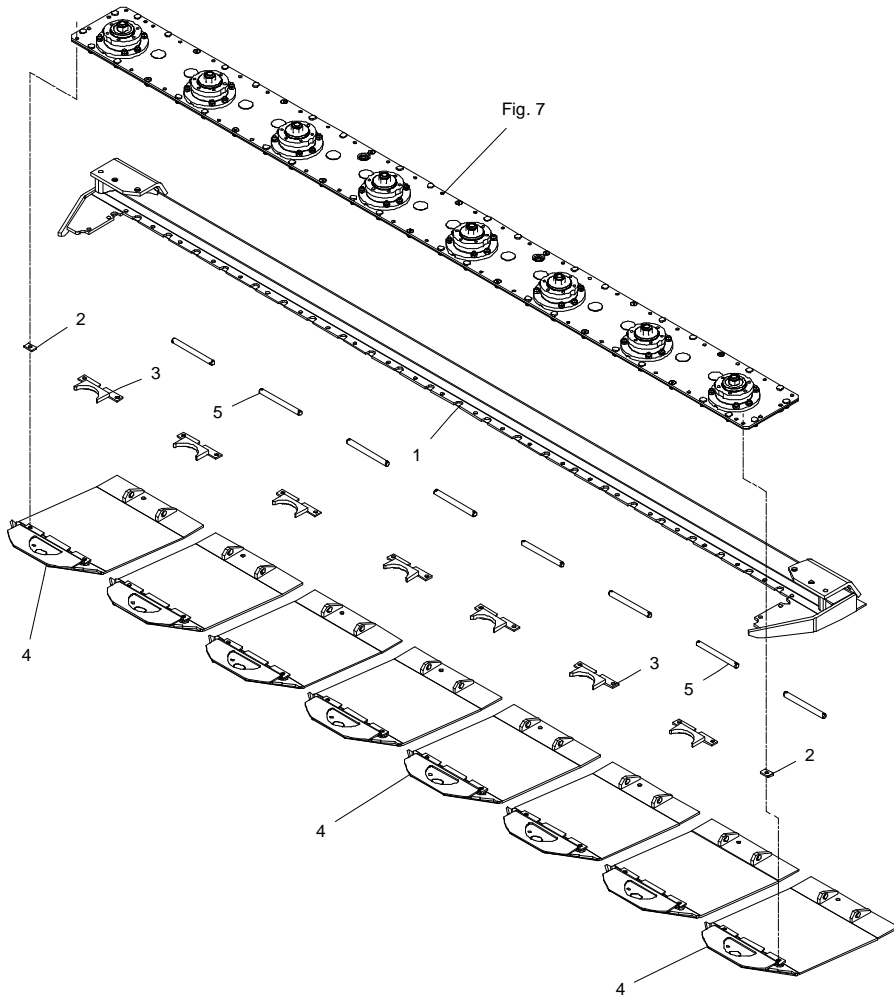
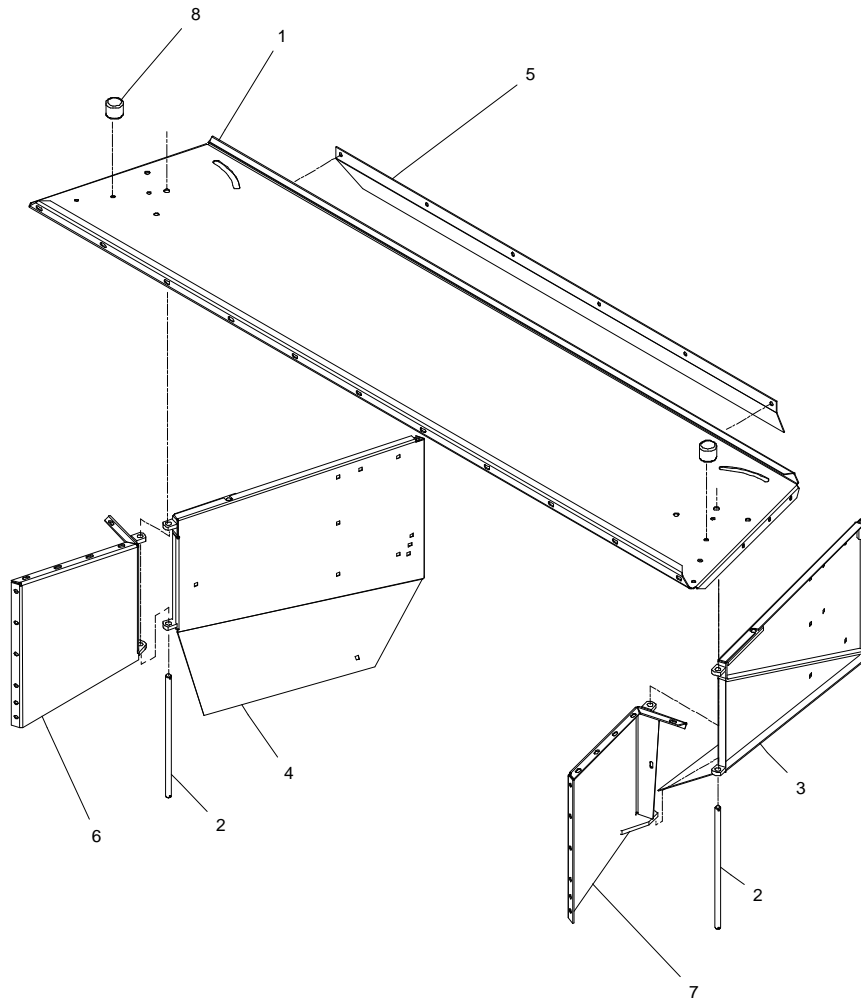



Fig. 10



GMS-0020/2 GMS 320 C

FIG. 10.

>=2130111647

POS.	VARENUMMER	ANTAL	BENØVNELSE	BEZEICHNUNG	DESIGNATION	HERTIL, DAZU, TO THIS, A CECI	
1.	2228-491X	1	OVERPLADE		UPPER BAR	1213-3224	19
			OBERPLATTE			1220-3321	19
						1241-2502	38
2.	2226-550X	2	TAP		SHAFT	1241-4403	1
			WELLE			1252-4201	1
3.	3226-553X	1	SKÅRPLADE, VENSTRE		SWATH PLATE, LEFT	1213-5224	1
			SCHWADPLATTE, LINKE			1241-4601	1
4.	3226-554X	1	SKÅRPLADE, HØJRE		SWATH PLATE, RIGHT	1213-5224	1
			SCHWADPLATTE, RECHTE			1241-4601	1
5.	2228-492X	1	PLADE		PLATE	1213-3224	6
			PLATTE			1220-3321	6
						1241-2502	12
6.	3228-372X	1	SIDEPLADE, HØJRE		SIDEBOARD, RIGHT	1213-3224	5
			SEITENWAND, RECHTE			1220-3321	5
						1241-2502	10
7.	3226-559X	1	SIDEPLADE, VENSTRE		SIDE PLATE, LEFT	1213-3224	5
			SEITENPLATTE, LINKE			1220-3321	5
						1241-2502	10
8.	1393-0110	2	GUMIBUFFE		RUBBER BUFFER	1214-3226	2
			GUMIBUFFER			1241-2502	2

Fig. 30

GMS-0020/2 GMS 320 C

FIG. 30.

>=2130111647

HERTIL, DAZU,  
TO THIS, A CECI

POS.	VARENUMMER	ANTAL	BENEVNELSE	BEZEICHNUNG	DESIGNATION
.	3227-872X		GEAR GETRIEBE		GEAR
1.	1315-9848	2	HUS GEHEAUSE		GEAR CASE
2.	1315-9600	1	KEGLEHJUL KEGELRAD		CONICAL WHEEL
4.	1315-9599	1	KEGLEHJUL KEGELRAD		CONICAL WHEEL
5.	1315-9845	2	AKSEL WELLE		SHAFT
6.	1315-9598	2	KEGLEHJUL KEGELRAD		CONICAL WHEEL
7.	1315-9843	1	AKSEL WELLE		SHAFT
8.	1315-9842	1	FLANGE, INDVENDIG FLANSH, INNEN		FLANGE, INNER
9.	1315-9841	1	FLANGE, UDVENDIG FLANSH, AUSSER		FLANGE, OUTER
10.	1315-9840	1	MØTRIK MUTTER		NUT
11.	1315-9839	1	HUS GEHEAUSE		GEAR CASE
12.	1315-9838	5	AFSTANDSRING DISTANZRING		SPACER
13.	1315-9837	5	AFSTANDSRING, SET DISTANZRING, SATZ		SPACER, SET
14.	1315-9836	2	UDLUFTNINGSVENTIL ENTLUFTUNGSVENTIL		AIR SCAPE VALVE
15.	1315-9835	4	PROP VERSCHLUSS		PLUG
16.	1315-9834	2	DEKSEL BLENDE		COVER
17.	1315-9833	2	RING RING		RING
18.	1315-9832	4	RULLELEJE KEGELROLLENLAGER		ROLLER BEARING
19.	1331-9932	2	RULLELEJE ROLLENLAGER		ROLLER BEARING
20.	1315-9830	1	RULLELEJE KEGELROLLENLAGER		ROLLER BEARING
21.	1315-9829	1	RULLELEJE KEGELROLLENLAGER		ROLLER BEARING
23.	1332-4801	2	OLJETÆTNINGSRING M 40-80-10 DICHTUNGSRING M 40-80-10		OIL SEAL M 40-80-10
24.	1332-4802	1	OLJETÆTNINGSRING 40-80-7 DICHTUNGSRING 40-80-7		OIL SEAL 40-80-7
25.	1315-9826	1	TÆTNINGSRING DICHTRING		SEALING RING
26.	1315-9825	1	TÆTNINGSRING DICHTRING		SEALING RING
27.	1315-9824	1	LÅSERING SICHERUNGSRING		CIRCLIP

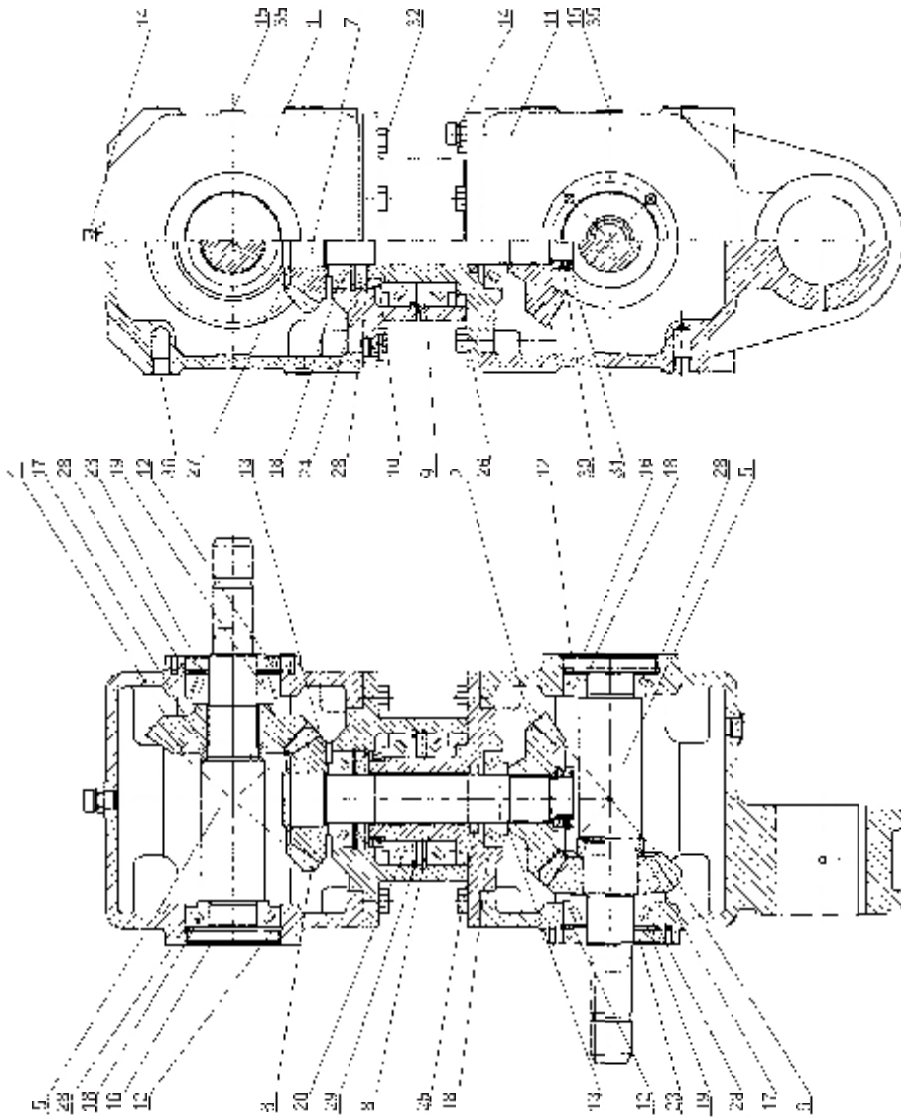

Fig. 30

GMS-0020/2 GMS 320 C

FIG. 30.

>=2130111647

HERTIL, DAZU,  
TO THIS, A CECI

POS.	VARENUMMER	ANTAL	BENØVNELSE	BEZEICHNUNG	DESIGNATION
28.	1255-7102	6	LÅSERING 80 MM INDVENDIG SICHERINGSRING 80 MM INNEN		SNAP RING 80 MM INNER
29.	1315-9822	1	LÅSERING SICHERINGSRING		CIRCLIP
30.	1315-9821	1	LÅSEBLIK SICHERINGSBLECH		STRIKER PLATE
31.	1315-9820	2	MØTRIK MUTTER		NUT
32.	1315-9819	16	SEKSKANTSKRUE SECHSKANTSCHRAUBE		HEXAGON HEADED SCREW
35.	1315-9878	4	SKIVE SCHEIBE		SHIM
36.	1315-9804	16	PROP VERSCHLUSS		PLUG

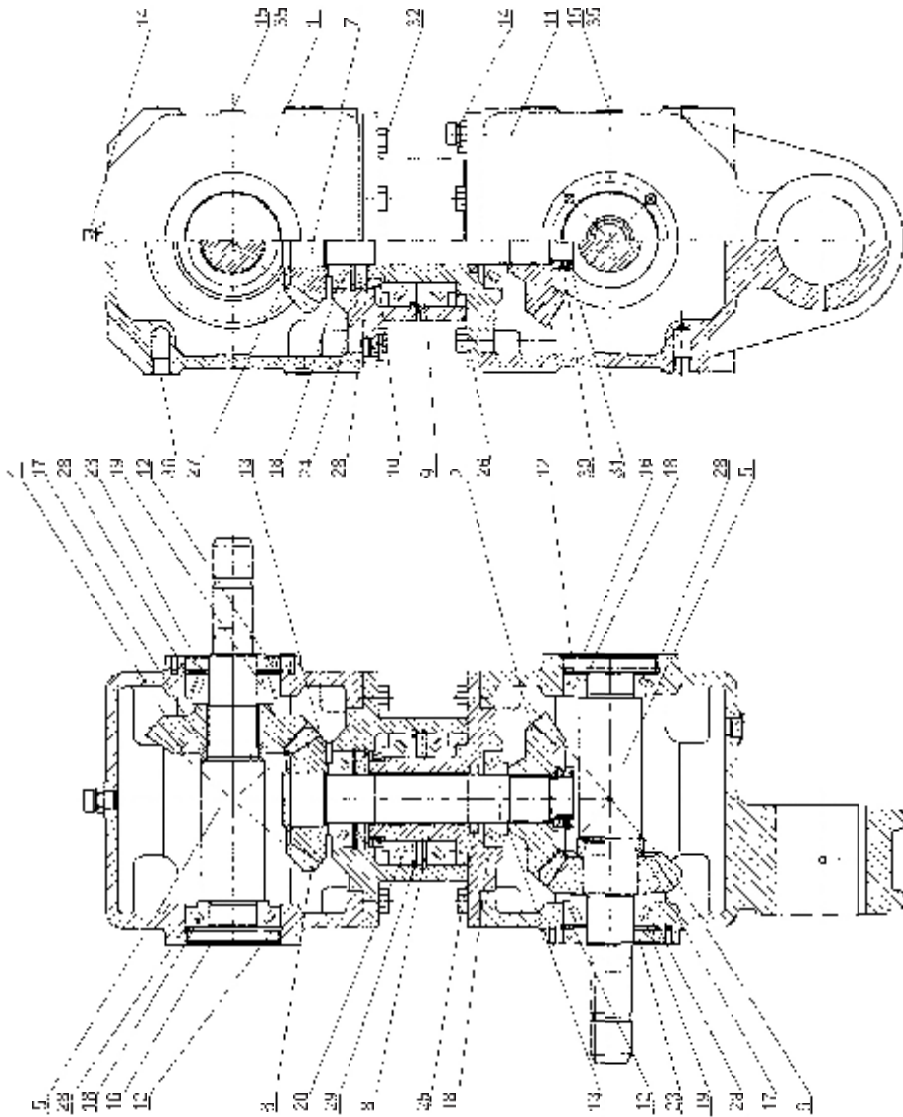
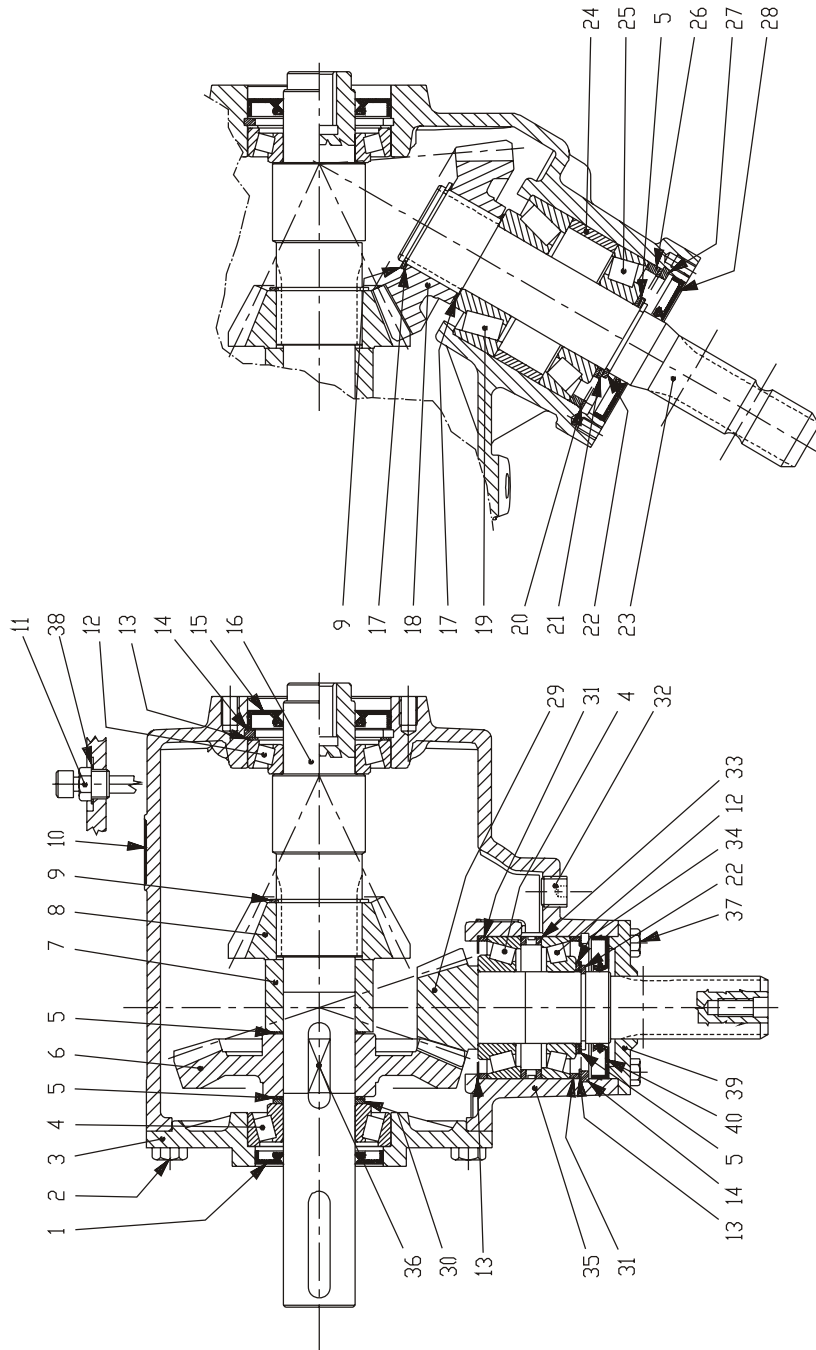

Fig. 31



GMS-0020/2 GMS 320 C

FIG. 31.

>=2130111647

HERTIL, DAZU,  
TO THIS, A CECI

POS.	VARENUMMER	ANTAL	BENEVNELSE	BEZEICHNUNG	DESIGNATION
.	3210-453X		GEAR GETRIEBE		GEAR
1.	1315-9907	1	TETNING DICHTUNG		SEAL
2.	1213-3224	8	STÅLSETSKRUE M10-25 ST. SETSCHRAUBE M10-25		STEEL SET SCREW M10-25
3.	1315-9908	1	DEKSEL DECKEL		COVER
4.	1315-9909	2	LEJE LAGER		BEARING
5.	1315-9109	4	AFSTANDSRING, SET DISTANZRING, SATZ		DISTANCE RING, SET
6.	1315-9339	1	GEAR GEAR		GEAR
7.	1315-9910	1	AFSTANDSSKIVE AUSGLEICHSCHIEBE		SPACER
8.	1315-9911	1	SPIDSHJUL KEGELRAD		PINION WHEEL
9.	1315-9912	2	LÅSERING SCHLISSRING		SNAP RING
10.	1315-9272	1	PLADE PLATTE		PLATE
11.	1315-9913	1	PROP VERSCHLUSS		PLUG
12.	1331-9994	2	RULLELEJE KONISK 30208A ROLLENLAGER 30208A		ROLLER BEARING 30208A
13.	1315-9226	3	MELLEMLEG ZWISCHENLAGE		SHIM
14.	1315-9349	2	LÅSERING 80 MM INDVENDIG SICHERUNGSRING 80 MM INNEN		SNAP RING 80 MM INNER
15.	1315-9918	1	TETNING DICHTUNG		SEAL
16.	1315-9919	1	AKSEL WELLE		SHAFT
17.	1315-9920	2	SKIVE SCHEIBE		SHIM
18.	1315-9921	1	KRONHJUL KRONRAD		CROWN WHEEL
19.	1315-9922	1	LEJE LAGER		BEARING
20.	1315-9923	1	SKIVE SCHEIBE		SHIM
21.	1315-9924	1	SKIVE SCHEIBE		SHIM
22.	1255-4201	2	LÅSERING 40 MM UDVENDIG SICHERUNGSRING 40 MM AUSSEN		SNAP RING 40 MM OUTER
23.	1315-9925	1	AKSEL WELLE		SHAFT
24.	1315-9926	1	AFSTANDSSKIVE AUSGLEICHSCHIEBE		SPACER
25.	1315-9110	1	RULLELEJE ROLLENLAGER		ROLLER BEARING

Fig. 31

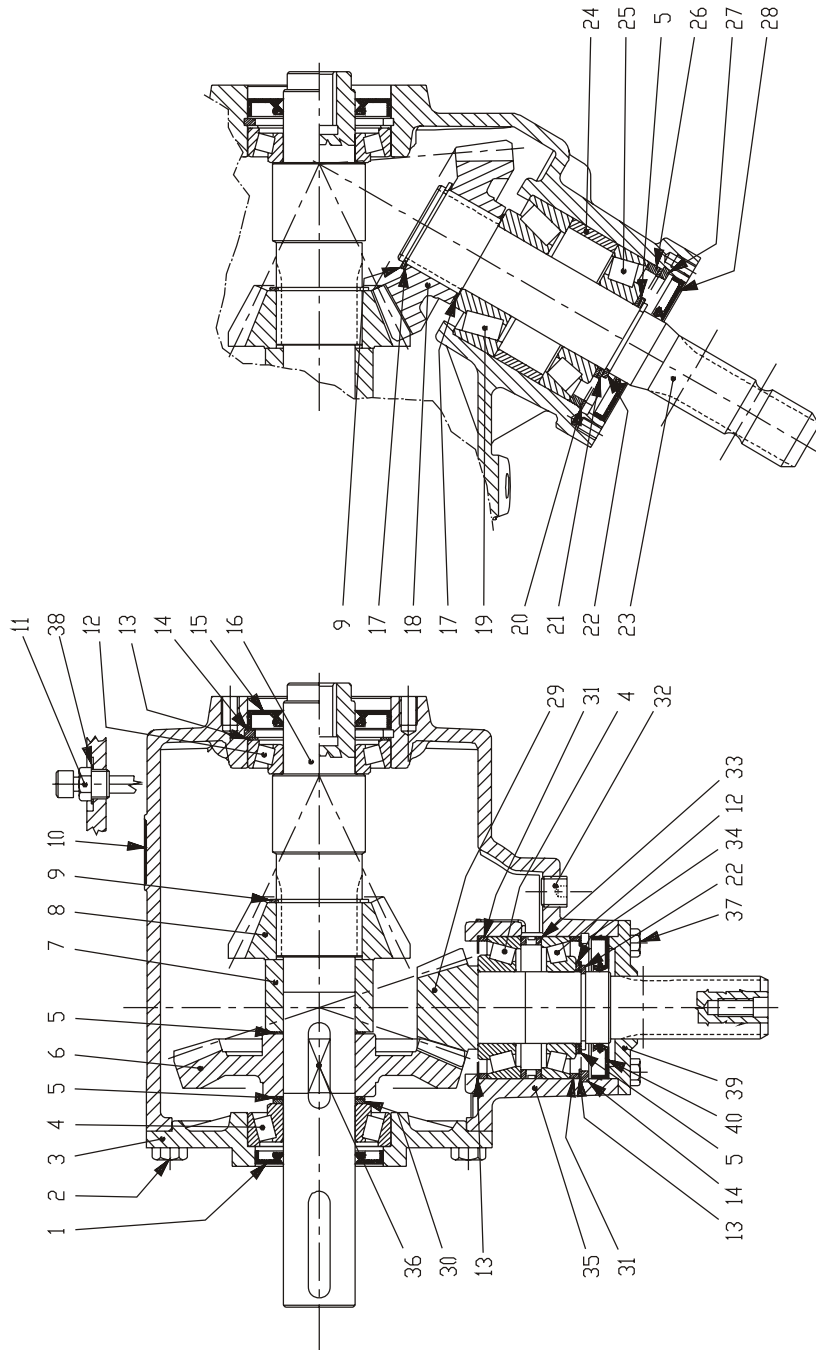

GMS-0020/2 GMS 320 C

FIG. 31.

>=2130111647

HERTIL, DAZU,  
TO THIS, A CECI

POS.	VARENUMMER	ANTAL	BENEVNELSE	BEZEICHNUNG	DESIGNATION
26.	1315-9927	1	AFSTANDSSKIVE AUSGLEICHSCHEIBE		SPACER
27.	1315-9928	1	LÅSERING SCHLIESSRING		SNAP RING
28.	1315-9929	1	OLIETÆTNINGSRING OELDICHTUNGSRING		OIL TIGHTENING RING
29.	1315-9930	1	AKSEL WELLE		SHAFT
30.	1315-9931	2	SKIVE SCHEIBE		SHIM
31.	1315-9932	2	AFSTANDSSKIVE AUSGLEICHSCHEIBE		SPACER
32.	1315-9245	1	PROP ROHRVERSCHLUSS		PLUG
33.	1315-9933	1	AFSTANDSSKIVE AUSGLEICHSCHEIBE		SPACER
34.	1315-9385	2	SKIVESÆT SCHEIBENSATZ		SET AF WASHERS
35.	1315-9934	1	GEARHUS GETRIEBEKASTEN		GEAR BOX
36.	1338-0102	1	PASFEDER 12-8-28 FEDERKEIL 12-8-28		FLAT KEY 12-8-28
37.	1213-2222	4	STÅLSETSBRUE M8-20 ST. SETSCHRAUBE M8-20		STEEL SET SCREW M8-20
38.	1315-9935	1	KOBBERPAKNING KUPFERDICHTUNG		COPPER WASHER
39.	1315-9936	1	DEKSEL DECKEL		COVER
40.	1332-4801	1	OLIETÆTNINGSRING M 40-80-10 DICHTUNGSRING M 40-80-10		OIL SEAL M 40-80-10

Fig. 40

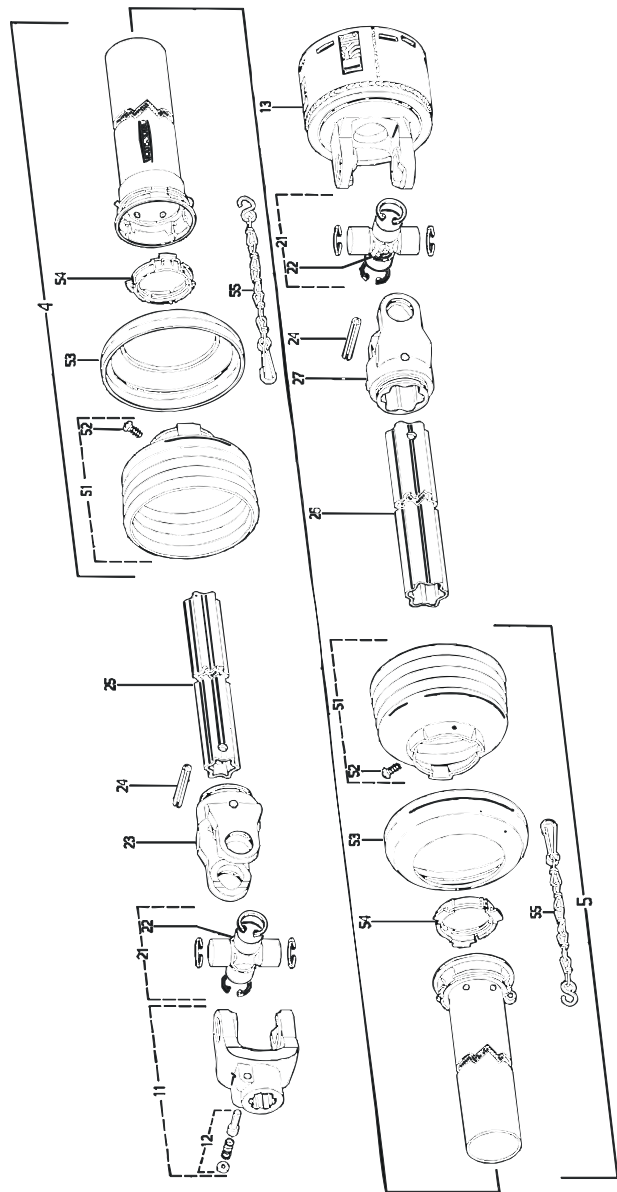

GMS-0020/2 GMS 320 C

FIG. 40.

>=2130111647

HERTIL, DAZU,  
TO THIS, A CECI

POS.	VARENUMMER	ANTAL	BENEVNELSE	BEZEICHNUNG	DESIGNATION
.	1340-1406		KO-AKSEL W2400 / 1000 RPM GELENKWELLE W2400 / 1000 RPM		PTO SHAFT W2400 / 1000 RPM
4.	1501-0010	1	BESKYTTELSESRØR UDV. 1000 MM SCHUTZROHR AUSSEN, 1000 MM		PROTECTION TUBE, OUTER 1000 MM
5.	1501-0009	1	BESKYTTELSESRØR, INDV. 1000 MM SCHUTZROHR INNEN, 1000 MM		PROTECTION TUBE INNER, 1000 MM
11.	1340-9028	1	KOBLINGSGAFFEL 1 3/8" (6) AUFSTECKGABEL 1 3/8" (6)		CLUTCH FORK 1 3/8" (6)
12.	1341-9523	1	LÅSESTIFT SPERRSTIFT		LOCKING PIN
21.	1340-9153	2	KRYDS KREUZGARNITUR		CENTRE CROSS
22.	1341-9188	2	SMØRENIPPEL C 8 SCHMIERNIPPEL C 8		GREASE NIPPLE C 8
23.	1340-9073	1	RILLEGAFFEL RILLENGABEL		GROOVE FORK
24.	1251-9007	2	SPENDESTIFT 10-80 SPANNSTIFT 10-80		SPECIAL PIN 10-80
25.	1501-0113	1	PROFILRØR S4LH 1000 MM PROFILROHR GR.S4LH 1000 MM		PROFILE TUBE SIZE S4LH 1000 MM
26.	1501-0117	1	PROFILRØR, 1000 MM PROFILROHR, 1000 MM		PROFIL TUBE, 1000 MM
27.	1340-9082	1	RILLEGAFFEL RILLENGABEL		GROOVE FORK
51.	1501-0022	2	PLASTIKSKERM Ø165 SCHUTZTRICHTER Ø165		PLASTIC GUARD Ø165
52.	1341-9411	2	SKRUE SCHRAUBE		SCREW
53.	1341-9630	2	FORSTERKNINGSRING STÜTZRING		SUPPORT RING
54.	1341-9618	2	GLIDRING GLEITRING		BEARING RING
55.	1341-9641	2	HOLDEKED HALTEKETTE		CHAIN
99.	1340-9096	T 1	GAFFEL (8) RUSLAND GABEL (8) RUSSLAND		FORK (8) RUSSIA

Fig. 41

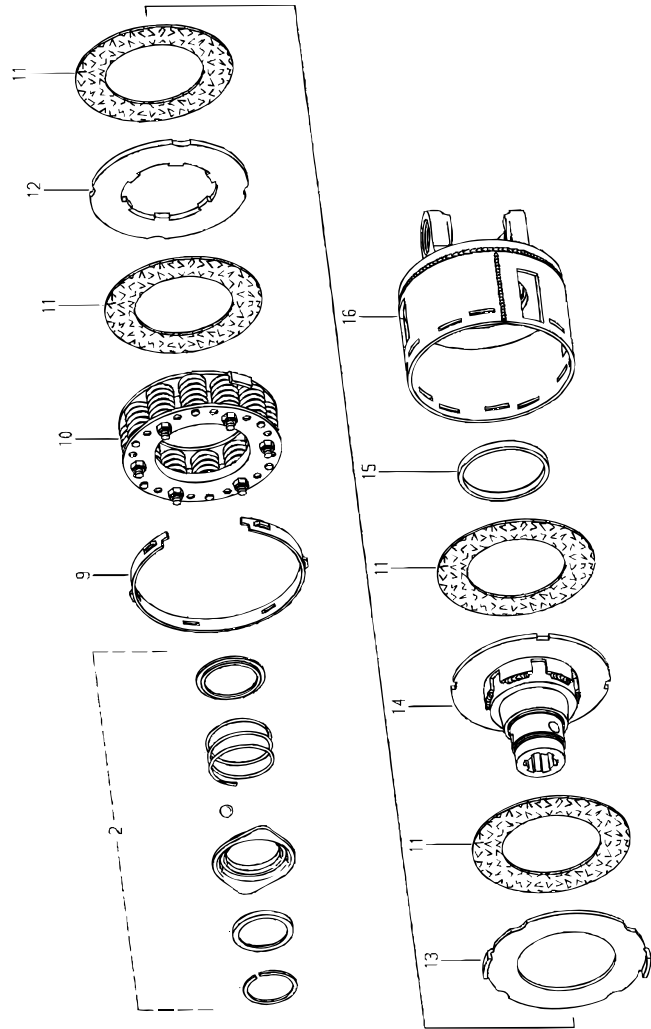

GMS-0020/2 GMS 320 C

FIG. 41.

>=1230111647

HERTIL, DAZU,  
TO THIS, A CECI

POS.	VARENUMMER	ANTAL	BENEVNELSE	BEZEICHNUNG	DESIGNATION		
.	1340-9118		FRIKTIONSKOBLING K96/4 REIBKUPPLUNG K96/4		FRICITION CLUTCH K96/4		
2.	1341-9524	1	SKYDELÅS ZIEHVERSCHLUS		QUICK-DISCONNECT LOCK	1339-0112	3
9.	1341-9643	1	INDSTILLINGSRING EINSTELLRING		SETTING RING		
10.	1340-9200	1	FJEDERSÆT KPL. FEDER KPL.		SPRING CPL.		
11.	1341-9569	4	FRIKTIONSBELEGNING REIBSCHEIBE		FRICITION DISK		
12.	1341-9561	1	MEDBRINGSKIVE MITNEHMERSCHEIBE		CARRIER PLATE		
13.	1341-9562	1	MEDBRINGERSKIVE MITNEHMERSCHEIBE		CARRIER PLATE		
14.	1341-9162	1	FLANGENAV FLANSCHNABE		FLANGE HUB		
15.	1341-9644	1	LØBERING LAUFRING		SUPPORTING ROLLER		
16.	1340-9056	1	FLANGEGAFFEL MED HUS FLANSCHGABEL MIT GEHÄUSE		FLANGE FORK WITH HOUSING		



Fig. 42

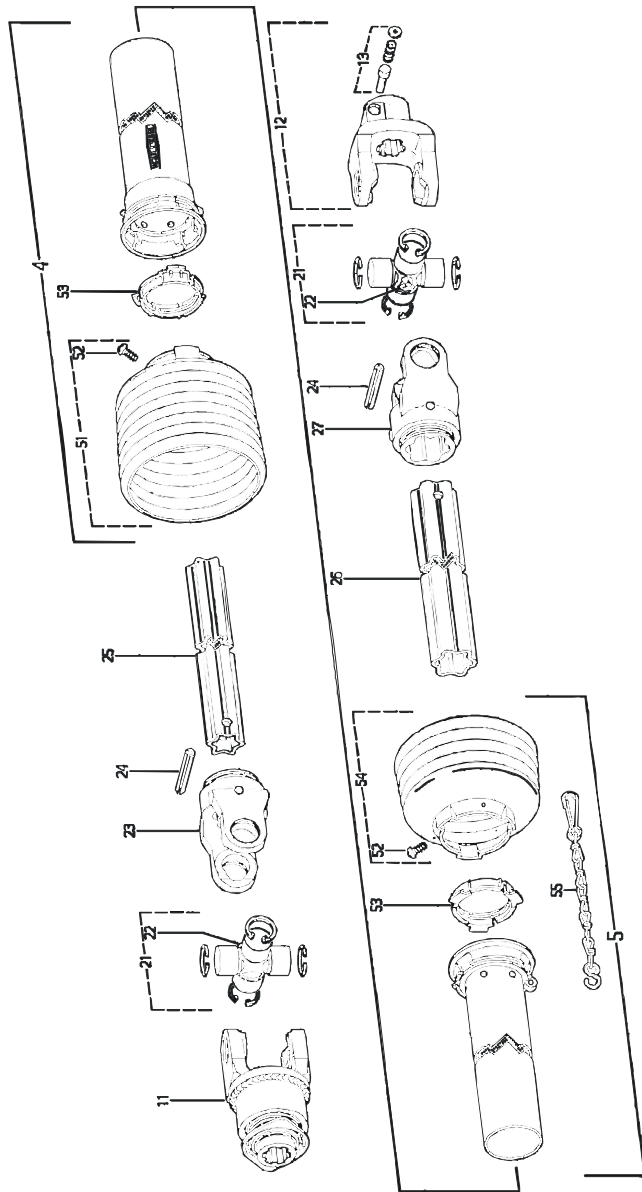

GMS-0020/2 GMS 320 C

FIG. 42.

>=1230111647

HERTIL, DAZU,  
TO THIS, A CECI

POS.	VARENUMMER	ANTAL	BENEVNELSE	BEZEICHNUNG	DESIGNATION
.	1340-1408		KO-AKSEL W2400 / 1000 RPM GELENKWELLE W2400/ 1000 RPM		PTO SHAFT W2400 / 1000 RPM
4.	1501-0010	1	BESKYTTELSESRØR UDV. 1000 MM SCHUTZROHR AUSSEN, 1000 MM		PROTECTION TUBE, OUTER 1000 MM
5.	1501-0009	1	BESKYTTELSESRØR, INDV. 1000 MM SCHUTZROHR INNEN, 1000 MM		PROTECTION TUBE INNER, 1000 MM
11.	1340-9135	1	STIFTFRILØB F5/1R-W2400 STIFTFREILAUF F5/1R-W2400		FREE WHEEL F5/1R-W2400
12.	1340-9028	1	KOBLINGSGAFFEL 1 3/8" (6) AUFSTECKGABEL 1 3/8" (6)		CLUTCH FORK 1 3/8" (6)
13.	1341-9523	1	LÅSESTIFT SPERRSTIFT		LOCKING PIN
21.	1340-9153	2	KRYDS KREUZGARNITUR		CENTRE CROSS
22.	1341-9188	2	SMØRENIPPEL C 8 SCHMIERNIPPEL C 8		GREASE NIPPLE C 8
23.	1340-9073	1	RILLEGAFFEL RILLEGABEL		GROOVE FORK
24.	1251-9007	2	SPENDESTIFT 10-80 SPANNSTIFT 10-80		SPECIAL PIN 10-80
25.	1501-0113	1	PROFILRØR S4LH 1000 MM PROFILROHR GR.S4LH 1000 MM		PROFILE TUBE SIZE S4LH 1000 MM
26.	1501-0117	1	PROFILRØR, 1000 MM PROFILROHR, 1000 MM		PROFIL TUBE, 1000 MM
27.	1340-9082	1	RILLEGAFFEL RILLEGABEL		GROOVE FORK
51.	1501-0022	1	PLASTIKSKERM Ø165 SCHUTZTRICHTER Ø165		PLASTIC GUARD Ø165
52.	1341-9411	2	SKRUE SCHRAUBE		SCREW
53.	1341-9618	2	GLIDERING GLEITRING		BEARING RING
54.	1501-0022	1	PLASTIKSKERM Ø165 SCHUTZTRICHTER Ø165		PLASTIC GUARD Ø165
55.	1341-9641	1	HOLDEKED HALTEKETTE		CHAIN

Fig. 43

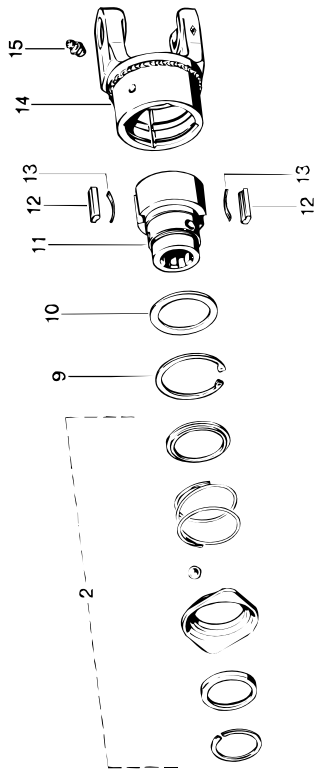

GMS-0020/2 GMS 320 C

FIG. 43.

>=1230111647

HERTIL, DAZU,  
TO THIS, A CECI

POS.	VARENUMMER	ANTAL	BENÆVNELSE	BEZEICHNUNG	DESIGNATION		
.	1340-9135		STIFTFRILØB F5/1R-W2400 STIFTFREILAUF F5/1R-W2400		FREE WHEEL F5/1R-W2400		
2.	1341-9524	1	SKYDELÅS ZIEHVERSCHLUS		QUICK-DISCONNECT LOCK	1339-0112	3
9.	1255-6101	1	LÅSERING 72 MM INDVENDIG SICHERUNGSRING 72 MM INNEN		SNAP RING 72 MM INNER		
10.	1341-9436	1	STØTTESKIVE STÜTZSCHEIBE		SUPPORT WASHER		
11.	1341-9160	1	NAV NABE		HUB		
12.	1341-9733	2	PROFILKILE PROFILKEILE		PROFILE KEY		
13.	1341-9587	2	BLADFJEDER BLATTFEDER		LEAF SPRING		
14.	1340-9055	1	KOBLINGSHUS KUPPLUNGSGEHÄUSE		COUPLING HOUSING		
15.	1341-9189	1	SMØRENIPPEL LIGE M6 SCHMIERNIPPEL M6		GREASE NIPPLE M6		

Fig. 50

GMS-0020/2 GMS 320 C

FIG. 50.

>=1230111647

HERTIL, DAZU,  
TO THIS, A CECI

POS.	VARENUMMER	ANTAL	BENEVNELSE	BEZEICHNUNG	DESIGNATION
.	1324-8313		HJULNAV NABE		WHEEL HUB
3.	1323-9637	1	LEJE LAGER		BEARING
4.	1331-9907	1	KONISK RULLELEJE 30209 KON. ROLLENLAGER 30209		TAPER ROLLER BEARING 30209
5.	1323-9638	1	TÆTNINGSRING DICHTUNGSRING		TIGHTENING RING
6.	1323-9639	1	KRONEMØTRIK KRONENMUTTER		CARSTELLATED NUT
7.	1323-9640	1	SPLIT SPLINT		COTTER PIN
8.	1323-9644	1	KAPPE KAPPE		CAP
9.	1323-9641	6	BOLT BOLTZEN		BOLT
10.	1323-9556	6	MØTRIK M18-1,5 MUTTER M18-1,5		NUT M18-1,5

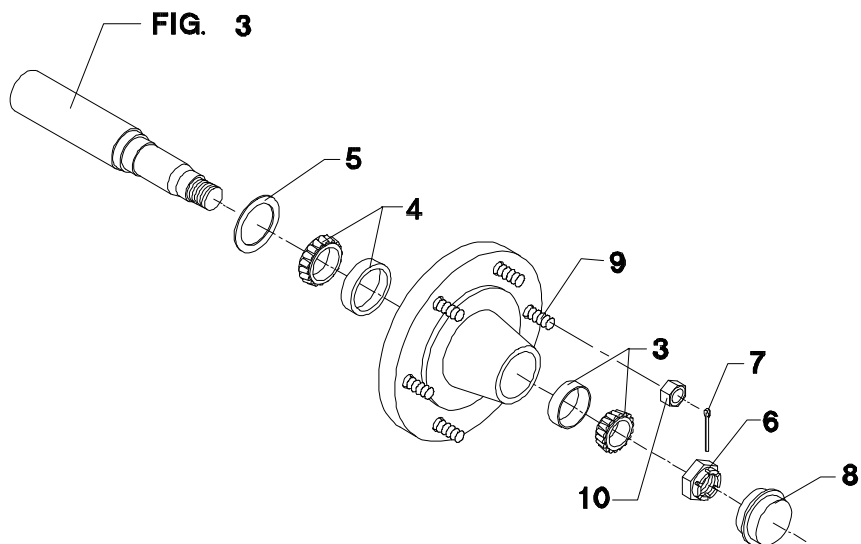

Fig. 80

TILBEHØR - ZUBEHÖR - ACCESSORIES

GMS-0020/2 GMS 320 C

FIG. 80.  
TILBEHØR, ZUBEHÖR, ACCESSORIES

>=1230111647

HERTIL, DAZU,  
TO THIS, A CECI

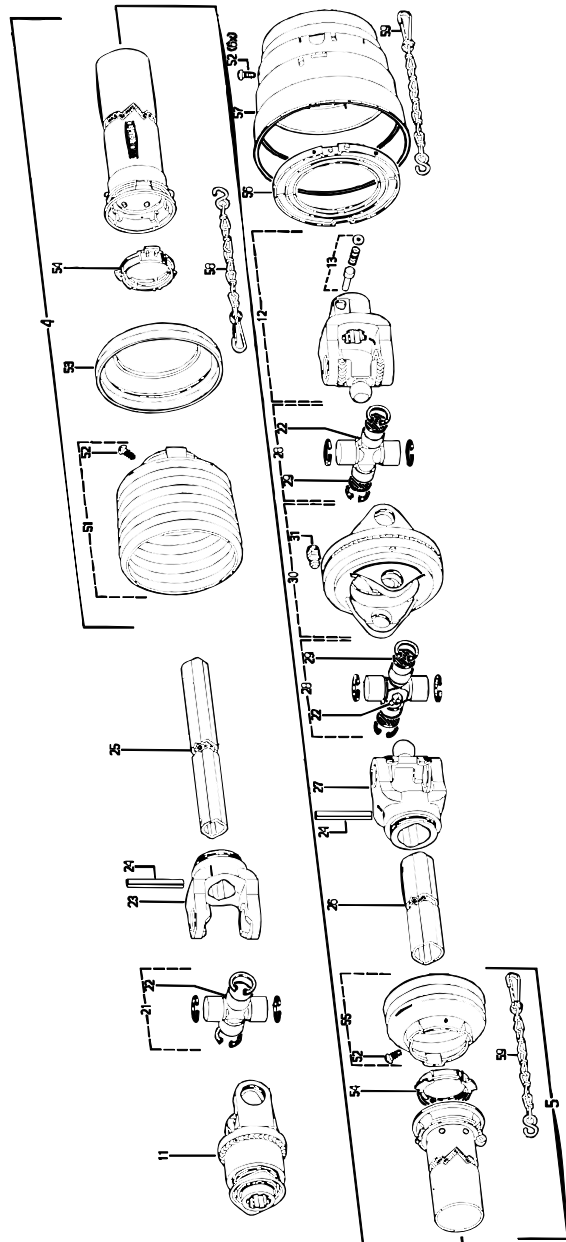

POS.	VARENUMMER	ANTAL	BENEVNELSE	BEZEICHNUNG	DESIGNATION
.	1340-5429		KRAFTOVERFØRINGSAKSEL GELENKWELLE		PTO SHAFT
4.	1501-0010	1	BESKYTTELSESRØR UDV. 1000 MM SCHUTZROHR AUSSEN, 1000 MM		PROTECTION TUBE, OUTER 1000 MM
5.	1501-0009	1	BESKYTTELSESRØR, INDV. 1000 MM SCHUTZROHR INNEN, 1000 MM		PROTECTION TUBE INNER, 1000 MM
11.	1340-9135	1	STIFTFRILØB F5/1R-W2400 STIFTFREILAUF F5/1R-W2400		FREE WHEEL F5/1R-W2400
12.	1340-9039	1	FLANGEGAFFEL (6) FLANSCHGABEL (6)		FLANGE FORK (6)
13.	1341-9523	1	LÅSESTIFT SPERRSTIFT		LOCKING PIN
21.	1340-9155	1	SKIVEKOBLING SCHEIBENKUPPLUNG		DISC COUPLING
22.	1341-9188	3	SMØRENIPPEL C 8 SCHMIERNIPPEL C 8		GREASE NIPPLE C 8
23.	1340-9022	1	SPENDEGAFFEL KLEMMGABEL		CLAMP FORK
24.	1251-9007	2	SPENDESTIFT 10-80 SPANNSTIFT 10-80		SPECIAL PIN 10-80
25.	1501-0109	1	PROFILRØR 1 BGA 1200 MM PROFILROHR GR.BGA 1200 MM		PROFILE TUBE SIZE BGA 1200 MM
26.	1501-0108	1	PROFILRØR 2 A 1000 MM PROFILROHR GR.2 A 1000 MM		PROFILE TUBE SIZE 2 A 1000MM
27.	1340-9019	1	GAFFEL GABEL		FORK
28.	1340-9168	2	KRYDS KREUTZGARNITUR		CENTRE CROSS
29.	1340-9475	4	SKIVE SCHEIBE		WASHER
30.	1340-9037	1	GAFFEL, DOBBELT GABEL, DOBBELTER		FORK, DOUBLE
31.	1341-9189	1	SMØRENIPPEL LIGE M6 SCHMIERNIPPEL M6		GREASE NIPPLE M6
51.	1501-0022	1	PLASTIKSKERM Ø165 SCHUTZTRICHTER Ø165		PLASTIC GUARD Ø165
52.	1341-9411	8	SKRUE SCHRAUBE		SCREW
53.	1341-9630	1	FORSTERKNINGSRING STÜTZRING		SUPPORT RING
54.	1341-9618	2	GLIDERING GLEITRING		BEARING RING
55.	1341-9308	1	PLASTIKSKERM SCHUTZTRICHTER		PLASTIC GUARD
56.	1341-9649	1	GLIDERING RING		RING
57.	1341-9305	1	PLASTIKSKERM SCHUTZTRICHTER		PLASTIC GUARD
58.	1341-9641	1	HOLDEKEDE HALTEKETTE		CHAIN
59.	1341-9647	2	KEDE KETTE		CHAIN

Fig. 81

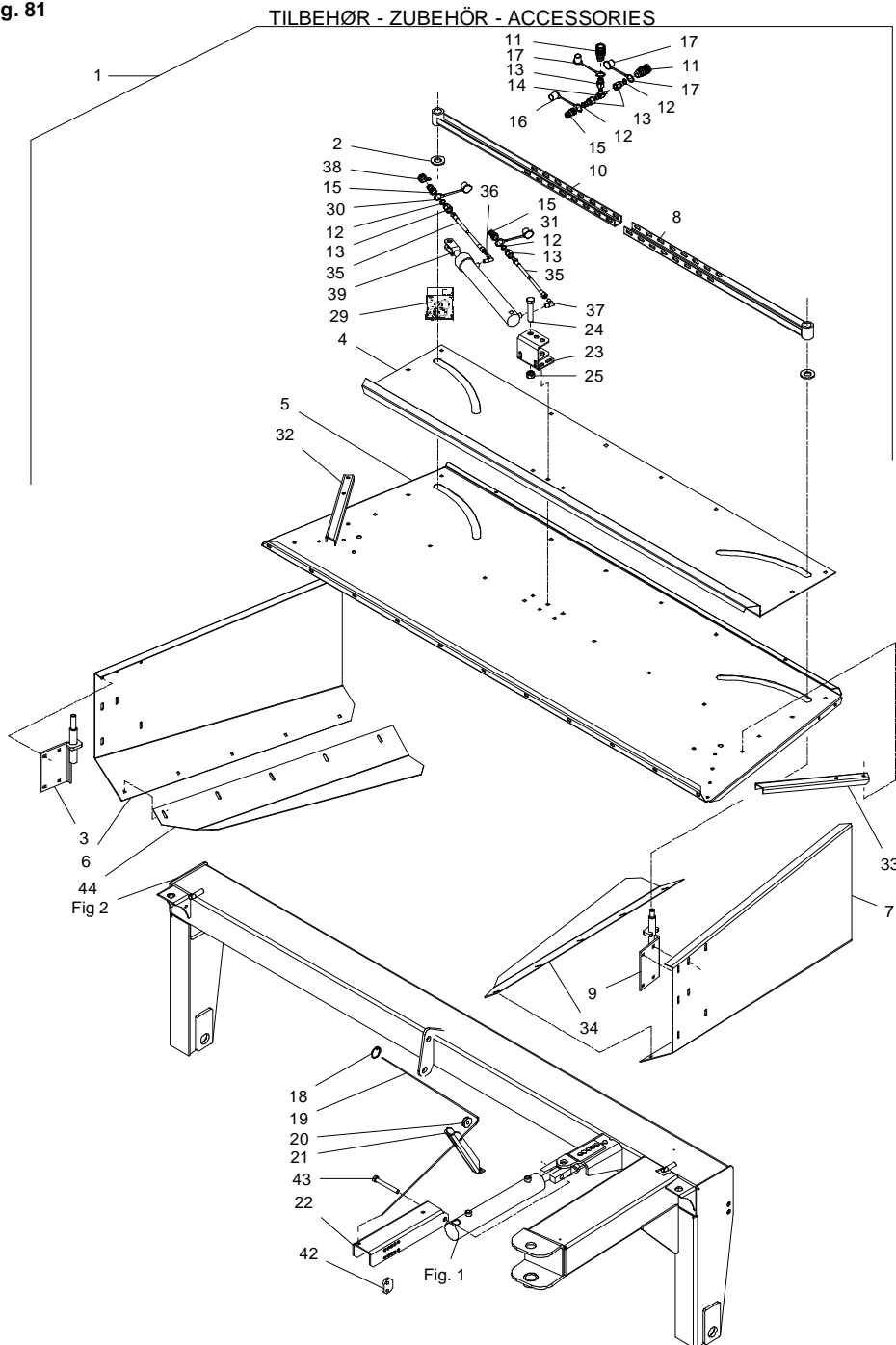

GMS-0020/2 GMS 320 C

FIG. 81.  
TILBEHØR, ZUBEHÖR, ACCESSORIES

>=1230111647

POS.	VARENUMMER	ANTAL	BENEVNELSE	BEZEICHNUNG	DESIGNATION	HERTIL, DAZU, TO THIS, A CECI
1.	4220-1270	1	SKÅRSKERME ASYMETRISK HYDRAUL. SWATH PLATE ASYMETRIC HYDRAUL. SCHWADPLATTE ASYMETRISCH HYDR.			1215-3226 4 1220-3321 4 1220-6321 1 1241-2502 4 1241-5503 1
2.	2228-625X	2	MELLEMLÆG ZWISCHENLAGE		FILLER	
3.	3228-621X	1	TAP ZAPFEN		DOWEL	
4.	2229-981X	1	FORSTERKNING VERSTÄRKERUNG		REINFORCEMENT	1215-3222 12 1220-3321 12 1241-2502 12
5.	2228-720A	1	OVERPLADE OBERPLATTE		TOP PLATE	1215-3222 4 1220-3321 4 1241-2502 4
6.	2083-282X	1	FORLENGER, HØJRE VERLÆNGERUNG, RECHTS		EXTENSION, RIGHT	1215-3226 4 1220-3321 4 1241-2502 4
7.	2083-283X	1	FORLENGER, VENSTRE VERLÆNGERUNG, LINKS		EXTENSION, LEFT	1215-3226 4 1220-3321 4 1220-6321 1 1241-2502 4 1241-5503 1
8.	3228-984X	1	STANG STAB		BAR	1215-3226 4 1220-3321 4 1220-6321 1 1241-2502 4 1241-5503 1
9.	3228-620X	1	TAP ZAPFEN		DOWEL	1215-3226 8 1220-3321 8 1241-2502 8
10.	3228-983X	1	STANG STAB		BAR	1215-3226 4 1220-3321 4 1220-6321 1 1241-2502 4 1241-5503 1
11.	1317-0303	2	LYNKOBLING 1/2" SCHNELLKUPPLUNG 1/2"		QUICK CLUTCH 1/2"	
12.	1317-0715	5	O-RING O-RING		O-RING	
13.	1311-2601	5	NIPPELMUFFE NIPPEL		BUSHING	
14.	1311-8580	2	T-NIPPEL T-NIPPEL		T-NIPPLE	
15.	1317-0302	3	STIK F/LYNKOBLING ANSCHLUSS F/SCHNELLKUPPLUNG		CONNECTION F/QUICK-COUPLING	
16.	1393-0138	1	BESKYTTELSESHETTE GUL SCHUTZKAPPE GELB		PROTECTION CAP YELLOW	
17.	1393-0141	2	BESKYTTELSESPROP SCHUTZVERSCHLUSS		PROTECTING PLUG	
18.	1433-0294	2	LÅSEFJEDER SPERRFEDER		RETAINING SPRING	
19.	1399-0124	6	SNOR 1M SCHNUR 1M		STRING 1M	
20.	2228-735X	1	RULLE ROLLE		ROLLER	1214-4228 1 1220-4321 1
21.	2228-709X	2	KONSOL KONSOLE		BRACKET	

Fig. 81

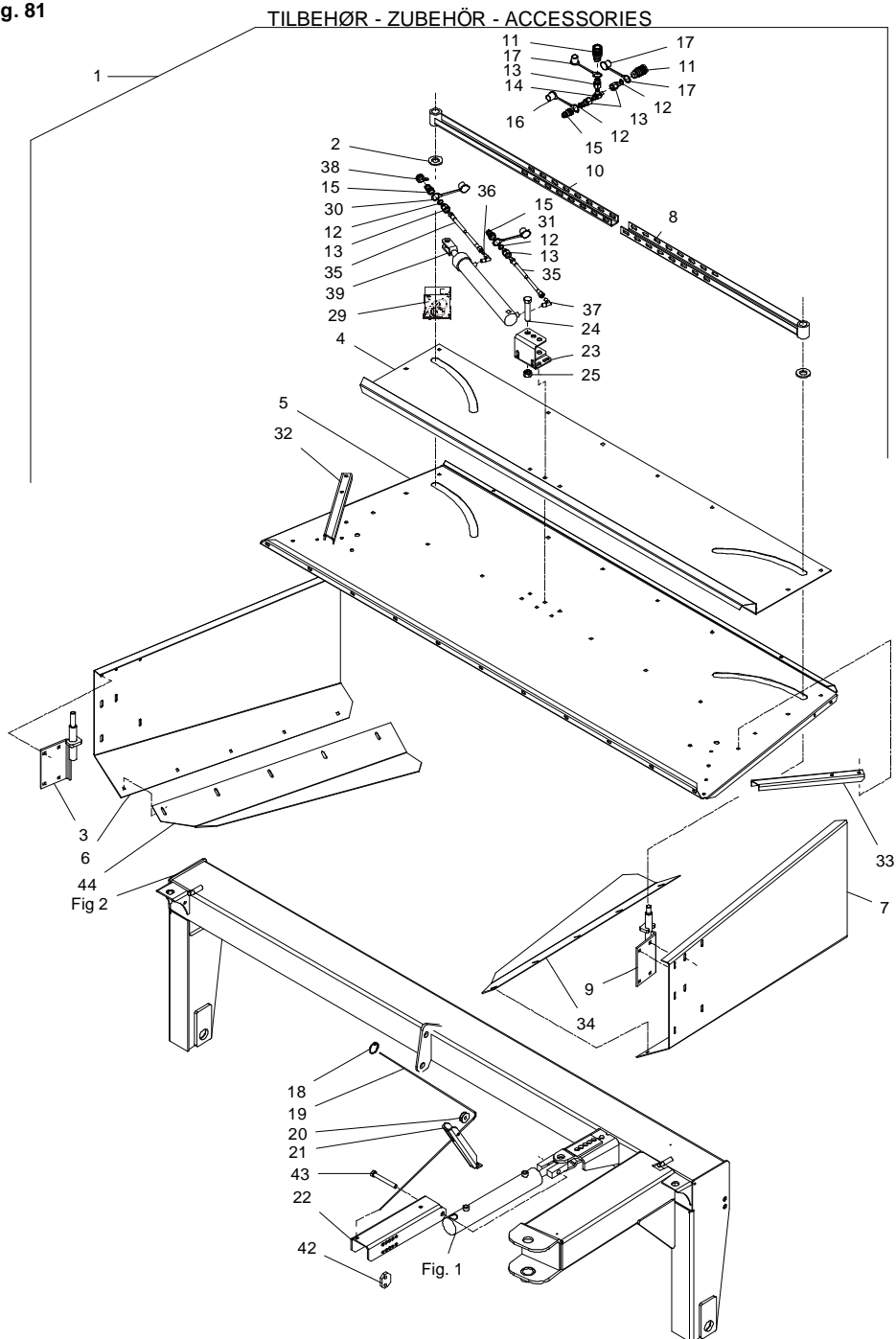

GMS-0020/2 GMS 320 C

FIG. 81.  
TILBEHØR, ZUBEHÖR, ACCESSORIES

>=1230111647

POS.	VARENUMMER	ANTAL	BENEVNELSE	BEZEICHNUNG	DESIGNATION	HERTIL, DAZU, TO THIS, A CECI
22.	2228-707X	1	STOP STOPP		STOP	1214-5430 1 1220-5321 1
23.	3228-630X	1	KONSOL KONSOLE		BRACKET	
24.	1214-6422	1	STÅLSKRUE M20-100 STHALSECHSKANTSCHRAUBE M20-100		STEEL SCREW M20-100	
25.	1220-6321	1	NYLOC MØTRIK M20 NYLOC MUTTER M20		NYLOC NUT M20	
29.	1317-9805	1	PAKNINGSSÆT DICHTUNGSSATZ		SET OF GASKETS	
30.	1393-0139	1	BESKYTTELSESHETTE RØD SCHUTZKAPPE ROT		PROTECTION CAP RED	
31.	1393-0140	1	BESKYTTELSESHETTE BLÅ SCHUTZKAPPE BLAU		PROTECTION CAP BLUE	
32.	2083-958X	1	FORSTÆRKNING VERSTÄRKERUNG		REINFORCEMENT	
33.	2083-964X	1	FORSTÆRKNING VERSTÄRKERUNG		REINFORCEMENT	
34.	2228-998X	1	FORLENGER, VENSTRE VERLÄNGERUNG, LINKE		EXTENSIONER, LEFT	1215-3226 4 1220-3321 4 1241-2402 4
35.	1317-0482	2	HYDRAULIKSLANGE L=8400 HYDRAULISCHER SCHLAUCH L=8400		HYDRAULIC TUBE L=8400	
36.	2307-111X	1	DYSE DUESE		NOZZLE	
37.	1311-8401	2	VINKELFORSKRUNING WINKELVERSCHRÄUBUNG		ANGLE COUPLING	
38.	1311-8587	1	SLANGEHOLDER KLEMMBUEGEL		CLAMPING HOOP	
39.	2228-716X	1	CYLINDER ZYLINDER		CYLINDER	
42.	2228-708X	2	STOPKLODS PRELLKLOTZ		STOP BLOCK	1215-4322 4 1220-4321 4
43.	1214-5430	1	STÅLSKRUE M16-130 STHALSECHSKANTSCHR. M16-30		STEEL SCHREW M16-130	
44.	2228-999X	1	FORLENGER, HØJRE VERLÄNGERUNG, RECHTE		EXTENSIONER, RIGHT	1215-3226 4 1220-3321 4 1241-2402 4

Fig. 82

TILBEHØR - ZUBEHÖR - ACCESSORIES

GMS-0020/2 GMS 320 C

FIG. 82.  
TILBEHØR, ZUBEHÖR, ACCESSORIES

>=1230111647

HERTIL, DAZU,  
TO THIS, A CECI

POS.	VARENUMMER	ANTAL	BENÆVNELSE	BEZEICHNUNG	DESIGNATION		
1.	4220-1316	1	FORLENGER FOR AFSKÆRMNING VERLÆNGER F/SCHUTZVORRICHTUNG		EXTENSIONER FOR SCHIELD		
2.	2228-246X	2	BÆRING TRÄGER		CARRIER		
3.	2228-268X	1	FORLENGER VERLÆNGERUNG		EXTENSION		

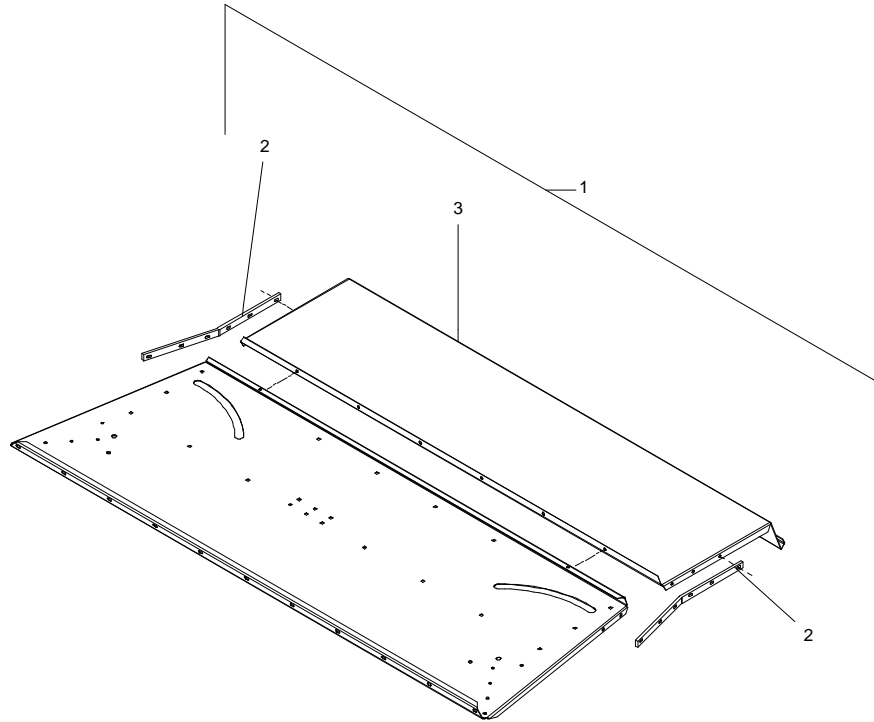
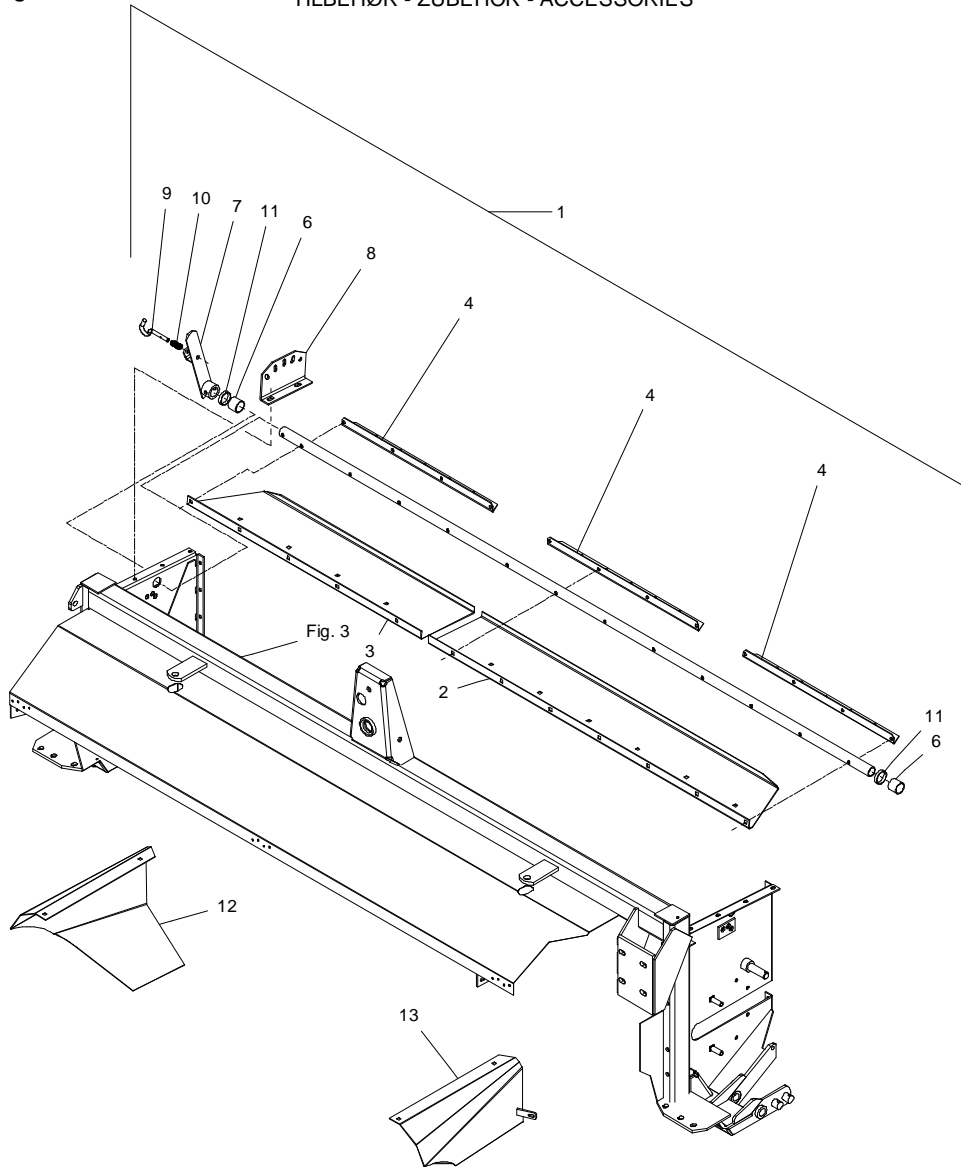

Fig. 83

TILBEHØR - ZUBEHÖR - ACCESSORIES



GMS-0020/2 GMS 320 C

FIG. 83.  
TILBEHØR, ZUBEHÖR, ACCESSORIES

>=1230111647

POS.	VARENUMMER	ANTAL	BENEVNELSE	BEZEICHNUNG	DESIGNATION	HERTIL, DAZU, TO THIS, A CECI	
1.	4220-1265	1	UDSTYR FOR BREDT SKÅR AUSRUESTUNG FUER BREITSTREUEN		EQUIPMENT FOR WIDE SPREADING		
2.	2086-484X	1	STOPPLADE STOPSCHUTZ		STOP PLATE	1214-3224 1220-3321 1241-2502	7 7 7
3.	2086-179X	1	STOPPLADE, HØJRE SPERRBLECH		STOP GUARD	1214-3224 1220-3321 1241-2502	5 5 5
4.	2086-936X	3	SPÆNDESTYKKE SPANNSTUECK		CLAMP	1215-3222 1220-3321 1241-2502	4 4 4
5.	2086-180X	1	RØR ROHR		TUBE		
6.	2086-943X	2	AFSTANDSRØR DISTANCEROHR		SPACER		
7.	3086-934X	1	HÅNDTAG HANDGRIFF		HANDLE	1251-5401 1251-7401	1 1
8.	2086-935X	1	INDSTILLINGSKONSOL EINSTELLUNGSKONSOLE		ADJUSTMENT BRACKET	1213-3324 1220-3321 1241-2502	2 2 2
9.	2086-829X	1	STYRETAP STEUERUNG SZAPFEN		GUIDE DOWEL	1241-2202 1251-2104	1 1
10.	1431-2195	1	TRYKFJEDER DRUCKFEDER		COMPRESSION SPRING		
11.	2087-671X	2	AFSTANDSRØR DISTANZROHR		DISTANCE TUBE		
12.	3086-561X	1	SKÅRPLADE, INDV. HØJRE SCHWADPLATTE, INNERE RECHTE		SWATH PLATE, INNER RIGHT	1215-3226 1215-3228 1220-3321 1241-2502	1 2 3 3
13.	3086-562X	1	SKÅRPLADE, INDV. VENSTRE SCHWADPLATTE, INNERE LINKE		SWATH PLATE, INNER LEFT	1215-3226 1215-3228 1220-3321 1241-2502	1 2 3 3



Fig. 84

TILBEHØR - ZUBEHÖR - ACCESSORIES

GMS-0020/2 GMS 320 C

FIG. 84.  
TILBEHØR, ZUBEHÖR, ACCESSORIES

>=1230111647

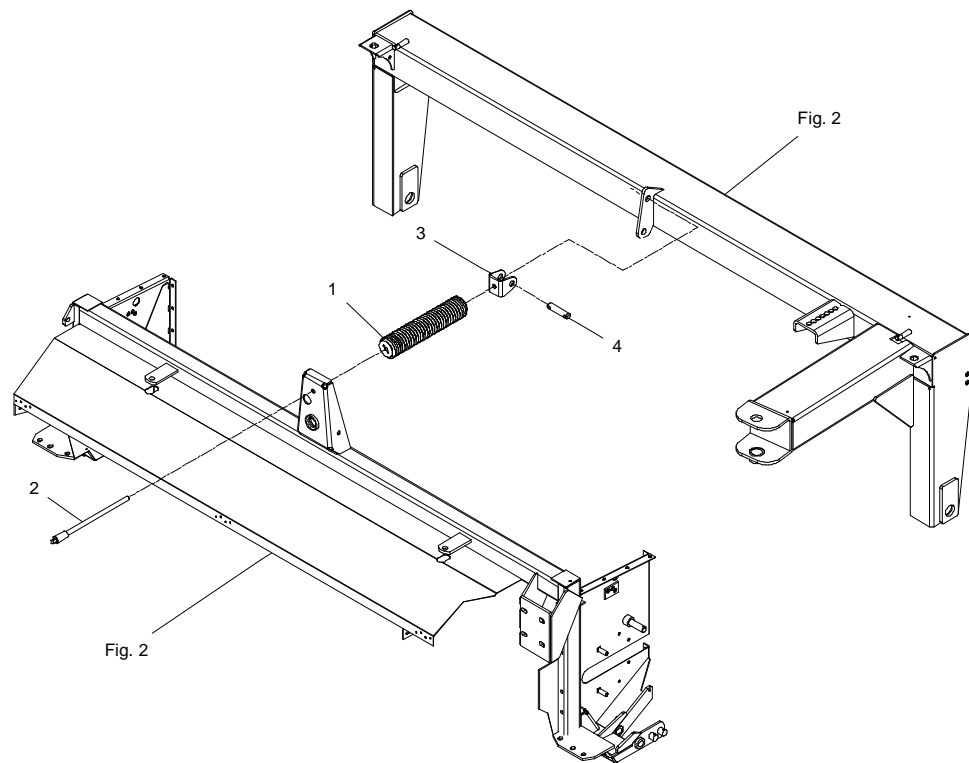

POS.	VARENUMMER	ANTAL	BENØVNELSE	BEZEICHNUNG	DESIGNATION	HERTIL, DAZU, TO THIS, A CECI	
1.	3089-314X	1	FJEDER FEDER		SPRING		
2.	3210-346X	1	SPINDEL SPINDEL		SPINDLE	1220-5122	1
3.	2213-041X	1	FJEDERKONSOL FEDER KONSOLE		SPRING BRACKET	1213-5422 1241-4502	1 1
4.	2213-043X	1	TAP ZAPPEN		DOWEL	1251-7301	2



Valid from: | Gültig ab:  
Valable à partir de: | Gyldig fra:  
**17. 04. 2012**

Serial No.: | Maschinen Nr.:  
No. de serie: | Fabrikationsnr.:  
**2130111647**