

Serie 10.1

ELHO

TUBE 2020 AC/ACI

List of spare parts

OY **ELHO** AB
FIN-68910 BENNÄS
FINLAND

TUBE 2020 spare parts**Fig 1**

Pos	Name	No	Pcs.
1	Roller $\phi=90$ mm	845310	1
2	Long roller	845150	15
3	Rolltable frame, pivoting	845230	1
4	Lower bearing half for rollers	845300	2
5	Shaft for support roller	845550	4
	Shaft for support roller for square bales	845810	4
6	Endsupport roller	803580	4
	Bearing 6007 2RS	848000	8
7	Cylinderpin long for tablecylinder	845770	2
8	Cylinder (table)	805390	2
9	Cylinderpin short for tablecylinder	845781	2
10	Rolltable frame, non pivoting	845090	1
11	Tube spacer	845080	34
12	Upper bearing for rollers L=900	845294	2
13	Slide bearing 25/28 L=15	848002	4
14	Short roller	845060	2
15	Tube spacer	845080	4
16	Upper roller support	845011	2
17	Bale guide	845630	2
18	Wheel compl. 14.0/65-16	468019	4
19	Shaft for bale guide	845760	4
20	Side plate right	841251	1
	Side plate left	841252	1
21	Frame	841001	1
22	Pin	845750	2
23	Handle	845730	2
24	Limiter righth	845701	2
	Limiter left	845711	2
25	Tooth segment	845651	4
26	Spacer bloc	845660	4
28	Teleskope tube inner	844336	1
29	Teleskope tube outh	844330	1
30	Pin	451207	1
31	Screw M8x12 DIN 914	131285	1
32	Wheel	845055	1
33	Protection plate	840590	1
34	Sensor bracket	807100	1
35	Screw M6x35 DIN 933	130680	2
36	Sensor	844800	1
37	Long roller	845155	1
38	Upper bearing for rollers L=370	845292	2

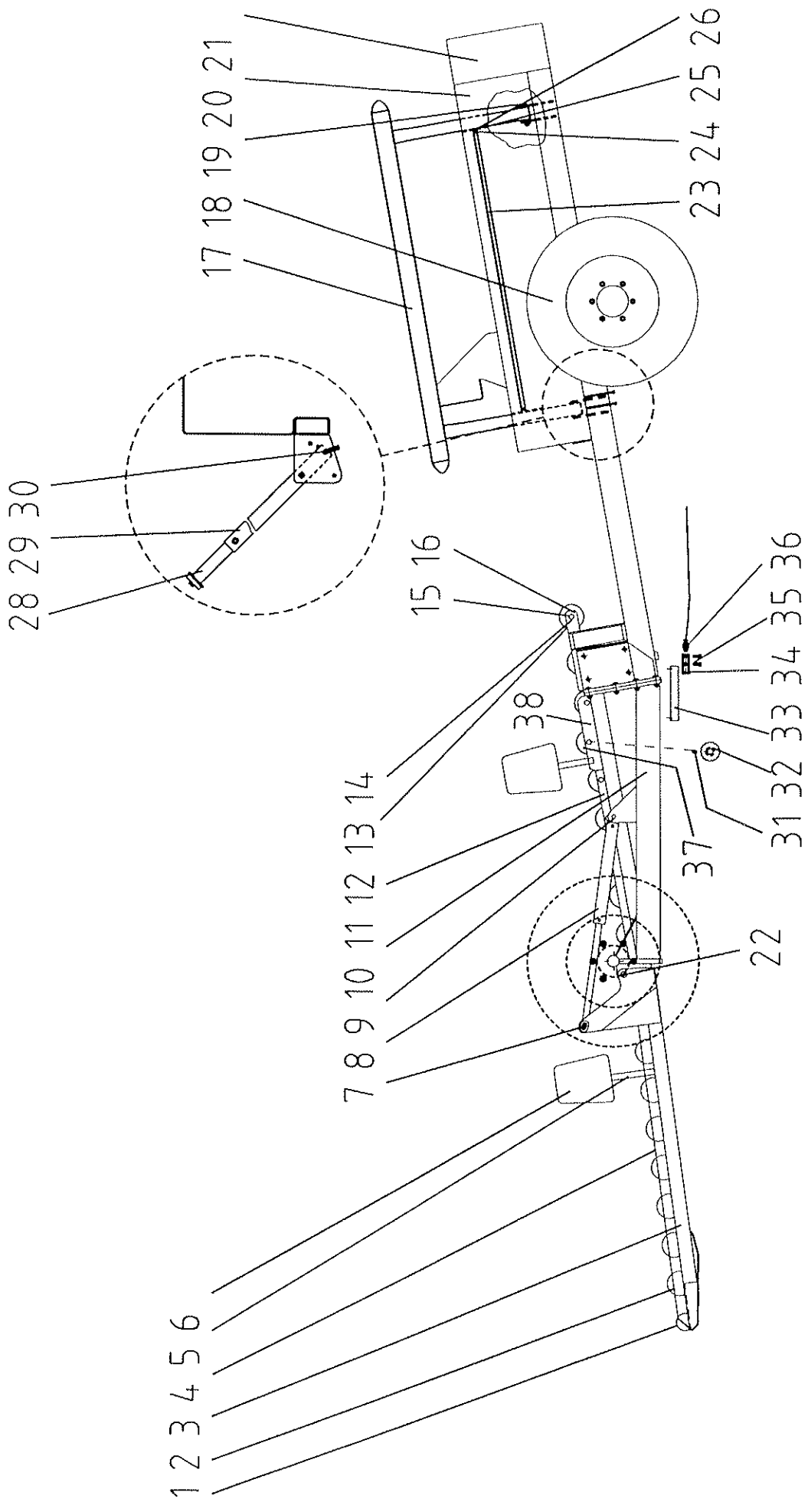

Fig 1

Fig 2			
Pos	Name	No	Pcs.
1	Support shaft	807815	1
2	Beacon compl	807862	1
3	Tensioner ring	843000	1
4	Guard right	846001	1
	Guard left	846002	1
5	Support tube	843555	2
6	Spacer L=52	843610	2
7	Ball bearing 6306 2RS	848008	4
8	Guide wheel	843560	2
9	Washer M30 DIN 125A+låsring A30 DIN471		2
10	Guide wheel shaft right	843605	1
	Guide wheel shaft left	843600	1
11	Wheel hub compl. FAD	848004	3
	Wheel hub compl Nagböl HDL 50-6	848006	3
12	Support spike	845530	2
13	Ring pin	846270	2
14	Steering cylinder	842065	1
15	Steering cylinder shaft	842085	1
16	Wheel axle compl. with hubs	842003	1
17	Brake handle	842135	1
18	Spring 5x25x120	848010	1
19	Arm	848012	1
20	Distance tube	841380	1
21	Pin	845750	2
22	Transport triangle	845431	1
23	Pin for transport triangle	845790	1
24	Push bar	845451	1
25	Pin for transport triangle	845790	1
26	Pin for squar beam	845441	1
27	Square beam	845435	1
28	Guard	846311	2
29	Guard bracket	846330	4
30	U-bolt	843690	4
31	End plate	840440	1
32	Pusher tube inner	840420	1
33	Pusher tube outhr	840400	1
34	Pin for pusher tube	840480	3
35	Extension	840521	1

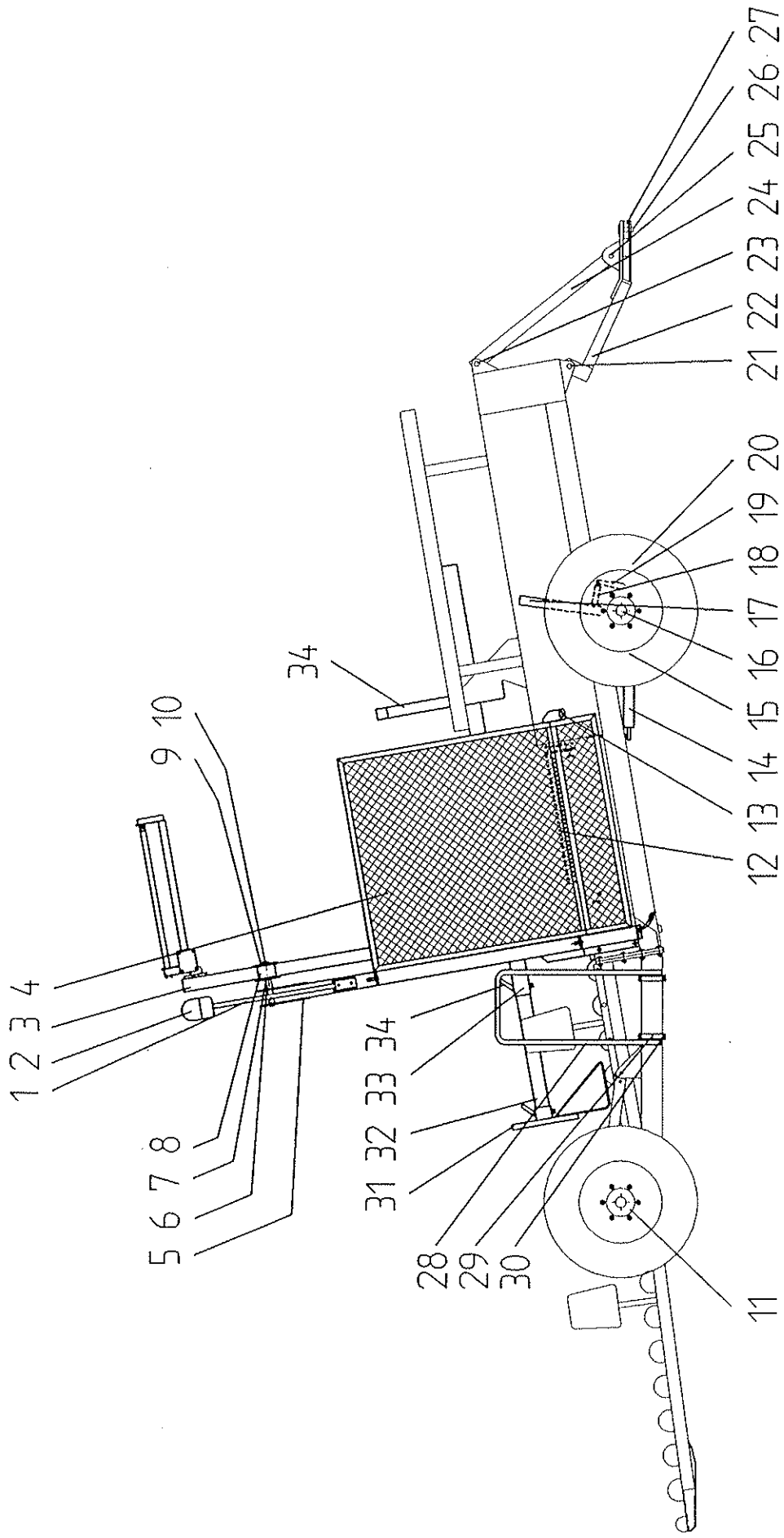

Fig 2

Fig 3								
Pos	Name	No	Pcs.					
1	Pre stretcher frame	843102	2					
2	Cup	843920	2					
3	Gear z=34	808170	2					
4	Bearing flange	843880	8					
5	Gear z=57	808180	2					
6	Ball bearing 6202 2RS	808021	12					
7	O-ring 34,6x2,62	808022	24					
8	Brake	802011	2					
9	Torsion spring rear	843280	2					
	Torsion spring front	843290	2					
10	Shaft for brake roll support	843260	2					
11	Spacer tube	843190	2					
12	Roller support hub	802181	4					
13	Ball bearing 6206 2RS	808342	4					
14	Arm for brake roller	843255	2					
15	Brake roller complett	843200	2					
16	Brake roller arm with brake support	843250	2					
17	Wing nut	843270	2					
18	Rubber roller	808130	4					
19	Steel roller	843930	2					
20	Sensor roller for film	843800	2					
21	Ball bearing 6/13x5 ZZ, stainless	848014	4					
22	Pendel shaft	843821	2					
23	Magnet	807090	2					
24	Limiter	843900	2					
25	Counter weight	843861	2					
26	Sensor arm	843851	2					
27	Bearing house	843811	2					
	Spacer 7/10 L=20	843813	2					
28	Ball bearing 6/13x5 ZZ, stainless	848014	4					
29	Spring 0,8x8,20x60	848016	2					
30	Spring mounting	843910	2					

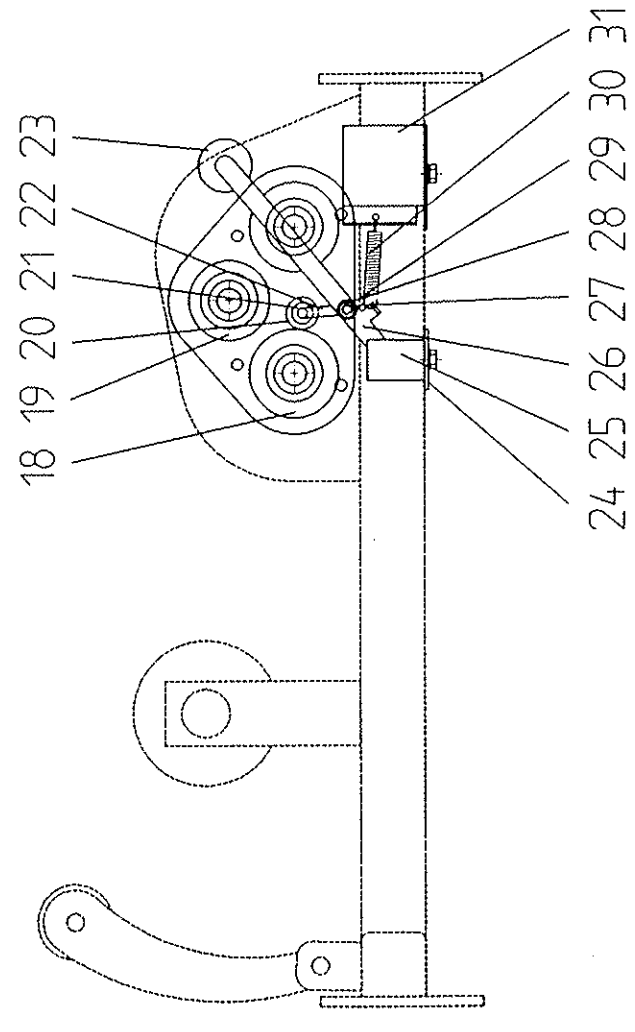
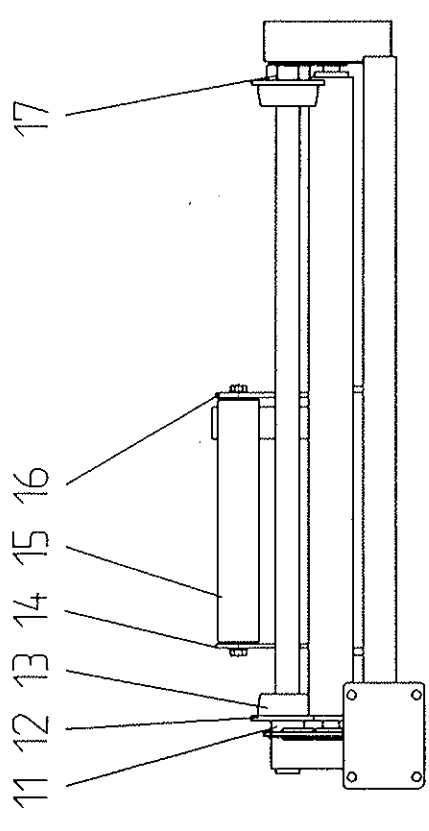
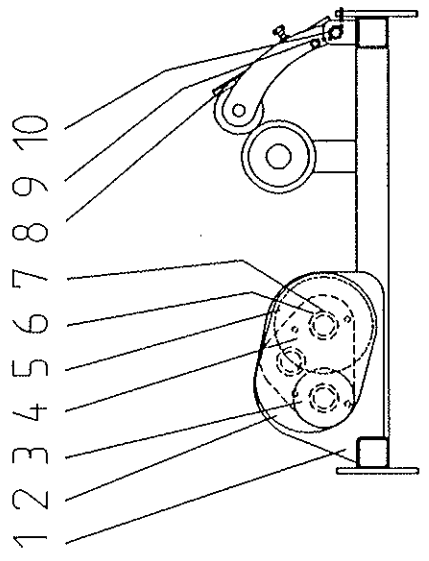

Fig 3

Fig 4							
Pos	Name	No	Pcs.				
1	Sprocket 5/8" z=38	843400	2				
	Key 8x7 L=50	848040	2				
2	Ball bearing 6006 2RS	848018	4				
3	Spacer L=5	843430	2				
4	Axle with hub	843500	2				
5	Drive wheel (wearing surface)	843451	2				
6	Hub for drive wheel	843470	2				
7	Roller chain 10B (5/8"), long	848020	1				
	Joint 10B	801240	2				
8	Tensioner block	400580	2				
9	Chain guard, left	846260	1				
10	Roller chain 10B,(5/8"), short	848022	1				
11	Chain guard, righth	846220	1				
12	Sprocket for motor, 5/8" z=2x24	801094	1				
13	Hydraulmotor for ring OMP 50	848024	1				
14	U.bolt	843690	2				
15	Scraper, short	843700	1				
	Scraper, long	843710	1				
16	Support for film sensor	843890	1				

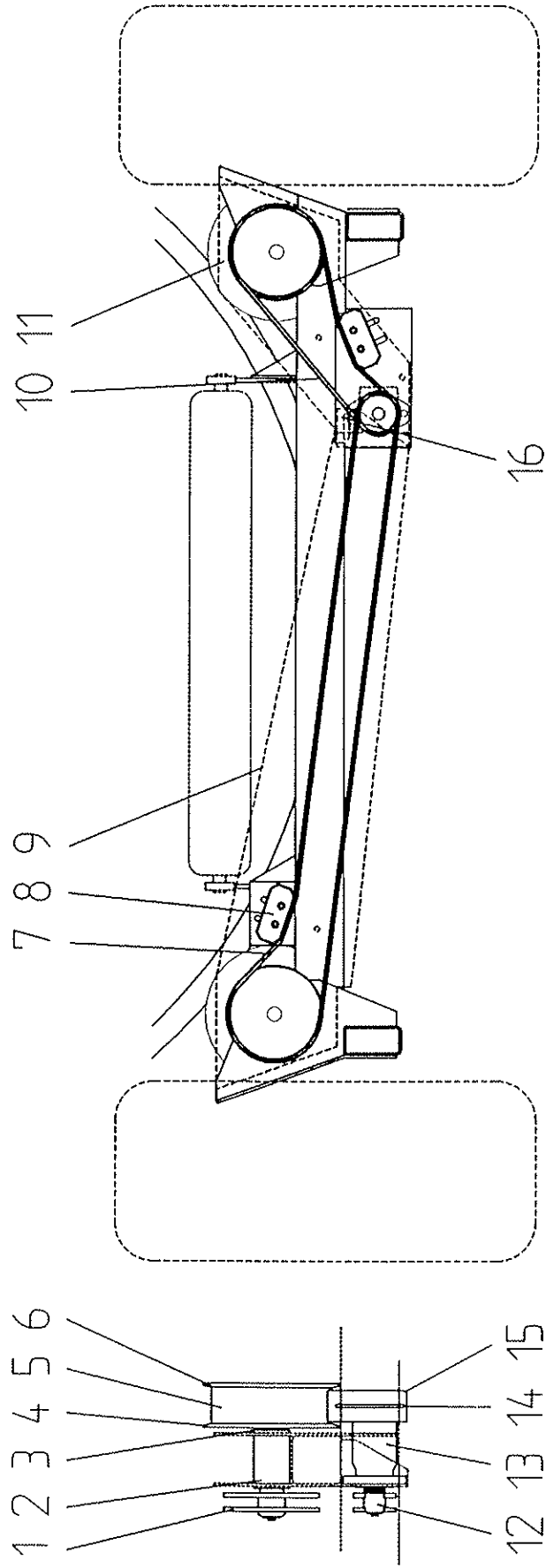

FIG 4

Fig 5			
Pos	Name	No	Pcs.
1	Sprocket for feed shaft 1" z=44	840160	1
2	Roller chain 16B (1")	848027	1
	Joint 16B (1")	848028	1
3	Feed shaft	840350	1
4	Feed sprocket	840300	2
5	Tensioner block	400580	2
6	Roller chain 12B (3/4")	848030	1
	Joint 12B (3/4")	508046	1
7	Intermediate shaft	840230	1
8	Intermediate sprocket 1" z=13+3/4"z=46	840190	1
9	Tensioner block	400580	1
10	Kohlswa chain link with bracket	840570	12
11	Kohlswa 78 chain link	856508	96
12	Pusher	840012	1
13	Idler wheel	840340	2
14	Nut for tensioner screw	840390	2
15	Idler wheel shaft	840370	1
16	Slide bearing 35/39 L=20	528049	4
17	Tube spacer	840380	1
18	Tensioner screw	840395	2
19	Hydraul motor OMR 160 LL	801028	1
	Seal kit for OMR 160LL	801029	1
20	Roller shaft	840070	4
21	Washer M24 DIN 125A		8
22	Ball bearing 6205 2RS	518312	8
23	Roller	840060	4
24	Bearing UCF 207	528045	2
25	Motor sprocket 3/4" z=13	840260	1
26	Key 8x7 L=30	848032	2
27	Spacer L=14	840250	1
26	Key 14x9 L=65	848034	1
29	Spacer L=38	840240	1
30	Bearing house for feed shaft	840150	2
31	Slide bearing SKF GLY.PG 505520	848038	4
32	Square beam	840081	1
33	Key 14x9 L=100	848036	2

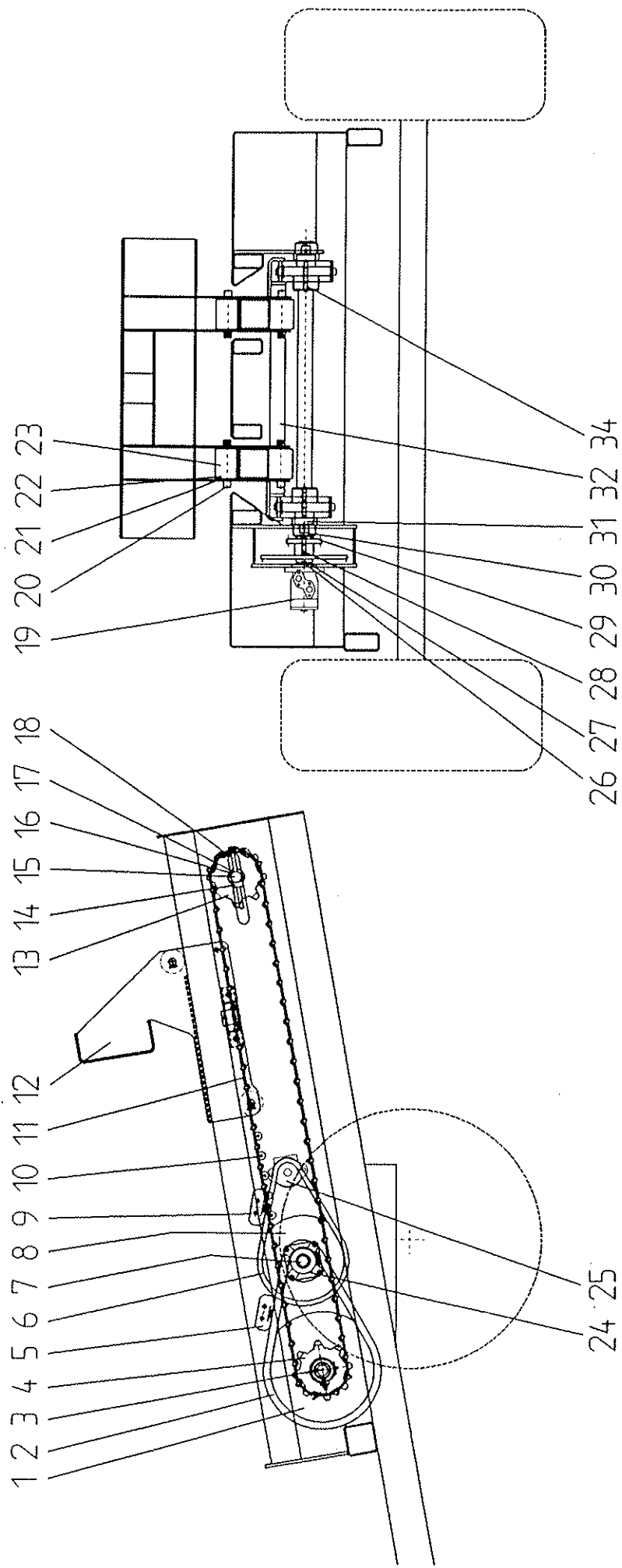

FIG 5

Fig 6							
Pos	Name	No	Pcs.				
1	Cylinder (table)	805390	2				
2	Tap BHK-04	518120	2				
3	Steering cylinder	842065	3				
4	Pressure switch (NO) PMM50A	848050	1				
5	Hydraulic motor OMR 160LL	801028	1				
	Seal kit for OMR 160LL	801029	1				
6	Speed valve VFRC 3-L 1/2"	868040	1				
7	Hydraulic motor OMP 50	848024	1				
8	Non return valve 1/2"	848052	1				
9	Pressure limiter EMVSDI20 (150/30bar)	848054	1				
10	Base plate PL06-R6-2S	848054	1				
11	Valve MD1D-S4 12VDC	848056	3				
12	Pressure limiter EMVSC30 (150bar)	848058	2				
13	Base plate PL06-R6-SL	848060	1				
14	Return filter OMTF 75 compl.	848062	1				
	Filter cartridge for 848062	848064	1				
15	Filler cup TR-2, compl	848066	1				
16	Plug 1/2"	848068	1				
17	Oil glas LG2T	848070	1				
18	Retur hose (tank)	848072	1				
19	Mounting for suction hose, tank	848074	2				
20	Tank	844201	1				
21	Mounting for suction hose, pump	848076	2				
22	Hydraulic pump (double), compl.	848078	1				

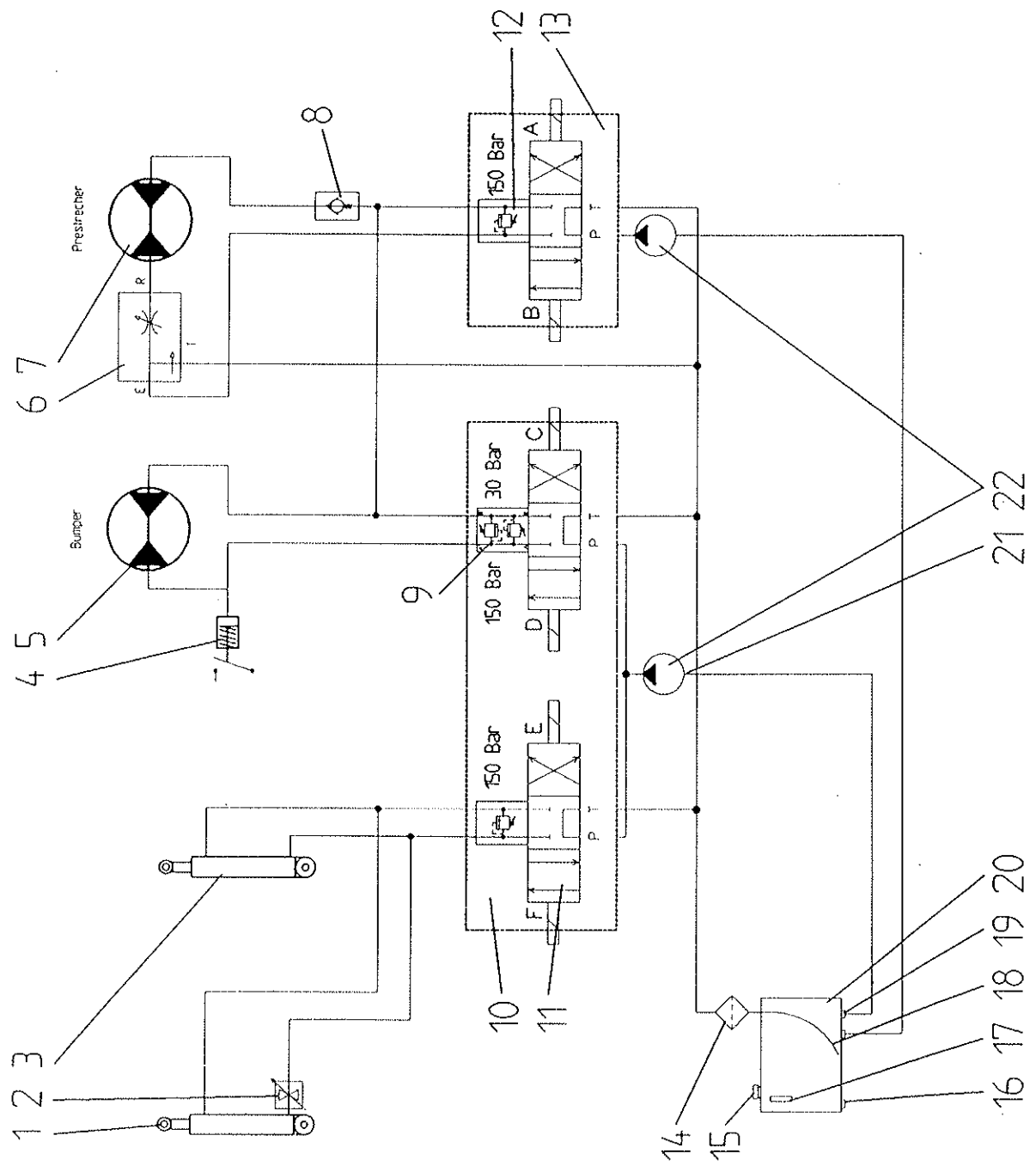

Fig 6

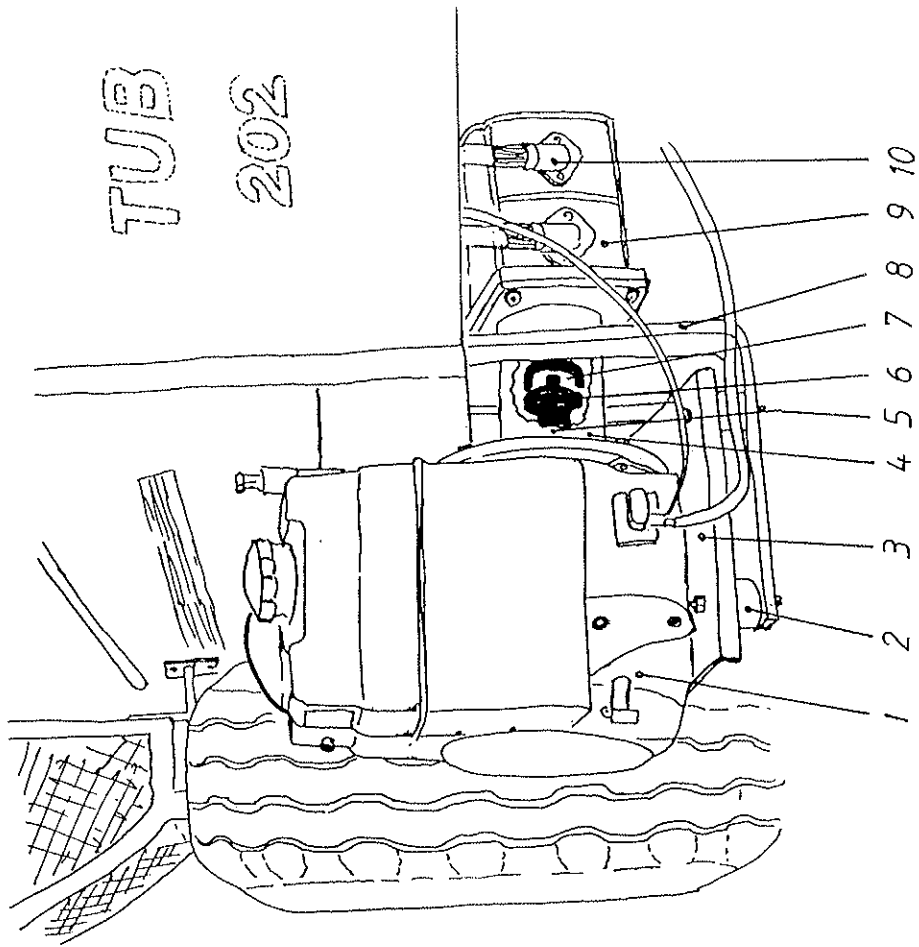

Fig 7

Fig 8

Pos	Name	No	Pcs.	D	D1	D2	D3	L
D	Hose 1/4"	844010	1	1/4"	1/4"	1/4"		550
C	Hose 1/4"	844020	1	1/4"	1/4"	1/4"		1000
D	Hose 1/4"	844030	1	1/4"	1/4"	1/4"		2300
C	Hose 1/4"	844040	1	1/4"	1/4"	1/4"		2750
G	Hose 1/4"	844050	2	1/4"	1/2"	1/4"	1/4"	3900
E	Hose 3/8"	844060	2	3/8"	1/2"	3/8"		3750
H	Hose 1/4"	844080	2	1/4"	1/8"	1/8"		300
D	Hose 1/2"	844410	1	1/2"	1/2"	1/2"		3200
D	Hose 3/8"	844420	1	3/8"	3/8"	1/2"		270
D	Hose 3/8"	844431	2	3/8"	3/8"	3/8"		750
A	Hose 3/8"	844441	1	1/2"	3/8"			950
B	Hose 3/8"	844450	1	3/8"	1/2"	3/8"		500
D	Hose 3/8"	844460	6	3/8"	3/8"	3/8"		500
A	Hose 3/8"	844470	1	3/8"	1/2"	3/8"		700
A	Hose 3/8"	844481	1	3/8"	1/2"	3/8"		1150
I	Suction hose 1"	844490	2	1"				~2500
D	Hose 1/4"	844520	2	1/4"	1/4"	1/4"		3650

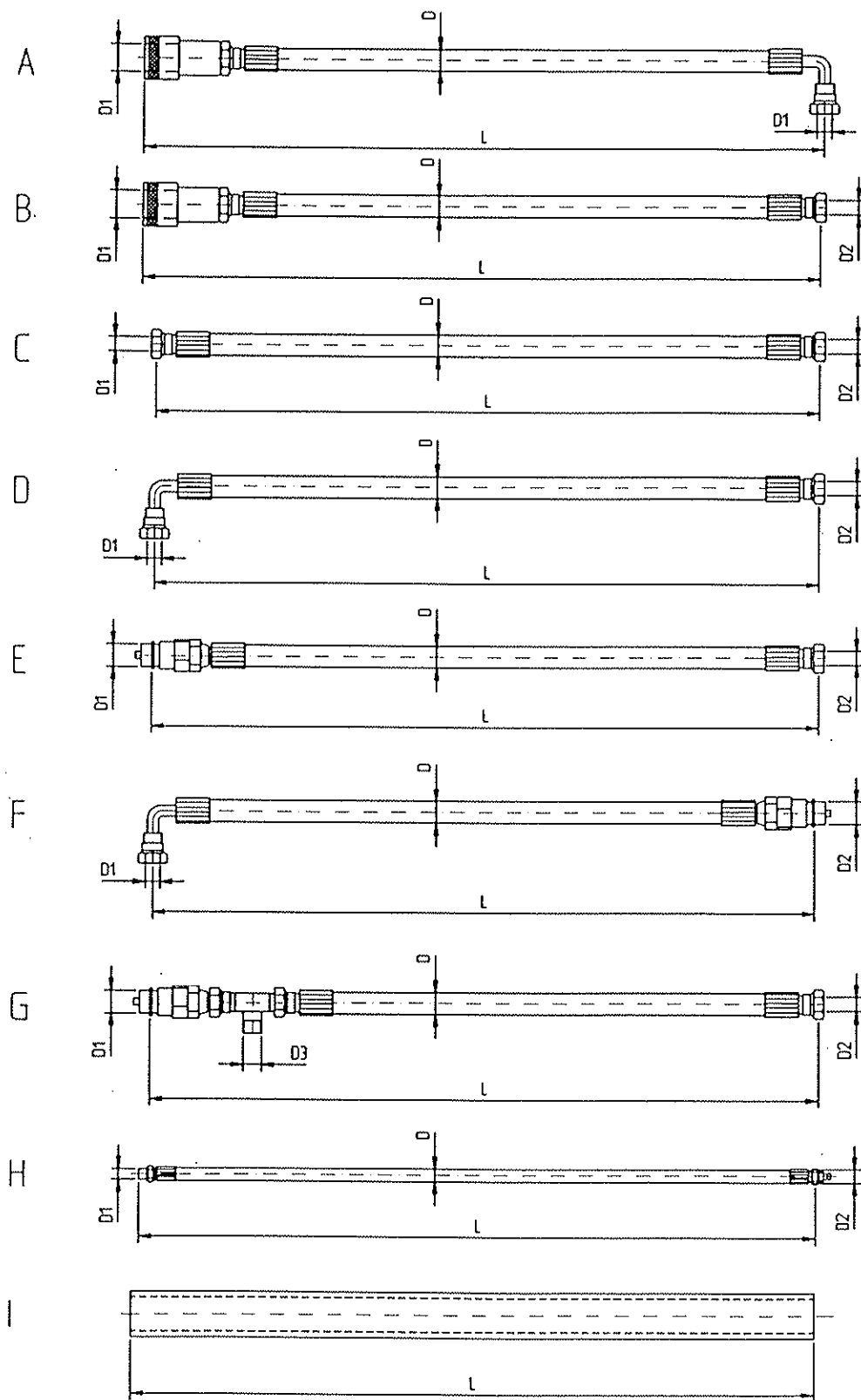

Fig 8

Fig 9									
Pos	Name	No	Pcs.						
1	Feed sensor mounting, front (A)	844710	1						
	Feed sensor mounting, rear (C)	844730	1						
	Feed sensor mounting, delay (B)	844750	1						
2	Magnet sensor RDS	807080	4						
3	Magnet RDS	807090	4						
4	Cable serie compl with connection box	844575	1						
5	Fuse 20A	848092	1						
6	Relay Takamisawa LZ-12H	848094	1						
7	Battery cable (earth)	848102	1						
8	Battery 12V60Ah	848096	1						
9	Battery support	847000	1						
10	Battery mounting	847080	1						
11	Battery cable (positive) L=600	848098	1						
12	Main switch	848106	1						
13	Fuse 6,3 A (L=20)	807876	8						
14	Control box RDS 2020 AC/ACI	848108	1						
15	Bracket for above	807814	1						
16	Cable, control box-connection box	807886	1						
17	Mounting for infra receiver	807818	1						
18	Infra receiver	807866	1						
19	Earth cable for motor L=200	848104	1						
20	Infra transmitter	807867	1						
21	Cable, motor-main switch	848100	1						
		848110	1						

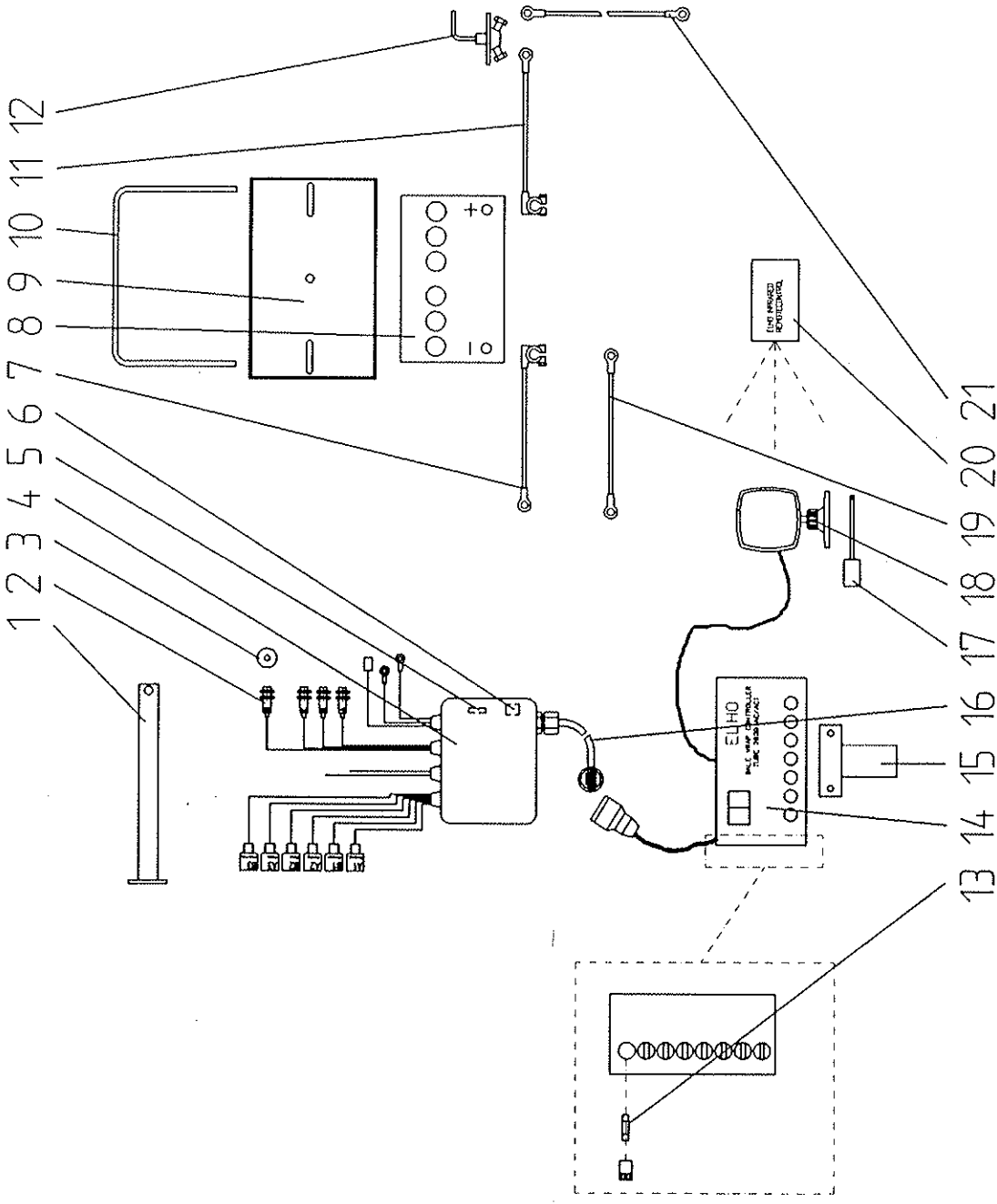

Fig 9